

# County of Monterey

Cayenne Room  
1441 Schilling Place  
Salinas Ca. 93901



## Meeting Agenda - Final-Revised

**ADDENDUM SUPPLEMENTAL - FORMATTING CORRECTIONS**

**Monday, March 18, 2024**

**8:30 AM**

**SPECIAL MEETING**

### **Water Resources Agency Board of Directors**

*Mike LeBarre, Chair*

*Matt Simis, Vice Chair*

*Mark Gonzalez*

*Deidre Sullivan*

*Ken Ekelund*

*Mike Scattini*

*Jason Smith*

*John Baillie*

*Jon Conatser*

**Participation in meetings:**

You may attend the Board of Directors meeting through the following methods:

1. You may attend in person

2. Attend via Zoom (info below) or observe the live stream of the Board of Directors meetings at [http://monterey.granicus.com/ViewPublisher.php?view\\_id=19](http://monterey.granicus.com/ViewPublisher.php?view_id=19) or <http://www.mgtvonline.com/>

3. For ZOOM participation please join by computer audio at:  
<https://montereycty.zoom.us/j/99769079850>

OR to participate by phone call any of these numbers below:

+1 669 900 6833 US (San Jose)

+1 346 248 7799 US (Houston)

+1 312 626 6799 US (Chicago)

+1 929 205 6099 US (New York)

+1 253 215 8782 US

+1 301 715 8592 US

Enter this Meeting ID number: 997 6907 9850 when prompted. Please note there is no Participant Code, you will just press # again after the recording prompts you.

You will be placed in the meeting as an attendee; when you are ready to make a public comment if joined by computer audio please Raise your Hand; and by phone please push \*9 on your keypad.

**PLEASE NOTE: IF ALL BOARD MEMBERS ARE PRESENT IN PERSON, PUBLIC PARTICIPATION BY ZOOM IS FOR CONVENIENCE ONLY AND IS NOT REQUIRED BY LAW. IF THE ZOOM FEED IS LOST FOR ANY REASON, THE BOARD OF DIRECTORS MEETING MAY BE PAUSED WHILE A FIX IS ATTEMPTED BUT THE MEETING MAY CONTINUE AT THE DISCRETION OF THE CHAIRPERSON.**

4. If you choose not to attend the Board of Directors meeting but wish to make a comment on a specific agenda item, please submit your comment via email by 5:00 p.m. on the Friday before the meeting.. Please submit your comment to the Secretary of the Board at [WRAPubliccomment@co.monterey.ca.us](mailto:WRAPubliccomment@co.monterey.ca.us) In an effort to assist the Secretary in identifying the agenda item relating to your public comment please indicate in the Subject Line, the meeting body (i.e. Board of Directors Agenda) and item number (i.e. Item No. 10). Your comment will be placed into the record at the Board meeting.

**Participacion en Reuniones:**

Puede asistir a la reunion de la Junta Directiva a traves de los siguientes metodos:

---

1. Podar asistir personalmente a la reunion; o,
2. Asistir por Zoom (informacion a continuacion), que observe la transmisión de la reunión de la Junta Directiva en vivo por [http://monterey.granicus.com/ViewPublisher.php?view\\_id=19](http://monterey.granicus.com/ViewPublisher.php?view_id=19) o <http://www.mgtvonline.com/>
3. Para participar for ZOOM, por favor únase for audio de computadora por:  
[https://montereycty.zoom.us/j/997\\_6907\\_9850](https://montereycty.zoom.us/j/997_6907_9850)

O para participar for teléfono, llame a cualquiera de los números a continuación:

+1 669 900 6833 US (San Jose)

+1 346 248 7799 US (Houston)

+1 312 626 6799 US (Chicago)

+1 929 205 6099 US (New York)

+1 253 215 8782 US

+1 301 715 8592 US

Cuando se le solicite, ingrese este número de reunión: 997 6907 9850. Por favor tenga en cuenta que no hay código de participante, simplemente presione # nuevamente después de que la grabación se lo indique.

Se le colocará en la reunion como asistente; cuando desee hacer un comentario público si esta unido por la computadora utilice la opción de levantar la mano en el chat de la pantalla; o por teléfono presione \*9 en su teclado.

**TENGA EN CUENTA: SI TODOS LOS MIEMBROS DE LA JUNTA ESTÁN PRESENTES EN PERSONA, LA PARTICIPACIÓN PÚBLICA DE ZOOM ES SOLO POR CONVENIENCIA Y NO ES REQUERIDA POR LA LEY. SI EL FEED DE ZOOM SE PIERDE POR CUALQUIER MOTIVO, LA REUNIÓN DE LA JUNTA DIRECTIVA PUEDE PAUSARSE MIENTRAS SE INTENTA UNA SOLUCIÓN, PERO LA REUNIÓN PUEDE CONTINUAR A DISCRECIÓN DEL PRESIDENTE.**

4. Si prefiere no asistir a la reunión de la Junta Directiva pero desea hacer un comentario sobre algún tema específico de la agenda, por favor envíe su comentario por correo electrónico antes de las 5:00 p.m. el Viernes antes de la reunion.. Envíe su comentario al Secretario de la junta al correo [electronico WRAPubliccomment@co.monterey.ca.us](mailto:WRAPubliccomment@co.monterey.ca.us)  
<mailto:WRAPubliccomment@co.monterey.ca.us> Para ayudar al Secretario a identificar el artículo de la agenda relacionado con su comentario, por favor indique en la linea de asunto del correo electronico el cuerpo de la reunion (es decir, la Agenda de la Junta Directiva) y el número de artículo (es decir, el Artículo No. 10). Su comentario se colocará en el registro de la reunion de esta Junta.

**NOTE: All agenda titles related to numbered agenda items are live web links. Click on the title to be directed to corresponding Board Report.**

**PUBLIC COMMENT: Members of the public may address comments to the Board concerning each agenda item. The timing of public comment shall be at the discretion of the Chair.**

**THE BOARD RECESSES FOR CLOSED SESSION AGENDA ITEMS: Closed Session may be held at the conclusion of the Board's Agenda, or at any other time during the course of the meeting, before or after the scheduled time, announced by the Chairperson of the Board. The public may comment on Closed Session items prior to the Board's recess to Closed Session.**

**Call to Order at 8:30 A.M.**

**Roll Call**

**Public Comments on Closed Session Items**

1. Closed Session under Government Code section 54950, relating to the following items:
  - a. Pursuant to Government Code section 54956.9(d)(2), the Board will confer with legal counsel regarding one matter of significant exposure to litigation.
  - b. Pursuant to Government Code section 54957(b)(1), the Board will provide a performance evaluation for the General Manager.
  - c. Pursuant to Government Code Section 54956.9(d)(1), the Board will confer with legal counsel regarding existing litigation:
    1. *American Family Connect Property and Casualty, et al. v. County of Monterey, et al.*  
(Monterey County Superior Court Case No. 24CV000215)
    2. *Stephen Ray Acosta, et al. v. County of Monterey, et al.*  
(Monterey County Superior Court Case No. 24CV000428)
    3. *Mario Gonzalez, et al. v. State of California, et al.*  
(Santa Cruz Superior Court Case No. 23CV03022)
  - d. Pursuant to Government Code section 54956.8, the Board will confer with real property negotiators:
    - Property: Recycled Industrial Wastewater
    - Agency Negotiator(s): Ara Azhderian, General Manager
    - Negotiating Parties: City of Salinas and Monterey One Water
    - Under Negotiation: Price and terms.

**WRAG  
24-034**

*Note: Continuance of Closed Session to be held at the conclusion of the Board's Regular Agenda, or at any other time during the course of the meeting*

*announced by the Chairperson of the Board. The public may comment on Closed Session items prior to the Board's recess to Closed Session.*

### **Recess to Closed Session**

### **Reconvene Meeting at 9:30 A.M.**

### **Pledge of Allegiance**

**ADDITIONS AND CORRECTIONS BY CLERK: The Clerk of the Board will announce agenda corrections and proposed additions, which may acted on by the Board as provided in Sections 54954.2 of the California Government Code.**

### **Public Comment**

### **Presentations**

2. Hold a workshop to review the Monterey County Water Resources Agency Fiscal Year 2024 - 25 Requested Budget and provide direction to staff: **WRAG 24-046**

- Introduction. (Presenter: Ara Azhderian)
- FY25 Budget Review (Presenter: Nan Kyung Kim)
- Status on the Nacimiento Dam Hydroelectric Power Plant. (Presenter: Manuel Saavedra & Elise Ramirez)
- Monterey County Water Recycling Projects Budget. (Presenter: Pete Vannerus & Jason Demers)
- Safety of Dams Regulatory Requirements. (Presenter: Elise Ramirez & Mark Foxworthy)
- Recapitulation and Next Steps. (Presenter: Ara Azhderian)

**Attachments:** FY25 Budget Book  
WRA FY25 Budget Review PPT  
FY25 Budget Augmentation Requests

3. Update on the expansion and enhancement of the Agency's Groundwater Extraction Management Systems (GEMS).(Presenter: Ara Azhderian) **WRAG 24-041**

**Attachments:** SVB-WRA GEMS Update PPT

### **Consent Calendar**

4. Approve the Action Minutes of February 20, 2024, and Special Board of Directors Meeting Action Minutes of February 7, 2024. **WRAG 24-036**

**Attachments:** Draft BOD Minutes February 20, 2024  
Draft SPECIAL BOD Minutes February 7, 2024

5. Approve Amendment No. 2 of the Agreement for Professional Services with GEI Consultants, Inc, in the amount of \$70,000 for engineering design & project management services for storm damage repair design and implementation of the Nacimiento Dam Hydro-plant's South Access Road; and authorizing the General Manager to execute the amendment. (Staff: Mark Foxworthy)

[WRAG](#)  
[24-042](#)

**Attachments:** [Board Report](#)  
[Amendment No. 2 - GEI Consultants, Inc. \(Storm Repairs\)](#)  
[Agreement for Professional Services](#)  
[Amendment No. 1](#)  
[Board Order](#)  
[Executed Board Order # 24-005 GEI Amendment No. 2](#)

6. Approve an Agreement for Services with Industrial Machine Shop for a new contract for \$250,000 for: electrical motor repair and rebuilding, well pump and equipment inspection, rebuilding, machining, as well as fabrication services for the Recycle Water Project Facilities; and authorize the General Manager to execute the agreement. (Staff: Peter Vannerus)

[WRAG](#)  
[24-045](#)

**Attachments:** [Board Report](#)  
[Agreement for Services with IMS](#)  
[Board Order](#)  
[Executed Board Order#24-006 Industrial Machine Contract for Recycle Water Projects](#)

7. Recommend that the Monterey County Water Resources Agency Board of Supervisors approve and authorize the General Manager of the Monterey County Water Resources Agency to accept a donation of funding for chain link fencing valued at \$4,500 from Cypress Creek Apartments.  
(Staff: Mallory Roberts)

[WRAG](#)  
[24-043](#)

**Attachments:** [Board Report](#)  
[Letter to Cypress Creek Apartments](#)  
[Letter Fence Work Cypress Creek Ownership Before and After Photos](#)  
[Board Order](#)  
[Executed Board Order# 24-007 Donation for Casentini Street Cleanup](#)

8. Approve an Intellectual Property Rights Transfer Agreement with the Grower-Shipper Association of Central California, Inc. for an updated flood model of the Salinas River, and authorize the General Manager to execute the Agreement. (Staff: Ara Azhderian)

[WRAG](#)  
[24-044](#)

- Attachments:** [Board Report](#)  
[Intellectual Property Transfer Agreement \(GS signed\)](#)  
[Board Order](#)  
[Executed Board Order#24-008 Intellectual Property Rights](#)

**12:00 P.M. - Recess to Lunch to Closed Session.**

**1:00 P.M. - Reconvene**

**Key Information and Calendar of Events**

9. March, April and May 2024 Calendars.

**WRAG  
24-037**

- Attachments:** March 2024  
April 2024  
May 2024

**General Manager's Report**

10.
  - Personnel Update
  - Monterey One Reconciliation
  - Carmel River Flood Model Update Funding
  - Other

**WRAG  
24-038**

**Committee Reports**

11. Committee Agenda's and Cancellation Notices for February and March 2024:  
  - Water Resources Agency Reservoir Operations Advisory Committee
  - Water Resources Agency Personnel and Administration Committee
  - Water Resources Finance Committee
  - Water Resources Agency Basin Management Advisory Committee
  - Water Resources Planning Committee

**WRAG  
24-039**

- Attachments:** Final ResOps Agenda February 29, 2024  
Personnel & Administration March Cancellation Notice  
Final Finance Agenda March 1, 2024  
BMAC March Cancellation Notice  
Final Planning Agenda March 6, 2024

**Information Items**

12. Reservoir Storage and Release Update. (Staff: Joseph Klein, Peter Kwiek)

**WRAG  
24-040**

**Attachments:** Reservoir Storage Release Update

**Board of Directors Comments**

**Adjournment**



# County of Monterey

## Item No.1

### Board Report

Board of Supervisors  
Chambers  
168 W. Alisal St., 1st Floor  
Salinas, CA 93901

Legistar File Number: WRAG 24-034

March 18, 2024

**Introduced:** 3/12/2024

**Current Status:** Draft

**Version:** 1

**Matter Type:** WR General Agenda

Closed Session under Government Code section 54950, relating to the following items:

a. Pursuant to Government Code section 54956.9(d)(2), the Board will confer with legal counsel regarding one matter of significant exposure to litigation.

b. Pursuant to Government Code section 54957(b)(1), the Board will provide a performance evaluation for the General Manager.

c. Pursuant to Government Code Section 54956.9(d)(1), the Board will confer with legal counsel regarding existing litigation:

1. *American Family Connect Property and Casualty, et al. v. County of Monterey, et al.*  
(Monterey County Superior Court Case No. 24CV000215)

2. *Stephen Ray Acosta, et al. v. County of Monterey, et al.*  
(Monterey County Superior Court Case No. 24CV000428)

3. *Mario Gonzalez, et al. v. State of California, et al.*  
(Santa Cruz Superior Court Case No. 23CV03022)

d. Pursuant to Government Code section 54956.8, the Board will confer with real property negotiators:

Property: Recycled Industrial Wastewater

Agency Negotiator(s): Ara Azhderian, General Manager

Negotiating Parties: City of Salinas and Monterey One Water

Under Negotiation: Price and terms.

*Note: Continuance of Closed Session to be held at the conclusion of the Board's Regular Agenda, or at any other time during the course of the meeting announced by the Chairperson of the Board. The public may comment on Closed Session items prior to the Board's recess to Closed Session.*



# County of Monterey

## Item No.2

### Board Report

Board of Supervisors  
Chambers  
168 W. Alisal St., 1st Floor  
Salinas, CA 93901

Legistar File Number: WRAG 24-046

March 18, 2024

**Introduced:** 3/13/2024

**Current Status:** Draft

**Version:** 1

**Matter Type:** WR General Agenda

Hold a workshop to review the Monterey County Water Resources Agency Fiscal Year 2024 - 25 Requested Budget and provide direction to staff:

- Introduction. (Presenter: Ara Azhderian)
- FY25 Budget Review (Presenter: Nan Kyung Kim)
- Status on the Nacimiento Dam Hydroelectric Power Plant.  
(Presenter: Manuel Saavedra & Elise Ramirez)
- Monterey County Water Recycling Projects Budget.  
(Presenter: Pete Vannerus & Jason Demers)
- Safety of Dams Regulatory Requirements. (Presenter: Elise Ramirez & Mark Foxworthy)
- Recapitulation and Next Steps. (Presenter: Ara Azhderian)



# MONTEREY COUNTY WATER RESOURCES AGENCY

## Fiscal Year 2024-2025 Recommended Budget





The Monterey County Water Resources Agency was formed in 1947 by State law, which established the Monterey County Flood Control and Water Conservation District and was organized as a division of the Department of Public Works. In the late 50s, the Monterey County Flood Control and Water Conservation District became autonomous with the district Engineer reporting directly to the Board of Supervisors. In January of 1991, new legislation (SB 2580) changed the name of the Agency to the Monterey County Water Resources Agency to more accurately reflect its powers and functions. In addition to the Agency's responsibility for flood plain management and emergency flood-related preparedness, the Agency has jurisdiction over matters pertaining to water within the entire area of the County of Monterey, including both incorporated and unincorporated areas. The Agency is authorized to conserve water in any manner, to buy, sell and purvey water, to prevent the waste or diminution of the water extractions which are determined to be harmful to the groundwater basin.

# Monterey County Water Resources Agency

## **HISTORY**

The Salinas River was the original main source for irrigation in the Salinas Valley, but by 1872, farmers turned to groundwater. By 1900, wells were so common to the point by 1930 there were concerns about seawater intrusion. Combined with continual flooding in the valley, the concerns prompted the formation of the Monterey County Flood Control and Water Conservation District (MCFCWCD) in 1947.

The MCFCWCD became the Monterey County Water Resources Agency (“Agency”) in 1991, with an updated mandate to provide for the control of flood and storm waters, conservation of such waters through storage and percolation, control of groundwater extraction, protection of water quality, reclamation of water, exchange of water, and the construction and operation of hydroelectric power facilities. MCWRA area covers all of Monterey County, including the Salinas Valley Groundwater Basin.

## **PRESENT**

The Agency has a nine-member Board of Directors. The board is made up of members appointed by the Monterey County Farm Bureau, Monterey Grower-Shipper Association, the County Agricultural Advisory Committee, five members appointed by the County Board of Supervisors (one from each district), and a member appointed by the Mayor Select Committee. The board is under the governance of the Monterey County Water Resources Agency Board of Supervisors.

The FY 2024-25 Recommended Budget attempts to meet Agency’s 5-year strategic plan Goal C: Financial Stability to ensure long term financial stability with sufficient funding to pay for Agency obligations and align expenditures with revenues.

## MCWRA Funds:

MCWRA Funds are comprised of fourteen (14) funds as below:

### Special Assessment Funds:

Fund 116 - Salinas Valley Water Project Dam Operations & Maintenance and Administration

Fund 131 - Castroville Seawater Intrusion Project (CSIP) Operations

Fund 132 - Salinas Valley Reclamation Project (SVRP) Operations

Fund 134 - Salinas River Diversion Facility (SRDF) Operations

### Flood Assessment Funds:

Fund 112 - Pajaro Levee

Fund 121 - Soledad Storm Drain

Fund 122 - Reclamation Ditch

Fund 124 - San Lorenzo Creek

Fund 127 - Moro Cojo Slough

### Debt Service Funds:

Fund 303 - CSIP Debt Service

Fund 313 - SVWP Monterey Financing Authority Debt Service

### Other Funds:

Fund 111 - WRA Administration

Fund 130 - Hydro-Electric Operations

Fund 426 - Interlake Tunnel and Spillway Modification DWR Grant Project/Study (ILT)

# Table of Contents

<b>Summary of Recommendations</b> .....	<b>6</b>
<b>Strategic Plan: Proposed Goals</b> .....	<b>9</b>
<b>Agency Organizational Chart</b> .....	<b>12</b>
<b>Agency Personnel and Salaries</b> .....	<b>13</b>
<b>All Funds Consolidated Budget</b> .....	<b>14</b>
<b>Fund 111 - Administration</b> .....	<b>18</b>
<b>Fund 112 - Pajaro Levee</b> .....	<b>21</b>
<b>Fund 116 - Dam Operations</b> .....	<b>26</b>
<b>Fund 121 - Soledad Storm Drain</b> .....	<b>30</b>
<b>Fund 122- Reclamation Ditch</b> .....	<b>34</b>
<b>Fund 124 - San Lorenzo Creek</b> .....	<b>38</b>
<b>Fund 127 - Moro Cojo Slough</b> .....	<b>42</b>
<b>Fund 130 - Hydro-Electric Operations</b> .....	<b>46</b>
<b>Fund 131 - Castroville Seawater Intrusion Project (CSIP) Operations</b> .....	<b>49</b>
<b>Fund 132 - Salinas Valley Reclamation Plant (SVRP) Operations</b> .....	<b>54</b>
<b>Fund 134 - Salinas River Diversion Facility (SRDF) Operations</b> .....	<b>58</b>
<b>Fund 303 - Castroville Seawater Intrusion Project (CSIP) Debt Service</b> .....	<b>61</b>
<b>Fund 313 - Salinas Valley Water Project (SVWP) Debt Service</b> .....	<b>63</b>
<b>Fund 426 - Interlake Tunnel Project</b> .....	<b>65</b>
<b>Consolidated Fund Balance Summary</b> .....	<b>67</b>

# Summary of Recommendations

The Monterey County Water Resources Agency (“Agency”) Fiscal Year 2024-25 (FY25) Recommended Budget requests the combined total appropriations of \$48,524,974 for all 14 Agency Funds. This is a decrease of 12% from \$54,086,209, the Amended Budget of Fiscal Year 2023-24 (FY24).

Total Full Time Equivalent (FTE) positions requested in the FY25 Recommended Budget is 57 FTE with 53 funded positions. Four (4) of total 57 positions are unfunded, and six (6) positions are partially funded. Total salary savings of both partially funded and unfunded position is \$1,126,831. A total amount of \$8,755,473 is allocated for salaries and benefits, which is 18% of the Recommended Budget.

Total amount budgeted for consultant service is \$24,212,530, which is 6% decrease from FY24. Monterey One Water payment is 4% decreased to \$9,163,033 and other consultant expense is 7% decreased to \$15,049,497, which includes total amount of \$8,775,000 grant reimbursable consultant services. The budget includes expenditures of grant activities, which includes the Salinas Valley Basin Groundwater Sustainability Agency (SVB GSA) subgrant, the Nacimiento Project with California Department of Water Resources (DWR) and Dam Safety Project with DWR. The budget also designates \$350,000 of Agency fund from Hydro-electric revenue to support efforts to secure external funding to continue the Interlake Tunnel Project (ILT) beyond completion of the ILT grant with DWR.

FY25 budget’s biggest increase over FY24 budget is with insurance cost, which is increased 41% to \$1,781,691. Estimated cost of general liability (GL) and pollution coverage through Public Risk Innovation, Solutions, and Management (PRISM) program is expected to increase by 73% to \$784,000 in FY25 and the Agency share of the County’s GL and property insurance allocations is increased by 23% to \$990,458.

FY25 is another year that the Agency will experience significant change with County’s Cost Plan charges. Its FY25 allocation is \$573,662 decreased from \$1,828,247 in FY24. Agency’s Cost Plan charge in FY23 was \$551,359.

A combined total debt payment in FY25 is \$4,439,338, nine percent (9%) of the Budget, which is comprised of bond payments for the Salinas Valley Water Project Bond (SVWP), annual loan payments for the Castroville Seawater Intrusion Project (CSIP) and the Salinas Valley Reclamation Project (SVRP). Fund transfers to the Debt Service Funds for CSIP loan and SVWP bond payments is estimated at \$3,423,338 or seven percent (7%) of the Budget.

Remaining expenditures are county department charges of \$823,259 and other services and supplies of \$3,616,209. The Budget recommends assignment of \$105,000 of Fund 116 to capital project reserve in Fund 116. In FY2022-23, Fund 111 received \$2,500,000 from the County of Monterey via Advance Funding Agreement to repair damages caused by 2023 winter storms

events. The FY25 Recommended Budget requests fund transfers of \$244,474 and \$200,000 of the Advance Funding Agreement payment from Fund 111 to Fund 122 and Fund 124, respectively to pay for repair expenses of 2023 winter storm damages,

The FY25 Recommended Budget estimates total revenue of \$43,058,808, which is 14% decrease from the FY24 Amended Budget revenue of \$50,097,830.

The estimated revenue assumes a 3% cost-of-living adjustment (COLA) increase to assessment charges and fees in FY25. The exact amount of the COLA adjustment is subject to change adopting the Consumer Price Index (CPI) of the San Francisco Bay Area which will be released on March 12, 2024. Annual COLA adjustments by the CPI percentage are authorized by MCWRA ordinances. The Recommended Budget estimates Ad-Valorem tax revenue at \$3,447,294 and total assessment revenue at \$17,631,168.

The budget includes estimates \$9,681,900 grant revenue from the following: the SVB GSA subgrant, the Nacimiento Project with DWR, Dam Safety Project with DWR, Section 6 HCP grants with CDFW, Integrated Regional Water Management (IRWM) grant with DWR. It also includes a federal assistance of \$900,000 for Castroville Seawater Intrusion Project. Additionally, the budget accounts for three grants that the Agency applied for in FY24.

Estimated combined revenue from Water Delivery fees and Services Charges is \$3,026,940. The Agency recommends water delivery charge in FY25 be \$64.60 per acre foot water delivered, increased by \$27.36 from \$37.24 in FY24. Revenue from Water Delivery Fee will fund funding gaps caused by increased utility and chemical costs at CSIP and SVRP operations since 2019. The Water Service charge in FY25 will receive a COLA adjustment by the CPI %.

The Recommended Budget includes \$794,474 of revenue transfer-in within Agency Funds, \$1,470,000 transfer revenue from other County departments and \$3,423,338 for debt payments, hydro-electronic revenue of \$1,140,961, and payments of \$614,070 from San Luis Obispo County.

Overall, FY25 budgeted expenditures exceed revenues by \$5,466,166, which will be financed with fund balance of Agency Funds. Ending Fund Balance of Agency's fund is estimated at \$14,780,857.

For the FY25 budget, the Agency attempted to right-size staffing level and incorporate staff requests as well as achieve structurally balanced budget, by setting expenses at the level sustainable by ongoing revenue. However, Agency's revenue growth does not support expenses needed for known operation and maintenance cost, needed staffing and major repair and replacement projects. The recommended budget reflects approximate \$8 million reductions made to cost estimated for preferred level of staffing and services and supplies. It is a budget constraint by current revenue growth rates and zone restrictions.

The Agency is working on interim and long-term plans to meet County fiscal guidelines where fund balances are not used to sustain ongoing operations. The financial plans will consider

organizational restructuring with a focus on service level and financial sustainability, as well as fund balance growth and positive cash balances.

# Strategic Plan: Proposed Goals

The Monterey County Water Resources Agency (Agency) Board of Directors adopted a five-year strategic plan in December 2020. The strategic plan developed and provided updates to the Agency's, vision mission, organizational values, and multi-year goals.

## Vision Statement

Be recognized throughout the region as a leader in water resource management through demonstrated knowledge, integrity, and the quality of our actions.

## Mission Statement

Manage water resources sustainably while minimizing impacts from flooding for present and future generations.

## Organizational Values

### Leadership

- Set a positive example for others in water resources management and flood control through our knowledge, integrity, and actions.

### Stewardship

- Operate with financial and environmental responsibility so the Agency continuously succeeds.

### Transparency

- Work in ways that are easily understood by stakeholders and the public, communicating effectively about Agency decisions, actions, resources, and progress.

### Integrity

- Act with openness, honesty, and consistency, showing no favoritism and utilizing professional standards for decision making.

### Public service

- Work in a way that brings pride upon the Agency, showing that we care about quality and safety, are accountable, think long term, and provide excellent service to the community we serve.

### Collaboration

- Work with stakeholders and related organizations to advance our mission and vision.

## Multi-Year Goals



## Proposed Goals

The Monterey County Water Resources Agency Board of Directors held an annual Strategic Plan Update Workshop in January 2024. This exercise summarized accomplishments and updates on progress for implementation of year three of the adopted plan. The group reviewed and discussed seven proposed goals for the next two years. The discussion about the goals included sharing success indicators for each. A summary of the discussions regarding each goal is provided in below.

Goal	Summary of Discussion
<b>1. Recycled water system master planning</b>	<ul style="list-style-type: none"> <li>• Optimized Castroville Seawater Intrusion Project (CSIP)</li> <li>• CSIP expansion – maximize the diversion facility</li> <li>• Priorities are as follows:                             <ul style="list-style-type: none"> <li>○ Treated water</li> <li>○ River water</li> <li>○ Well water</li> </ul> </li> <li>• We understand what goes in and what comes out and it adds up</li> <li>• Successful financial and flow audit results to improve information regarding what is going on</li> </ul>
<b>2. Project feasibility studies to address seawater intrusion/groundwater sustainability</b>	<ul style="list-style-type: none"> <li>• List of projects to start the funding process</li> <li>• Reduce seawater intrusion</li> <li>• CSIP expansion</li> <li>• Extraction barrier</li> <li>• Good science that is well vetted and reviewed</li> <li>• This is a Groundwater Sustainability Agency (GSA)-led project, so we need to work with them</li> </ul>

Goal	Summary of Discussion
<b>3. Condition assessments of facilities to support capital replacement and improvement plan</b>	<ul style="list-style-type: none"> <li>• Efficiency may increase if we keep the river clean</li> <li>• Create a capital improvement plan (CIP) list that shows how well we are doing</li> <li>• Create and maintain a checklist of projects and needed investments</li> <li>• This is a work in progress. We need to plan better.</li> </ul>
<b>4. Relationship building with other water resources agencies</b>	<ul style="list-style-type: none"> <li>• Quarterly General Manager-Chair meetings to build relationships</li> <li>• Continue building on this</li> <li>• Water agency general managers work well together</li> <li>• Association of California Water Agencies (ACWA) connection must be used</li> <li>• Agency partners with other agencies to advance initiatives of mutual benefit</li> </ul>
<b>5. Public information and community engagement plan</b>	<ul style="list-style-type: none"> <li>• Dedicated staff person</li> <li>• Stakeholders can clearly articulate what the Agency is doing and where it is headed so they support the direction</li> <li>• We will need a staff person for this</li> <li>• Community support of Proposition 218 funding</li> <li>• Need to get funding first</li> </ul>
<b>6. Funding strategies and implementation plan</b>	<ul style="list-style-type: none"> <li>• Revisit meters and price per acre-foot</li> <li>• Use Proposition 218 funds for the dam repair</li> <li>• Regional consensus</li> <li>• Use it, pay for it</li> <li>• Charge extraction fee</li> <li>• Ensure that the Agency has the funds to address its priorities</li> </ul>
<b>7. Legislative platform and engagement strategy</b>	<ul style="list-style-type: none"> <li>• State/federal grants for dam repairs. Explore grant writers</li> <li>• Lobbyist</li> <li>• Educate government officials on Monterey County water issues at the federal and state level</li> <li>• Hire dedicated/specialized staff to respond to environmental regulations</li> <li>• Staying involved with local legislative committees</li> <li>• Maintain a presence at the state and federal level</li> </ul>

# Monterey County Water Resources Agency

## FY25 Positions – Proposed

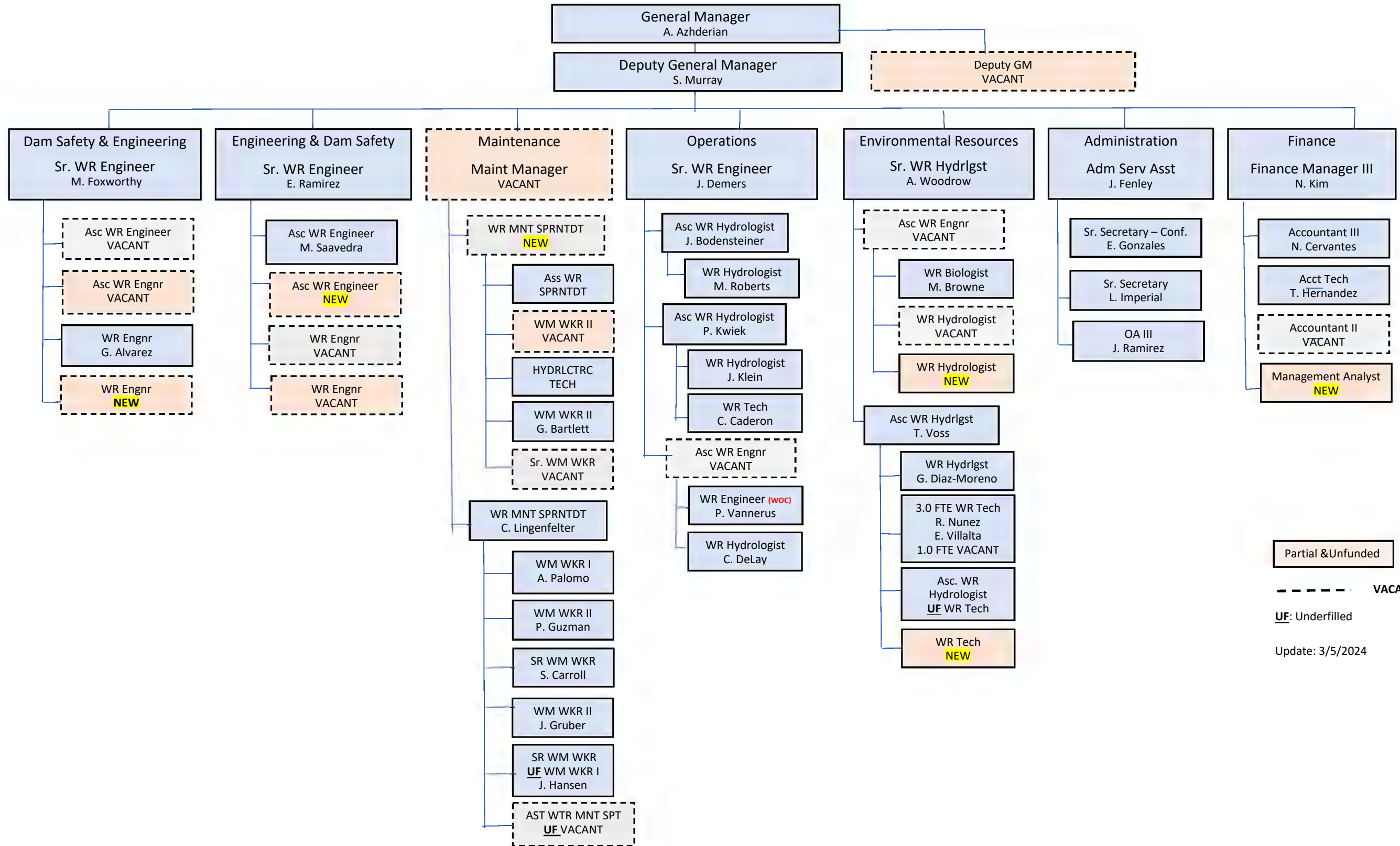

Partial & Unfunded

--- VACANT

UF: Underfilled

Update: 3/5/2024



# MONTEREY COUNTY WATER RESOURCES AGENCY

## PERSONNEL AND SALARIES

<u>CLASSIFICATION / DESCRIPTION</u>	FY 2023-24 Adopted		FY 2024-25 Recommended		DIFFERENCE
	<u>NUMBER</u>	<u>AMOUNT</u>	<u>NUMBER</u>	<u>AMOUNT</u>	
<b><u>FUNDED POSITIONS (SALARIES &amp; BENEFITS)*</u></b>					
Accounting Technician	1	115,012	1	124,058	9,046
Accountant II	1	137,407	1	145,626	8,220
Accountant III	1	166,874	1	210,635	43,760
Administration Services Assistant	1	178,662	1	179,944	1,282
Assistant Water Maintenance Superintendent	2	259,267	2	281,911	22,644
Associate Water Resources Engineer	5	1,026,567	5	958,580	(67,987)
Associate Water Resources Hydrologist*	4	756,694	4	758,101	1,406
Deputy General Manager - Water Resources Agency	1	312,013	1	378,290	66,277
Engineering Aide II	1	115,898	0		(115,898)
Finance Manager III	1	260,065	1	280,663	20,598
General Manager - Water Resources Agency	1	396,157	1	378,147	(18,010)
Hydroelectric Technician	1	137,335	1	106,230	(31,105)
Maintenance Manager	1	208,249	1	176,392	(31,857)
Management Analyst II			1	119,629	119,629
Office Assistant III	1	99,005	1	104,131	5,125
Senior Secretary			1	127,729	127,729
Senior Secretary - Confidential	1	112,762	1	115,425	2,662
Senior Water Maintenance Worker	3	299,688	3	282,254	(17,435)
Senior Water Resources Engineer	2	567,458	3	731,602	164,144
Senior Water Resources Hydrologist	1	218,984	1	245,646	26,662
Water Maintenance Superintendent	1	175,822	2	343,830	168,008
Water Maintenance Worker I	1	77,391	1	75,654	(1,737)
Water Maintenance Worker II	3	320,504	3	324,567	4,064
Water Resources Biologist	1	156,932	1	111,473	(45,458)
Water Resources Engineer	4	561,156	4	547,125	(14,031)
Water Resources Hydrologist	5	728,699	6	714,158	(14,542)
Water Resources Technician	4	427,758	5	481,772	54,014
<b>*SALARIES AND BENEFITS SUBTOTAL</b>	<b>48.0</b>	<b>7,816,361</b>	<b>53.0</b>	<b>8,303,571</b>	<b>487,210</b>
<b>SALARY ADJUSTMENTS:</b>					
Temporary Employees		148,099		159,416	11,317
Vacation Buybacks		119,524		115,200	(4,324)
Overtime		36,188		26,612	(9,576)
Other Post-Employment Benefits		13,617		439	(13,178)
Unemployment		5,630		4,664	(966)
Worker's Compensation		154,396		186,554	32,158
Wellness Plan		3,400		2,888	(512)
<b>SALARY ADJUSTMENTS SUBTOTAL</b>		<b>480,854</b>		<b>495,773</b>	<b>14,919</b>
<b>*SALARIES AND BENEFITS TOTAL</b>	<b>48.0</b>	<b>\$8,297,215</b>	<b>53.0</b>	<b>\$8,799,344</b>	<b>\$502,130</b>
<b><u>UNFUNDED POSITIONS</u></b>					
Associate Water Resources Engineer	0		1		
Deputy General Manager	1		1		
Senior Water Resources Hydrologist	1		0		
Water Maintenance Worker II	1		1		
Water Resources Engineer	0		1		
<b>SUTOTAL UNFUNDED</b>	<b>3</b>		<b>4</b>		
<b>TOTAL POSITIONS</b>	<b>51</b>		<b>57</b>		

## All Funds Consolidated Budget

## FY25 Budget Summary

### Revenues

Ad-Valorem Taxes	3,447,294
Special Assessments	17,631,168
San Luis Obispo County Payment	614,070
Grants	8,781,900
Federal Aid (FEMA, Etc)	900,000
Lease & Interest Revenue	960,081
Development & Annexation Fees	208,000
Hydroelectric Revenue	1,140,961
Water Delivery & Service Fees	3,026,940
Other Revenues	660,582
Fund Transfer In	2,264,474
Debt Service Funds	3,423,338

<b>Total Revenues</b>	<b>43,058,808</b>
-----------------------	-------------------

### Expenditures

Salaries & Benefits	8,755,473
General Liability & Pollution Insurances	1,781,691
County Cost Allocation Plan	573,662
Consultant (Non M1W)	15,049,497
Monterey One Water	9,163,033
Equipment	0
County Department Charges	823,259
Other Services Supplies	3,616,209
Fund Transfers Out	899,474
Debt Payments (CSIP, SVRP, SVWP)	4,439,338
Debt Service Funds	3,423,338

<b>Total Expenditures</b>	<b>48,524,974</b>
---------------------------	-------------------

<b>Impact to Fund Balance</b>	<b>(5,466,166)</b>
-------------------------------	--------------------

<b>Est. Beginning Fund Balance</b>	<b>20,247,023</b>
------------------------------------	-------------------

<b>Est. Ending Fund Balance</b>	<b>14,780,857</b>
---------------------------------	-------------------



## All Funds - FY25 Budget Expenditure & Revenue Details

FUND	Budget Object	Budget Object Name	FY25 Recommended	FY24 Amended	FY23 Actual
ALL	6111	Regular Employees	5,164,272	5,255,934	3,785,652
ALL	6112	Temporary Employees	159,416	188,099	300,059
ALL	6113	Overtime	26,612	38,742	99,572
ALL	6121	PERS	1,383,520	1,255,776	909,072
ALL	6122	Other Post-Employment Benefits	439	13,617	20,509
ALL	6131	FICA	367,103	126,624	183,146
ALL	6132	Medicare	89,429	80,338	61,144
ALL	6141	Flex Co Paid Insurance-Pretax	103,680	92,880	123,800
ALL	6142	Life Insurance	5,415	4,260	3,141
ALL	6143	Long-Term Disability Insurance	6,555	5,556	3,967
ALL	6144	Short-Term Disability Insurance	8,266	6,444	4,185
ALL	6145	Dental Insurance	26,071	22,176	16,353
ALL	6147	Vision Insurance	8,064	6,864	5,428
ALL	6148	Unemployment Insurance	4,664	5,630	4,195
ALL	6161	Workers Compensation Insurance	186,554	154,396	146,592
ALL	6171	Employee Assistance Program	1,371	-	61
ALL	6173	Flex-Benefit Plan Contribution	1,180,129	1,054,836	624,003
ALL	6174	Special Benefits	31,025	21,643	27,955
ALL	6175	Wellness Plan	2,888	3,400	2,484
ALL	6222	Uniforms and Safety Equipment	9,258	9,852	16,317
ALL	6231	Communication Charges - External	34,822	16,195	18,734
ALL	6241	Food	4,550	3,000	4,998
ALL	6251	Cleaning and Janitorial	1,980	2,100	1,800
ALL	6261	Insurance - General Liability (Non-recoverable)	414,306	577,006	373,309
ALL	6262	Insurance - General Liability (Recoverable)	307,608	41,797	24,949
ALL	6266	Insurance - Property	268,544	183,261	131,470
ALL	6268	Insurance - Other	791,233	458,322	409,842
ALL	6311	Bldg Improvements/Maintenance -External	481,315	767,146	1,937,105
ALL	6312	Bldg Improvements/Maintenance -Internal	-	-	1,905
ALL	6321	Equipment Maintenance	169,222	624,081	187,254
ALL	6351	Membership Fees	31,227	22,875	3,641
ALL	6361	Noncapital Equipment	154,272	372,995	113,233
ALL	6381	Advertising	1,500	1,100	3,885
ALL	6384	Miscellaneous Supplies	10,500	24,853	25,286
ALL	6401	Books/Periodicals & Subscriptions	31,750	13,270	12,973
ALL	6402	Bottled Water	3,450	3,100	2,483
ALL	6404	Courier Services - External	950	1,700	769
ALL	6405	Courier Services - Internal	6,963	9,144	6,363
ALL	6406	Mail Handling Charges	403	747	734
ALL	6407	Minor Computer Hardware	16,800	21,500	1,120
ALL	6408	Minor Computer Software	17,706	29,868	13,545
ALL	6409	Minor Equipment and Furnishings	58,300	30,869	15,841
ALL	6410	Office Supplies	6,863	5,600	4,856

## All Funds - FY25 Budget Expenditure & Revenue Details

FUND	Budget Object	Budget Object Name	FY25 Recommended	FY24 Amended	FY23 Actual
ALL	6411	Postage and Shipping	5,144	4,143	2,167
ALL	6412	Printing, Graphics & Binding- External	450	1,160	613
ALL	6414	Other Office Expense	6,350	341	43
ALL	6415	Records Retention Charge - Internal	749	577	600
ALL	6601	Accounting & Auditing Charges	59	2,252	-
ALL	6603	Data Processing Services - Internal	560,000	724,842	269,483
ALL	6605	Laboratory Services	40,000	36,087	20,602
ALL	6606	Legal Service - External	70,000	24,000	51,127
ALL	6607	Legal Service - Internal	250,000	340,405	170,018
ALL	6609	Other Personnel Services	26,000	65,615	34,931
ALL	6611	Staff Training Services	84,373	21,000	20,485
ALL	6613	Other Professional & Special Services	24,212,531	25,659,391	12,949,297
ALL	6801	Publications and Legal Notices	5,630	11,745	2,147
ALL	6811	Rents and Leases - Buildings	1,755,338	1,755,338	1,758,338
ALL	6821	Rents and Leases - Equipment	110,881	200,394	158,249
ALL	6835	Other Special Departmental Expenses	464,156	432,758	931,664
ALL	6861	Conference/Lodging/Meals/Travel	129,000	23,700	3,225
ALL	6862	Employee Mileage Reimbursement	3,750	2,750	1,524
ALL	6864	Fleet Service Charge	133,644	84,837	104,785
ALL	6866	Vehicle Maintenance - External	56,821	35,067	44,519
ALL	6881	Utilities	234,473	158,265	287,635
ALL	7013	Reimbursement to Other Gvnmt Agency	390,000	403,074	155,339
ALL	7041	Bond Principal Payments	860,000	860,000	825,000
ALL	7051	Other Debt Retirement	1,018,000	1,018,000	1,085,360
ALL	7061	Interest On Bonds	895,338	895,338	933,338
ALL	7082	Other Interest	650,000	650,000	472,695
ALL	7101	Rights Of Way	3,588	509,588	2,775
ALL	7121	Taxes and Assessments	70,150	66,618	66,486
ALL	7201	Contribution to Other Agency	1,510,778	2,587,548	992,560
ALL	7301	Cost Plan Charges	573,662	1,828,247	551,357
ALL	7304	Interfund Reimbursement	-	-	(108,975)
ALL	7531	Equipment	-	-	300,222
ALL	7532	Vehicles	-	149,250	68,762
ALL	7533	Right-To-Use Expenditure - Equipment	62,641	73,486	23,930
ALL	7534	Right-to-Use Expenditure - Vehicles	195,000	127,493	115,137
ALL	7614	Operating Transfers Out	2,567,474	4,549,304	2,194,216
ALL	4010	Property Tax - Current Secured	2,951,389	2,652,348	2,880,477
ALL	4015	Property Tax - Current Unsecured	125,133	109,063	121,981
ALL	4025	Property Tax - Prior Secured	40,667	31,998	38,016
ALL	4030	Property Tax - Prior Unsecured	858	2,022	568
ALL	4035	Property Tax - Current Supplemental	89,786	60,256	85,115
ALL	4040	Property Tax - Prior Supplemental	3,124	3,927	2,633
ALL	4090	Other Property Taxes	225,620	214,003	221,197

## All Funds - FY25 Budget Expenditure & Revenue Details

FUND	Budget Object	Budget Object Name	FY25 Recommended	FY24 Amended	FY23 Actual
ALL	4300	Other Licenses and Permits	191,376	184,840	189,203
ALL	4600	Investment Income	635,281	211,528	433,800
ALL	4675	Rents, Concessions, and Leases	2,080,138	2,091,338	1,969,583
ALL	4750	Royalties	614,070	582,600	582,468
ALL	5030	Homeowners Property Tax Relief	10,717	10,700	10,669
ALL	5050	Other State Aid	8,781,900	15,591,540	2,166,324
ALL	5290	Federal Aid Other	900,000	2,437,750	-
ALL	5415	Special Assessments	17,631,168	17,629,231	16,340,406
ALL	5505	Planning and Engineering Services	-	-	5,513
ALL	5750	Other Services and Non-Taxable Sales	4,384,741	3,609,091	1,956,367
ALL	5855	Other Reimbursement	460,366	338,198	85,674
ALL	5870	Miscellaneous Revenues	-	-	8,077
ALL	5940	Operating Transfers In	3,932,474	4,337,397	10,144,216

EXPENDITURES:	48,524,974	54,860,209	34,123,384
REVENUES:	43,058,808	50,097,830	37,242,287

## FUND 111 - Administration Fund

## FY25 Budget Summary

### Revenues

Ad-Valorem Taxes	3,072,648
Special Assessments (Zone 2C)	1,145,102
San Luis Obispo County Payment	0
Grants	242,000
Federal Aid (FEMA, Etc)	0
Lease & Interest Revenue	115,381
Development & Annexation Fees	208,000
Hydroelectric Revenue	0
Water Delivery & Service Fees	0
Other Revenues	195,481
Fund Transfer In	0
Debt Service Funds	0
<b>Total Revenues</b>	<b>4,978,612</b>

### Expenditures

Salaries & Benefits	1,820,159
General Liability & Pollution Insurances	188,234
County Cost Allocation Plan	110,474
Consultant (Non M1W)	1,605,601
Monterey One Water	0
Equipment	0
County Department Charges	129,671
Other Services Supplies	524,605
Fund Transfers Out	444,474
Debt Payments (CSIP, SVRP, SVWP)	1,755,338
Debt Service Funds	0
<b>Total Expenditures</b>	<b>6,578,556</b>

**Impact to Fund Balance (1,599,944)**

**Est. Beginning Fund Balance 3,846,022**

**Est. Ending Fund Balance 2,246,078**

#### Authorized Fund Transfers:

- > Fund 111 Fund Balance Transfer of \$244,474 to Fund 122 for 2023 winterstorm repair
- > Fund 111 Fund Balance Transfer of \$200,000 to Fund 124 for 2023 winterstorm repair



## Fund 111 - FY25 Budget Expenditure & Revenue Details

FUND	Unit	Appt	Budget Object	Budget Object Name	FY25 Recommended	FY24 Amended	FY23 Actual
111	8267	WRA001	6111	Regular Employees	1,150,990	1,014,951	696,869
111	8267	WRA001	6112	Temporary Employees	6,800	2,257	106,581
111	8267	WRA001	6113	Overtime	7,034	7,254	32,909
111	8267	WRA001	6121	PERS	275,707	245,721	160,377
111	8267	WRA001	6122	Other Post-Employment Benefits	189	2,649	9,400
111	8267	WRA001	6131	FICA	73,073	24,538	36,491
111	8267	WRA001	6132	Medicare	17,745	15,902	12,393
111	8267	WRA001	6141	Flex Co Paid Insurance-Pretax	21,021	18,066	75,687
111	8267	WRA001	6142	Life Insurance	1,038	888	556
111	8267	WRA001	6143	Long-Term Disability Insurance	1,046	1,104	693
111	8267	WRA001	6144	Short-Term Disability Insurance	1,318	1,224	734
111	8267	WRA001	6145	Dental Insurance	5,451	4,464	3,086
111	8267	WRA001	6147	Vision Insurance	1,707	1,356	1,057
111	8267	WRA001	6148	Unemployment Insurance	2,012	1,096	1,923
111	8267	WRA001	6161	Workers Compensation Insurance	23,683	30,031	26,680
111	8267	WRA001	6171	Employee Assistance Program	288	-	9
111	8267	WRA001	6173	Flex-Benefit Plan Contribution	224,590	189,900	101,101
111	8267	WRA001	6174	Special Benefits	5,673	4,120	5,708
111	8267	WRA001	6175	Wellness Plan	794	705	2,484
111	8267	WRA001	6222	Uniforms and Safety Equipment	400	1,000	1,425
111	8267	WRA001	6231	Communication Charges - External	7,526	10,000	11,836
111	8267	WRA001	6241	Food	4,300	2,500	3,381
111	8267	WRA001	6261	Insurance - General Liability (Non-recoverable)	16,622	68,665	67,942
111	8267	WRA001	6262	Insurance - General Liability (Recoverable)	2,138	4,974	4,541
111	8267	WRA001	6266	Insurance - Property	34,095	21,809	23,928
111	8267	WRA001	6268	Insurance - Other	135,379	54,542	49,834
111	8267	WRA001	6311	Bldg Improvements/Maintenance -External	64,590	50,000	818,294
111	8267	WRA001	6312	Bldg Improvements/Maintenance -Internal	-	-	1,561
111	8267	WRA001	6321	Equipment Maintenance	21,000	59,750	13,581
111	8267	WRA001	6351	Membership Fees	7,986	12,000	2,906
111	8267	WRA001	6361	Noncapital Equipment	15,124	55,500	28,971
111	8267	WRA001	6381	Advertising	1,000	300	-
111	8267	WRA001	6384	Miscellaneous Supplies	1,000	7,000	4,623
111	8267	WRA001	6401	Books/Periodicals & Subscriptions	9,186	4,000	4,345
111	8267	WRA001	6402	Bottled Water	600	1,200	421
111	8267	WRA001	6404	Courier Services - External	250	1,000	186
111	8267	WRA001	6405	Courier Services - Internal	1,574	1,036	1,158
111	8267	WRA001	6406	Mail Handling Charges	91	118	116
111	8267	WRA001	6407	Minor Computer Hardware	5,500	15,000	770
111	8267	WRA001	6408	Minor Computer Software	8,106	8,106	4,301
111	8267	WRA001	6409	Minor Equipment and Furnishings	19,800	9,800	8,035
111	8267	WRA001	6410	Office Supplies	5,563	5,000	4,719
111	8267	WRA001	6411	Postage and Shipping	1,164	651	387
111	8267	WRA001	6412	Printing, Graphics & Binding- External	350	650	33
111	8267	WRA001	6414	Other Office Expense	1,300	300	-
111	8267	WRA001	6415	Records Retention Charge - Internal	170	91	73
111	8267	WRA001	6601	Accounting & Auditing Charges	-	928	-
111	8267	WRA001	6603	Data Processing Services - Internal	70,122	118,074	62,601
111	8267	WRA001	6605	Laboratory Services	10,000	30,000	15,764
111	8267	WRA001	6606	Legal Service - External	10,000	10,000	4,627
111	8267	WRA001	6607	Legal Service - Internal	56,550	89,434	99,364

## Fund 111 - FY25 Budget Expenditure & Revenue Details

FUND	Unit	Appt	Budget Object	Budget Object Name	FY25 Recommended	FY24 Amended	FY23 Actual
111	8267	WRA001	6609	Other Personnel Services	-	-	2,050
111	8267	WRA001	6611	Staff Training Services	7,285	3,500	9,735
111	8267	WRA001	6613	Other Professional & Special Services	1,605,601	360,900	454,036
111	8267	WRA001	6801	Publications and Legal Notices	2,500	2,500	1,238
111	8267	WRA001	6811	Rents and Leases - Buildings	1,755,338	1,755,338	1,758,338
111	8267	WRA001	6821	Rents and Leases - Equipment	7,000	17,018	(30,408)
111	8267	WRA001	6835	Other Special Departmental Expenses	19,000	15,000	27,318
111	8267	WRA001	6861	Conference/Lodging/Meals/Travel	56,000	3,500	725
111	8267	WRA001	6862	Employee Mileage Reimbursement	2,000	1,250	1,524
111	8267	WRA001	6864	Fleet Service Charge	32,515	12,174	36,757
111	8267	WRA001	6866	Vehicle Maintenance - External	13,901	3,783	4,284
111	8267	WRA001	6881	Utilities	46,095	14,631	76,454
111	8267	WRA001	7013	Reimbursement to Other Gvnmt Agency	78,480	137,030	54,639
111	8267	WRA001	7101	Rights Of Way	3,588	3,588	2,775
111	8267	WRA001	7121	Taxes and Assessments	350	918	319
111	8267	WRA001	7301	Cost Plan Charges	110,474	379,179	100,346
111	8267	WRA001	7304	Interfund Reimbursement	-	-	(108,975)
111	8267	WRA001	7531	Equipment	-	-	72,389
111	8267	WRA001	7532	Vehicles	-	21,525	-
111	8267	WRA001	7533	Right-To-Use Expenditure - Equipment	14,863	14,481	23,930
111	8267	WRA001	7534	Right-to-Use Expenditure - Vehicles	47,447	18,296	46,693
111	8267	WRA001	7614	Operating Transfers Out	444,474	400,000	-
111	8267	WRA001	4010	Property Tax - Current Secured	2,598,338	2,272,974	2,515,692
111	8267	WRA001	4015	Property Tax - Current Unsecured	111,466	84,545	98,715
111	8267	WRA001	4025	Property Tax - Prior Secured	36,110	27,137	35,033
111	8267	WRA001	4030	Property Tax - Prior Unsecured	853	1,376	467
111	8267	WRA001	4035	Property Tax - Current Supplemental	86,864	56,934	84,528
111	8267	WRA001	4040	Property Tax - Prior Supplemental	2,680	3,475	2,628
111	8267	WRA001	4090	Other Property Taxes	225,620	208,840	221,197
111	8267	WRA001	4300	Other Licenses and Permits	44,283	42,634	44,283
111	8267	WRA001	4600	Investment Income	115,381	43,188	74,840
111	8267	WRA001	5030	Homeowners Property Tax Relief	10,717	10,700	10,669
111	8267	WRA001	5050	Other State Aid	242,000	100,000	39,926
111	8267	WRA001	5290	Federal Aid Other	-	623,750	-
111	8267	WRA001	5415	Special Assessments	1,145,102	1,199,766	1,133,765
111	8267	WRA001	5505	Planning and Engineering Services	-	-	5,513
111	8267	WRA001	5750	Other Services and Non-Taxable Sales	208,000	208,000	6,119
111	8267	WRA001	5855	Other Reimbursement	151,198	26,198	53,749
111	8267	WRA001	5870	Miscellaneous Revenues	-	-	686
111	8267	WRA001	5940	Operating Transfers In	-	-	2,500,000

EXPENDITURES:	6,578,556	5,374,265	5,048,628
REVENUES:	4,978,612	4,909,517	6,827,810

## FUND 112 - Pajaro Levee (Zone 1/1A)

## FY25 Budget Summary

### Revenues

Ad-Valorem Taxes	0
Special Assessments (Zone 1 & 1A)	556,319
San Luis Obispo County Payment	0
Grants	0
Federal Aid (FEMA, Etc)	
Lease & Interest Revenue	8,110
Development & Annexation Fees	0
Hydroelectric Revenue	0
Water Delivery & Service Fees	0
Other Revenues	309,168
Fund Transfer In	170,000
Debt Service Funds	0

**Total Revenues 1,043,597**

### Expenditures

Salaries & Benefits	84,307
General Liability & Pollution Insurances	22,569
County Cost Allocation Plan	5,447
Consultant (Non M1W)	20,000
Monterey One Water	0
Equipment	0
County Department Charges	95,218
Other Services Supplies	817,150
Fund Transfers Out	0
Debt Payments (CSIP, SVRP, SVWP)	0
Debt Service Funds	0

**Total Expenditures 1,044,691**

**Impact to Fund Balance (1,094)**

**Est. Beginning Fund Balance 270,334**

**Est. Ending Fund Balance 269,240**



# Fund 112 – Pajaro Levee - Zone 1 Boundary

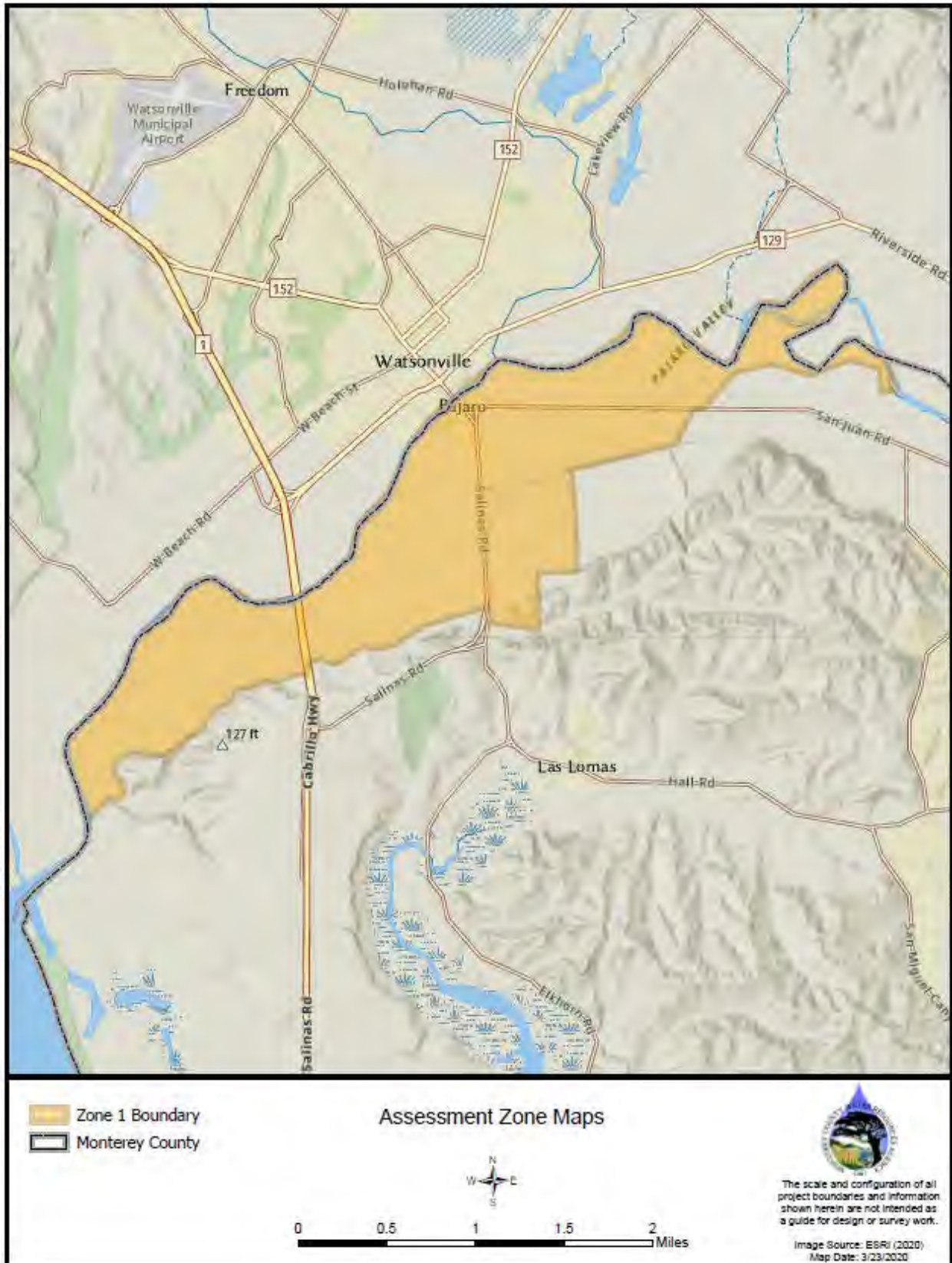

# Fund 112 – Pajaro Levee - Zone 1A Boundary

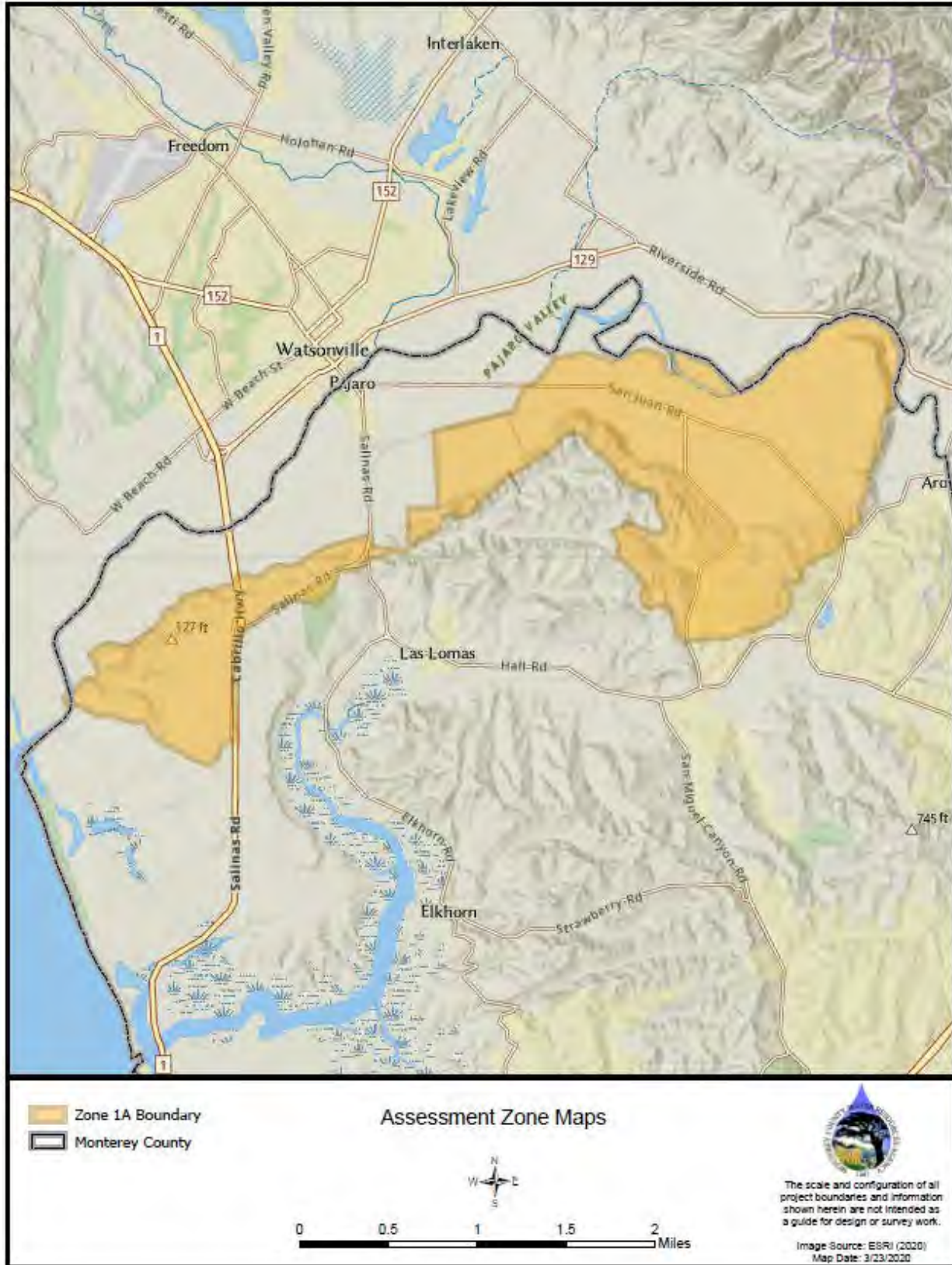

## Fund 112 - FY25 Budget Expenditure & Revenue Details

FUND	Unit	Appt	Budget Object	Budget Object Name	FY25 Recommended	FY24 Amended	FY23 Actual
112	8484	WRA002	6111	Regular Employees	40,663	167,381	184,115
112	8484	WRA002	6112	Temporary Employees	15,600	40,000	74,058
112	8484	WRA002	6113	Overtime	203	853	16,759
112	8484	WRA002	6121	PERS	7,491	41,989	42,524
112	8484	WRA002	6122	Other Post-Employment Benefits	-	498	-
112	8484	WRA002	6131	FICA	2,365	4,739	11,126
112	8484	WRA002	6132	Medicare	580	2,579	3,983
112	8484	WRA002	6141	Flex Co Paid Insurance-Pretax	889	3,168	2,828
112	8484	WRA002	6142	Life Insurance	37	96	138
112	8484	WRA002	6143	Long-Term Disability Insurance	25	168	208
112	8484	WRA002	6144	Short-Term Disability Insurance	31	192	219
112	8484	WRA002	6145	Dental Insurance	220	612	759
112	8484	WRA002	6147	Vision Insurance	67	144	241
112	8484	WRA002	6148	Unemployment Insurance	-	206	-
112	8484	WRA002	6161	Workers Compensation Insurance	8,057	5,651	6,465
112	8484	WRA002	6171	Employee Assistance Program	12	-	2
112	8484	WRA002	6173	Flex-Benefit Plan Contribution	7,871	38,244	30,829
112	8484	WRA002	6174	Special Benefits	170	663	943
112	8484	WRA002	6175	Wellness Plan	26	133	-
112	8484	WRA002	6222	Uniforms and Safety Equipment	-	-	929
112	8484	WRA002	6231	Communication Charges - External	303	-	-
112	8484	WRA002	6241	Food	-	-	116
112	8484	WRA002	6261	Insurance - General Liability (Non-recoverable)	5,654	17,558	16,463
112	8484	WRA002	6262	Insurance - General Liability (Recoverable)	727	1,272	1,100
112	8484	WRA002	6266	Insurance - Property	11,598	5,577	5,798
112	8484	WRA002	6268	Insurance - Other	4,590	13,947	12,376
112	8484	WRA002	6311	Bldg Improvements/Maintenance -External	250,000	649,000	802,830
112	8484	WRA002	6321	Equipment Maintenance	-	-	7,288
112	8484	WRA002	6361	Noncapital Equipment	1,056	-	-
112	8484	WRA002	6384	Miscellaneous Supplies	-	-	2,999
112	8484	WRA002	6401	Books/Periodicals & Subscriptions	1,584	-	-
112	8484	WRA002	6405	Courier Services - Internal	64	320	281
112	8484	WRA002	6406	Mail Handling Charges	4	37	28
112	8484	WRA002	6409	Minor Equipment and Furnishings	-	-	615
112	8484	WRA002	6411	Postage and Shipping	47	201	115
112	8484	WRA002	6415	Records Retention Charge - Internal	7	28	28
112	8484	WRA002	6603	Data Processing Services - Internal	2,821	36,400	8,320
112	8484	WRA002	6606	Legal Service - External	20,000	-	-
112	8484	WRA002	6607	Legal Service - Internal	92,275	13,318	20,675
112	8484	WRA002	6609	Other Personnel Services	-	-	4,547
112	8484	WRA002	6611	Staff Training Services	253	-	-
112	8484	WRA002	6613	Other Professional & Special Services	20,000	105,000	336,756
112	8484	WRA002	6821	Rents and Leases - Equipment	20,987	97,247	2,128
112	8484	WRA002	6835	Other Special Departmental Expenses	10,000	30,000	14,513
112	8484	WRA002	6861	Conference/Lodging/Meals/Travel	-	-	4
112	8484	WRA002	6864	Fleet Service Charge	2,353	-	3,668
112	8484	WRA002	6866	Vehicle Maintenance - External	1,006	-	3,732
112	8484	WRA002	6881	Utilities	-	-	3,849
112	8484	WRA002	7013	Reimbursement to Other Gvnmt Agency	10,000	10,000	10,000
112	8484	WRA002	7101	Rights Of Way	-	506,000	-
112	8484	WRA002	7121	Taxes and Assessments	800	700	682
112	8484	WRA002	7201	Contribution to Other Agency	494,778	1,376,548	-

## Fund 112- FY25 Budget Expenditure & Revenue Details

FUND	Unit	Appt	Budget Object	Budget Object Name	FY25 Recommended	FY24 Amended	FY23 Actual
112	8484	WRA002	7301	Cost Plan Charges	5,447	66,914	24,315
112	8484	WRA002	7533	Right-To-Use Expenditure - Equipment	598	2,725	-
112	8484	WRA002	7534	Right-to-Use Expenditure - Vehicles	3,432	-	1,711
112	8484	WRA002	7614	Operating Transfers Out	-	400,000	-
112	8484	WRA002	4010	Property Tax - Current Secured		32,333	31,090
112	8484	WRA002	4015	Property Tax - Current Unsecured		10,777	10,363
112	8484	WRA002	4025	Property Tax - Prior Secured		377	214
112	8484	WRA002	4030	Property Tax - Prior Unsecured		646	7
112	8484	WRA002	4035	Property Tax - Current Supplemental		35	-
112	8484	WRA002	4600	Investment Income	8,110	4,962	11,182
112	8484	WRA002	5050	Other State Aid	-	492,500	-
112	8484	WRA002	5415	Special Assessments	556,319	533,123	513,418
112	8484	WRA002	5855	Other Reimbursement	309,168	312,000	-
112	8484	WRA002	5940	Operating Transfers In	170,000	1,056,920	2,450,000

EXPENDITURES:	1,044,691	3,640,108	1,661,063
REVENUES:	1,043,597	2,443,673	3,016,274

## FUND 116 - Dam Operations (Zone 2C)

## FY25 Budget Summary

### Revenues

Ad-Valorem Taxes	0
Special Assessments (Zone 2C)	4,520,677
San Luis Obispo County Payment	614,070
Grants	6,524,900
Federal Aid (FEMA, Etc)	0
Lease & Interest Revenue	473,665
Development & Annexation Fees	0
Hydroelectric Revenue	0
Water Delivery & Service Fees	0
Other Revenues	155,933
Fund Transfer In	1,100,000
Debt Service Funds	0

<b>Total Revenues</b>	<b>13,389,245</b>
-----------------------	-------------------

### Expenditures

Salaries & Benefits	4,273,217
General Liability & Pollution Insurances	1,051,235
County Cost Allocation Plan	288,699
Consultant (Non M1W)	8,177,460
Monterey One Water	0
Equipment	0
County Department Charges	426,480
Other Services Supplies	1,378,371
Fund Transfers Out	105,000
Debt Payments (CSIP, SVRP, SVWP)	0
Debt Service Funds	0

<b>Total Expenditures</b>	<b>15,700,462</b>
---------------------------	-------------------

<b>Impact to Fund Balance</b>	<b>(2,311,217)</b>
-------------------------------	--------------------

<b>Est. Beginning Fund Balance</b>	<b>4,062,181</b>
------------------------------------	------------------

<b>Est. Ending Fund Balance</b>	<b>1,750,964</b>
---------------------------------	------------------



#### Authorized Fund Transfers:

- > Annual Assignment of \$105,000 to Fund 116-BSA 3123 for capital projects, to accumulated total amount of \$840,000
- > Receiving Transfer-in from County General Fund of \$1,100,000 for 2023 winter storm repair

# Fund 116 – Dam Operations - Zone 2C Boundary



## Fund 116 - FY25 Budget Expenditure & Revenue Details

FUND	Unit	Appt	Budget Object	Budget Object Name	FY25 Recommended	FY24 Amended	FY23 Actual
116	8485	WRA006	6111	Regular Employees	2,366,255	2,463,085	1,802,226
116	8485	WRA006	6112	Temporary Employees	105,200	101,370	91,451
116	8485	WRA006	6113	Overtime	8,764	17,167	35,144
116	8485	WRA006	6121	PERS	741,959	567,175	439,753
116	8485	WRA006	6122	Other Post-Employment Benefits	129	6,236	5,554
116	8485	WRA006	6131	FICA	194,630	53,731	84,606
116	8485	WRA006	6132	Medicare	47,440	37,401	27,963
116	8485	WRA006	6141	Flex Co Paid Insurance-Pretax	52,704	42,822	27,408
116	8485	WRA006	6142	Life Insurance	2,830	2,076	1,473
116	8485	WRA006	6143	Long-Term Disability Insurance	3,627	2,856	1,875
116	8485	WRA006	6144	Short-Term Disability Insurance	4,573	3,324	1,978
116	8485	WRA006	6145	Dental Insurance	13,178	10,548	7,582
116	8485	WRA006	6147	Vision Insurance	4,058	3,216	2,466
116	8485	WRA006	6148	Unemployment Insurance	1,372	2,578	1,136
116	8485	WRA006	6161	Workers Compensation Insurance	70,406	70,698	65,659
116	8485	WRA006	6171	Employee Assistance Program	691	-	26
116	8485	WRA006	6173	Flex-Benefit Plan Contribution	638,008	510,696	308,094
116	8485	WRA006	6174	Special Benefits	16,003	10,453	10,785
116	8485	WRA006	6175	Wellness Plan	1,390	1,659	-
116	8485	WRA006	6222	Uniforms and Safety Equipment	750	750	2,577
116	8485	WRA006	6231	Communication Charges - External	16,047	750	2,003
116	8485	WRA006	6241	Food	250	500	1,501
116	8485	WRA006	6261	Insurance - General Liability (Non-recoverable)	330,559	183,199	167,205
116	8485	WRA006	6262	Insurance - General Liability (Recoverable)	293,262	13,267	11,175
116	8485	WRA006	6266	Insurance - Property	101,349	58,182	58,885
116	8485	WRA006	6268	Insurance - Other	326,065	145,515	129,982
116	8485	WRA006	6311	Bldg Improvements/Maintenance -External	40,000	28,750	130,155
116	8485	WRA006	6312	Bldg Improvements/Maintenance -Internal	-	-	344
116	8485	WRA006	6321	Equipment Maintenance	40,000	68,700	57,916
116	8485	WRA006	6351	Membership Fees	14,469	10,275	235
116	8485	WRA006	6361	Noncapital Equipment	92,329	139,447	57,041
116	8485	WRA006	6381	Advertising	500	425	3,885
116	8485	WRA006	6384	Miscellaneous Supplies	4,000	7,500	11,671
116	8485	WRA006	6401	Books/Periodicals & Subscriptions	19,324	7,770	7,919
116	8485	WRA006	6402	Bottled Water	2,500	1,500	1,841
116	8485	WRA006	6404	Courier Services - External	500	500	343
116	8485	WRA006	6405	Courier Services - Internal	3,356	1,239	2,849
116	8485	WRA006	6406	Mail Handling Charges	193	141	297
116	8485	WRA006	6407	Minor Computer Hardware	8,000	6,500	274
116	8485	WRA006	6408	Minor Computer Software	6,600	6,568	6,568
116	8485	WRA006	6409	Minor Equipment and Furnishings	27,000	1,069	5,261
116	8485	WRA006	6410	Office Supplies	1,000	200	137
116	8485	WRA006	6411	Postage and Shipping	2,481	779	972
116	8485	WRA006	6412	Printing, Graphics & Binding- External	100	510	555
116	8485	WRA006	6414	Other Office Expense	5,050	41	43
116	8485	WRA006	6415	Records Retention Charge - Internal	362	109	289
116	8485	WRA006	6603	Data Processing Services - Internal	399,513	141,313	108,568
116	8485	WRA006	6605	Laboratory Services	30,000	6,087	4,728

## Fund 116 - FY25 Budget Expenditure & Revenue Details

FUND	Unit	Appt	Budget Object	Budget Object Name	FY25 Recommended	FY24 Amended	FY23 Actual
116	8485	WRA006	6606	Legal Service - External	10,000	10,000	-
116	8485	WRA006	6607	Legal Service - Internal	20,575	181,500	15,311
116	8485	WRA006	6609	Other Personnel Services	20,000	46,615	18,247
116	8485	WRA006	6611	Staff Training Services	13,408	2,500	4,932
116	8485	WRA006	6613	Other Professional & Special Services	8,177,460	7,363,507	2,796,930
116	8485	WRA006	6821	Rents and Leases - Equipment	52,279	20,368	93,396
116	8485	WRA006	6835	Other Special Departmental Expenses	322,277	308,058	306,930
116	8485	WRA006	6861	Conference/Lodging/Meals/Travel	59,000	3,700	1,287
116	8485	WRA006	6862	Employee Mileage Reimbursement	1,000	1,000	-
116	8485	WRA006	6864	Fleet Service Charge	55,142	40,340	37,249
116	8485	WRA006	6866	Vehicle Maintenance - External	23,572	3,740	23,225
116	8485	WRA006	6881	Utilities	48,000	25,760	52,735
116	8485	WRA006	7013	Reimbursement to Other Gvnmt Agency	284,130	205,428	77,653
116	8485	WRA006	7121	Taxes and Assessments	69,000	65,000	65,485
116	8485	WRA006	7301	Cost Plan Charges	288,699	837,154	246,952
116	8485	WRA006	7531	Equipment	-	-	30,936
116	8485	WRA006	7532	Vehicles	-	71,325	-
116	8485	WRA006	7533	Right-To-Use Expenditure - Equipment	31,687	34,088	-
116	8485	WRA006	7534	Right-to-Use Expenditure - Vehicles	80,457	60,623	35,077
116	8485	WRA006	7614	Operating Transfers Out	105,000	1,005,000	-
116	8485	WRA006	4300	Other Licenses and Permits	147,093	142,206	144,920
116	8485	WRA006	4600	Investment Income	148,865	24,340	69,696
116	8485	WRA006	4675	Rents, Concessions, and Leases	324,800	336,000	211,245
116	8485	WRA006	4750	Royalties	614,070	582,600	582,468
116	8485	WRA006	5050	Other State Aid	6,524,900	8,397,000	477,496
116	8485	WRA006	5290	Federal Aid Other		500,000	-
116	8485	WRA006	5415	Special Assessments	4,520,677	4,619,495	4,163,975
116	8485	WRA006	5750	Other Services and Non-Taxable Sales	8,840	6,581	12,629
116	8485	WRA006	5870	Miscellaneous Revenues		-	40
116	8485	WRA006	5940	Operating Transfers In	1,100,000	940,200	3,636,162

EXPENDITURES:	15,700,462	15,024,383	7,496,743
REVENUES:	13,389,245	15,548,422	9,298,631

## FUND 121 - Soledad Storm Drain (Zone 8)

## FY25 Budget Summary

### Revenues

Ad-Valorem Taxes	14,340
Special Assessments (Zone 8)	87,328
San Luis Obispo County Payment	0
Grants	0
Federal Aid (FEMA, Etc)	0
Lease & Interest Revenue	7,383
Development & Annexation Fees	0
Hydroelectric Revenue	0
Water Delivery & Service Fees	0
Other Revenues	0
Fund Transfer In	0
Debt Service Funds	0

**Total Revenues 109,051**

### Expenditures

Salaries & Benefits	58,653
General Liability & Pollution Insurances	6,044
County Cost Allocation Plan	4,430
Consultant (Non M1W)	10,000
Monterey One Water	0
Equipment	0
County Department Charges	4,244
Other Services Supplies	43,525
Fund Transfers Out	0
Debt Payments (CSIP, SVRP, SVWP)	0
Debt Service Funds	0

**Total Expenditures 126,896**

**Impact to Fund Balance (17,845)**

**Est. Beginning Fund Balance 246,109**

**Est. Ending Fund Balance 228,264**



# Fund 121 – Soledad Storm Drain - Zone 8 Boundary

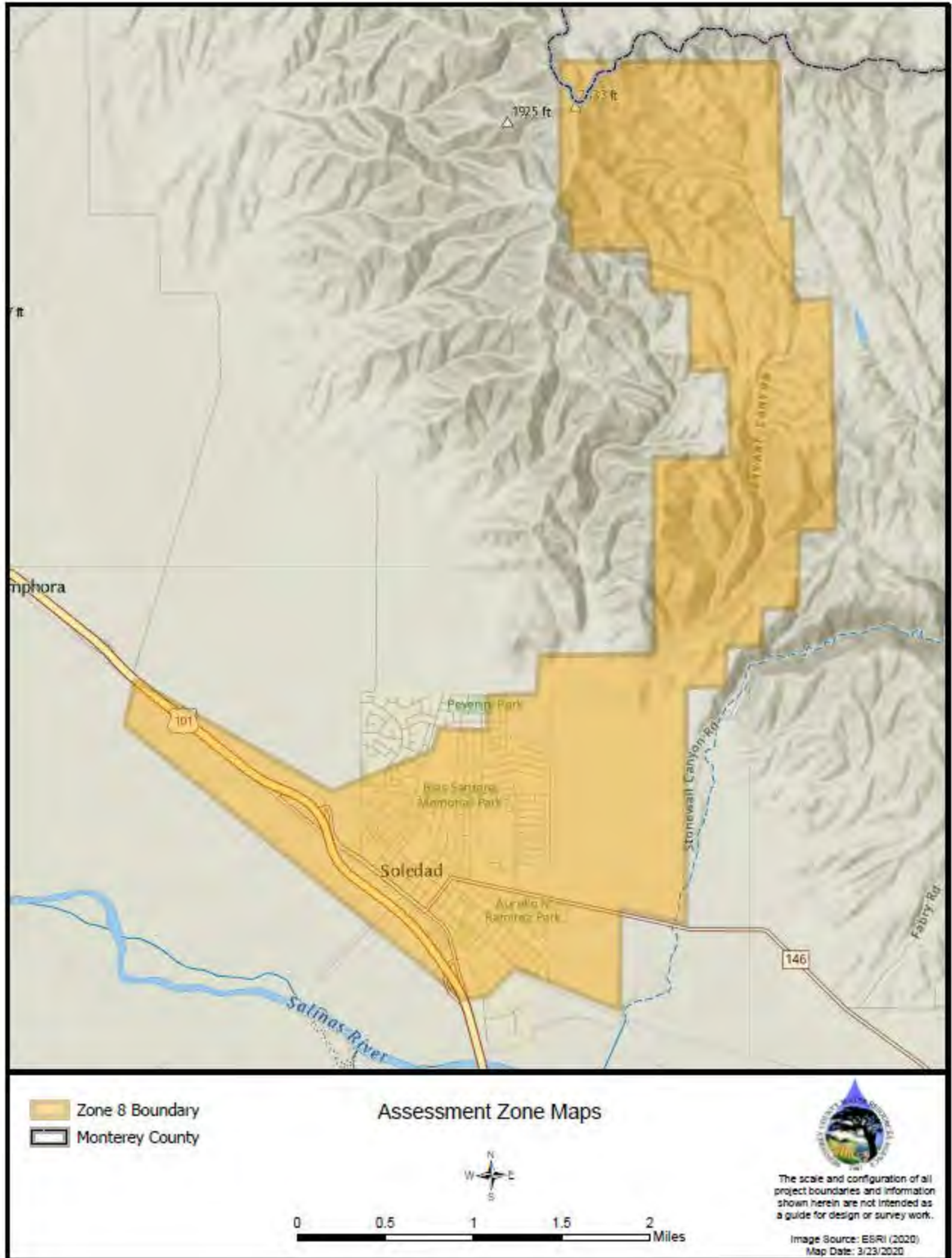

## Fund 121 - FY25 Budget Expenditure & Revenue Details

FUND	Unit	Appt	Budget Object	Budget Object Name	FY25 Recommended	FY24 Amended	FY23 Actual
121	8486	WRA011	6111	Regular Employees	37,838	56,875	19,742
121	8486	WRA011	6112	Temporary Employees	-	715	-
121	8486	WRA011	6113	Overtime	264	403	457
121	8486	WRA011	6121	PERS	7,018	12,815	4,033
121	8486	WRA011	6122	Other Post-Employment Benefits	-	172	-
121	8486	WRA011	6131	FICA	2,325	1,881	826
121	8486	WRA011	6132	Medicare	566	819	279
121	8486	WRA011	6141	Flex Co Paid Insurance-Pretax	739	1,122	329
121	8486	WRA011	6142	Life Insurance	37	12	16
121	8486	WRA011	6143	Long-Term Disability Insurance	41	12	16
121	8486	WRA011	6144	Short-Term Disability Insurance	52	36	16
121	8486	WRA011	6145	Dental Insurance	183	144	92
121	8486	WRA011	6147	Vision Insurance	56	48	29
121	8486	WRA011	6148	Unemployment Insurance	-	71	-
121	8486	WRA011	6161	Workers Compensation Insurance	652	1,945	1,730
121	8486	WRA011	6171	Employee Assistance Program	10	-	-
121	8486	WRA011	6173	Flex-Benefit Plan Contribution	8,644	11,808	4,041
121	8486	WRA011	6174	Special Benefits	207	263	221
121	8486	WRA011	6175	Wellness Plan	21	46	-
121	8486	WRA011	6231	Communication Charges - External	246	-	-
121	8486	WRA011	6261	Insurance - General Liability (Non-recoverable)	457	4,109	4,405
121	8486	WRA011	6262	Insurance - General Liability (Recoverable)	59	298	294
121	8486	WRA011	6266	Insurance - Property	938	1,305	1,551
121	8486	WRA011	6268	Insurance - Other	4,590	3,264	2,896
121	8486	WRA011	6311	Bldg Improvements/Maintenance -External	1,000	500	-
121	8486	WRA011	6351	Membership Fees	222	-	-
121	8486	WRA011	6361	Noncapital Equipment	-	1,500	-
121	8486	WRA011	6405	Courier Services - Internal	52	2,571	75
121	8486	WRA011	6406	Mail Handling Charges	3	3	8
121	8486	WRA011	6411	Postage and Shipping	39	12	25
121	8486	WRA011	6415	Records Retention Charge - Internal	6	2	8
121	8486	WRA011	6601	Accounting & Auditing Charges	-	60	-
121	8486	WRA011	6603	Data Processing Services - Internal	2,294	2,106	2,226
121	8486	WRA011	6607	Legal Service - Internal	1,850	-	-
121	8486	WRA011	6611	Staff Training Services	6,285	-	-
121	8486	WRA011	6613	Other Professional & Special Services	10,000	10,000	191
121	8486	WRA011	6821	Rents and Leases - Equipment	803	304	(856)
121	8486	WRA011	6835	Other Special Departmental Expenses	2,000	3,000	1,572
121	8486	WRA011	6861	Conference/Lodging/Meals/Travel	-	-	19
121	8486	WRA011	6864	Fleet Service Charge	11,253	1,282	981
121	8486	WRA011	6866	Vehicle Maintenance - External	4,811	235	436
121	8486	WRA011	7301	Cost Plan Charges	4,430	23,036	6,506
121	8486	WRA011	7532	Vehicles	-	2,265	-
121	8486	WRA011	7533	Right-To-Use Expenditure - Equipment	486	938	-
121	8486	WRA011	7534	Right-to-Use Expenditure - Vehicles	16,419	1,926	856
121	8486	WRA011	4010	Property Tax - Current Secured	13,741.0	14,010	13,472
121	8486	WRA011	4015	Property Tax - Current Unsecured	476.0	485	467
121	8486	WRA011	4025	Property Tax - Prior Secured	104.0	136	102
121	8486	WRA011	4030	Property Tax - Prior Unsecured	3.0	-	3
121	8486	WRA011	4035	Property Tax - Current Supplemental	16.0	431	16
121	8486	WRA011	4040	Property Tax - Prior Supplemental	-	16	-
121	8486	WRA011	4090	Other Property Taxes	-	3,606	-

## Fund 121 - FY25 Budget Expenditure & Revenue Details

FUND	Unit	Appt	Budget Object	Budget Object Name	FY25 Recommended	FY24 Amended	FY23 Actual
121	8486	WRA011	4600	Investment Income	7,383.0	1,916	4,805
121	8486	WRA011	5415	Special Assessments	87,328	85,835	80,594
121	8486	WRA011	5870	Miscellaneous Revenues		-	3,495

EXPENDITURES:	126,896	147,903	53,020
REVENUES:	109,051	106,435	102,954

## FUND 122 - Reclamation Ditch (Zone 9)

## FY25 Budget Summary

### Revenues

Ad-Valorem Taxes	350,570
Special Assessments (Zone 9)	1,414,898
San Luis Obispo County Payment	0
Grants	0
Federal Aid (FEMA, Etc)	0
Lease & Interest Revenue	38,585
Development & Annexation Fees	0
Hydroelectric Revenue	0
Water Delivery & Service Fees	0
Other Revenues	0
Fund Transfer In	244,474
Debt Service Funds	0

**Total Revenues** **2,048,527**

### Expenditures

Salaries & Benefits	957,966
General Liability & Pollution Insurances	100,157
County Cost Allocation Plan	74,824
Consultant (Non M1W)	273,000
Monterey One Water	0
Equipment	0
County Department Charges	61,657
Other Services Supplies	500,631
Fund Transfers Out	0
Debt Payments (CSIP, SVRP, SVWP)	0
Debt Service Funds	0

**Total Expenditures** **1,968,235**

**Impact to Fund Balance** **80,292**

**Est. Beginning Fund Balance** **1,286,178**

**Est. Ending Fund Balance** **1,366,470**



Authorized Fund Transfers:

> Receiving Fund Transfer of \$ \$244,474 from Fund 111 for 2023 winterstorm repair

# Fund 122 – Reclamation Ditch - Zone 9 Boundary

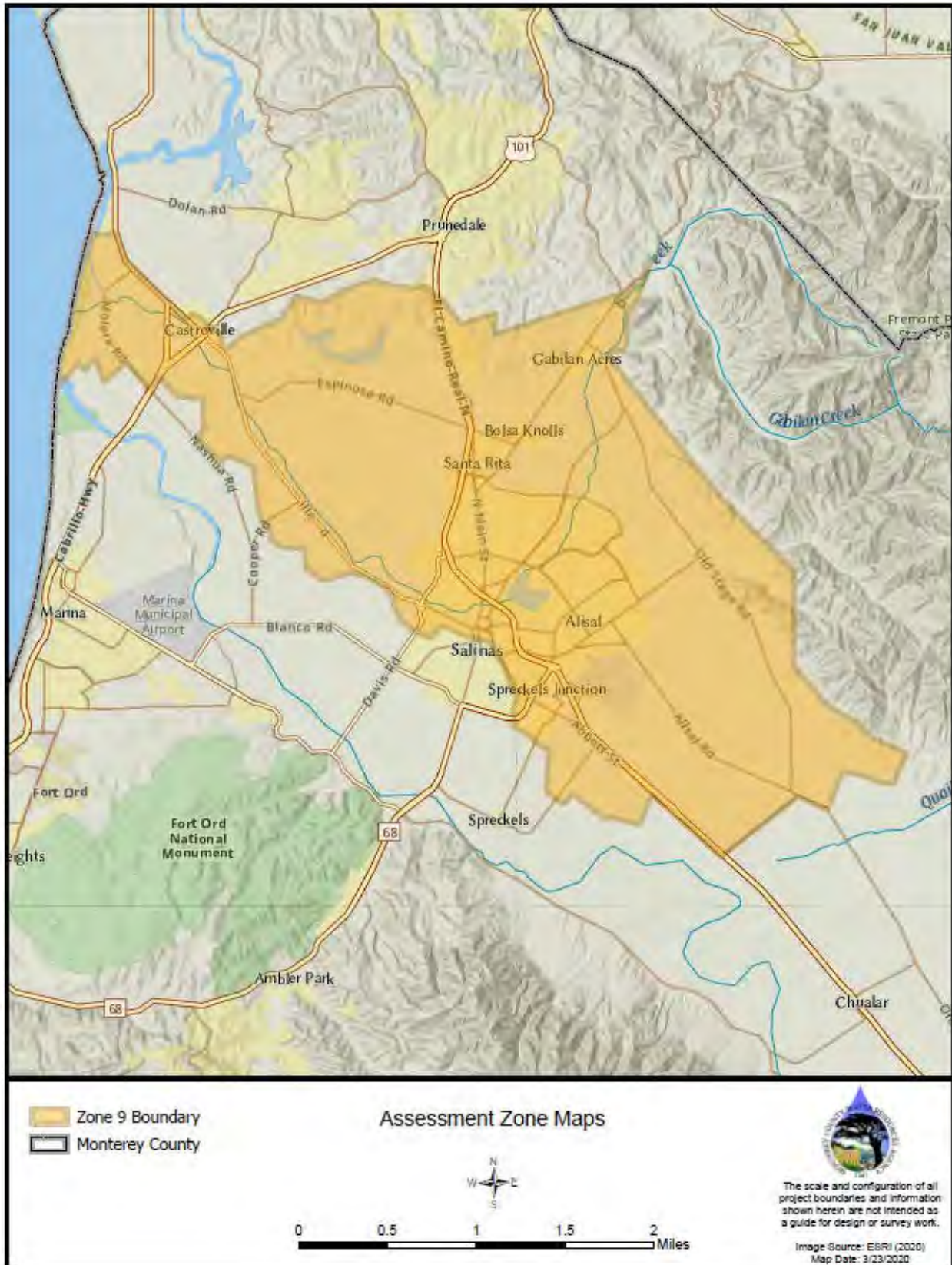

## Fund 122 - FY25 Budget Expenditure & Revenue Details

FUND	Unit	Appt	Budget Object	Budget Object Name	FY25 Recommended	FY24 Amended	FY23 Actual
122	8487	WRA012	6111	Regular Employees	585,206	473,590	459,667
122	8487	WRA012	6112	Temporary Employees	13,600	43,025	25,059
122	8487	WRA012	6113	Overtime	4,096	3,444	5,128
122	8487	WRA012	6121	PERS	146,045	151,344	124,361
122	8487	WRA012	6122	Other Post-Employment Benefits	95	1,373	4,273
122	8487	WRA012	6131	FICA	34,535	14,145	19,500
122	8487	WRA012	6132	Medicare	8,437	7,846	7,324
122	8487	WRA012	6141	Flex Co Paid Insurance-Pretax	12,376	10,104	8,818
122	8487	WRA012	6142	Life Insurance	547	432	456
122	8487	WRA012	6143	Long-Term Disability Insurance	489	540	475
122	8487	WRA012	6144	Short-Term Disability Insurance	617	672	500
122	8487	WRA012	6145	Dental Insurance	3,056	2,364	2,430
122	8487	WRA012	6147	Vision Insurance	929	696	806
122	8487	WRA012	6148	Unemployment Insurance	1,006	568	874
122	8487	WRA012	6161	Workers Compensation Insurance	11,672	15,563	21,124
122	8487	WRA012	6171	Employee Assistance Program	160	-	11
122	8487	WRA012	6173	Flex-Benefit Plan Contribution	131,910	117,336	91,533
122	8487	WRA012	6174	Special Benefits	2,830	2,218	6,258
122	8487	WRA012	6175	Wellness Plan	360	365	-
122	8487	WRA012	6222	Uniforms and Safety Equipment	7,908	8,102	8,823
122	8487	WRA012	6231	Communication Charges - External	4,159	-	-
122	8487	WRA012	6251	Cleaning and Janitorial	1,980	2,100	1,800
122	8487	WRA012	6261	Insurance - General Liability (Non-recoverable)	9,486	55,998	53,794
122	8487	WRA012	6262	Insurance - General Liability (Recoverable)	3,292	4,057	3,595
122	8487	WRA012	6266	Insurance - Property	16,801	17,786	18,945
122	8487	WRA012	6268	Insurance - Other	70,578	44,480	40,123
122	8487	WRA012	6311	Bldg Improvements/Maintenance -External	100,000	15,000	158,668
122	8487	WRA012	6321	Equipment Maintenance	90,631	456,650	81,869
122	8487	WRA012	6351	Membership Fees	3,750	-	200
122	8487	WRA012	6361	Noncapital Equipment	25,563	150,000	7,937
122	8487	WRA012	6381	Advertising	-	100	-
122	8487	WRA012	6384	Miscellaneous Supplies	3,500	9,000	4,142
122	8487	WRA012	6401	Books/Periodicals & Subscriptions	1,056	1,000	368
122	8487	WRA012	6402	Bottled Water	350	400	221
122	8487	WRA012	6405	Courier Services - Internal	870	480	917
122	8487	WRA012	6406	Mail Handling Charges	50	55	92
122	8487	WRA012	6407	Minor Computer Hardware	3,300	-	16
122	8487	WRA012	6408	Minor Computer Software	3,000	5,194	2,676
122	8487	WRA012	6409	Minor Equipment and Furnishings	10,000	10,000	225
122	8487	WRA012	6411	Postage and Shipping	643	302	307
122	8487	WRA012	6415	Records Retention Charge - Internal	94	43	93
122	8487	WRA012	6601	Accounting & Auditing Charges	-	735	-
122	8487	WRA012	6603	Data Processing Services - Internal	38,750	54,751	48,473
122	8487	WRA012	6606	Legal Service - External	-	-	(2,327)
122	8487	WRA012	6607	Legal Service - Internal	21,250	500	701
122	8487	WRA012	6609	Other Personnel Services	-	11,000	-
122	8487	WRA012	6611	Staff Training Services	18,885	15,000	3,669
122	8487	WRA012	6613	Other Professional & Special Services	273,000	485,435	46,901
122	8487	WRA012	6801	Publications and Legal Notices	610	7,000	-
122	8487	WRA012	6821	Rents and Leases - Equipment	13,550	11,810	106,868
122	8487	WRA012	6835	Other Special Departmental Expenses	45,958	38,450	36,367
122	8487	WRA012	6861	Conference/Lodging/Meals/Travel	2,000	1,500	115

## Fund 122 - FY25 Budget Expenditure & Revenue Details

FUND	Unit	Appt	Budget Object	Budget Object Name	FY25 Recommended	FY24 Amended	FY23 Actual
122	8487	WRA012	6862	Employee Mileage Reimbursement	500	500	-
122	8487	WRA012	6864	Fleet Service Charge	14,835	15,288	11,984
122	8487	WRA012	6866	Vehicle Maintenance - External	6,342	20,605	8,149
122	8487	WRA012	6881	Utilities	95,506	73,920	106,739
122	8487	WRA012	7013	Reimbursement to Other Gvnmt Agency	17,390	43,714	8,698
122	8487	WRA012	7301	Cost Plan Charges	74,824	184,287	79,451
122	8487	WRA012	7531	Equipment	-	-	196,897
122	8487	WRA012	7532	Vehicles	-	27,030	59,877
122	8487	WRA012	7533	Right-To-Use Expenditure - Equipment	8,213	7,504	-
122	8487	WRA012	7534	Right-to-Use Expenditure - Vehicles	21,645	22,975	11,977
122	8487	WRA012	4010	Property Tax - Current Secured	329,797	323,331	310,896
122	8487	WRA012	4015	Property Tax - Current Unsecured	13,191	12,933	12,436
122	8487	WRA012	4025	Property Tax - Prior Secured	4,396	4,310	2,611
122	8487	WRA012	4030	Property Tax - Prior Unsecured	-	-	89
122	8487	WRA012	4035	Property Tax - Current Supplemental	2,747	2,694	415
122	8487	WRA012	4040	Property Tax - Prior Supplemental	439	431	-
122	8487	WRA012	4600	Investment Income	38,585	7,731	26,006
122	8487	WRA012	5050	Other State Aid	-	123,000	16,120
122	8487	WRA012	5290	Federal Aid Other	-	414,000	-
122	8487	WRA012	5415	Special Assessments	1,414,898	1,362,456	1,305,787
122	8487	WRA012	5855	Other Reimbursement	-	-	31,925
122	8487	WRA012	5870	Miscellaneous Revenues	-	-	359
122	8487	WRA012	5940	Operating Transfers In	244,474	400,000	-

EXPENDITURES:	1,968,235	2,648,376	1,887,947
REVENUES:	2,048,527	2,650,886	1,706,644

## FUND 124 - San Lorenzo Creek (Zone 12)

## FY25 Budget Summary

### Revenues

Ad-Valorem Taxes	9,736
Special Assessments (Zone 12)	36,467
San Luis Obispo County Payment	0
Grants	0
Federal Aid (FEMA, Etc)	
Lease & Interest Revenue	821
Development & Annexation Fees	0
Hydroelectric Revenue	0
Water Delivery & Service Fees	0
Other Revenues	
Fund Transfer In	200,000
Debt Service Funds	0
<b>Total Revenues</b>	<b>247,024</b>

### Expenditures

Salaries & Benefits	33,752
General Liability & Pollution Insurances	3,196
County Cost Allocation Plan	2,514
Consultant (Non M1W)	202,000
Monterey One Water	0
Equipment	0
County Department Charges	2,410
Other Services Supplies	10,551
Fund Transfers Out	0
Debt Payments (CSIP, SVRP, SVWP)	0
Debt Service Funds	0
<b>Total Expenditures</b>	<b>254,423</b>

**Impact to Fund Balance (7,399)**

**Est. Beginning Fund Balance 27,375**

**Est. Ending Fund Balance 19,976**

Authorized Fund Transfers:

> Receiving Fund Transfer of \$ \$200,000 from Fund 111 for 2023 winterstorm repair



# Fund 124 – San Lorenzo Creek - Zone 12 Boundary

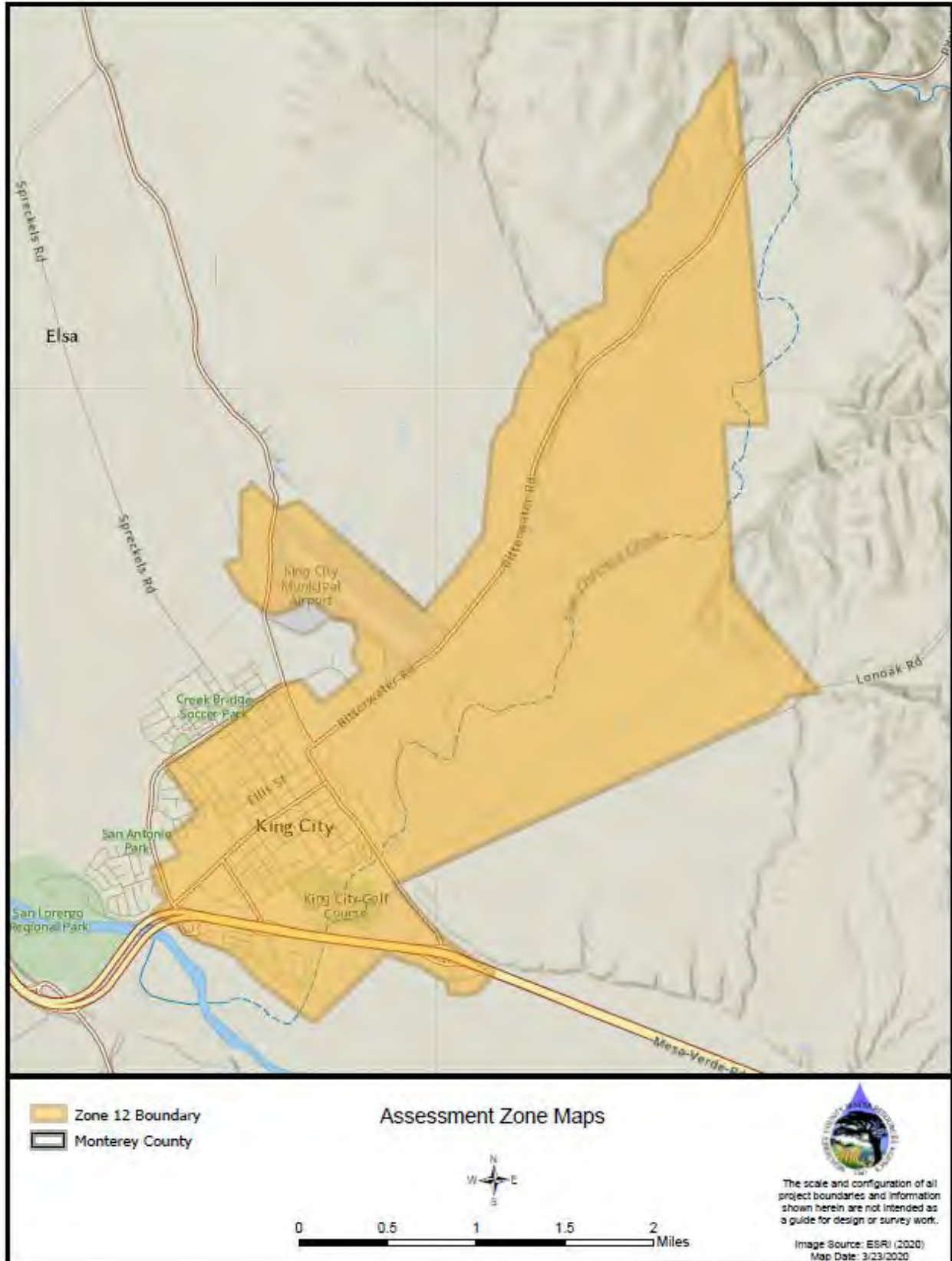

## Fund 124 - FY25 Budget Expenditure & Revenue Details

FUND	Unit	Appt	Budget Object	Budget Object Name	FY25 Recommended	FY24 Amended	FY23 Actual
124	8488	WRA014	6111	Regular Employees	22,282	16,632	10,608
124	8488	WRA014	6113	Overtime	155	122	107
124	8488	WRA014	6121	PERS	3,589	3,714	2,384
124	8488	WRA014	6122	Other Post-Employment Benefits	-	46	-
124	8488	WRA014	6131	FICA	1,349	435	519
124	8488	WRA014	6132	Medicare	328	236	156
124	8488	WRA014	6141	Flex Co Paid Insurance-Pretax	426	372	169
124	8488	WRA014	6142	Life Insurance	21	-	8
124	8488	WRA014	6143	Long-Term Disability Insurance	27	-	11
124	8488	WRA014	6144	Short-Term Disability Insurance	35	12	11
124	8488	WRA014	6145	Dental Insurance	105	24	47
124	8488	WRA014	6147	Vision Insurance	31	-	16
124	8488	WRA014	6148	Unemployment Insurance	-	19	-
124	8488	WRA014	6161	Workers Compensation Insurance	227	525	821
124	8488	WRA014	6171	Employee Assistance Program	5	-	-
124	8488	WRA014	6173	Flex-Benefit Plan Contribution	5,027	2,904	1,880
124	8488	WRA014	6174	Special Benefits	133	81	100
124	8488	WRA014	6175	Wellness Plan	12	12	-
124	8488	WRA014	6231	Communication Charges - External	140	-	-
124	8488	WRA014	6261	Insurance - General Liability (Non-recoverable)	159	2,055	2,090
124	8488	WRA014	6262	Insurance - General Liability (Recoverable)	20	149	140
124	8488	WRA014	6266	Insurance - Property	326	653	736
124	8488	WRA014	6268	Insurance - Other	2,691	1,632	1,448
124	8488	WRA014	6311	Bldg Improvements/Maintenance -External	1,000	-	1
124	8488	WRA014	6321	Equipment Maintenance	3,341	3,341	-
124	8488	WRA014	6351	Membership Fees	126	-	-
124	8488	WRA014	6361	Noncapital Equipment	200	200	239
124	8488	WRA014	6384	Miscellaneous Supplies	-	-	89
124	8488	WRA014	6401	Books/Periodicals & Subscriptions	500	500	308
124	8488	WRA014	6405	Courier Services - Internal	30	18	36
124	8488	WRA014	6406	Mail Handling Charges	2	2	4
124	8488	WRA014	6409	Minor Equipment and Furnishings	500	-	138
124	8488	WRA014	6411	Postage and Shipping	22	11	12
124	8488	WRA014	6415	Records Retention Charge - Internal	4	2	4
124	8488	WRA014	6601	Accounting & Auditing Charges	-	30	-
124	8488	WRA014	6603	Data Processing Services - Internal	1,302	1,956	1,057
124	8488	WRA014	6607	Legal Service - Internal	1,050	-	-
124	8488	WRA014	6611	Staff Training Services	117	-	-
124	8488	WRA014	6613	Other Professional & Special Services	202,000	1,000	13,484
124	8488	WRA014	6801	Publications and Legal Notices	620	-	-
124	8488	WRA014	6821	Rents and Leases - Equipment	456	282	(856)
124	8488	WRA014	6835	Other Special Departmental Expenses	1,500	-	746
124	8488	WRA014	6861	Conference/Lodging/Meals/Travel	-	-	4
124	8488	WRA014	6864	Fleet Service Charge	722	425	466
124	8488	WRA014	6866	Vehicle Maintenance - External	-	119	219
124	8488	WRA014	7013	Reimbursement to Other Gvnmt Agency	-	6,902	4,349
124	8488	WRA014	7301	Cost Plan Charges	2,514	6,216	3,088
124	8488	WRA014	7533	Right-To-Use Expenditure - Equipment	276	253	-
124	8488	WRA014	7534	Right-to-Use Expenditure - Vehicles	1,053	638	856
124	8488	WRA014	4010	Property Tax - Current Secured	9,513	9,700	9,327
124	8488	WRA014	4015	Property Tax - Current Unsecured	-	323	-
124	8488	WRA014	4025	Property Tax - Prior Secured	57	38	56

## Fund 124 - FY25 Budget Expenditure & Revenue Details

FUND	Unit	Appt	Budget Object	Budget Object Name	FY25 Recommended	FY24 Amended	FY23 Actual
124	8488	WRA014	4030	Property Tax - Prior Unsecured	2	-	2
124	8488	WRA014	4035	Property Tax - Current Supplemental	159	162	156
124	8488	WRA014	4040	Property Tax - Prior Supplemental	5	5	5
124	8488	WRA014	4090	Other Property Taxes	-	1,557	-
124	8488	WRA014	4600	Investment Income	821	376	594
124	8488	WRA014	5415	Special Assessments	36,467	35,088	33,655
124	8488	WRA014	5870	Miscellaneous Revenues	-	-	2
124	8488	WRA014	5940	Operating Transfers In	200,000	-	-

EXPENDITURES:	254,423	51,518	45,495
REVENUES:	247,024	47,249	43,797

## FUND 127 - Moro Cojo Slough (Zone 17)

## FY25 Budget Summary

### Revenues

Ad-Valorem Taxes	0
Special Assessments (Zone 17)	104,972
San Luis Obispo County Payment	0
Grants	0
Federal Aid (FEMA, Etc)	0
Lease & Interest Revenue	17,901
Development & Annexation Fees	0
Hydroelectric Revenue	0
Water Delivery & Service Fees	0
Other Revenues	0
Fund Transfer In	200,000
Debt Service Funds	0

<b>Total Revenues</b>	<b>322,873</b>
-----------------------	----------------

### Expenditures

Salaries & Benefits	74,454
General Liability & Pollution Insurances	10,513
County Cost Allocation Plan	4,011
Consultant (Non M1W)	467,848
Monterey One Water	0
Equipment	0
County Department Charges	3,843
Other Services Supplies	21,882
Fund Transfers Out	0
Debt Payments (CSIP, SVRP, SVWP)	0
Debt Service Funds	0

<b>Total Expenditures</b>	<b>582,551</b>
---------------------------	----------------

<b>Impact to Fund Balance</b>	<b>(259,678)</b>
-------------------------------	------------------

<b>Est. Beginning Fund Balance</b>	<b>596,684</b>
------------------------------------	----------------

<b>Est. Ending Fund Balance</b>	<b>337,006</b>
---------------------------------	----------------



Authorized Fund Transfers:

- > Receiving Fund Transfer of 50% of tidegate construction cost from Public Works Department

# Fund 127 – Moro Cojo Slough - Zone 17 Boundary

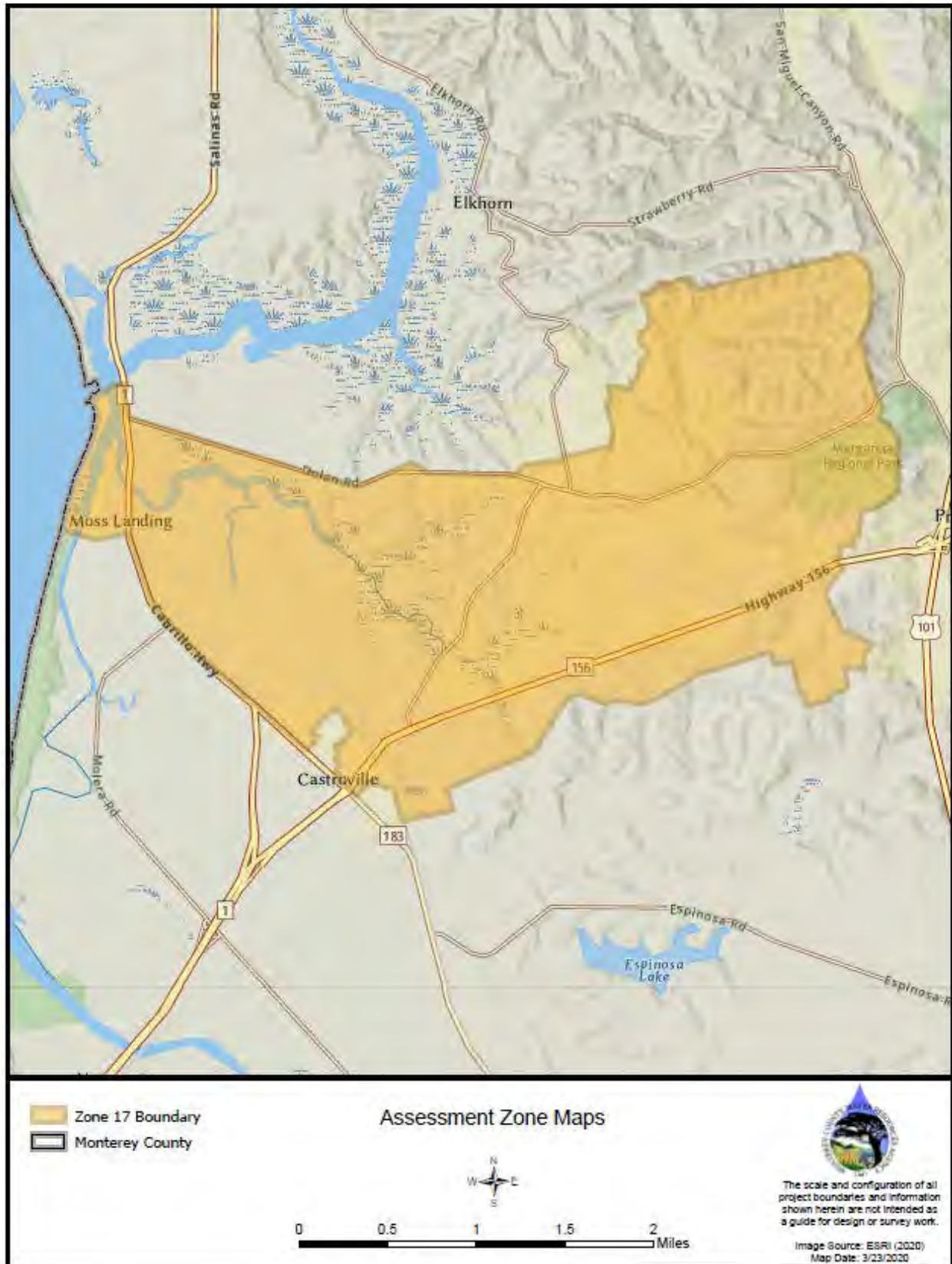

## Fund 127 - FY25 Budget Expenditure & Revenue Details

FUND	Unit	Appt	Budget Object	Budget Object Name	FY25 Recommended	FY24 Amended	FY23 Actual
127	8489	WRA017	6111	Regular Employees	38,204	63,771	26,707
127	8489	WRA017	6112	Temporary Employees	17,800	-	1,870
127	8489	WRA017	6113	Overtime	267	470	626
127	8489	WRA017	6121	PERS	2,961	13,396	4,430
127	8489	WRA017	6122	Other Post-Employment Benefits	-	176	-
127	8489	WRA017	6131	FICA	2,458	2,770	1,415
127	8489	WRA017	6132	Medicare	594	907	412
127	8489	WRA017	6141	Flex Co Paid Insurance-Pretax	647	1,074	394
127	8489	WRA017	6142	Life Insurance	37	24	23
127	8489	WRA017	6143	Long-Term Disability Insurance	53	36	39
127	8489	WRA017	6144	Short-Term Disability Insurance	67	36	41
127	8489	WRA017	6145	Dental Insurance	159	144	112
127	8489	WRA017	6147	Vision Insurance	48	36	37
127	8489	WRA017	6148	Unemployment Insurance	-	73	-
127	8489	WRA017	6161	Workers Compensation Insurance	2,690	1,992	1,686
127	8489	WRA017	6171	Employee Assistance Program	9	-	1
127	8489	WRA017	6173	Flex-Benefit Plan Contribution	8,201	12,000	5,005
127	8489	WRA017	6174	Special Benefits	240	279	213
127	8489	WRA017	6175	Wellness Plan	19	47	-
127	8489	WRA017	6231	Communication Charges - External	223	-	-
127	8489	WRA017	6261	Insurance - General Liability (Non-recoverable)	1,888	4,353	4,293
127	8489	WRA017	6262	Insurance - General Liability (Recoverable)	243	316	287
127	8489	WRA017	6266	Insurance - Property	3,872	1,383	1,512
127	8489	WRA017	6268	Insurance - Other	4,510	3,458	3,068
127	8489	WRA017	6311	Bldg Improvements/Maintenance -External	5,925	5,925	5,575
127	8489	WRA017	6321	Equipment Maintenance	4,750	4,750	830
127	8489	WRA017	6351	Membership Fees	201	-	-
127	8489	WRA017	6405	Courier Services - Internal	47	20	73
127	8489	WRA017	6406	Mail Handling Charges	3	3	7
127	8489	WRA017	6411	Postage and Shipping	35	13	24
127	8489	WRA017	6415	Records Retention Charge - Internal	6	2	7
127	8489	WRA017	6601	Accounting & Auditing Charges	59	59	-
127	8489	WRA017	6603	Data Processing Services - Internal	2,077	2,257	2,170
127	8489	WRA017	6607	Legal Service - Internal	1,675	-	-
127	8489	WRA017	6611	Staff Training Services	6,285	-	-
127	8489	WRA017	6613	Other Professional & Special Services	467,848	453,913	6,540
127	8489	WRA017	6801	Publications and Legal Notices	-	445	-
127	8489	WRA017	6821	Rents and Leases - Equipment	727	326	(856)
127	8489	WRA017	6835	Other Special Departmental Expenses	1,921	6,750	1,601
127	8489	WRA017	6861	Conference/Lodging/Meals/Travel	-	-	4
127	8489	WRA017	6864	Fleet Service Charge	468	1,010	956
127	8489	WRA017	6866	Vehicle Maintenance - External	200	346	268
127	8489	WRA017	6881	Utilities	-	-	10,669
127	8489	WRA017	7301	Cost Plan Charges	4,011	23,584	6,341
127	8489	WRA017	7532	Vehicles	-	1,785	-
127	8489	WRA017	7533	Right-To-Use Expenditure - Equipment	440	960	-
127	8489	WRA017	7534	Right-to-Use Expenditure - Vehicles	683	1,518	856
127	8489	WRA017	4600	Investment Income	17,901	4,988	11,176
127	8489	WRA017	5415	Special Assessments	104,972	99,506	96,877
127	8489	WRA017	5870	Miscellaneous Revenues	-	-	3,495
127	8489	WRA017	5940	Operating Transfers In	200,000	136,173	-

## Fund 127 - FY25 Budget Expenditure & Revenue Details

FUND	Unit	Appt	Budget Object	Budget Object Name	FY25 Recommended	FY24 Amended	FY23 Actual
EXPENDITURES:					582,551	610,407	87,236
REVENUES:					322,873	240,667	111,548

## FUND 130 - Hydroplant Operations

## FY25 Budget Summary

### Revenues

Ad-Valorem Taxes	0
Special Assessments	0
San Luis Obispo County Payment	0
Grants	0
Federal Aid (FEMA, Etc)	0
Lease & Interest Revenue	36,766
Development & Annexation Fees	0
Hydroelectric Revenue	1,140,961
Water Delivery & Service Fees	0
Other Revenues	0
Fund Transfer In	0
Debt Service Funds	0

**Total Revenues 1,177,727**

### Expenditures

Salaries & Benefits	304,256
General Liability & Pollution Insurances	32,984
County Cost Allocation Plan	20,651
Consultant (Non M1W)	265,000
Monterey One Water	0
Equipment	0
County Department Charges	19,779
Other Services Supplies	141,754
Fund Transfers Out	350,000
Debt Payments (CSIP, SVRP, SVWP)	
Debt Service Funds	0

**Total Expenditures 1,134,424**

**Impact to Fund Balance 43,303**

**Est. Beginning Fund Balance 1,225,558**

**Est. Ending Fund Balance 1,268,861**

Authorized Fund Transfers:

> Fund Transfer of \$350,000 to Fund 426 Interlake Tunnel Project



## Fund 130 - FY25 Budget Expenditure & Revenue Details

FUND	Unit	Appt	Budget Object	Budget Object Name	FY25 Recommended	FY24 Amended	FY23 Actual
130	8490	WRA022	6111	Regular Employees	196,543	231,517	159,471
130	8490	WRA022	6112	Temporary Employees	-	197	-
130	8490	WRA022	6113	Overtime	1,375	4,142	5,015
130	8490	WRA022	6121	PERS	43,997	49,373	37,734
130	8490	WRA022	6122	Other Post-Employment Benefits	9	613	427
130	8490	WRA022	6131	FICA	11,565	4,523	8,521
130	8490	WRA022	6132	Medicare	2,805	3,369	2,374
130	8490	WRA022	6141	Flex Co Paid Insurance-Pretax	3,506	4,062	2,470
130	8490	WRA022	6142	Life Insurance	172	216	127
130	8490	WRA022	6143	Long-Term Disability Insurance	208	216	159
130	8490	WRA022	6144	Short-Term Disability Insurance	262	252	168
130	8490	WRA022	6145	Dental Insurance	865	1,068	681
130	8490	WRA022	6147	Vision Insurance	263	384	220
130	8490	WRA022	6148	Unemployment Insurance	91	253	87
130	8490	WRA022	6161	Workers Compensation Insurance	4,300	6,948	6,465
130	8490	WRA022	6171	Employee Assistance Program	44	-	3
130	8490	WRA022	6173	Flex-Benefit Plan Contribution	37,131	41,484	23,446
130	8490	WRA022	6174	Special Benefits	1,021	867	1,073
130	8490	WRA022	6175	Wellness Plan	99	163	-
130	8490	WRA022	6222	Uniforms and Safety Equipment	200	-	41
130	8490	WRA022	6231	Communication Charges - External	1,148	5,445	4,895
130	8490	WRA022	6261	Insurance - General Liability (Non-recoverable)	3,266	17,411	16,463
130	8490	WRA022	6262	Insurance - General Liability (Recoverable)	818	1,262	1,100
130	8490	WRA022	6266	Insurance - Property	6,191	5,530	5,798
130	8490	WRA022	6268	Insurance - Other	22,709	13,830	12,337
130	8490	WRA022	6311	Bldg Improvements/Maintenance -External	10,000	10,000	15,373
130	8490	WRA022	6321	Equipment Maintenance	1,500	10,860	22,988
130	8490	WRA022	6351	Membership Fees	1,035	-	-
130	8490	WRA022	6361	Noncapital Equipment	7,000	2,000	8,793
130	8490	WRA022	6384	Miscellaneous Supplies	1,000	-	676
130	8490	WRA022	6401	Books/Periodicals & Subscriptions	100	-	33
130	8490	WRA022	6404	Courier Services - External	200	200	-
130	8490	WRA022	6405	Courier Services - Internal	241	194	281
130	8490	WRA022	6406	Mail Handling Charges	14	22	28
130	8490	WRA022	6408	Minor Computer Software	-	10,000	-
130	8490	WRA022	6409	Minor Equipment and Furnishings	1,000	-	1,567
130	8490	WRA022	6410	Office Supplies	300	400	-
130	8490	WRA022	6411	Postage and Shipping	178	122	94
130	8490	WRA022	6412	Printing, Graphics & Binding- External	-	-	25
130	8490	WRA022	6415	Records Retention Charge - Internal	26	17	28
130	8490	WRA022	6601	Accounting & Auditing Charges	-	225	-
130	8490	WRA022	6603	Data Processing Services - Internal	10,695	22,036	10,721
130	8490	WRA022	6607	Legal Service - Internal	8,625	621	314
130	8490	WRA022	6609	Other Personnel Services	2,000	2,000	-
130	8490	WRA022	6611	Staff Training Services	19,285	-	2,149
130	8490	WRA022	6613	Other Professional & Special Services	265,000	187,726	134,565
130	8490	WRA022	6821	Rents and Leases - Equipment	3,740	3,176	950
130	8490	WRA022	6835	Other Special Departmental Expenses	30,000	-	26,064
130	8490	WRA022	6861	Conference/Lodging/Meals/Travel	7,000	10,000	1,018
130	8490	WRA022	6862	Employee Mileage Reimbursement	250	-	-
130	8490	WRA022	6864	Fleet Service Charge	3,328	3,343	3,668
130	8490	WRA022	6866	Vehicle Maintenance - External	1,423	4,570	1,137

## Fund 130 - FY25 Budget Expenditure & Revenue Details

FUND	Unit	Appt	Budget Object	Budget Object Name	FY25 Recommended	FY24 Amended	FY23 Actual
130	8490	WRA022	6881	Utilities	44,122	43,534	36,769
130	8490	WRA022	7301	Cost Plan Charges	20,651	82,271	24,315
130	8490	WRA022	7532	Vehicles	-	5,910	-
130	8490	WRA022	7533	Right-To-Use Expenditure - Equipment	2,267	3,350	-
130	8490	WRA022	7534	Right-to-Use Expenditure - Vehicles	4,856	5,024	3,422
130	8490	WRA022	7614	Operating Transfers Out	350,000	175,000	121,162
130	8490	WRA022	4600	Investment Income	36,766	16,800	23,125
130	8490	WRA022	5750	Other Services and Non-Taxable Sales	1,140,961	772,856	636,281

EXPENDITURES:	1,134,424	975,726	705,215
REVENUES:	1,177,727	789,656	659,406

## FUND 131 - CSIP Operations (Zone 2B, 2Y)

## FY25 Budget Summary

### Revenues

Ad-Valorem Taxes	0
Special Assessments (Zone 2Y & 77% 2B )	4,770,388
San Luis Obispo County Payment	0
Grants	205,000
Federal Aid (FEMA, Etc)	900,000
Lease & Interest Revenue	86,165
Development & Annexation Fees	0
Hydroelectric Revenue	0
Water Delivery & Service Fees	224,808
Other Revenues	
Fund Transfer In	
Debt Service Funds	0

**Total Revenues 6,186,361**

### Expenditures

Salaries & Benefits	543,639
General Liability & Pollution Insurances	194,310
County Cost Allocation Plan	34,718
Consultant (Non M1W)	2,100,000
Monterey One Water	2,780,599
Equipment	0
County Department Charges	33,251
Other Services Supplies	77,961
Fund Transfers Out	0
Debt Payments (CSIP, SVRP, SVWP)	1,668,000
Debt Service Funds	0

**Total Expenditures 7,432,478**

**Impact to Fund Balance (1,246,117)**

**Est. Beginning Fund Balance 2,872,197**

**Est. Ending Fund Balance 1,626,080**



# Fund 131 – CSIP Operations - Zone 2Y Boundary

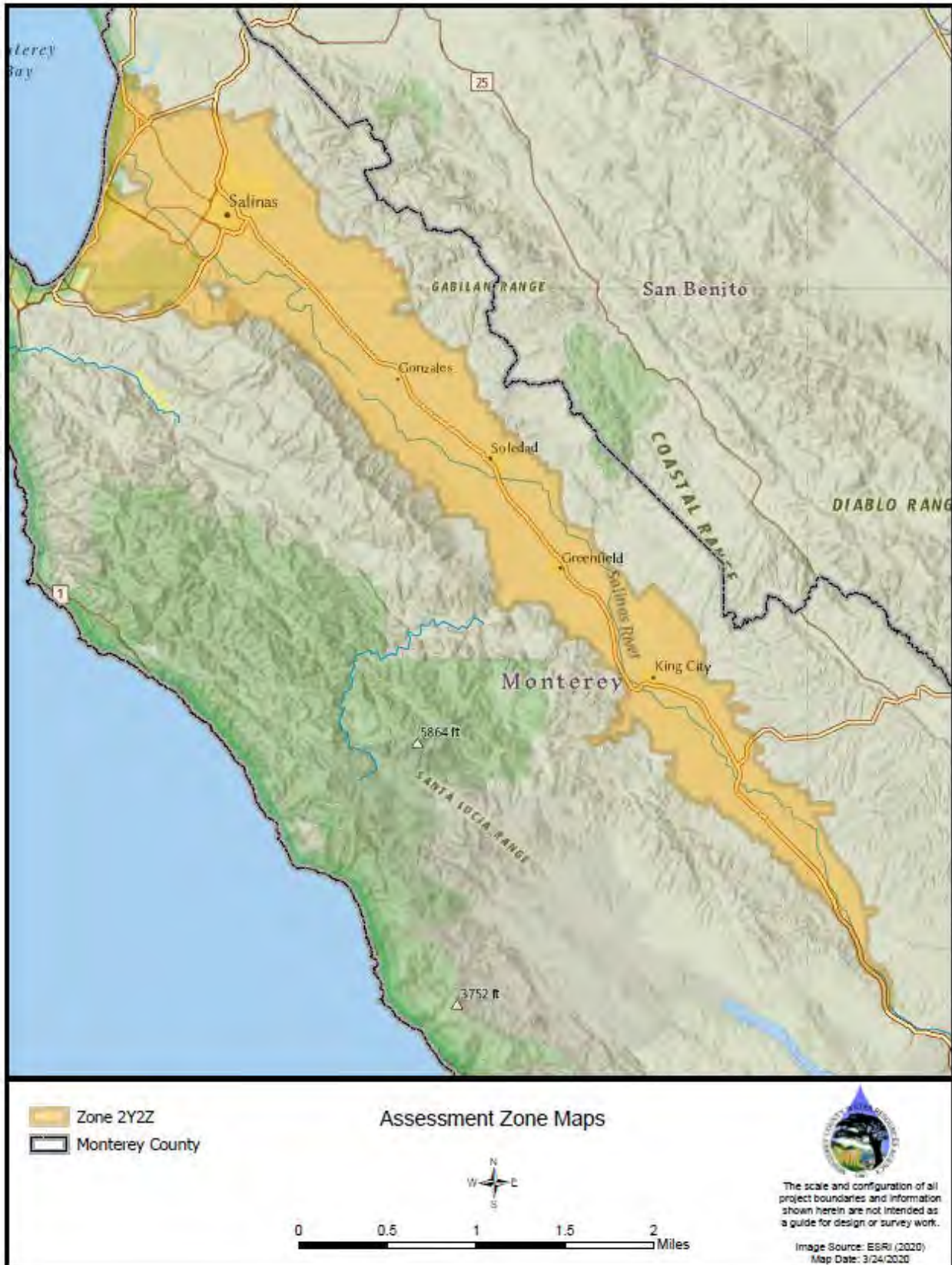

# Fund 131 & 132 - Zone 2B Boundary

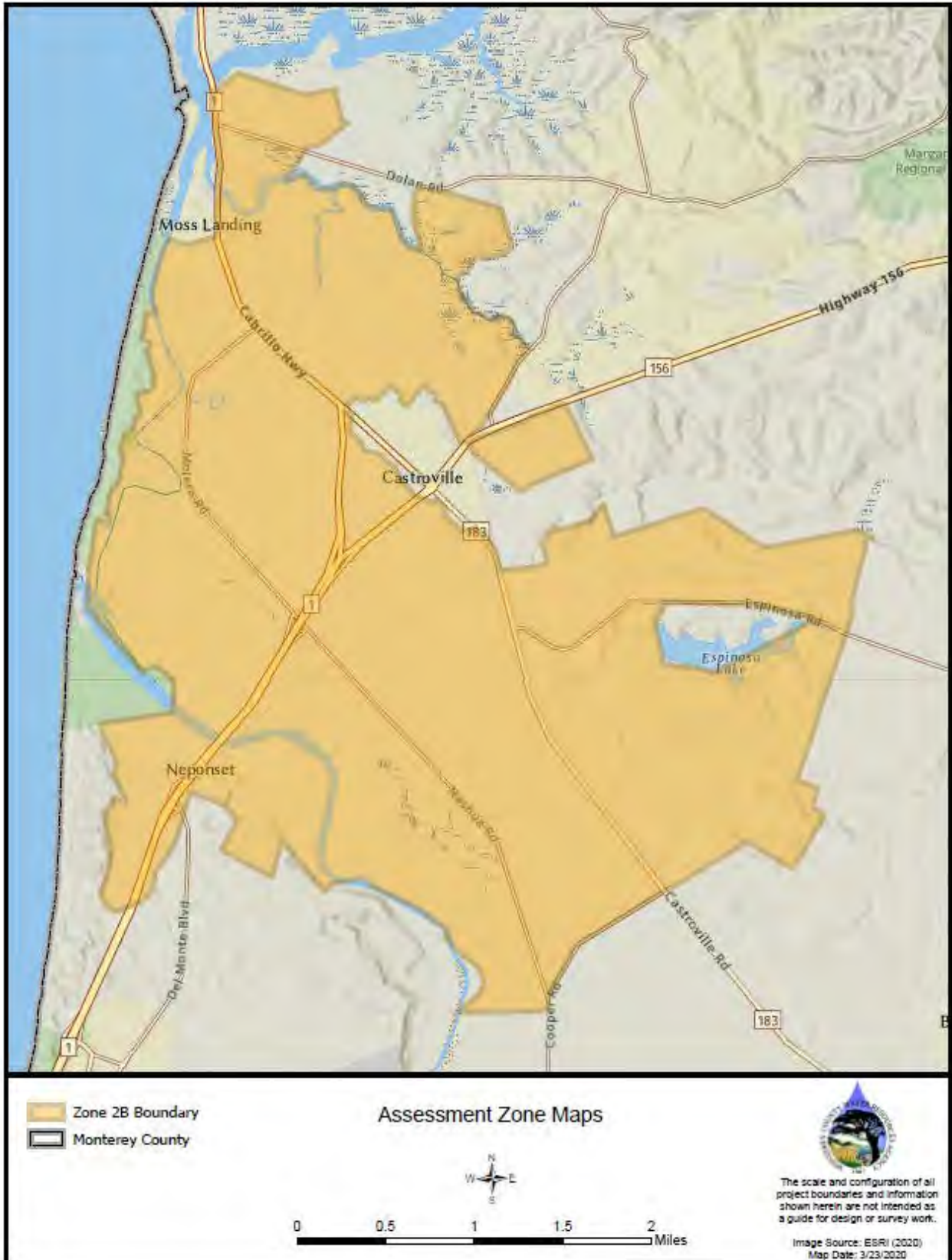

## Fund 131 - FY25 Budget Expenditure & Revenue Details

FUND	Unit	Appt	Budget Object	Budget Object Name	FY25 Recommended	FY24 Amended	FY23 Actual
131	8491	WRA020	6111	Regular Employees	349,700	291,820	177,379
131	8491	WRA020	6112	Temporary Employees	416	535	408
131	8491	WRA020	6113	Overtime	2,447	1,997	2,371
131	8491	WRA020	6121	PERS	63,254	57,285	33,675
131	8491	WRA020	6122	Other Post-Employment Benefits	17	670	855
131	8491	WRA020	6131	FICA	20,992	6,144	9,833
131	8491	WRA020	6132	Medicare	5,079	4,281	2,635
131	8491	WRA020	6141	Flex Co Paid Insurance-Pretax	5,706	4,542	2,576
131	8491	WRA020	6142	Life Insurance	323	204	132
131	8491	WRA020	6143	Long-Term Disability Insurance	458	228	151
131	8491	WRA020	6144	Short-Term Disability Insurance	578	252	159
131	8491	WRA020	6145	Dental Insurance	1,432	1,092	743
131	8491	WRA020	6147	Vision Insurance	435	396	244
131	8491	WRA020	6148	Unemployment Insurance	183	277	175
131	8491	WRA020	6161	Workers Compensation Insurance	34,854	7,596	6,172
131	8491	WRA020	6171	Employee Assistance Program	74	-	4
131	8491	WRA020	6173	Flex-Benefit Plan Contribution	55,452	49,656	23,472
131	8491	WRA020	6174	Special Benefits	2,072	979	942
131	8491	WRA020	6175	Wellness Plan	167	178	-
131	8491	WRA020	6222	Uniforms and Safety Equipment	-	-	41
131	8491	WRA020	6231	Communication Charges - External	1,930	-	-
131	8491	WRA020	6261	Insurance - General Liability (Non-recoverable)	25,151	103,971	15,716
131	8491	WRA020	6262	Insurance - General Liability (Recoverable)	4,340	7,532	1,050
131	8491	WRA020	6266	Insurance - Property	50,170	33,022	5,535
131	8491	WRA020	6268	Insurance - Other	114,649	82,585	157,778
131	8491	WRA020	6311	Bldg Improvements/Maintenance -External	7,800	7,176	5,871
131	8491	WRA020	6321	Equipment Maintenance	7,000	15,030	2,324
131	8491	WRA020	6351	Membership Fees	2,040	600	300
131	8491	WRA020	6361	Noncapital Equipment	3,000	9,348	3,116
131	8491	WRA020	6384	Miscellaneous Supplies	1,000	1,353	451
131	8491	WRA020	6405	Courier Services - Internal	404	1,449	268
131	8491	WRA020	6406	Mail Handling Charges	24	165	111
131	8491	WRA020	6411	Postage and Shipping	299	911	89
131	8491	WRA020	6415	Records Retention Charge - Internal	44	127	27
131	8491	WRA020	6601	Accounting & Auditing Charges	-	215	-
131	8491	WRA020	6603	Data Processing Services - Internal	17,980	165,228	12,744
131	8491	WRA020	6605	Laboratory Services	-	-	110
131	8491	WRA020	6607	Legal Service - Internal	14,500	26,070	10,295
131	8491	WRA020	6609	Other Personnel Services	2,000	2,000	4,753
131	8491	WRA020	6611	Staff Training Services	6,285	-	-
131	8491	WRA020	6613	Other Professional & Special Services	4,880,599	4,916,685	2,725,040
131	8491	WRA020	6801	Publications and Legal Notices	1,000	1,000	909
131	8491	WRA020	6821	Rents and Leases - Equipment	6,287	23,815	(7,839)
131	8491	WRA020	6835	Other Special Departmental Expenses	10,500	10,500	497,633
131	8491	WRA020	6861	Conference/Lodging/Meals/Travel	-	-	38
131	8491	WRA020	6864	Fleet Service Charge	8,768	5,854	3,501
131	8491	WRA020	6866	Vehicle Maintenance - External	3,748	1,077	1,990
131	8491	WRA020	6881	Utilities	-	-	20
131	8491	WRA020	7201	Contribution to Other Agency	-	148,000	-
131	8491	WRA020	7301	Cost Plan Charges	34,718	89,950	23,212
131	8491	WRA020	7532	Vehicles	-	10,350	-
131	8491	WRA020	7533	Right-To-Use Expenditure - Equipment	3,811	3,663	-

## Fund 131 - FY25 Budget Expenditure & Revenue Details

FUND	Unit	Appt	Budget Object	Budget Object Name	FY25 Recommended	FY24 Amended	FY23 Actual
131	8491	WRA020	7534	Right-to-Use Expenditure - Vehicles	12,792	8,797	9,411
131	8491	WRA020	7614	Operating Transfers Out	1,668,000	1,804,104	1,558,054
131	8491	WRA020	4600	Investment Income	86,165	35,988	74,990
131	8491	WRA020	5050	Other State Aid	205,000	1,185,500	-
131	8491	WRA020	5290	Federal Aid Other	900,000	900,000	-
131	8491	WRA020	5415	Special Assessments	4,770,388	4,645,524	4,402,514
131	8491	WRA020	5750	Other Services and Non-Taxable Sales	224,808	760,624	125,008

EXPENDITURES:	7,432,478	7,908,709	5,294,474
REVENUES:	6,186,361	7,527,636	4,602,512

## FUND 132 - SVRP Operations (Zone 2B, 2Z)

## FY25 Budget Summary

### Revenues

Ad-Valorem Taxes	0
Benefit Assessments (Zone 2Z & 23% 2B)	4,995,017
San Luis Obispo County Payment	0
Grants	0
Federal Aid (FEMA, Etc)	0
Lease & Interest Revenue	75,931
Development & Annexation Fees	0
Hydroelectric Revenue	0
Water Delivery & Service Fees	1,067,200
Other Revenues	0
Fund Transfer In	0
Debt Service Funds	0
<b>Total Revenues</b>	<b>6,138,148</b>

### Expenditures

Salaries & Benefits	0
General Liability & Pollution Insurances	66,543
County Cost Allocation Plan	0
Consultant (Non M1W)	0
Monterey One Water	5,096,293
Equipment	0
County Department Charges	0
Other Services Supplies	8,235
Fund Transfers Out	0
Debt Payments (CSIP, SVRP, SVWP)	1,016,000
Debt Service Funds	0
<b>Total Expenditures</b>	<b>6,187,071</b>

**Impact to Fund Balance (48,923)**

**Est. Beginning Fund Balance 1,308,603**

**Est. Ending Fund Balance 1,259,680**



# Fund 131 & 132 - Zone 2B Boundary

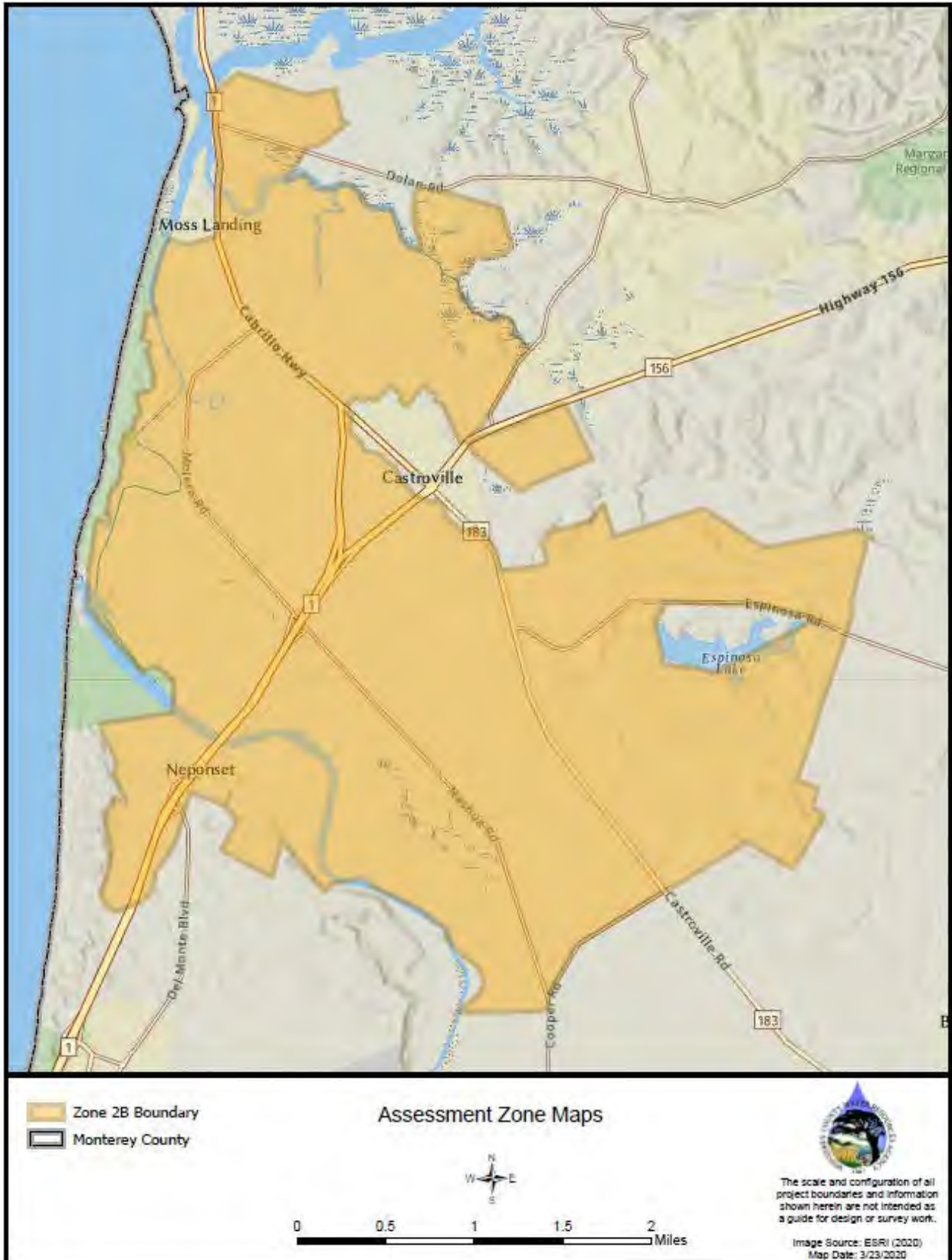

# Fund 132 – SVRP Operations - Zone 2Z Boundary

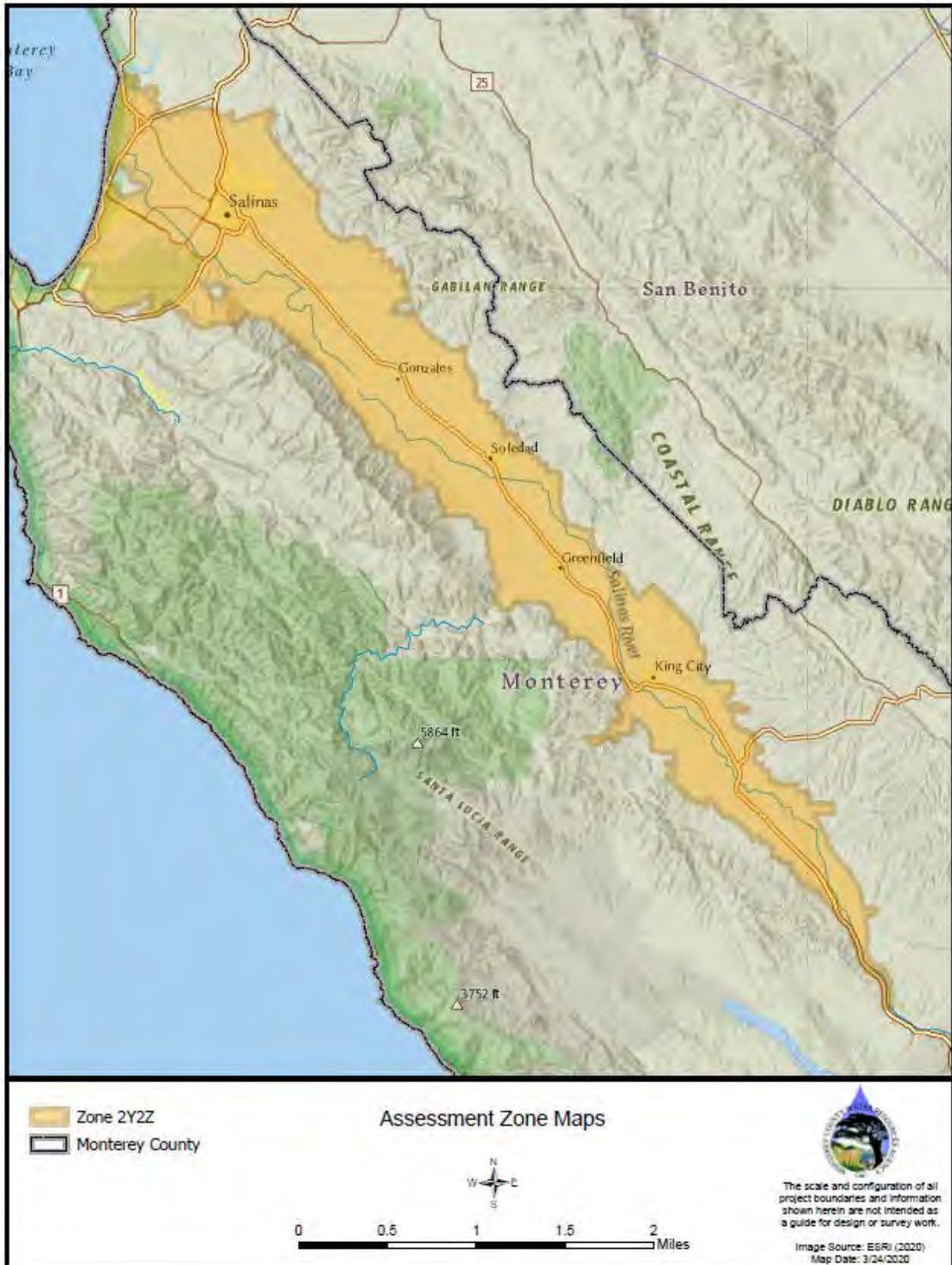

## Fund 132 - FY25 Budget Expenditure & Revenue Details

FUND	Unit	Appt	Budget Object	Budget Object Name	FY25 Recommended	FY24 Amended	FY23 Actual
132	8492	WRA021	6231	Communication Charges - External	1,550	-	-
132	8492	WRA021	6261	Insurance - General Liability (Non-recoverable)	-	66,815	-
132	8492	WRA021	6262	Insurance - General Liability (Recoverable)	-	4,840	-
132	8492	WRA021	6266	Insurance - Property	-	21,221	-
132	8492	WRA021	6268	Insurance - Other	66,543	53,072	-
132	8492	WRA021	6311	Bldg Improvements/Maintenance -External	-	-	-
132	8492	WRA021	6405	Courier Services - Internal	-	1,071	-
132	8492	WRA021	6406	Mail Handling Charges	-	122	-
132	8492	WRA021	6411	Postage and Shipping	-	673	-
132	8492	WRA021	6415	Records Retention Charge - Internal	-	94	-
132	8492	WRA021	6603	Data Processing Services - Internal	-	122,060	-
132	8492	WRA021	6607	Legal Service - Internal	-	14,000	9,410
132	8492	WRA021	6611	Staff Training Services	6,285	-	-
132	8492	WRA021	6613	Other Professional & Special Services	5,096,293	5,029,048	3,353,232
132	8492	WRA021	6801	Publications and Legal Notices	400	400	-
132	8492	WRA021	6821	Rents and Leases - Equipment	-	17,593	-
132	8492	WRA021	7201	Contribution to Other Agency	1,016,000	1,063,000	992,560
132	8492	WRA021	4600	Investment Income	75,931	11,764	44,113
132	8492	WRA021	5415	Special Assessments	4,995,017	5,048,438	4,609,821
132	8492	WRA021	5750	Other Services and Non-Taxable Sales	1,067,200	-	-
					1,292,008		

EXPENDITURES:	6,187,071	6,394,009	4,355,202
REVENUES:	6,138,148	5,060,202	4,653,934

## FUND 134 - SRDF Operations

## FY25 Budget Summary

### Revenues

Ad-Valorem Taxes	0
Special Assessments	0
San Luis Obispo County Payment	0
Grants	1,810,000
Federal Aid (FEMA, Etc)	
Lease & Interest Revenue	61,139
Development & Annexation Fees	0
Hydroelectric Revenue	0
Water Delivery & Service Fees	1,734,932
Other Revenues	
Fund Transfer In	
Debt Service Funds	0

**Total Revenues 3,606,071**

### Expenditures

Salaries & Benefits	459,281
General Liability & Pollution Insurances	105,906
County Cost Allocation Plan	27,894
Consultant (Non M1W)	1,750,000
Monterey One Water	1,286,141
Equipment	0
County Department Charges	26,706
Other Services Supplies	61,544
Fund Transfers Out	0
Debt Payments (CSIP, SVRP, SVWP)	0
Debt Service Funds	0

**Total Expenditures 3,717,472**

**Impact to Fund Balance (111,401)**

**Est. Beginning Fund Balance 2,037,989**

**Est. Ending Fund Balance 1,926,588**



## Fund 134 - FY25 Budget Expenditure & Revenue Details

FUND	Unit	Appt	Budget Object	Budget Object Name	FY25 Recommended	FY24 Amended	FY23 Actual
134	8493	WRA028	6111	Regular Employees	286,758	417,595	192,147
134	8493	WRA028	6112	Temporary Employees	-	-	425
134	8493	WRA028	6113	Overtime	2,007	2,890	1,011
134	8493	WRA028	6121	PERS	64,102	96,629	47,384
134	8493	WRA028	6122	Other Post-Employment Benefits	-	1,010	-
134	8493	WRA028	6131	FICA	17,436	12,336	8,018
134	8493	WRA028	6132	Medicare	4,218	6,159	2,828
134	8493	WRA028	6141	Flex Co Paid Insurance-Pretax	4,322	6,702	2,297
134	8493	WRA028	6142	Life Insurance	259	276	160
134	8493	WRA028	6143	Long-Term Disability Insurance	366	360	230
134	8493	WRA028	6144	Short-Term Disability Insurance	462	396	243
134	8493	WRA028	6145	Dental Insurance	1,090	1,608	610
134	8493	WRA028	6147	Vision Insurance	355	540	235
134	8493	WRA028	6148	Unemployment Insurance	-	418	-
134	8493	WRA028	6161	Workers Compensation Insurance	30,013	11,456	9,790
134	8493	WRA028	6171	Employee Assistance Program	59	-	4
134	8493	WRA028	6173	Flex-Benefit Plan Contribution	46,167	70,896	25,025
134	8493	WRA028	6174	Special Benefits	1,667	1,417	1,450
134	8493	WRA028	6175	Wellness Plan	-	46	-
134	8493	WRA028	6222	Uniforms and Safety Equipment	-	-	2,481
134	8493	WRA028	6231	Communication Charges - External	1,550	-	-
134	8493	WRA028	6261	Insurance - General Liability (Non-recoverable)	21,064	52,872	24,938
134	8493	WRA028	6262	Insurance - General Liability (Recoverable)	2,709	3,830	1,667
134	8493	WRA028	6266	Insurance - Property	43,204	16,793	8,782
134	8493	WRA028	6268	Insurance - Other	38,929	41,997	-
134	8493	WRA028	6311	Bldg Improvements/Maintenance -External	1,000	795	338
134	8493	WRA028	6321	Equipment Maintenance	1,000	5,000	458
134	8493	WRA028	6351	Membership Fees	1,398	-	-
134	8493	WRA028	6361	Noncapital Equipment	10,000	15,000	7,136
134	8493	WRA028	6381	Advertising	-	275	-
134	8493	WRA028	6384	Miscellaneous Supplies	-	-	635
134	8493	WRA028	6404	Courier Services - External	-	-	240
134	8493	WRA028	6405	Courier Services - Internal	325	515	425
134	8493	WRA028	6406	Mail Handling Charges	19	59	43
134	8493	WRA028	6409	Minor Equipment and Furnishings	-	10,000	-
134	8493	WRA028	6411	Postage and Shipping	236	324	142
134	8493	WRA028	6415	Records Retention Charge - Internal	30	46	43
134	8493	WRA028	6603	Data Processing Services - Internal	14,446	58,661	12,603
134	8493	WRA028	6607	Legal Service - Internal	11,650	6,000	3,173
134	8493	WRA028	6609	Other Personnel Services	2,000	4,000	5,334
134	8493	WRA028	6613	Other Professional & Special Services	3,036,141	5,764,461	2,833,328
134	8493	WRA028	6801	Publications and Legal Notices	500	400	-
134	8493	WRA028	6821	Rents and Leases - Equipment	5,052	8,455	(4,278)
134	8493	WRA028	6835	Other Special Departmental Expenses	21,000	21,000	18,920
134	8493	WRA028	6861	Conference/Lodging/Meals/Travel	5,000	5,000	11
134	8493	WRA028	6864	Fleet Service Charge	4,260	5,121	5,555
134	8493	WRA028	6866	Vehicle Maintenance - External	1,818	592	1,079
134	8493	WRA028	6881	Utilities	750	420	400
134	8493	WRA028	7301	Cost Plan Charges	27,894	135,656	36,831
134	8493	WRA028	7532	Vehicles	-	9,060	8,885
134	8493	WRA028	7533	Right-To-Use Expenditure - Equipment	-	5,524	-
134	8493	WRA028	7534	Right-to-Use Expenditure - Vehicles	6,216	7,696	4,278

## Fund 134 - FY25 Budget Expenditure & Revenue Details

FUND	Unit	Appt	Budget Object	Budget Object Name	FY25 Recommended	FY24 Amended	FY23 Actual
134	8493	WRA028	4600	Investment Income	61,139	51,747	73,397
134	8493	WRA028	5050	Other State Aid	1,810,000	3,377,121	923,906
134	8493	WRA028	5750	Other Services and Non-Taxable Sales	1,734,932	1,861,030	1,176,330
134	8493	WRA028	5940	Operating Transfers In		136,104	-

EXPENDITURES:	3,717,472	6,810,286	3,265,304
REVENUES:	3,606,071	5,426,002	2,173,633

## FUND 303 - CSIP Debt Service Fund

## FY25 Budget Summary

### Revenues

Ad-Valorem Taxes	0
Special Assessments	0
San Luis Obispo County Payment	0
Grants	0
Federal Aid (FEMA, Etc)	0
Lease & Interest Revenue	0
Development & Annexation Fees	0
Hydroelectric Revenue	0
Water Delivery & Service Fees	0
Other Revenues	
Fund Transfer In	
Debt Service Funds	1,668,000

**Total Revenues 1,668,000**

### Expenditures

Salaries & Benefits	0
General Liability & Pollution Insurances	0
County Cost Allocation Plan	0
Consultant (Non M1W)	0
Monterey One Water	0
Equipment	0
County Department Charges	0
Other Services Supplies	0
Fund Transfers Out	0
Debt Payments (CSIP, SVRP, SVWP)	0
Debt Service Funds	1,668,000

**Total Expenditures 1,668,000**

**Impact to Fund Balance 0**

**Est. Beginning Fund Balance 0**

**Est. Ending Fund Balance 0**



### Fund 303 - FY25 Budget Expenditure & Revenue Details

FUND	Unit	Appt	Budget Object	Budget Object Name	FY25 Recommended	FY24 Amended	FY23 Actual
303	8267	WRA025	6311	Bldg Improvements/Maintenance -External	-	-	-
303	8267	WRA025	7051	Other Debt Retirement	1,018,000	1,018,000	1,085,360
303	8267	WRA025	7082	Other Interest	650,000	650,000	472,695
303	8267	WRA025	5940	Operating Transfers In	1,668,000	1,668,000	1,558,054

EXPENDITURES:	1,668,000	1,668,000	1,558,055
REVENUES:	1,668,000	1,668,000	1,558,054

**FUND 313 - SVWP Debt Service Fund**

**FY25 Budget Summary**

**Revenues**

Ad-Valorem Taxes	0
Special Assessments	0
San Luis Obispo County Payment	0
Grants	0
Federal Aid (FEMA, Etc)	0
Lease & Interest Revenue	0
Development & Annexation Fees	0
Hydroelectric Revenue	0
Water Delivery & Service Fees	0
Other Revenues	0
Fund Transfer In	0
Debt Service Funds	1,755,338

**Total Revenues 1,755,338**

**Expenditures**

Salaries & Benefits	0
General Liability & Pollution Insurances	0
County Cost Allocation Plan	0
Consultant (Non M1W)	0
Monterey One Water	0
Equipment	0
County Department Charges	0
Other Services Supplies	0
Fund Transfers Out	0
Debt Payments (CSIP, SVRP, SVWP)	0
Debt Service Funds	1,755,338

**Total Expenditures 1,755,338**

**Impact to Fund Balance 0**

**Est. Beginning Fund Balance 0**

**Est. Ending Fund Balance 0**



### Fund 313 - FY25 Budget Expenditure & Revenue Details

FUND	Unit	Appt	Budget Object	Budget Object Name	FY25 Recommended	FY24 Amended	FY23 Actual
313	8494	WRA026	6311	Bldg Improvements/Maintenance -External		-	-
313	8494	WRA026	7041	Bond Principal Payments	860,000	860,000	825,000
313	8494	WRA026	7061	Interest On Bonds	895,338	895,338	933,338
313	8494	WRA026	4600	Investment Income	-	-	759
313	8494	WRA026	4675	Rents, Concessions, and Leases	1,755,338	1,755,338	1,758,338

EXPENDITURES:	1,755,338	1,755,338	1,758,338
REVENUES:	1,755,338	1,755,338	1,759,097

## FUND 426 - Interlake Tunnel Project

## FY25 Budget Summary

### Revenues

Ad-Valorem Taxes	0
Special Assessments	0
San Luis Obispo County Payment	0
Grants	0
Federal Aid (FEMA, Etc)	0
Lease & Interest Revenue	38,234
Development & Annexation Fees	0
Hydroelectric Revenue	0
Water Delivery & Service Fees	0
Other Revenues	0
Fund Transfer In	350,000
Debt Service Funds	0
<b>Total Revenues</b>	<b>388,234</b>

### Expenditures

Salaries & Benefits	145,789
General Liability & Pollution Insurances	0
County Cost Allocation Plan	0
Consultant (Non M1W)	178,588
Monterey One Water	0
Equipment	0
County Department Charges	20,000
Other Services Supplies	30,000
Fund Transfers Out	0
Debt Payments (CSIP, SVRP, SVWP)	0
Debt Service Funds	0
<b>Total Expenditures</b>	<b>374,377</b>

**Impact to Fund Balance 13,857**

**Est. Beginning Fund Balance 661,372**

**Est. Ending Fund Balance 675,230**

Authorized Fund Transfers:

> Receiving Fund Transfer of \$350,000 from Fund 130



## Fund 426 - FY25 Budget Expenditure & Revenue Details

FUND	Unit	Appt	Budget Object	Budget Object Name	FY25 Recommended	FY24 Amended	FY23 Actual
426	8495	WRA036	6111	Regular Employees	89,833	58,717	56,721
426	8495	WRA036	6112	Temporary Employees	-	-	207
426	8495	WRA036	6113	Overtime	-	-	45
426	8495	WRA036	6121	PERS	27,397	16,335	12,417
426	8495	WRA036	6122	Other Post-Employment Benefits	-	174	-
426	8495	WRA036	6131	FICA	6,375	1,382	2,291
426	8495	WRA036	6132	Medicare	1,637	839	797
426	8495	WRA036	6141	Flex Co Paid Insurance-Pretax	1,344	846	824
426	8495	WRA036	6142	Life Insurance	114	36	52
426	8495	WRA036	6143	Long-Term Disability Insurance	215	36	110
426	8495	WRA036	6144	Short-Term Disability Insurance	271	48	116
426	8495	WRA036	6145	Dental Insurance	332	108	211
426	8495	WRA036	6147	Vision Insurance	115	48	77
426	8495	WRA036	6148	Unemployment Insurance	-	71	-
426	8495	WRA036	6161	Workers Compensation Insurance	-	1,991	-
426	8495	WRA036	6171	Employee Assistance Program	19	-	1
426	8495	WRA036	6173	Flex-Benefit Plan Contribution	17,128	9,912	9,577
426	8495	WRA036	6174	Special Benefits	1,009	303	262
426	8495	WRA036	6175	Wellness Plan	-	46	-
426	8495	WRA036	6311	Bldg Improvements/Maintenance -External	-	-	-
426	8495	WRA036	6405	Courier Services - Internal	-	231	-
426	8495	WRA036	6406	Mail Handling Charges	-	20	-
426	8495	WRA036	6407	Minor Computer Hardware	-	-	60
426	8495	WRA036	6411	Postage and Shipping	-	144	-
426	8495	WRA036	6415	Records Retention Charge - Internal	-	16	-
426	8495	WRA036	6606	Legal Service - External	30,000	4,000	48,827
426	8495	WRA036	6607	Legal Service - Internal	20,000	8,962	10,775
426	8495	WRA036	6613	Other Professional & Special Services	178,588	981,716	248,294
426	8495	WRA036	7614	Operating Transfers Out	-	765,200	515,000
426	8495	WRA036	4600	Investment Income	38,234	7,728	19,117
426	8495	WRA036	5050	Other State Aid	-	1,916,419	708,876
426	8495	WRA036	5940	Operating Transfers In	350,000	-	-

EXPENDITURES:	374,377	1,851,181	906,664
REVENUES:	388,234	1,924,147	727,993

# MONTEREY COUNTY WATER RESOURCES AGENCY

## Summary Fund Balance (FB) of FY 2024-25 Recommended Budget

Fund	Fund Name	Zone	FY24 Estimated Beginning FB*	FY24 Adopted Expenditures	FY24 Adopted Revenues	FY24 Adopted FB Use	FY25 Estimated Beginning FB	FY25 Expenditure	FY25 Revenue	FY25 Total FB Use	FY25 Ending Fund Balance
111	Administration Fund		4,310,770	5,374,265	4,909,517	(464,748)	3,846,022	6,578,556	4,978,612	(1,599,944)	2,246,078
112	Pajaro Levee	1 & 1A	1,466,769	3,640,108	2,443,673	(1,196,435)	270,334	1,044,691	1,043,597	(1,094)	269,240
116	Dam Operations (*)	2C	4,438,142	15,024,383	15,548,422	524,039	4,062,181	15,700,462	13,389,245	(2,311,217)	1,750,964
121	Soledad Storm Drain	8	287,577	147,903	106,435	(41,468)	246,109	126,896	109,051	(17,845)	228,264
122	Reclamation Ditch	9	1,283,668	2,648,376	2,650,886	2,510	1,286,178	1,968,235	2,048,527	80,292	1,366,470
124	San Lorenzo Creek	12	31,644	51,518	47,249	(4,269)	27,375	254,423	247,024	(7,399)	19,976
127	Moro Cojo Slough (^)	17	596,684	610,407	240,667	(369,740)	596,684	582,551	322,873	(259,678)	337,006
130	Hydro-Electric Operations		1,411,628	975,726	789,656	(186,070)	1,225,558	1,134,424	1,177,727	43,303	1,268,861
131	CSIP Operations	2B & 2Y	3,253,270	7,908,709	7,527,636	(381,073)	2,872,197	7,432,478	6,186,361	(1,246,117)	1,626,080
132	SVRP Operations (**)	2B & 2Z	2,642,410	6,394,009	5,060,202	(1,333,807)	1,308,603	6,187,071	6,138,148	(48,923)	1,259,680
134	SRDF Operations		3,422,273	6,810,286	5,426,002	(1,384,284)	2,037,989	3,717,472	3,606,071	(111,401)	1,926,588
303	CSIP Debt Service Fund		770,672	1,668,000	1,668,000	0	770,672	1,668,000	1,668,000	0	770,672
313	SVWP Debt Service Fund		1,035,750	1,755,338	1,755,338	0	1,035,750	1,755,338	1,755,338	0	1,035,750
426	Interlake Tunnel Project		588,406	1,851,181	1,924,147	72,966	661,372	374,377	388,234	13,857	675,229
<b>Total:</b>			<b>25,539,662</b>	<b>54,860,209</b>	<b>50,097,830</b>	<b>(4,762,379)</b>	<b>20,247,023</b>	<b>48,524,974</b>	<b>43,058,808</b>	<b>(5,466,166)</b>	<b>14,780,857</b>

(\*) FY25 Estimated Beginning FB reflecting actuals of FY24

(^) FY25 Estimated Beginning FB reflecting postponement of tidegate construction to FY25



# Summary Discussion

- Today's Workshop Presentations:
  - The 2024-25 “baseline” budget
  - Nacimiento Hydroplant Status Report
  - Monterey County Water Recycling Projects Budget Need
  - San Antonio & Nacimiento Budget Needs
  - Recommended Next Steps



# FY 2024-25 (FY25) Preliminary Budget Review



# FY25 Budget

## Plan & Approach was to:

- Achieve Balanced Budget
- Encourage participations by unit & project managers
- Pilot test project & program-based budgets
- Utilize Financial Forecasting Model
- Right-size staff to accomplish planned projects

# FY25 Budget

## Constraints :

Revenue growth does not support expenses needed for increased O&M cost, needed staffing and major repair and replacement projects

- Revenues with zones & rate Restrictions
  - Flood Assessments & Special Assessments
  - Water Service Charge
- Revenues with “beyond control” factors
  - Hydro-Electric Revenue
  - Ad Valorem Taxes
- Revenues for special purpose
  - Grants
  - Grazing Leases & Annexation Fees
  - Boat Dock
  - SLO County Reimbursements
- Revenue adjustable for operational needs
  - Water Delivery Fee

# FY25 Budget - Expenditures

## Reductions made to staff requests:

- Totals requested by staff - \$56,175,000
  - \$1.13M Salaries and Benefits
    - 4 Positions unfunded & 6 Positions partially funded
  - \$6.67M Services and Supplies
  - Examples of Reductions made:
    - Fund 116 – Reduced by \$2.97M
    - Fund 122 – Reduced by \$198K
    - Fund 131 – Reduced by \$1.59M
    - Fund 132 – Reduced by \$1.54M
    - Fund 134 – Reduced by \$2.52M

# FY25 Budget – Preliminary Review

## Total Appropriations :

- \$48,524,974 Expense
  - 12% decrease over FY24 \$54,860,209

## Total Revenue :

- \$43,058,808 Revenue
  - 14% decrease from FY24 \$50,097,830
  - CPI: Feb CPI will be released on March 12, 2024

# FY25 Budget – Preliminary Review

## Expenditure Considerations:

- Statutorily balanced by using \$5.47M Fund Balances
- Changes to Org Structures
- Total 57 FTE
  - 6 FTE newly requested
  - 4 Positions unfunded & 6 Positions partially funded
  - 51 FTE fully/partially funded positions
- Focusing on ongoing operations & maintenance activities
  - Limited major repair and replacement projects
  
- Budget amendments will be needed for projects & staff to be funded by grants

# FY25 Positions Requested

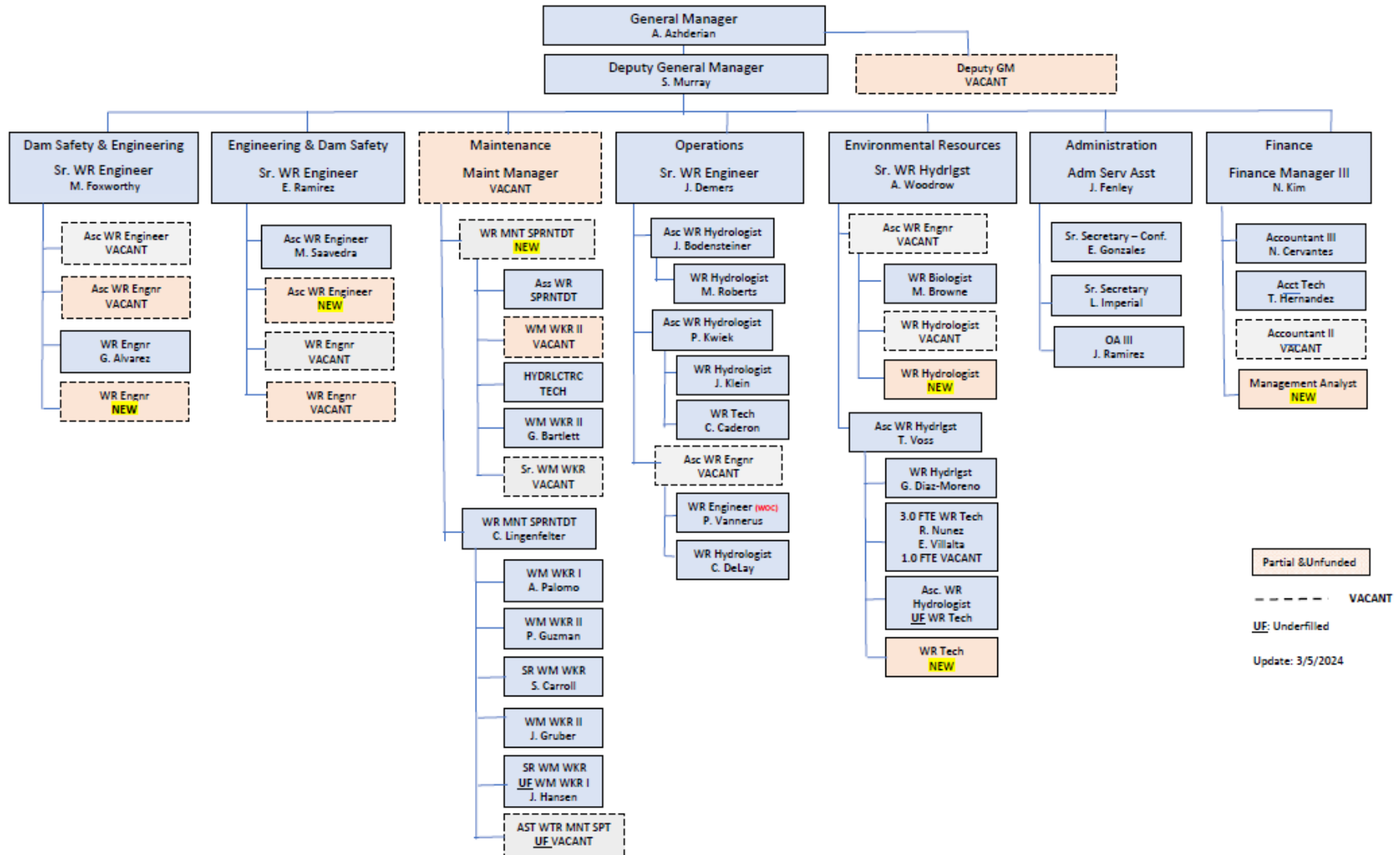

Partial & Unfunded  
 - - - - - VACANT  
 UF: Underfilled  
 Update: 3/5/2024



# FY25 Budget – Preliminary Review

## Expenditures

	FY25 Budget	FY24 Amended	Variance
EXPENDITURES:	48,524,974	54,860,209	-12%
REVENUES:	43,058,808	50,097,830	-14%
<b>EXPENDITURES CATEGORIES:</b>	<b>48,524,974</b>	<b>54,860,209</b>	<b>-12%</b>
Salaries and Benefits	8,755,473	8,337,215	5%
GL & Pollution Insurances	1,781,691	1,260,386	41%
County Cost Allocation Plan	573,662	1,828,247	-69%
Consultants (Non M1W)	15,049,497	16,102,077	-7%
Monterey One Water Contract	9,163,033	9,557,314	-4%
EQUIPMENT & VEHICLES (Capital)	-	39,570	-100%
County Department Charges	823,259	1,080,653	-24%
Other Services & Supplies	3,616,209	5,863,767	-38%
Fund Transfer Out	899,474	2,881,304	-69%
Debt Payments (SVWP, CSIP, SVRP)	4,439,338	4,486,338	-1%
Debt Service Funds	3,423,338	3,423,338	0%

# FY25 Budget – Preliminary Review

## Expenditure Distribution

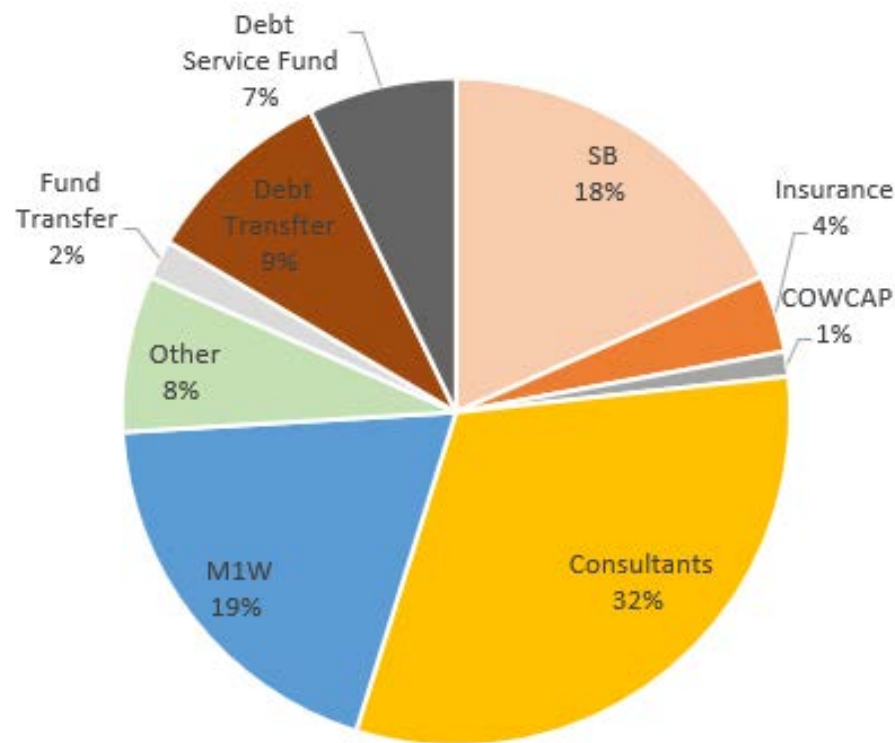

# FY25 Budget – Preliminary Review

## Revenues

	FY25 Budget	FY24 Amended	Variance
EXPENDITURES:	48,524,974	54,860,209	-12%
REVENUES:	43,058,808	50,097,830	-14%
<b>REVENUES CATEGORIES:</b>	<b>43,058,808</b>	<b>50,097,830</b>	<b>-14%</b>
AD-VALOREM TAXES	3,447,294	3,084,317	12%
SVWP ASSESSMENTS	1,145,102	1,199,766	-5%
FLOOD CONTROL ASSESSMENTS	2,199,984	2,116,008	4%
ZONE 2C ASSESSMENTS	4,520,677	4,619,495	-2%
CSIP-SVRP ASSESSMENTS	9,765,405	9,693,962	1%
ROYALTIES REVENUE	614,070	582,600	5%
GRANTS	8,781,900	15,591,540	-44%
Federal Aid (FEMA, etc)	900,000	2,437,750	-63%
RENT & INTEREST REVENUE	960,081	547,528	75%
DEVELOPMENT & ANNEXATION FEES	208,000	208,000	0%
HYDROELECTRIC REVENUE	1,140,961	772,856	48%
WATER DELIVERY & SERVICE FEES	3,026,940	2,621,654	15%
Other Revenues	660,582	529,619	25%
TRANSFERS	2,264,474	2,669,397	-15%
Debt TRANSFERS (CSIP & SVWP)	3,423,338	3,423,338	0%
<b>UNASSIGNED FUND BALANCE</b>	<b>(5,466,166)</b>	<b>(4,762,379)</b>	
EST. BEGINNING FUND BALANCE:	20,247,023	25,539,662	
EST. ENDING FUND BALANCE:	14,780,857	20,777,283	

# FY25 Budget – Preliminary Review

## Revenues

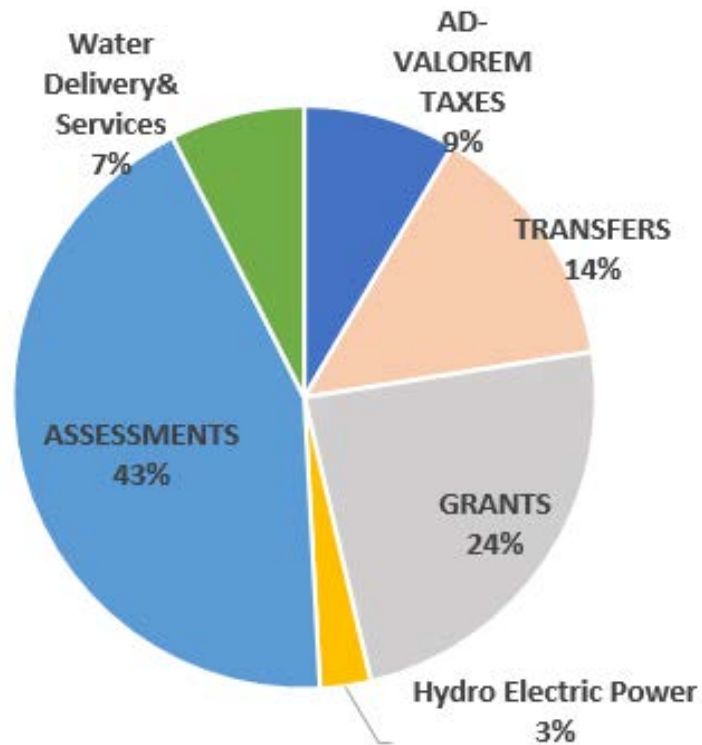

# FY25 Budget – Preliminary Review

Fund Balances *ESTIMATES*

	FY25 Budget	FY24 Amended	Variance
EXPENDITURES:	48,524,974	54,860,209	-12%
REVENUES:	43,058,808	50,097,830	-14%
EST. BEGINNING FUND BALANCE:	20,247,023	25,539,662	
EST. ENDING FUND BALANCE:	14,780,857	20,777,283	



# FY25 Budget - Expenditures

EXPENDITURES CATEGORIES:	FY25 Requested	FY24 Amended	% Increase
Salaries - Regular/Temp/OT	5,350,300		
Benefits - Medicare/FICA	456,532		
Benefits - PERS/RETIREMENT	1,383,959		
Benefits - Insurances/PSA/EAP	158,051		
Benefits - WC/UI	191,218		
Benefits - Other Benefits	1,215,413		
<b>Salaries &amp; Benefits</b>	<b>8,755,473</b>	<b>8,337,215</b>	<b>5%</b>
Insurance - County General Liabilities	721,914		
Insurance - Property	268,544		
Insurance - Pollution Coverage + GL	791,233		
<b>INSURANCES</b>	<b>1,781,691</b>	<b>1,260,386</b>	<b>41%</b>
COWCAP	573,662		
<b>COWCAP</b>	<b>573,662</b>	<b>1,828,247</b>	<b>-69%</b>
Courier Services & Mail charges	12,510		
Records Retention Charge - Internal	749		
Legal Services (Internal)	250,000		
Data Processing Services - Internal	560,000		
<b>COUNTY CHARGES</b>	<b>823,259</b>	<b>1,080,653</b>	<b>-24%</b>



# FY25 Budget - Expenditures

## Monterey One Water

Dept	OB_G rou	FY23 Final	FY24 Adopted Budget	FY25 Request (M1W)	FY25 Rev by M1W	FY25 Proposed by WRA
CSIP-131-55 Total		2,627,868	3,378,805	3,598,813	3,040,813	2,780,599
SVRP-132-50 Total		3,981,907	5,029,048	6,365,110	5,597,190	5,096,293
SRDF-134-57 Total		1,768,008	1,149,461	1,745,580	1,550,580	1,286,141
<b>Grand Total</b>		<b>8,377,783</b>	<b>9,557,314</b>	<b>11,709,503</b>	<b>10,188,583</b>	<b>9,163,033</b>
Capital Outlay		1,613,490	2,106,500	2,231,000	1,180,000	1,180,000
Total O&M		6,764,293	7,450,814	9,478,503	9,008,583	7,983,033
Total M1W Amount		8,377,783	9,557,314	11,709,503	10,188,583	9,163,033
O&M % Increase		10.43%	10.15%	27.21%		7.14%
Total M1W % Increase		25.20%	14.08%	22.52%		-4.13%
			vs. FY23 Final	vs. FY24 Budget		vs. FY24 Budget



# FY25 Budget - Expenditures

EXPENDITURES CATEGORIES:	FY25 Requested	FY24 Amended	% Increase
Grant Reimbursable Consultants	8,775,000		
2023 Winterstorm Repairs (GF Strategic Reserve)	2,092,175		
Other Consultants	6,274,497		
<b>CONSULTANTS</b>	<b>15,049,497</b>	<b>16,102,077</b>	<b>-7%</b>
Building/Equipment Maintenance	650,537		
Non Capital Equipment (including Lease/Rent)	327,794		
Vehicle Maintenance & Leases)	385,465		
Legal Services (External)	70,000		
USGS JP & Other Cooperative Agreements	380,000		
Utilities	234,473		
PRFMA Cost Share and OMRRR payment	494,778		
Membership, Conferences & Training	244,600		
Other Services and Supplies	828,562		
<b>SERVICES &amp; SUPPLIES</b>	<b>3,616,209</b>	<b>5,903,337</b>	<b>-39%</b>
Reline Low Level Conduit - Annual Sinking Fund (116)	105,000		
ILT Funding Opportunity (130 to 426)	350,000		
2023 Winterstorm - Pump Station Repairs (111 to 122)	244,474		
2023 Winterstorm - San Lorenzo Creek (111 to 124)	200,000		
<b>TRANSFERS OUT</b>	<b>899,474</b>	<b>2,881,304</b>	<b>-69%</b>
SVWP Bond (111 to 313)	1,755,338		
USBR CSIP Loan Payment (131 to 303)	1,668,000		
USBR SVRP USBR Loan Payment (132)	1,016,000		
<b>DEBT PAYMENTS</b>	<b>4,439,338</b>	<b>4,486,338</b>	<b>-1%</b>
USBR CSIP Loan Payment (303)	1,668,000		
SVWP Bond (313)	1,755,338		
<b>DEBT SERVICE FUNDS</b>	<b>3,423,338</b>	<b>3,423,338</b>	<b>0%</b>
<b>TOTAL Expenditures:</b>	<b>48,524,974</b>	<b>54,860,209</b>	<b>-12%</b>



# FY25 Budget - Expenditures

## Projects included in FY25 Budget:

- \$854K Salinas River Lagoon Levee Improvements (FEMA + Fund Balance)
- \$50K Rec Ditch Facility Equipment Maintenance Plan
- \$55K Rec Ditch Erosion Repair
- \$450K Moro Cojo Tidegate Repair (PW + Fund Balance)
- \$250K CSIP Cathodic Protection Repair
- \$80K CSIP/SVRP/SRDF Rate Study
- \$1.2M Supplemental Well Replacement (Fed Aid + Fund Balance)
- \$350K ILT Funding Opportunity
- \$325K Repairs at San Antonio
- \$195K Repairs at Nacimiento
- \$200K Low Effect HCP & Stream Maintenance Program

# FY25 Budget - Revenue

## Total Revenue :

\$43,031,808 Revenue

- 14% Decrease from FY24's \$ 50,097,830
- Considerations:
  - Flood & Special Assessments & Water Service Charges:
    - » Annual COLA by CPI % (TBD)
  - Water Delivery Charges at \$64.60/AF to cover increases of utility and chemical cost
    - » FY24 WD Charge = \$37.24
  - Decreased grant revenue estimates

# FY25 Revenues

REVENUES CATEGORIES:	FY25 Budget	FY24 Amended	% Change
FUND 111;112;121;122;124	3,447,294		
AD-VALOREM TAXES	3,447,294	3,084,317	12%
SVWP Assessments (Zone 2C)	5,665,779		
Flood Control (Zone 1/1A,8,9,12,17)	2,199,984		
CSIP-SVRP Assessments (Zone 2B, 2Y, 2Z)	9,765,405		
SPECIAL ASSESSMENTS	17,631,168	17,629,231	0%
SLO County O&M Contributions	614,070		
ROYALTIES REVENUE	614,070	582,600	5%
111, 131, 134 & 116 SVBGSA Grant	1,812,000	✓	
116 DWR Dam Safety Projects	1,717,500		
116 Nacimiento Dam Projects	2,961,400	✓	
116 IRWMP	280,000	✓	
116 2021 SECTION 6 HCP	501,000	✓	
116 FIRO Grant	230,000		
116 Weather Modification	170,000		
116 Flood inundation mapping	300,000		
134 Prop 1 Well Destruction Grant	810,000	✓	
131 CSIP Earmarked Federal Aid	900,000	✓	
GRANTS & Federal Reimbursements	9,681,900	18,029,290	-46%

FY25 CPI Increase : 3/12/2024 (estimates using 3%)



# FY25 Revenues - continued

REVENUES CATEGORIES:	FY25 Budget	FY24 Amended	% Change
ALL FUNDS - Interests	635,281		
116 Rents/Grazing Leases	324,800		
116 Boat Dock Fees	147,093		
111 MOU - GSA Supports	151,198		
112 PRFMA Reimbursement	309,168		
111 Permits & other Fees	53,123		
111 Annexation Fees	208,000		
All Other Revenues	1,828,663	1,285,147	42%
130 Hydroelectric Revenue	1,140,961		
HYDROELECTRIC REVENUE	1,140,961	772,856	48%
131 Water Delivery Charge	224,808	✓	
132 Water Delivery Charge	1,067,200		
134 Water Service Fees	1,734,932	✓	
WATER DELIVERY & SERVICE FEES	3,026,940	2,621,654	15%
112 Pajaro County PRFMA Cost Share	170,000	✓	
116 Hydro plant Access Rd Repair (from 001)	1,100,000		
122 Winterstorm Repair Reserve (from 111)	244,474		
124 Winterstorm Repair Reserve (from 111)	200,000		
127 Reimbursement on Tidegate (from 001)	200,000		
426 ILT Funding Opportunity (from 130)	350,000		
313 Bond Payments (from Fund 111)	1,755,338	✓	
303 CSIP USBR Loan Payments (From 131)	1,668,000	✓	
TRANSFERS & DEBT SERVICES	5,687,812	6,092,735	-7%
<b>TOTAL REVENUES :</b>	<b>43,058,808</b>	<b>50,097,830</b>	<b>-14%</b>

# Fund Balances

## MONTEREY COUNTY WATER RESOURCES AGENCY

### Summary Fund Balance (FB) of FY 2024-25 Recommended Budget

Fund	Fund Name	Zone	FY24 Estimated Beginning FB*	FY24 Adopted Expenditures	FY24 Adopted Revenues	FY24 Adopted FB Use	FY25 Estimated Beginning FB	FY25 Expenditure	FY25 Revenue	FY25 Total FB Use	FY25 Ending Fund Balance
111	Administration Fund		4,310,770	5,374,265	4,909,517	(464,748)	3,846,022	6,578,556	4,978,612	(1,599,944)	2,246,078
112	Pajaro Levee	1 & 1A	1,466,769	3,640,108	2,443,673	(1,196,435)	270,334	1,044,691	1,043,597	(1,094)	269,240
116	Dam Operations (*)	2C	4,438,142	15,024,383	15,548,422	524,039	4,062,181	15,700,462	13,389,245	(2,311,217)	1,750,964
121	Soledad Storm Drain	8	287,577	147,903	106,435	(41,468)	246,109	126,896	109,051	(17,845)	228,264
122	Reclamation Ditch	9	1,283,668	2,648,376	2,650,886	2,510	1,286,178	1,968,235	2,048,527	80,292	1,366,470
124	San Lorenzo Creek	12	31,644	51,518	47,249	(4,269)	27,375	254,423	247,024	(7,399)	19,976
127	Moro Cojo Slough (^)	17	596,684	610,407	240,667	(369,740)	596,684	582,551	322,873	(259,678)	337,006
130	Hydro-Electric Operations		1,411,628	975,726	789,656	(186,070)	1,225,558	1,134,424	1,177,727	43,303	1,268,861
131	CSIP Operations	2B & 2Y	3,253,270	7,908,709	7,527,636	(381,073)	2,872,197	7,432,478	6,186,361	(1,246,117)	1,626,080
132	SVRP Operations (**)	2B & 2Z	2,642,410	6,394,009	5,060,202	(1,333,807)	1,308,603	6,187,071	6,138,148	(48,923)	1,259,680
134	SRDF Operations		3,422,273	6,810,286	5,426,002	(1,384,284)	2,037,989	3,717,472	3,606,071	(111,401)	1,926,588
303	CSIP Debt Service Fund		770,672	1,668,000	1,668,000	0	770,672	1,668,000	1,668,000	0	770,672
313	SVWP Debt Service Fund		1,035,750	1,755,338	1,755,338	0	1,035,750	1,755,338	1,755,338	0	1,035,750
426	Interlake Tunnel Project		588,406	1,851,181	1,924,147	72,966	661,372	374,377	388,234	13,857	675,229
<b>Total:</b>			<b>25,539,662</b>	<b>54,860,209</b>	<b>50,097,830</b>	<b>(4,762,379)</b>	<b>20,247,023</b>	<b>48,524,974</b>	<b>43,058,808</b>	<b>(5,466,166)</b>	<b>14,780,857</b>





# FY 2024-25 (FY25) Summary of Each Funds



## FUND 111 - Administration Fund

### Revenues

Ad-Valorem Taxes	3,072,648
Special Assessments (Zone 2C)	1,145,102
Grants	242,000
Lease & Interest Revenue	115,381
Development & Annexation Fees	208,000
Other Revenues	195,481
<b>Total Revenues</b>	<b>4,978,612</b>

### Expenditures

Salaries & Benefits	1,820,159
General Liability & Pollution Insurances	188,234
County Cost Allocation Plan	110,474
Consultant (Non M1W)	1,605,601
County Department Charges	129,671
Other Services Supplies	524,605
Fund Transfers Out	444,474
Debt Payments (CSIP, SVRP, SVWP)	1,755,338
<b>Total Expenditures</b>	<b>6,578,556</b>

**Impact to Fund Balance (1,599,944)**

**Est. Beginning Fund Balance 3,846,022**

**Est. Ending Fund Balance 2,246,078**

### Activities Included:

- SVB GSA Subgrant
- \$1.6M 2023 winter-storm repairs including \$854K Salinas River Lagoon Levee Improvements & \$444K fund transfers
- GEM Expansion Rate Study
- Training & Conferences

## FUND 112 - Pajaro Levee (Zone 1/1A)

### Revenues

Special Assessments (Zone 1 & 1A)	556,319
Lease & Interest Revenue	8,110
Other Revenues	309,168
Fund Transfer In	170,000

<b>Total Revenues</b>	<b>1,043,597</b>
-----------------------	------------------

### Expenditures

Salaries & Benefits	84,307
General Liability & Pollution Insurances	22,569
County Cost Allocation Plan	5,447
Consultant (Non M1W)	20,000
County Department Charges	95,218
Other Services Supplies	817,150

<b>Total Expenditures</b>	<b>1,044,691</b>
---------------------------	------------------

<b>Impact to Fund Balance</b>	<b>(1,094)</b>
-------------------------------	----------------

<b>Est. Beginning Fund Balance</b>	<b>270,334</b>
------------------------------------	----------------

<b>Est. Ending Fund Balance</b>	<b>269,240</b>
---------------------------------	----------------

### Activities Included:

- 6-month of O&M activities reimbursable by PRFMA

## FUND 116 - Dam Operations (Zone 2C)

### Revenues

Special Assessments (Zone 2C)	4,520,677
San Luis Obispo County Payment	614,070
Grants	6,524,900
Lease & Interest Revenue	473,665
Other Revenues	155,933
Fund Transfer In	1,100,000
<b>Total Revenues</b>	<b>13,389,245</b>

### Expenditures

Salaries & Benefits	4,273,217
General Liability & Pollution Insurances	1,051,235
County Cost Allocation Plan	288,699
Consultant (Non M1W)	8,177,460
County Department Charges	426,480
Other Services Supplies	1,378,371
Fund Transfers Out	105,000
<b>Total Expenditures</b>	<b>15,700,462</b>

<b>Impact to Fund Balance</b>	<b>(2,311,217)</b>
-------------------------------	--------------------

<b>Est. Beginning Fund Balance</b>	<b>4,062,181</b>
------------------------------------	------------------

<b>Est. Ending Fund Balance</b>	<b>1,750,964</b>
---------------------------------	------------------

### Activities Included:

- Nacimiento Spillway  
Plunge pool rock outcrop removal
- Spillway Chute Panel 14R  
Repair
- San Antonio Spillway  
replacement design
- Dam communication  
upgrade

## FUND 121 - Soledad Storm Drain (Zone 8)

### Revenues

Ad-Valorem Taxes	14,340
Special Assessments (Zone 8)	87,328
Lease & Interest Revenue	7,383
<b>Total Revenues</b>	<b>109,051</b>

### Expenditures

Salaries & Benefits	58,653
General Liability & Pollution Insurances	6,044
County Cost Allocation Plan	4,430
Consultant (Non M1W)	10,000
Monterey One Water	0
Equipment	0
County Department Charges	4,244
Other Services Supplies	43,525
Fund Transfers Out	0
Debt Payments (CSIP, SVRP, SVWP)	0
Debt Service Funds	0
<b>Total Expenditures</b>	<b>126,896</b>

<b>Impact to Fund Balance</b>	<b>(17,845)</b>
-------------------------------	-----------------

<b>Est. Beginning Fund Balance</b>	<b>246,109</b>
------------------------------------	----------------

<b>Est. Ending Fund Balance</b>	<b>228,264</b>
---------------------------------	----------------

## FUND 122 - Reclamation Ditch (Zone 9)

### Revenues

Ad-Valorem Taxes	350,570
Special Assessments (Zone 9)	1,414,898
Lease & Interest Revenue	38,585
Fund Transfer In	244,474

<b>Total Revenues</b>	<b>2,048,527</b>
-----------------------	------------------

### Expenditures

Salaries & Benefits	957,966
General Liability & Pollution Insurances	100,157
County Cost Allocation Plan	74,824
Consultant (Non M1W)	273,000
County Department Charges	61,657
Other Services Supplies	500,631

<b>Total Expenditures</b>	<b>1,968,235</b>
---------------------------	------------------

<b>Impact to Fund Balance</b>	<b>80,292</b>
-------------------------------	---------------

<b>Est. Beginning Fund Balance</b>	<b>1,286,178</b>
------------------------------------	------------------

<b>Est. Ending Fund Balance</b>	<b>1,366,470</b>
---------------------------------	------------------

### Activities Included:

- O&M activities
- Pump station repairs by 2023 winter storms Repair
- Facility & equipment maintenance plan

## FUND 124 - San Lorenzo Creek (Zone 12)

### **Revenues**

Ad-Valorem Taxes	9,736
Special Assessments (Zone 12)	36,467
Lease & Interest Revenue	821
Fund Transfer In	200,000
<b>Total Revenues</b>	<b>247,024</b>

### **Expenditures**

Salaries & Benefits	33,752
General Liability & Pollution Insurances	3,196
County Cost Allocation Plan	2,514
Consultant (Non M1W)	202,000
County Department Charges	2,410
Other Services Supplies	10,551
<b>Total Expenditures</b>	<b>254,423</b>

<b>Impact to Fund Balance</b>	<b>(7,399)</b>
-------------------------------	----------------

<b>Est. Beginning Fund Balance</b>	<b>27,375</b>
------------------------------------	---------------

<b>Est. Ending Fund Balance</b>	<b>19,976</b>
---------------------------------	---------------

### Activities Included:

- O&M activities
- Repairs of 2023 winter storms damage

## FUND 127 - Moro Cojo Slough (Zone 17)

### Revenues

Special Assessments (Zone 17)	104,972
Lease & Interest Revenue	17,901
Fund Transfer In	200,000
<b>Total Revenues</b>	<b>322,873</b>

### Expenditures

Salaries & Benefits	74,454
General Liability & Pollution Insurances	10,513
County Cost Allocation Plan	4,011
Consultant (Non M1W)	467,848
County Department Charges	3,843
Other Services Supplies	21,882
<b>Total Expenditures</b>	<b>582,551</b>

**Impact to Fund Balance (259,678)**

**Est. Beginning Fund Balance 596,684**

**Est. Ending Fund Balance 337,006**

### Activities Included:

- O&M activities
- Tide-gate construction

## FUND 130 - Hydroplant Operations

### Revenues

Lease & Interest Revenue	36,766
Hydroelectric Revenue	1,140,961
<b>Total Revenues</b>	<b>1,177,727</b>

### Expenditures

Salaries & Benefits	304,256
General Liability & Pollution Insurances	32,984
County Cost Allocation Plan	20,651
Consultant (Non M1W)	265,000
County Department Charges	19,779
Other Services Supplies	141,754
Fund Transfers Out	350,000
<b>Total Expenditures</b>	<b>1,134,424</b>

<b>Impact to Fund Balance</b>	<b>43,303</b>
-------------------------------	---------------

<b>Est. Beginning Fund Balance</b>	<b>1,225,558</b>
------------------------------------	------------------

<b>Est. Ending Fund Balance</b>	<b>1,268,861</b>
---------------------------------	------------------

### Activities Included:

- O&M Activities
- Design for upgrades
- Set-aside emergency repair
- Electrical drawing update

## FUND 131 - CSIP Operations (Zone 2B, 2Y)

### Revenues

Special Assessments (Zone 2Y & 77% 2B )	4,770,388
Grants	205,000
Federal Aid (FEMA, Etc)	900,000
Lease & Interest Revenue	86,165
Water Delivery & Service Fees	224,808
<b>Total Revenues</b>	<b>6,186,361</b>

### Expenditures

Salaries & Benefits	543,639
General Liability & Pollution Insurances	194,310
County Cost Allocation Plan	34,718
Consultant (Non M1W)	2,100,000
Monterey One Water	2,780,599
County Department Charges	33,251
Other Services Supplies	77,961
Debt Payments (CSIP, SVRP, SVWP)	1,668,000
<b>Total Expenditures</b>	<b>7,432,478</b>

**Impact to Fund Balance (1,246,117)**

**Est. Beginning Fund Balance 2,872,197**

**Est. Ending Fund Balance 1,626,080**

### Activities Included:

- M1W Activities
- Annual Well Maintenance
- System condition/efficiency evaluation
- Cathodic Protection Repair
- Supplemental Well Replacement
- Fund 131 share of Water Delivery Fee @ 11.24 ac/ft water

## FUND 132 - SVRP Operations (Zone 2B, 2Z)

### Revenues

Benefit Assessments (Zone 2Z & 23% 2B)	4,995,017
Lease & Interest Revenue	75,931
Water Delivery & Service Fees	1,067,200
<b>Total Revenues</b>	<b>6,138,148</b>

### Expenditures

General Liability & Pollution Insurances	66,543
Monterey One Water	5,096,293
Other Services Supplies	8,235
Debt Payments (CSIP, SVRP, SVWP)	1,016,000
<b>Total Expenditures</b>	<b>6,187,071</b>

**Impact to Fund Balance** (48,923)

**Est. Beginning Fund Balance** **1,308,603**

**Est. Ending Fund Balance** **1,259,680**

### Activities Included:

- M1W Activities
- Fund 132 share of a new Water Delivery Fee @ 53.36 ac/ft water

## FUND 134 - SRDF Operations

### Revenues

Grants	1,810,000
Lease & Interest Revenue	61,139
Water Delivery & Service Fees	1,734,932
<b>Total Revenues</b>	<b>3,606,071</b>

### Expenditures

Salaries & Benefits	459,281
General Liability & Pollution Insurances	105,906
County Cost Allocation Plan	27,894
Consultant (Non M1W)	1,750,000
Monterey One Water	1,286,141
County Department Charges	26,706
Other Services Supplies	61,544
<b>Total Expenditures</b>	<b>3,717,472</b>

<b>Impact to Fund Balance</b>	<b>(111,401)</b>
-------------------------------	------------------

<b>Est. Beginning Fund Balance</b>	<b>2,037,989</b>
------------------------------------	------------------

<b>Est. Ending Fund Balance</b>	<b>1,926,588</b>
---------------------------------	------------------

### Activities Included:

- SVB GSA subgrant
- Prop 1 Well Destruction grant
- M1W Activities
- 2023 winter storm damage – pending cost estimate and FEMA approval - a ***budget Amendment will be needed***

## FUND 426 - Interlake Tunnel Project

### Revenues

Lease & Interest Revenue	38,234
Fund Transfer In	350,000
<b>Total Revenues</b>	<b>388,234</b>

### Expenditures

Salaries & Benefits	145,789
Consultant (Non M1W)	178,588
County Department Charges	20,000
Other Services Supplies	30,000
<b>Total Expenditures</b>	<b>374,377</b>

**Impact to Fund Balance 13,857**

**Est. Beginning Fund Balance 661,372**

**Est. Ending Fund Balance 675,230**

### Activities Included:

- Transfer of \$350K to seek alternative funding sources for the ILT project

# Schedules

## FY25 Budget Development Schedules:

- 1/2/24 FY24 Year End Estimates and 3-year forecasts
- 1/26/24 FY25 Position Change reviewed and approved by HR
- 3/1/24 Submitted Baseline Requests to County
- 3/18/24 WRA BOD Budget Workshop
- 3/22/24 County Department Head Budget workshop
- 4/5/24 Requested Budget to WRA Finance Committee
- 4/15/24 Requested Budget and FY25 Assessments Rates/Water Delivery/Service Fees to WRA BoD
- 5/29&30/24 County BoS Budget Hearing & Adopting FY24-25 COLA adjustments to Special Assessment
- 6/20/24 County BoS Budget Adoption







# Status report on the Nacimiento Dam Hydroelectric Power Plant

Manuel Saavedra, Associate Water Resources Engineer

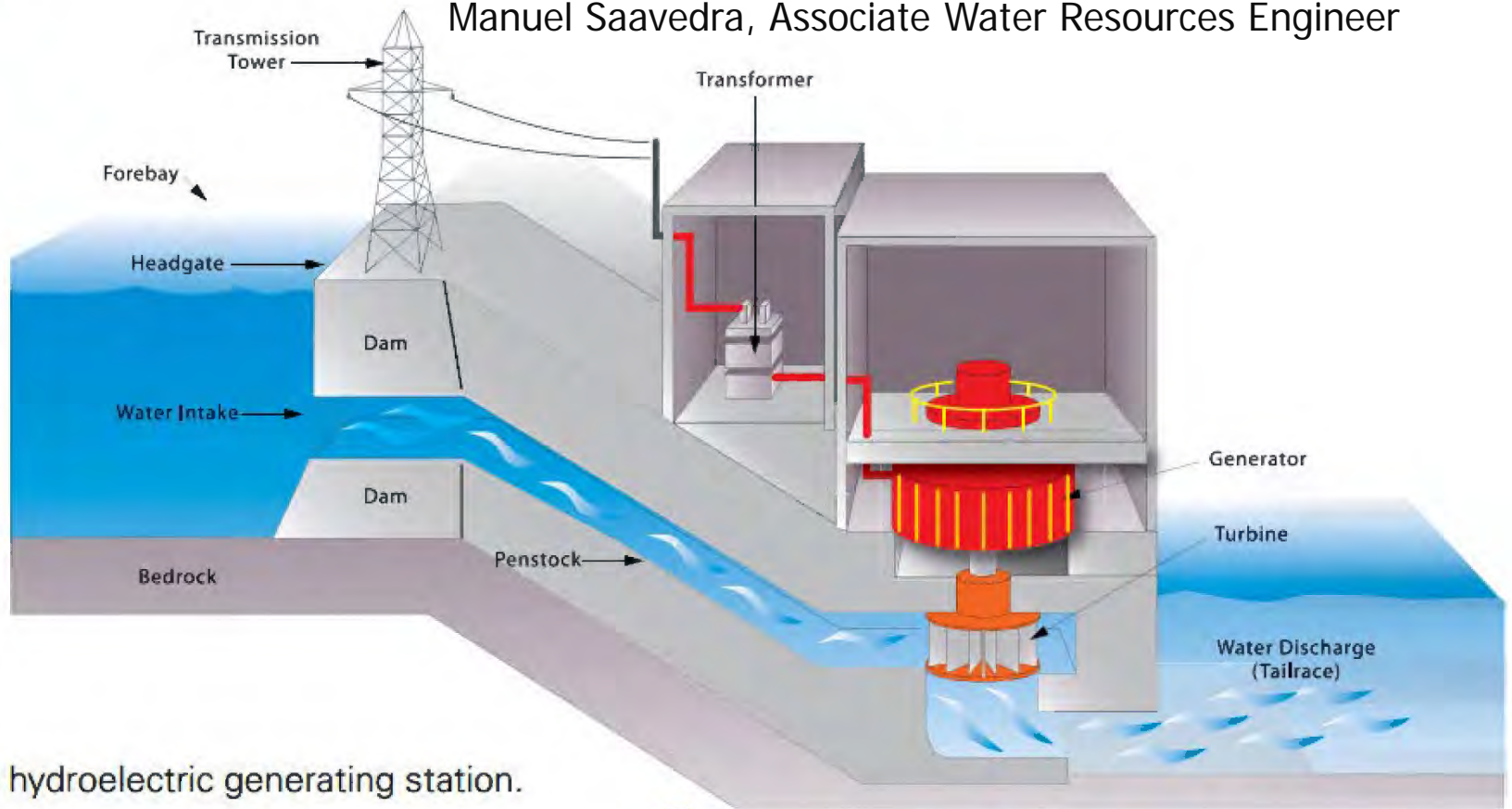

Diagram of a hydroelectric generating station.



# Discussion

- The Nacimiento Dam Hydroelectric Power Plant is equipped with two power units, Unit 1 & 2.



# Discussion

- Unit 1 is the primary power generator with a nameplate capacity of 3.976 megawatts (MW) and designed to operate during reservoir releases for flood control and conservation.
- Flow operating range is 150-350 cubic feet per second (CFS), with a reservoir water elevation between 690-800 feet.

# Discussion (cont.)

- Unit 2 is the secondary power unit with a nameplate capacity of 0.375 MW and designed to generate power from the original minimum release flow of 25 CFS with a reservoir water elevation between 728-800 feet.
- Unit 2 is typically operated outside flood control and conservation release conditions, during drought years, or when Unit 1 is unavailable.

# Discussion (cont.)

- In 2014, the Agency secured a Power Purchase Agreement with the Northern California Power Agency (NCPA) to sell power generated through 2033.
- Revenue from power sales for the period 2014-2023 was approximately \$6,324,000. The annual revenue per power unit is shown on the following graph.

# Discussion (cont.)

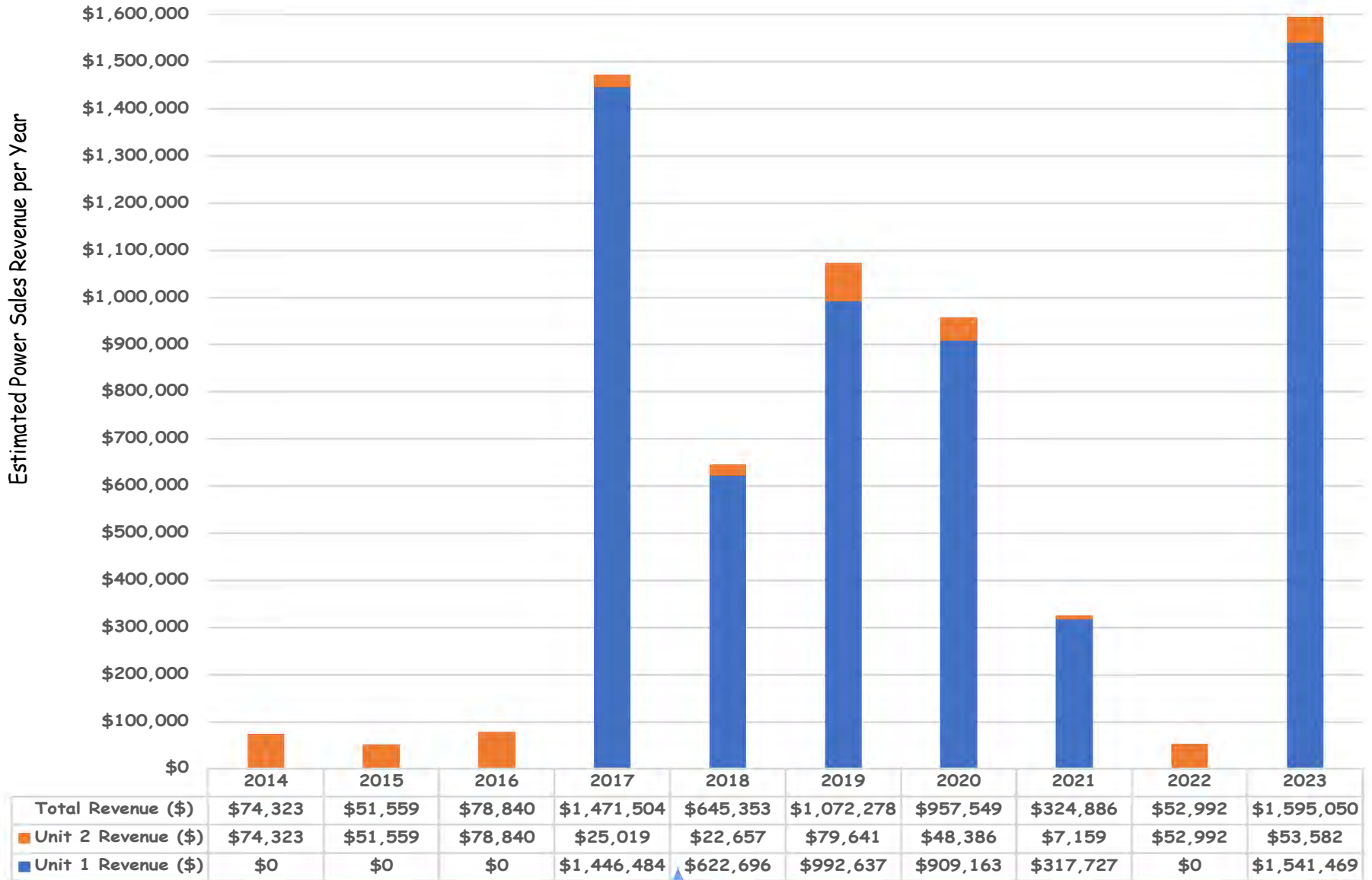

# Discussion (cont.)

- Recently, Unit 2 failed due to a damaged generator.
- In addition, staff has observed the turbine of Unit 2 is showing signs of wear and negatively impacting generation.
- The last overhaul of the generator and turbine was completed in 2003. Recommended industry standards is a component level inspection every 5-10 years, depending on equipment use.

# Summary

- Option 1: Repair generator. Cost is approximately \$55,000. Funds are available in FY 23-24 budget.
- Option 2: Repair generator and overhaul turbine. Cost is approximately \$320,000.
- Staff recommends Option 2 for the following reasons:
  - Timing opportunity,
  - Cost,
  - Will restore original equipment efficiency,
  - Provide a long-term repair solution.

\*Funding for Option 2 requires inclusion to FY 24-25 base budget.

# Monterey County Water Recycling Projects: FY 25 Budget

Peter Vannerus  
Associate Water Resources Engineer

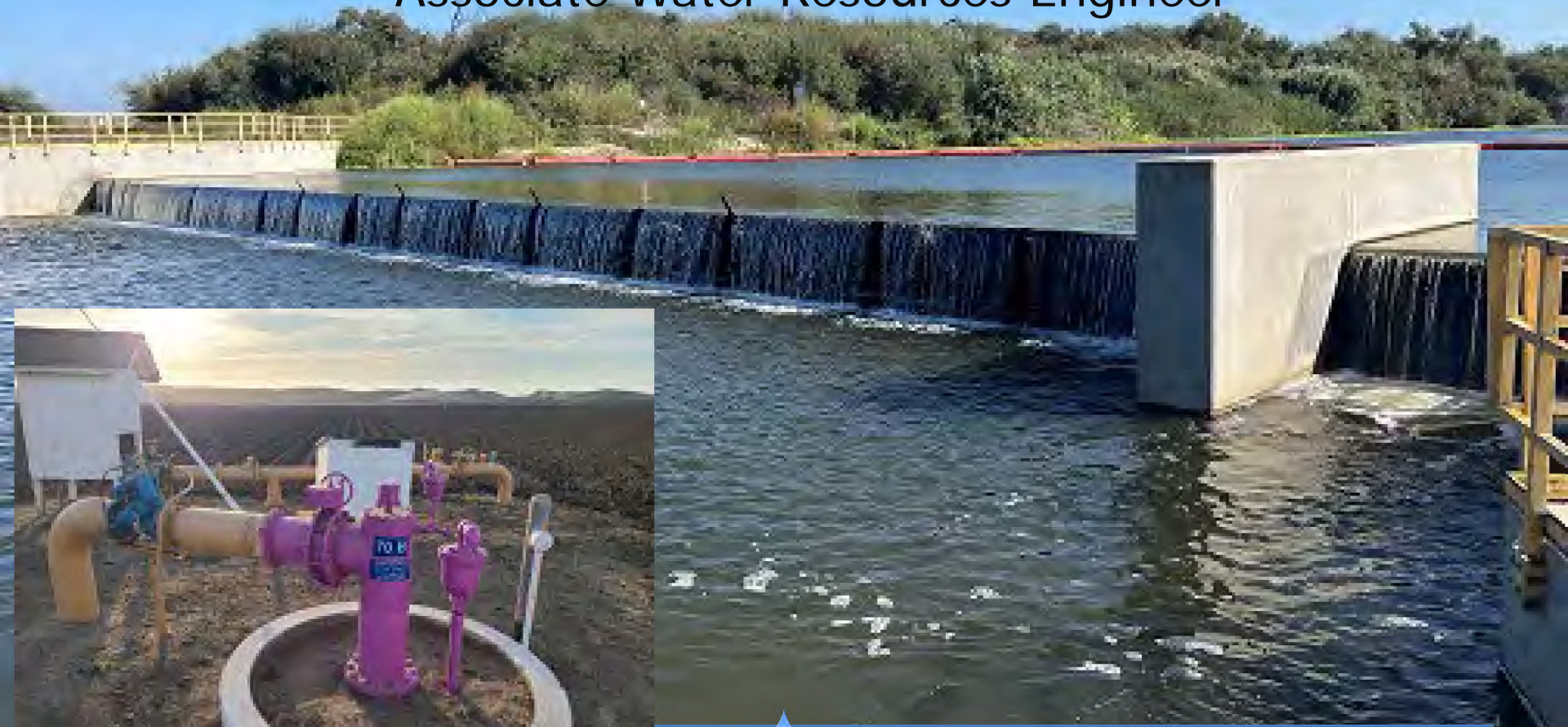

# Monterey County Recycle Water Projects (RWP)

- Increased operation and maintenance costs across the entire RWP including CSIP/SVRP/SRDF
- Operating cost increases include:
  - Utilities (primarily electricity)
  - Chemicals (primarily Chlorine and Coagulation & Flocculation Polymer)
  - FY25 utility and chemical costs are estimated to increase by at least 20%
- M1W Salary increases
- Increased maintenance needed on aging equipment

# Monterey County Recycle Water Projects (RWP)

- FY25 revenue is not enough to pay for projected operations and maintenance costs or essential Capital Improvement Plan (CIP) projects
- The FY25 proposed budget includes reductions from requested funding in all three RWP funds (CSIP, SVRP, and SRDF)
  - Impacts both WRA and M1W O&M
- To accommodate increasing cost of essential O&M activities the **proposed FY25 budget includes Increasing the Water Delivery Fee to \$64.60/AF by Ordinance No. 03789 (Zone 2B Water Deliver Charge Establishment)**

# Monterey County Recycle Water Projects (RWP)

- Even with the increased water delivery fee, FY25 proposed budget includes cuts to M1W budget requests
- Critical Capital Improvement Projects cut or postponed include:
  - Maintenance or replacement of critical components
    - Electrical components
    - Control systems
    - Heavily used infrastructure
- Failure of these critical components or systems would result in extended service outages

# Monterey County Recycle Water Projects (RWP)

FY25 proposed budget also requires postponement of WRA recommended projects including:

- System optimization projects
  - Flow meter calibration, valve replacement
- New source water investigation
- Well maintenance and replacement
  - Maintenance plan reduced by 66%
  - Work on second replacement well postponed
- Critical SRDF projects
  - Updates to hardware and software system controls
  - DSOD required repair of winter 2023-24 storm damages
  - Repairs to the bladders and other weir components



# Monterey County Recycle Water Projects (RWP)

- To ensure we are able to continually move toward the RWP goal of halting seawater intrusion, the WRA and M1W need to plan for long term sustainability of the system and water sources
- A thorough assessment of RWP infrastructure is needed to inform effective planning of preventative maintenance actions
- Create increased system reliability by:
  - Assessing critical failure points in the system and addressing existing issues
  - Planning and budgeting for future repair and maintenance of aging infrastructure
- Move from reactive to proactive system repairs and maintenance



# FY25 Budget Routes

## Base Rate:

- FY25's Water Delivery Fee at \$64.60 is needed to fund essential O&M activities of CSIP and SVRP operations

# FY25 Budget Routes

- Recommended Alternative #1
  - Base Rate + Additional increased by \$25
  - Funds critical CIP items and maintenance projects :
    - Well Maintenance Plan
    - Flow meter calibrations
    - New source water investigation
    - Design of the second replacement well

# FY25 Budget Routes

- Recommended Alternative #2
  - Base Rate + Additional increased by \$174.35
  - Fully funds the projects proposed for maintenance and improvements FY25:
    - M1W initial requests
    - CIP control system upgrades
    - Booster station maintenance
    - Second well funded for construction

# Summary

- Fund revenues are not adequate to keep up with increasing costs and necessary maintenance
- Aging infrastructure and inadequate maintenance and repair funding increase the potential for extended service outages
- Water Delivery Fee needs to increase to meet system needs for SVRP & CSIP
- SRDF funding mechanisms differ and require additional actions to modify



# FISCAL YEAR 2024-2025 BUDGET WORKSHOP

## SAN ANTONIO DAM

Elise Ramirez, PE  
Senior Water Resources Engineer

# SAN ANTONIO DAM

- Construction completed in 1967
- Storage at Elev. 780' = 335,000 acre-feet
- Department of Water Resources Division of Safety of Dams Jurisdiction
  - Current National Inventory of Dams Condition Assessment: "Fair" (4/12/2019)
  - Extremely High Hazard Dam due to downstream population
- Regulatory Compliance Trends
- Spillway Replacement Project (req'd project)

# SAN ANTONIO DAM FY 25

## Staff Requested Budget Methodology for FY 25:

- Staffing
  - Projects by anticipated FTE's
  - Staff workload considerations
  - Regulatory compliance trends
- Project schedules, phase, reservoir conditions
- Regulatory review timelines
- Environmental considerations/permitting
- Consultant use (technical expertise due to unique facility)

Resulted in a needed, realistic, and achievable staff budget request.

# SAN ANTONIO DAM FY 25

## Project Requests

- Identified Needs
  - Aging infrastructure
  - Dam Safety Projects
    - Annual inspection notes
    - Unfunded Projects
- Anticipated DSOD changes

# SAN ANTONIO DAM FY 25

## Staffing Requests

- Expand on the separation of the dams to two Senior Water Resources Engineers from FY 24.
  - Compliance
  - Aging Infrastructure
- Strategic Planning Organization Chart
  - Associate WRE (request to partially fund)
  - WRE (partially funded within FY 25 budget)
- Grant Funds - Staff effort to fund projects
  - Secured (SB 104 Dept of Water Resources \$17m)
    - \$3m for San Antonio Spillway Design
  - Pending Applications
  - Anticipated Notice of Funding Opportunities (NOFO's)

# UNFUNDED DAM SAFETY PROJECTS

## San Antonio Low Level Outlet Works

- Boat barrier buoy and log boom
- Bulkhead Gate
- Intake Structure Trash Racks
- Access Hatches
- Air Vacuum Valves
- Butterfly Valve Hydraulics
- Penstock Coating
- Low Level Discharge Valve

**NOTE:** DWR Grant Application (local match req'd.)

**NOTE:** San Antonio Dam Spillway

» Anderson Dam

# SA PROJECT FY 25 NEEDS

- LLOW FY 25 = **+\$1,000,000** (Design/Planning)
  - Total LLOW Project Estimate = \$8,000,000
- **12” Horizontal Drain FY = +\$120,000**
  - FY 24 80% Design (active project)
  - FY 25 Staff Request Total = \$220,000
  - FY 25 Baseline Budget = \$100,000
- Left abutment drains = **+\$60,000**
- Heavy equipment = **+\$350,000**

Examples of additional need to FY 25 Budget = **+\$1.53m\***

\*not including staffing requests

# SA STAFF FY 25 NEEDS

## Fund the Proposed FY25 Organizational Chart

- San Antonio Dam Engineering Section
  - (1) Associate Water Resources Engineer (unfunded)
    - Request is to fully fund for FY 25
  - (1) Water Resources Engineer (50% funded)
    - Request to fully fund for FY 25

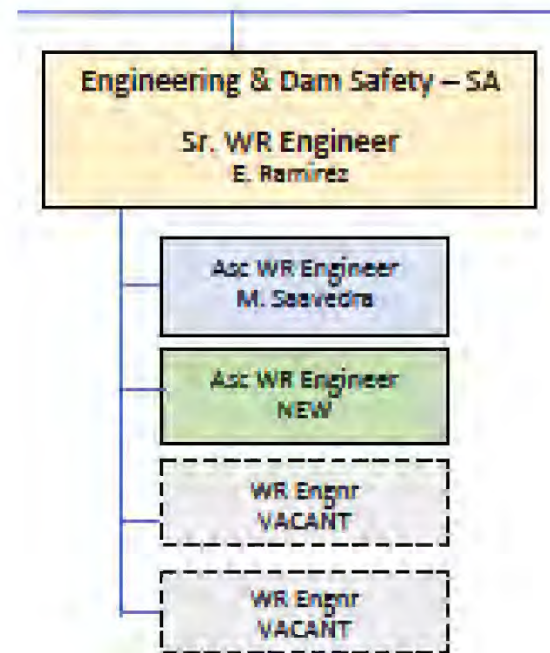

# SUMMARY

- FY 25 Staff Budget is well thought out
  - Effort was put into considerations for project and staffing need based on workloads, project phasing, and maintaining compliance and overall dam safety.
- Current staff budget needs in addition to the FY 25 Baseline Budget
- The long-term need given all aforementioned considerations will remain.
- Increasing regulatory mandates alongside aging infrastructure

**GOAL:** to maintain regulatory compliance and have little to no operational impacts and/or restrictions.



# FISCAL YEAR 2024-2025 BUDGET WORKSHOP

## NACIMIENTO DAM

Mark Foxworthy, PE  
Senior Water Resources Engineer



# NACIMIENTO DAM

- Constructed completed in 1957
- Storage at Elev. 800' = 377,900 acre-feet
- Jurisdiction
  - Federal Energy Regulatory Commission (FERC)
    - Rated “POOR” (2024) for:
      - » Deficiencies, uncertainties, additional studies needed
  - Department of Water Resources Division of Safety of Dams (DSOD)
    - Rated “Satisfactory”

# NACIMIENTO DAM FY 25

## Regulatory Compliance

- FERC-Nacimiento Dam (only)
  - 26 requirements (min)
    - Requirement type: Inspections, surveillance, monitoring, program maintenance, drills, functional exercises, independent program & facility audits, program updates, staff training, reporting, permit application
- DSOD-Both Nacimiento & San Antonio Dams
  - 9 requirements (min)
    - Requirement type: Inspections, surveillance, monitoring, program maintenance, drills, functional exercises, independent program & facility audits, program updates, staff training, reporting
- Programmatic maintenance ongoing/continuous

# NACIMIENTO DAM FY 25

- Funded Projects FY 25
  - Hydro plant South Access Road Repair (FEMA)
  - Plunge pool rock outcrop removal (\$6mil-DWR)
  - Plunge pool RCC slope Protection design (\$6mil-DWR)
  - Spillway Panel 14R repairs (Fund 116 and/or \$6mil-DWR)
- All projects will require
  - Permit support
  - Contract support
  - Grant reporting/documentation
  - Field Engineering/project management
  - On-site maintenance staff support
  - FERC & DSOD approval coordination support

# NACIMIENTO DAM FY 25

## Staffing

- Current-funded
  - 1 Snr. Engrnr-filled
  - 1 Wtr. Rsc. Engrnr-filled
  - 1 Asc. Engrnr-Vacant
  - 1 Asc. Engrnr-50% funded
- Additional staffing needs
  - 1 Asc. Engrnr-50% unfunded
  - 1 Wtr. Rsc. Engrnr-proposed

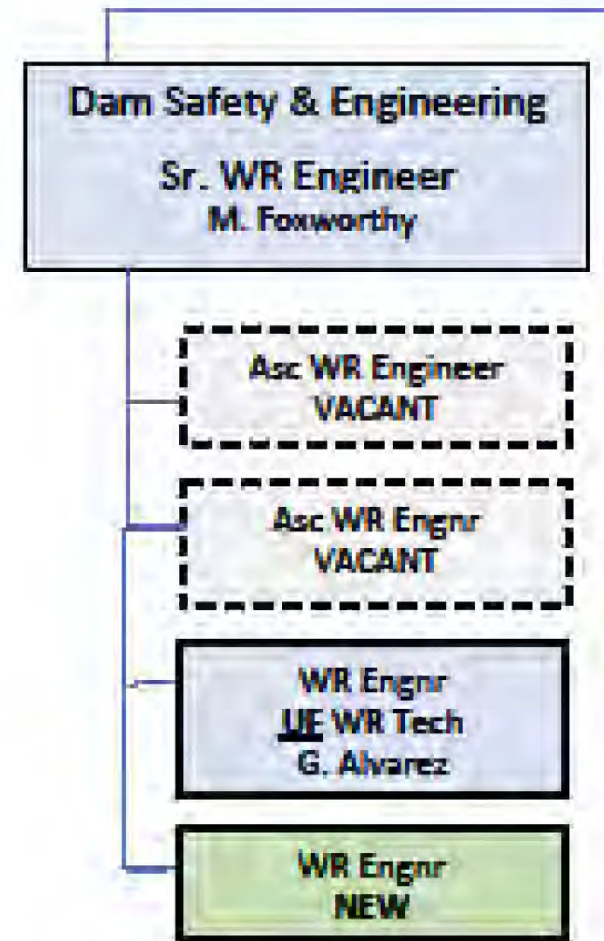

# NACIMIENTO DAM FY 25

Staff Recommends to fund the following:

Fund the Proposed FY25 Organizational Chart

- Nacimiento Dam Engineering Section

- (1) Associate Water Resources Engineer (50% funded)
  - Request to fully fund for FY 25
- (1) Water Resources Engineer (unfunded)
  - Request is to fully fund for FY 25



# Examples of Safety of Dams Regulatory Requirements for FY 25

Example funding needs include the following:

- San Antonio Projects: \$1.53M
  - LLOW, equipment and drain work
- Salaries and benefits for engineering and maintenance staff: \$0.69M
  - Maintenance Manager (0.26 FTE)
  - Water Maintenance Worker (1 FTE)
  - Associate Water Resources Engineers (2 FTE)
  - Water Resources Engineers (2 FTE)

# Summary Discussion

- Recommended Next Steps
  - Monterey County Water Recycling Projects
    - Schedule Growers Workshop
      - Review necessary rate increases
      - Review proposed additional work
      - Set 2024-25 Rates
  - Nacimiento & San Antonio Dam Safety
    - Schedule Stakeholders Workshop
      - Review Regulatory Requirements
      - Present Regulatory Fee or Zone 2C Assessment Rate Increase Proposals





# County of Monterey

**Item No.3**

## Board Report

Board of Supervisors  
Chambers  
168 W. Alisal St., 1st Floor  
Salinas, CA 93901

**Legistar File Number: WRAG 24-041**

**March 18, 2024**

**Introduced:** 3/12/2024

**Current Status:** Draft

**Version:** 1

**Matter Type:** WR General Agenda

Update on the expansion and enhancement of the Agency's Groundwater Extraction Management Systems (GEMS).(Presenter: Ara Azhderian)



# GEMS "EXPANSION"

- February 1, 2024, MCWRA Special BOD Meeting:  
Consensus of the MCWRA (Agency) BOD to work with the Salinas Valley Basin Groundwater Sustainability Agency (SVB) to develop a path forward for expansion and enhancement of the Agency's 30 year-old Groundwater Extraction Management System (GEMS) to meet today's regulatory requirements under the Sustainable Groundwater Management Act (SGMA), while improving the level of service for Agency and SVB stakeholders.

# Current Roles and Responsibilities

## Agency: Data Collection & Management

- Collect groundwater level data
- Administer GEMS well registration program
- Administer GEMS reporting
- Administer water conservation reporting
- Monitor water chemistry in the 180/400 subbasin

## SVB: Governance & Planning for Sustainability

- Responsibility for implementing GSPs in 6 Salinas Valley subbasins
- Prepare annual reports and 5-year GSP evaluations
- Develop sustainable management criteria
- Demonstrate to DWR progress toward sustainability goals set in GSPs
- Coordination and outreach between subbasins and other GSAs

# Potential Changes in Roles

## *IF Agency expands its current GEMS*

### Agency: Data Collection & Management

- Add staffing
- Procure additional equipment
- Expand administration
- Expand registration & reporting
- Modify funding mechanism
- **Leverage** existing institutional knowledge, data collection & reporting practices

### SVB: Governance & Planning for Sustainability

- No changes to current roles and responsibilities
- No change in staffing, administration, or funding

# Why “expansion”?

- Required to comply with SGMA regulations.
  - Formation of Groundwater Sustainability Agencies (GSAs) in lieu of State control.
    - Monterey County has 6
  - Preparation of Groundwater Sustainability Plans (GSPs).
    - Monterey County has 6
  - Reaching groundwater sustainability by 2040.
    - Managing to sustainability requires **data**.

# Why “expansion”?

- Meets the regulatory data collection needs of SVB.
  - 5-year GSP evaluations due
    - 180-400 subbasin: January 2025
    - Other 5 subbasins: January 2027
  
- Addresses DWR Recommended Corrective Actions.
  
- Aligns Agency GEMS boundaries and SVB boundaries.

# Red Circles Are Outside of Current GEMS Program

## Implementation Priorities 2024-2026

- ✓ 180-400 due to GSP 5-Year Evaluation deadline;
- ✓ New extraction reporting in all areas to fill data gaps;
- ✓ Registration of unregistered wells;
- ✓ Enhancements and other cooperative opportunities.

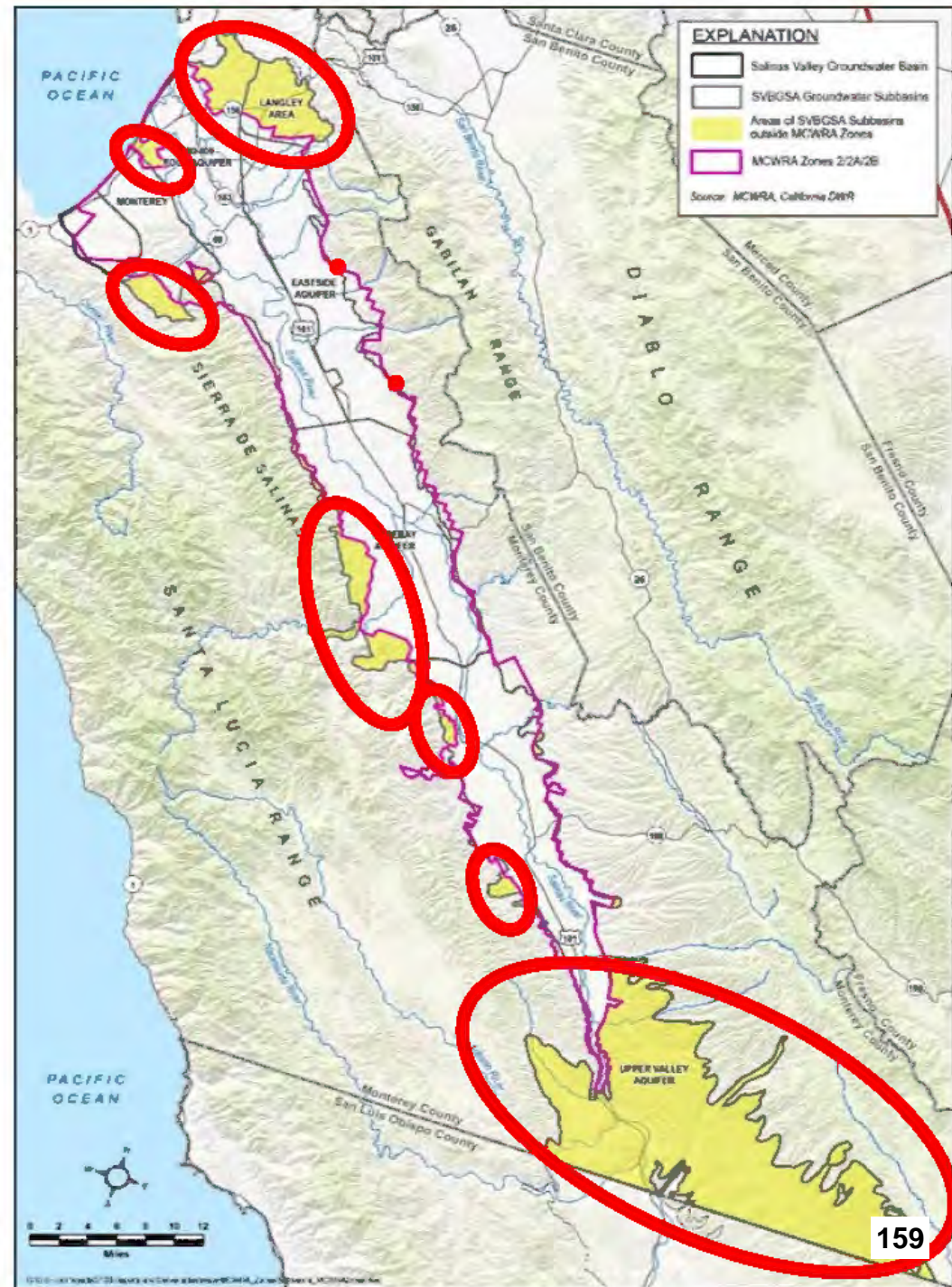

# What changes are being planned?

- Expansion of GEMS to include new reporting requirements in all areas under SVB jurisdiction.
  - Currently in GEMS, wells with a discharge pipe smaller than 3 inches in diameter need not report.
  - Under expansion, all wells using more than 2 AFY will need to report, consistent with SGMA.
  
- Enhancement of GEMS to improve the processes
  - Reporting period
  - Protocols, devices, technology

# What changes are being planned?

- Registration of all wells.
  - Currently in GEMS, wells with a discharge pipe smaller than 3 inches in diameter need not register.
  - Incorporate SVB proposed well registration program with GEMS expansion.
  - Under expansion, all wells will need to register.
  - Known wells will not need to re-register.
  - Any changes to wells, e.g. repair, modification, and destruction, will need to be reported.

# How would new GEMS be funded?

- New approach to cost allocation and recovery.
  - Currently costs are allocated and recovered on a **per-acre basis**.
  - In the future, costs are proposed to be allocated and recovered on a **per-well basis** (reporting requirements are driven by the number of wells, not the number of acres).
- Revenue collected by the Agency or by SVB.
  - Aiming for simpler and more transparent method.

# What are other considerations?

- How to meet future needs through improved cooperation among the agencies with well monitoring and management responsibilities.
  - Arroyo Seco GSA
  - Central Coast Water Quality Preservation, Inc.
  - County of Monterey GSA
  - County of Monterey's Health Department
  - Marina Coast Water District GSA
  - Monterey Peninsula Water Management GSA
  - Others
- Explore opportunities to reduce regulatory complexity, consolidate work and reduce costs.

# In conclusion, “expansion” is:

- To meet the regulatory needs of the SVB for data collection within their jurisdiction;
- Registration of wells not previously registered;
- New reporting requirements;
- Improved processes, greater efficiencies;
- New approach to cost allocation and recovery;
- Opportunity to meet the future needs of others.

# Next Steps

- Working with County Counsel and the SVB, the Agency will draft **one new ordinance** to repeal and replace the three existing GEMS ordinances.
- The new ordinance will affirm the Agency's authority to monitor, collect, and report groundwater data throughout the County, **as needed for its own purposes or for others upon request.**
- The new ordinance will establish the new registration and reporting requirements, **in furtherance of SGMA and SVB policies.**
- The new ordinance will establish a cost recovery method for this regulatory program.

# GEMS Expansion Proposed Timeline

WELL REGISTRATION & GEMS EXPANSION TIMELINE															
Nov '23	Dec '23	Jan '24	Feb '24	Mar '24	Apr '24	May '24	Jun '24	Jul '24	Aug '24	Sep '24	Oct '24	Nov '24	Oct '25	Feb '26	Jan '27
OUTREACH															
			WELL REGISTRATION & GEMS EXPANSION PROPOSAL DEVELOPMENT												
					ORDINANCE, AGREEMENTS, & POLICIES DEVELOPMENT										
								POPULATE WELL REGISTRATION & GEMS EXPANSION DATABASE							
											COLLECT NEW WELL & GEMS DATA				
													REPORT NEW DATA		
														5-YR. GSPs UPDATE	







# County of Monterey

## Item No.4

### Board Report

Board of Supervisors  
Chambers  
168 W. Alisal St., 1st Floor  
Salinas, CA 93901

Legistar File Number: WRAG 24-036

March 18, 2024

**Introduced:** 3/12/2024

**Current Status:** Draft

**Version:** 1

**Matter Type:** WR General Agenda

Approve the Action Minutes of February 20, 2024, and Special Board of Directors Meeting Action Minutes of February 7, 2024.

# County of Monterey

*Board of Supervisors Chambers  
168 W. Alisal St 1st Flr,  
Salinas, CA 93901*



## Meeting Minutes

**Tuesday, February 20, 2024**

**12:00 PM**

### **Water Resources Agency Board of Directors**

*Mike LeBarre, Chair  
Matt Simis, Vice Chair  
Mark Gonzalez  
Deidre Sullivan  
Ken Ekelund  
Mike Scattini  
Jason Smith  
John Ballie  
Marvin Borzini*

**Participation in meetings:**

You may attend the Board of Directors meeting through the following methods:

1. You may attend in person
2. Attend via Zoom (info below) or observe the live stream of the Board of Directors meetings at [http://monterey.granicus.com/ViewPublisher.php?view\\_id=19](http://monterey.granicus.com/ViewPublisher.php?view_id=19) or <http://www.mgtvonline.com/>
3. For ZOOM participation please join by computer audio at: <https://montereycty.zoom.us/j/99769079850>

**OR to participate by phone call any of these numbers below:**

- +1 669 900 6833 US (San Jose)
- +1 346 248 7799 US (Houston)
- +1 312 626 6799 US (Chicago)
- +1 929 205 6099 US (New York)
- +1 253 215 8782 US
- +1 301 715 8592 US

Enter this Meeting ID number: 997 6907 9850 when prompted. Please note there is no Participant Code, you will just press # again after the recording prompts you.

You will be placed in the meeting as an attendee; when you are ready to make a public comment if joined by computer audio please Raise your Hand; and by phone please push \*9 on your keypad.

**PLEASE NOTE: IF ALL BOARD MEMBERS ARE PRESENT IN PERSON, PUBLIC PARTICIPATION BY ZOOM IS FOR CONVENIENCE ONLY AND IS NOT REQUIRED BY LAW. IF THE ZOOM FEED IS LOST FOR ANY REASON, THE BOARD OF DIRECTORS MEETING MAY BE PAUSED WHILE A FIX IS ATTEMPTED BUT THE MEETING MAY CONTINUE AT THE DISCRETION OF THE CHAIRPERSON.**

4. If you choose not to attend the Board of Directors meeting but wish to make a comment on a specific agenda item, please submit your comment via email by 5:00 p.m. on the Friday before the meeting.. Please submit your comment to the Secretary of the Board at [WRAPubliccomment@co.monterey.ca.us](mailto:WRAPubliccomment@co.monterey.ca.us) In an effort to assist the Secretary in identifying the agenda item relating to your public comment please indicate in the Subject Line, the meeting body (i.e. Board of Directors Agenda) and item number (i.e. Item No. 10). Your comment will be placed into the record at the Board meeting.

**Participacion en Reuniones:**

**Puede asistir a la reunion de la Junta Directiva a traves de los siguientes metodos:**

- 1. Podar asistir personalmente a la reunion; o,**
- 2. Asistir por Zoom (informacion a continuacion), que observe la transmisión de la reunión de la Junta Directiva en vivo por [http://monterey.granicus.com/ViewPublisher.php?view\\_id=19](http://monterey.granicus.com/ViewPublisher.php?view_id=19) o <http://www.mgtvonline.com/>**
- 3. Para participar for ZOOM, por favor únase for audio de computadora por:  
[https://montereycty.zoom.us/j/997 6907 9850](https://montereycty.zoom.us/j/99769079850)**

**O para participar for teléfono, llame a culquiera de los números a continuación:**

- +1 669 900 6833 US (San Jose)**
- +1 346 248 7799 US (Houston)**
- +1 312 626 6799 US (Chicago)**
- +1 929 205 6099 US (New York)**
- +1 253 215 8782 US**
- +1 301 715 8592 US**

**Cuando se le solicite, ingrese este número de reunión: 997 6907 9850. Por favor tenga en cuenta que no hay código de participante, simplemente presione # nuevamente después de que la grabación se lo indique.**

**Se le colocará en la reunion como asistente; cuando desee hacer un comentario público si esta unido por la computadora utilice la opción de levantar la mano en el chat de la pantalla; o por teléfono presione \*9 en su teclado.**

**TENGA EN CUENTA: SI TODOS LOS MIEMBROS DE LA JUNTA ESTÁN PRESENTES EN PERSONA, LA PARTICIPACIÓN PÚBLICA DE ZOOM ES SOLO POR CONVENIENCIA Y NO ES REQUERIDA POR LA LEY. SI EL FEED DE ZOOM SE PIERDE POR CUALQUIER MOTIVO, LA REUNIÓN DE LA JUNTA DIRECTIVA PUEDE PAUSARSE MIENTRAS SE INTENTA UNA SOLUCIÓN, PERO LA REUNIÓN PUEDE CONTINUAR A DISCRECIÓN DEL PRESIDENTE.**

- 4. Si prefiere no asistir a la reunión de la Junta Directiva pero desea hacer un comentario sobre algún tema específico de la agenda, por favor envíe su comentario por correo electrónico antes de las 5:00 p.m. el Viernes antes de la reunion.. Envíe su comentario al Secretario de la junta al correo electronico [WRAPubliccomment@co.monterey.ca.us](mailto:WRAPubliccomment@co.monterey.ca.us) <mailto:WRAPubliccomment@co.monterey.ca.us> Para ayudar al Secretario a idenficar el**

artículo de la agenda relacionado con su comentario, por favor indique en la línea de asunto del correo electrónico el cuerpo de la reunión (es decir, la Agenda de la Junta Directiva) y el número de artículo (es decir, el Artículo No. 10). Su comentario se colocará en el registro de la reunión de esta Junta.

**NOTE: All agenda titles related to numbered agenda items are live web links. Click on the title to be directed to corresponding Board Report.**

**PUBLIC COMMENT: Members of the public may address comments to the Board concerning each agenda item. The timing of public comment shall be at the discretion of the Chair.**

**Call to Order at 12:00 P.M.**

The meeting was called to order at 12:03 p.m.

**Roll Call**

**Present:** Matt Simis, Deidre Sullivan (arrived at 12:05p.m.), Ken Ekelund, Mike Scattini (arrived 12:10p.m.), Jason Smith (arrived at 12:02 p.m.), John Baillie, Marvin Borzini  
**Absent:** Mike LeBarre, Mark Gonzalez

**Public Comments on Closed Session Items**

**None**

1. Closed Session under Government Code section 54950, relating to the following items:
  - a. Pursuant to Government Code section 54956.9(d)(2), the Board will confer with legal counsel regarding one matter of significant exposure to litigation.
  - b. Pursuant to Government Code Section 54956.9(d)(1), the Board will confer with legal counsel regarding existing litigation:
    1. *Nacimiento Regional Water Management Advisory Committee v. Monterey County Water Resources Agency, et al.* (San Luis Obispo Superior Case No. 19CVP-0010)
  - c. Pursuant to Government Code section 54957(b)(1), the Board will provide a performance evaluation for the General Manager.
  - d. Pursuant to Government Code section 54956.8, the Board will confer with real property negotiators:
    - Property: Recycled Industrial Wastewater
    - Agency Negotiator(s): Ara Azhderian, General Manager
    - Negotiating Parties: City of Salinas and Monterey One Water

Under Negotiation: Price and terms.

*Note: Continuance of Closed Session to be held at the conclusion of the Board's Regular Agenda, or at any other time during the course of the meeting announced by the Chairperson of the Board. The public may comment on Closed Session items prior to the Board's recess to Closed Session.*

**Recess to Closed Session**

**Reconvene Meeting at 1:00 P.M.**

The meeting reconvened at 1:10 p.m.

**Pledge of Allegiance**

**ADDITIONS AND CORRECTIONS BY CLERK: The Clerk of the Board will announce agenda corrections and proposed additions, which may acted on by the Board as provided in Sections 54954.2 of the California Government Code.**

**Public Comment**

None

**Presentations**

**Board of Directors Comments: Marvin Borzini, John Baillie, Jason Smith, Mike Scattini  
Public Comments: Bill Lipe (will also follow-up in writing), Nancy Isakson**

2. Summary of the Castroville Seawater Intrusion Project's 2023 Operational Season.  
(Staff Presenting: Peter Vannerus)

**Attachments:**     [CSIP Season Summary 2023](#)

**Consent Calendar**

Upon Motion by Director John Baillie and Second by Deidre Sullivan the Board approved the Consent Calendar.

**Ayes: Matt Simis, Deidre Sullivan, Ken Ekelund, Mike Scattini, Jason Smith, John Baille, Marvin Borzini**

**Noes: None**

**Absent: Mike Lebarre, Mark Gonzalez,**

**Abstained: None**

**Recused: None**

3. Approve the Action Minutes of January 16, 2024, and Special Board of Directors Meeting Action Minutes of January 24, 2024.

**Attachments:**     [Draft BOD Minutes January 16, 2024](#)  
                              [Draft SPECIAL BOD Minutes January 24, 2024](#)

4. Receive the Monterey County Water Resources Agency FY 2023-24 Financial Status Report through December 31, 2023. (Staff: Nan Kyung Kim)

**Attachments:**     [Board Report](#)  
                              [FY24 Financial Status Report thru Dec. 31, 2023](#)  
                              [Executed BO# 24-002 FY24 WRA Financial](#)

**Action Items**

5. Consider receiving the 2023 Annual Groundwater Level Contours and Cumulative Change Chart. (Staff Presenting: Guillermo Diaz Moreno)

**Attachments:**     [Board Report](#)  
                              [Attachment A: Annual 2023 Shallow](#)  
                              [Attachment B: Annual 2023 Deep](#)  
                              [Attachment C: Cumulative Changes 1944 - 2023](#)  
                              [Attachment D: Summary of Changes 2022 - 2023](#)  
                              [Board Order](#)  
                              [Executed BO# 24-003 Annual GWL Contours & Cumulative Change Chart](#)

**Upon Motion by Director Deidre Sullivan and Second by Jason Smith the Board received the 2023 Annual Groundwater Level Contours and Cumulative Change Chart.**

**Ayes: Matt Simis, Deidre Sullivan, Ken Ekelund, Mike Scattini, Jason Smith, John Baillie, Marvin Borzini**

**Noes: None**

**Abstained: None**

**Absent: Mike LeBarre, Mark Gonzalez**

6. Consider adoption of a resolution amending the Bylaws of the Monterey County Water Resources Agency Board of Directors concerning Board member participation on standing and advisory committees. (Staff Presenting: Ara Azhderian)

**Attachments:**     [Board Report](#)  
                              [MCWRA Bylaws proposed amendments \(clean\) REVISED](#)  
                              [MCWRA Bylaws proposed amendments \(redline\) REVISED](#)  
                              [Resolution](#)  
                              [Executed RESO #24-001 MCWRA Bylaws](#)  
                              [Executed MCWRA Bylaws 2.20.24](#)

**Upon Motion by Director Ken Ekelund and Second by Jason Smith the Board adopted a resolution amending the Bylaws of the Monterey County Water Resources Agency Board of Directors**

concerning Board member participation on standing and advisory committees.

**Ayes:** Matt Simis, Deidre Sullivan, Ken Ekelund, Mike Scattini, Jason Smith, John Baillie, Marvin Borzini

**Noes:** None

**Abstained:** None

**Absent:** Mike LeBarre, Mark Gonzalez

**Board of Directors Comments:** Ken Ekelund

**Public Comments:** None

7. Consider recommending the Monterey County Water Resources Agency Board of Directors to include funding for Interlake Tunnel Project development, in the recommended budget for fiscal-year 2024-2025. (Staff Presenting: Ara Azhderian)

**Attachments:** [Board Report](#)  
[Board Order](#)  
[Executed BO#24-004 Interlake Tunnel Project](#)

Upon Motion by Director Ken Ekelund and Second by Deidre Sullivan the Board Recommend to the Monterey County Water Resources Agency Board of Directors to include funding for Interlake Tunnel Project development, in the recommended budget for fiscal-year 2024-2025 OPTION 3: The Agency could budget \$350,000 from Fund 130 (Hydroelectric Funds) to support work proposed under Option 2 as well as certifying the Final Environmental Impact Report and finalizing the Agency's water rights change petitions. This funding represents a moderate level of effort by staff with some consulting technical and legal support.

**Ayes:** Matt Simis, Deidre Sullivan, Ken Ekelund, Mike Scattini, Jason Smith, John Baillie,

**Noes:** Marvin Borzini

**Abstained:** None

**Absent:** Mike LeBarre, Mark Gonzalez

**Board of Directors Comments:** Ken Ekelund, Marvin Borzini, John Baillie, Mike Scattini, Deidre Sullivan

**Public Comments:** Nancy Isakson, Christopher Bunn, Bill Lipe

### **Key Information and Calendar of Events**

8. February, March and April 2024 Calendars.

**Attachments:** [February 2024](#)  
[March 2024](#)  
[April 2024](#)

### **General Manager's Report**

**Board of Directors Comments:** Ken Ekelund

**Public Comments:** Thomas Virsik, Margie Kay

9.
  - Fiscal-Year Ending 2025 Budget Preparation Update

- GEMS Expansion
- Personnel Update
- Monterey One Reconciliation
- Dam Safety Project Funding
- Carmel River Flood Model Update Funding
- Association of California Water Agencies Update
- Other

**Attachments:**     [General Manager Memo](#)  
[Board of Director - Special Meeting GEMS Expansion Presentation](#)  
[WRA Planning Committee Presentation RE Financial Forecasting Model](#)  
[BOS Legislative Workshop WRA Priorities Fact Sheets](#)  
[DRAFT ACWA 2024 FAC Priorities](#)

### **Committee Reports**

10. Committee Agenda's and Cancellation Notices for January and February 2024:
- Special Water Resources Agency Board of Directors
  - Water Resources Agency Reservoir Operations Advisory Committee
  - Water Resources Agency Basin Management Advisory Committee
  - Water Resources Agency Personnel and Administration Committee
  - Water Resources Finance Committee
  - Water Resources Planning Committee
  - Joint Water Resources/Board of Supervisors Leadership Committee

**Attachments:**     [Final SPECIAL BOD MEETING Agenda January 24, 2024](#)  
[Final ResOps Agenda January 25, 2024](#)  
[Final BMAC Agenda February 7, 2024](#)  
[P&A Cancellation Notice February 2024](#)  
[Final Finance Agenda February 2, 2024](#)  
[Final Planning Agenda February 7, 2024](#)  
[Final SPECIAL BOD Agenda February 7, 2024](#)  
[JBL Cancellation Notice February 2024](#)

### **Information Items**

11. Reservoir Storage Release Update. (Staff: Peter Kwiek)

**Attachments:**     [Reservoir Storage Release Update](#)

12. Salinas Valley Water Conditions: Quarterly Update for the First Quarter of Water Year 2023-2024.  
(Staff: Rene Nunez, Guillermo Diaz Moreno, and Tamara Voss)

**Attachments:**     [Salinas Valley Water Conditions for the First Qtr. Water Yr 23-24](#)

13. Well Permit Application Summary. (Staff: Guillermo Diaz Moreno)

**Attachments:**     [Well Permit Application Summary](#)

**Correspondence**

**Board of Directors Comments: Deidre Sullivan**

**Public Comments: None**

14. 1. Letter dated January 23, 2024 to Governor Gavin Newsom, Ben Allen (Bond Authors), Susan Eggman (Bond Authors), Eduardo Garcia (Bond Authors), Carlos Villapudua (Bond Authors), Josh Becker (Budget Subcommittee Chair), Steve Bennett (Budget Subcommittee Chair) from ACWA, CMUA, California Alliance for Jobs, Irvine Ranch Water District, San Diego County Water Authority, Sweetwater Authority, Yuba Water Agency, EVMWD, El Dorado Irrigation District, United Water Conservation District, Sonoma Water, NCWA, Serrano Water District, Monterey County, Monterey County Water Resources Agency, The City of San Diego, Turlock Irrigation District, Northern California Power Agency, Valley Water, SAFCA  
RE: Dam Safety and Resilience Program/Legislative Bond Proposals
2. Letter dated February 2, 2024 to Majority Leader Charles Schumer, Republican Leader Mitch McConnell, Speaker of the House Mike Johnson, Democratic Leader Hakeem Jefferies from Agribusiness and Water Council Arizona, Animas - La Plata Water Conservancy District (Colorado), Central Arizona Irrigation and Drainage District, Colorado Ag Water Alliance Colorado River District, Columbia Basin Development League (WASHINGTON), Deschutes Basin Board of Control (OREGON) - Arnold Irrigation District - Central Oregon Irrigation District -North Unit Irrigation District -Ochoco Irrigation District -Swalley Irrigation District -Three Sisters Irrigation District -Tumalo Irrigation District -Lone Pine Irrigation District, East Columbia Basin Irrigation District (WASHINGTON), Elephant Butte Irrigation District (NEW MEXICO), Farmers Conservation Alliance, Family Farm Alliance, Family Water Alliance (CALIFORNIA), Farwell Irrigation District (NEBRASKA), Greenfields Irrigation District (MONTANA), Idaho Water Users Association, Kansas Bostwick Irrigation District (KANSAS), Kittitas Reclamation District (WASHINGTON), Klamath Water Users Association (OREGON), Iliff Irrigation District (COLORADO), Logan Irrigation District; Loup Basin Reclamation District (NEBRASKA), Maricopa-Stanfield Irrigation and Drainage District (ARIZONA), Milk River Joint Board of Control (MONTANA), Monterey County Farm Bureau (CALIFORNIA), Monterey County Water Resources Agency (CALIFORNIA), National Water Resources Association, New Magma Irrigation and Drainage District (ARIZONA), North Sterling Irrigation District (COLORADO), Orange Cove Irrigation District (CALIFORNIA), Oregon Farm Bureau, Oregon Water Resources Congress, Roza Irrigation District (WASHINGTON), Salt River Project (ARIZONA), San Carlos Irrigation and Drainage District (ARIZONA), San Luis & Delta-Mendota Water Authority (CALIFORNIA), Sargent Irrigation District (NEBRASKA), Solana Irrigation District (CALIFORNIA), South Columbia Basin Irrigation

District (WASHINGTON), Truckee-Carson Irrigation District (NEVADA), Turlock Irrigation District (CALIFORNIA), Washington State Potato Commission, Washington State Water Resources Association.

RE: 70 million for Watershed and Flood Prevention Operation Program

3. Letter dated February 1, 2024 to Honorable Alex Padilla, United States Senate from Sonia M. De La Rosa, County Administrative Officer RE: Support for the Low-Income Water Assistance Program (LIHWAP) Establishment Act

**Attachments:**     [1.23.24 LTR Coalition to Governor Newsom RE Dam Safety Funding](#)  
                              [2.2.24 LTR Re WFPO Funding FY24 Appropriations](#)  
                              [2.1.24 CAO LTR of Support for Padilla RE: LIHWAP Establishment Act](#)

**Board of Directors Comments**

Jason Smith, Ken Ekelund

**Adjournment**

The meeting adjourned at 2:33p.m.

# County of Monterey

*Board of Supervisors Chambers  
168 W. Alisal St 1st Flr,  
Salinas, CA 93901*



## Meeting Minutes

**Wednesday, February 7, 2024**

**12:00 PM**

**SPECIAL MEETING - GEMS Expansion**

### Water Resources Agency Board of Directors

*Mike LeBarre, Chair  
Matt Simis, Vice Chair  
Mark Gonzalez  
Deidre Sullivan  
Ken Ekelund  
Mike Scattini  
Jason Smith  
John Ballie  
Marvin Borzini*

**Participation in meetings:**

You may attend the Board of Directors meeting through the following methods:

1. You may attend in person
2. Attend via Zoom (info below),
3. For ZOOM participation please join by computer audio at:  
<https://montereycty.zoom.us/j/99769079850>

**OR to participate by phone call any of these numbers below:**

- +1 669 900 6833 US (San Jose)
- +1 346 248 7799 US (Houston)
- +1 312 626 6799 US (Chicago)
- +1 929 205 6099 US (New York)
- +1 253 215 8782 US
- +1 301 715 8592 US

**Enter this Meeting ID number: 997 6907 9850 when prompted. Please note there is no Participant Code, you will just press # again after the recording prompts you.**

You will be placed in the meeting as an attendee; when you are ready to make a public comment if joined by computer audio please Raise your Hand; and by phone please push \*9 on your keypad.

**PLEASE NOTE: IF ALL BOARD MEMBERS ARE PRESENT IN PERSON, PUBLIC PARTICIPATION BY ZOOM IS FOR CONVENIENCE ONLY AND IS NOT REQUIRED BY LAW. IF THE ZOOM FEED IS LOST FOR ANY REASON, THE BOARD OF DIRECTORS MEETING MAY BE PAUSED WHILE A FIX IS ATTEMPTED BUT THE MEETING MAY CONTINUE AT THE DISCRETION OF THE CHAIRPERSON.**

4. If you choose not to attend the Board of Directors meeting but wish to make a comment on a specific agenda item, please submit your comment via email by 5:00 p.m. on the Friday before the meeting.. Please submit your comment to the Secretary of the Board at [WRAPubliccomment@co.monterey.ca.us](mailto:WRAPubliccomment@co.monterey.ca.us) In an effort to assist the Secretary in identifying the agenda item relating to your public comment please indicate in the Subject Line, the meeting body (i.e. Board of Directors Agenda) and item number (i.e. Item No. 10). Your comment will be placed into the record at the Board meeting.

**Participacion en Reuniones:**

Puede asistir a la reunion de la Junta Directiva a traves de los siguientes metodos:

1. Podar asistir personalmente a la reunion; o,
2. Asistir por Zoom (informacion a continuacion),
3. Para participar for ZOOM, por favor únase for audio de computadora por:  
[https://montereycty.zoom.us/j/997 6907 9850](https://montereycty.zoom.us/j/99769079850)

O para participar for teléfono, llame a culquiera de los números a continuación:

- +1 669 900 6833 US (San Jose)
- +1 346 248 7799 US (Houston)
- +1 312 626 6799 US (Chicago)
- +1 929 205 6099 US (New York)
- +1 253 215 8782 US
- +1 301 715 8592 US

Cuando se le solicite, ingrese este número de reunión: 997 6907 9850. Por favor tenga en cuenta que no hay código de participante, simplemente presione # nuevamente después de que la grabación se lo indique.

Se le colocará en la reunion como asistente; cuando desee hacer un comentario público si esta unido por la computadora utilice la opción de levantar la mano en el chat de la pantalla; o por teléfono presione \*9 en su teclado.

**TENGA EN CUENTA: SI TODOS LOS MIEMBROS DE LA JUNTA ESTÁN PRESENTES EN PERSONA, LA PARTICIPACIÓN PÚBLICA DE ZOOM ES SOLO POR CONVENIENCIA Y NO ES REQUERIDA POR LA LEY. SI EL FEED DE ZOOM SE PIERDE POR CUALQUIER MOTIVO, LA REUNIÓN DE LA JUNTA DIRECTIVA PUEDE PAUSARSE MIENTRAS SE INTENTA UNA SOLUCIÓN, PERO LA REUNIÓN PUEDE CONTINUAR A DISCRECIÓN DEL PRESIDENTE.**

4. Si prefiere no asistir a la reunión de la Junta Directiva pero desea hacer un comentario sobre algún tema específico de la agenda, por favor envíe su comentario por correo electrónico antes de las 5:00 p.m. el Viernes antes de la reunion.. Envíe su comentario al Secretario de la junta al correo electronico [WRAPubliccomment@co.monterey.ca.us](mailto:WRAPubliccomment@co.monterey.ca.us) <mailto:WRAPubliccomment@co.monterey.ca.us> Para ayudar al Secretario a idenficar el artículo de la agenda relacionado con su comentario, por favor indique en la linea de asunto del correo electronico el cuerpo de la reunion (es decir, la Agenda de la Junta Directiva) y el número de artículo (es decir, el Artículo No. 10). Su comentario se colocará en el registro de la reunion de esta Junta.

**NOTE: All agenda titles related to numbered agenda items are live web links. Click on the title to be directed to corresponding Board Report.**

**PUBLIC COMMENT: Members of the public may address comments to the Board concerning each agenda item. The timing of public comment shall be at the discretion of the Chair.**

**Call to Order at 12:00 P.M.**

The meeting was called to order at 12:02pm.

**Roll Call**

**Present:** Mike Lebarre, Matt Simis, Mark Gonzalez, Deidre Sullivan, Ken Ekelund, Mike Scattini (arrived at 12:12pm), Jason Smith, John Baillie  
**Absent:** Marvin Borzini

**Public Comments on Closed Session Items**

None

1. Closed Session under Government Code section 54950, relating to the following items:
  - a. Pursuant to Government Code section 54956.9(d)(2), the Board will confer with legal counsel regarding one matter of significant exposure to litigation.

*Note: Continuance of Closed Session to be held at the conclusion of the Board's Regular Agenda, or at any other time during the course of the meeting announced by the Chairperson of the Board. The public may comment on Closed Session items prior to the Board's recess to Closed Session.*

**Recess to Closed Session**

**Reconvene Meeting at 1:00 P.M.**

The meeting reconvened at 1:03pm.

**Pledge of Allegiance**

**ADDITIONS AND CORRECTIONS BY CLERK: The Clerk of the Board will announce agenda corrections and proposed additions, which may acted on by the Board as provided in Sections 54954.2 of the California Government Code.**

**Public Comment**

None

**Action Items**

Upon Motion by Director Matt Simis and Second by Jason Smith the Board received and update on tghе Agency's Groundwater Extraction Management System and discuss options on how to expand that system consistent with the Sustainable Groundwater Sustainability Act requirements related to collecting and monitoring groundwater data; and provide directions to staff.

**Ayes:** Mike LeBarre, Matt Simis, Mark Gonzalez, Deidre Sullivan, Ken Ekelund, Mike Scattini, Jason Smith, John Baillie

**Noes:** None

**Absent:** Marvin Borzini

**Board of Directors Comments:** Deidre Sullivan, Mike LeBarre, Mark Gonzalez, Ken Ekelund, John Baillie, Jason Smith

**Public Comments:** Piret Harmon, Christopher Bunn, Thomas Virsik, Nancy Isakson

2. Consider receiving an update on the Agency’s Groundwater Extraction Management System and discuss options on how to expand that system consistent with the Sustainable Groundwater Sustainability Act requirements related to collecting and monitoring groundwater data; and provide direction to staff.

**Attachments:** [Board Report](#)  
[Exhibit A: Map of Expansion Areas](#)  
[Board Order](#)

**Board of Directors Comments**

None

**Adjournment**

The meeting adjourned at 1:51pm.



# County of Monterey

## Item No.5

### Board Report

Board of Supervisors  
Chambers  
168 W. Alisal St., 1st Floor  
Salinas, CA 93901

Legistar File Number: WRAG 24-042

March 18, 2024

**Introduced:** 3/12/2024

**Current Status:** Agenda Ready

**Version:** 1

**Matter Type:** WR General Agenda

Approve Amendment No. 2 of the Agreement for Professional Services with GEI Consultants, Inc, in the amount of \$70,000 for engineering design & project management services for storm damage repair design and implementation of the Nacimiento Dam Hydro-plant's South Access Road; and authorizing the General Manager to execute the amendment. (Staff: Mark Foxworthy)

#### RECOMMENDATION:

It is recommended that the Monterey County Water Resources Agency Board of Directors:

Approve Amendment No. 2 of the Agreement for Professional Services with GEI Consultants, Inc, in the amount of \$70,000 for engineering design & project management services for storm damage repair design and implementation of the Nacimiento Dam Hydro-plant's South Access Road; and authorize the General Manager to execute the amendment.

#### SUMMARY/DISCUSSION:

There are two access routes to the Nacimiento Dam's Hydro-plant. The primary Hydro-plant access route is the Low Flow Crossing near the Dam's spillway plunge pool. The secondary access route to Nacimiento Dam's Hydro-plant is called the Hydro-plant South Access Road. During high flow spillway releases, the Low Flow Crossing is not passable making the South Access Road the only vehicle access to the Hydro-plant.

During the January 2023 storms, the Hydro-plant's South Access Road suffered erosion damage at three locations and threatening the stability of the road embankment. FEMA reimbursement for repair of the South Access Road were applied for. FEMA has authorized reimbursement for needed and requested repairs.

Approval of Amendment No. 2 to the Services Agreement with GEI for design of South Access Road repairs plans, and generation of bid documents needed for release of an RFP and construction contract to implement repairs. FEMA deadline for implementation of repairs the access road is June 2024, 18 months after declaration of emergency. An extension request to the current FEMA implementation deadline will be applied for.

#### OTHER AGENCY INVOLVEMENT:

FEMA (reimbursement and contracting requirements).

County of San Luis Obispo-Building and Planning (grading permit)

#### FINANCING:

Reimbursement of Agency expenses has been authorized from FEMA.

Prepared by: Mark Foxworthy, Senior Water Resources Engineer (831) 755-8984

Approved by: Ara Azhderian, General Manager, (831) 755-4860

Attachments:

1. Amendment No. 2
2. Agreement for Professional Services
3. Amendment No. 1
4. Board Order



# County of Monterey

## Item No.5

### Board Report

Board of Supervisors  
Chambers  
168 W. Alisal St., 1st Floor  
Salinas, CA 93901

Legistar File Number: WRAG 24-042

March 18, 2024

**Introduced:** 3/12/2024

**Current Status:** Agenda Ready

**Version:** 1

**Matter Type:** WR General Agenda

Approve Amendment No. 2 of the Agreement for Professional Services with GEI Consultants, Inc, in the amount of \$70,000 for engineering design & project management services for storm damage repair design and implementation of the Nacimiento Dam Hydro-plant's South Access Road; and authorizing the General Manager to execute the amendment.

#### RECOMMENDATION:

It is recommended that the Monterey County Water Resources Agency Board of Directors:

Approve Amendment No. 2 of the Agreement for Professional Services with GEI Consultants, Inc, in the amount of \$70,000 for engineering design & project management services for storm damage repair design and implementation of the Nacimiento Dam Hydro-plant's South Access Road; and authorize the General Manager to execute the amendment.

#### SUMMARY/DISCUSSION:

There are two access routes to the Nacimiento Dam's Hydro-plant. The primary Hydro-plant access route is the Low Flow Crossing near the Dam's spillway plunge pool. The secondary access route to Nacimiento Dam's Hydro-plant is called the Hydro-plant South Access Road. During high flow spillway releases, the Low Flow Crossing is not passable making the South Access Road the only vehicle access to the Hydro-plant.

During the January 2023 storms, the Hydro-plant's South Access Road suffered erosion damage at three locations and threatening the stability of the road embankment. FEMA reimbursement for repair of the South Access Road were applied for. FEMA has authorized reimbursement for needed and requested repairs.

Approval of Amendment No. 2 to the Services Agreement with GEI for design of South Access Road repairs plans, and generation of bid documents needed for release of an RFP and construction contract to implement repairs. FEMA deadline for implementation of repairs the access road is June 2024, 18 months after declaration of emergency. An extension request to the current FEMA implementation deadline will be applied for.

#### OTHER AGENCY INVOLVEMENT:

FEMA (reimbursement and contracting requirements).

County of San Luis Obispo-Building and Planning (grading permit)

#### FINANCING:

Reimbursement of Agency expenses has been authorized from FEMA.

Prepared by: Mark Foxworthy, Senior Water Resources Engineer (831) 755-8984

Approved by: Ara Azhderian, General Manager, (831) 755-4860

Attachments:

1. Amendment No. 2
2. Agreement for Professional Services
3. Amendment No. 1
4. Board Order

**AMENDMENT NO. 2  
TO AGREEMENT BY AND BETWEEN  
MONTEREY COUNTY WATER RESOURCES AGENCY &  
GEI CONSULTANTS, INC.**

**THIS AMENDMENT NO. 2** is made to the PROFESSIONAL SERVICES AGREEMENT for the provision of Professional consulting services by and between **GEI CONSULTANTS, INC.**, hereinafter “CONTRACTOR”, and the Monterey County Water Resources Agency, a political subdivision of the State of California, hereinafter referred to as “Agency”.

**WHEREAS**, CONTRACTOR entered into an Agreement for Services with the Agency on January 1, 2023 (hereinafter, “Agreement”); and

**WHEREAS**, on February 13, 2023, the Parties entered into Amendment No. 1 to the Agreement, thereby amending the Agreement by adding \$170,000 for a total contract amount of \$370,000; and

**WHEREAS**, the Parties wish to amend the Agreement by including Exhibit D to the Scope of Work and with a dollar amount increase of \$70,000 not to exceed a total contract amount of \$440,000, to continue providing services identified in the Agreement; and

**NOW THEREFORE**, the Agency and CONTRACTOR hereby agree to amend the AGREEMENT in the following manner:

1. Amend Section 1, **“Employment of CONTRACTOR”** to read as follows:

Employment of CONTRACTOR. Agency hereby engages CONTRACTOR and CONTRACTOR hereby agrees to perform the services set forth in Exhibit A and Exhibit D, in conformity with the terms of this Agreement. CONTRACTOR will complete all work in accordance with the Scope of Work/Work Schedule set forth in Exhibit A and Exhibit D:

2. Amend Section 3, **“Payments to CONTRACTOR; maximum liability”**, to read as follows:

Payments to CONTRACTOR; maximum liability. Subject to the limitations set forth herein, Agency shall pay CONTRACTOR in accordance with the payment provisions set forth in Exhibit B - REVISED. The maximum amount payable to the contractor under this contract is Four Hundred Forty Thousand dollars (\$440,000).

Original Agreement	\$200,000
Amendment No. 1	\$170,000
<u>Amendment No. 2</u>	<u>\$70,000</u>
Not to exceed total:	\$440,000

3. All other terms and conditions of the Agreement remain unchanged and in full force.

4. A copy of this AMENDMENT NO. 2 shall be attached to the original AGREEMENT dated January 1, 2023.

**IN WITNESS WHEREOF**, the parties have executed this AMENDMENT NO. 2 on the day and year written below.

MONTEREY COUNTY WATER  
RESOURCES AGENCY

CONTRACTOR

\_\_\_\_\_  
General Manager

By: \_\_\_\_\_  
Signature of Chair, President, or  
Vice-President

Dated: \_\_\_\_\_

\_\_\_\_\_  
Printed Name and Title

*Approved as to Fiscal Provisions:*

Dated: \_\_\_\_\_

\_\_\_\_\_  
Deputy Auditor/Controller

By: \_\_\_\_\_  
(Signature of Secretary, Asst. Secretary, CFO,  
Treasurer or Asst. Treasurer)\*

Dated: \_\_\_\_\_

*Approved as to Liability Provisions:*

\_\_\_\_\_  
Printed Name and Title

\_\_\_\_\_  
Risk Management

Dated: \_\_\_\_\_

Dated: \_\_\_\_\_

*Approved as to Form:*

\_\_\_\_\_  
Assistant County Counsel

Dated: \_\_\_\_\_

\*INSTRUCTIONS: If CONTRACTOR is a corporation, including limited liability and non-profit corporations, the full legal name of the corporation shall be set forth above together with the signatures of two specified officers. If CONTRACTOR is a partnership, the name of the partnership shall be set forth above together with the signature of a partner who has authority to execute this Agreement on behalf of the partnership. If CONTRACTOR is contracting in an individual capacity, the individual shall set forth the name of the business, if any, and shall personally sign the Agreement.

**EXHIBIT B - REVISED**  
**Payment Provisions**

CONTRACTOR shall be compensated for the work as set forth in the Scope of Work and for other services as directed by the Agency on a Time and Materials basis in accordance with the following hourly labor rates:

DIRECT LABOR RATE SCHEDULE:

The Direct Labor Rate Schedule (Table 1) herein is effective beginning September 5, 2023. The labor hourly billing rate schedule and other direct costs chargeable to the work may be modified as agreed by Agency and Contractor after a 12-month period. Any agreed labor rate increase shall not exceed the 12-month San Francisco Bay Area CPI for the prior February. The parties shall agree to such modifications in writing as an Amendment to the Agreement.

Table 1. Direct Labor Rate Schedule GEI Consultants, Inc., Labor

<u>Category</u>	<u>Rate/Hour</u>
Principal Engineer (Gr. 8) .....	\$342
Engineering Support (Gr. 8) .....	\$342
Engineering Support (Gr. 7) .....	\$306
Engineering Support (Gr. 6) .....	\$257
Engineering Support (Gr. 5) .....	\$226
Engineering Support (Gr. 3) .....	\$171
Support Administrative .....	\$127

# Exhibit B - REVISED Payment Provisions

## Monterey County Water Resources Agency Labor and Direct Cost Estimate

### Nacimiento Hydroplant Secondary Access Road Repairs

MCWRA - Nacimiento PP Secondary Access Road

Task No.	Description	Labor Estimates														Total Estimate					
		Rettberg		Sansone		Fill		Velasquez		Meyers		Tognolini		Subconsultants						Admin	
		Hrs	\$342	Hrs	\$342	Hrs	\$306	Hrs	\$257	Hrs	\$226	Hrs	\$171	Hrs		Hrs	\$127	Hrs	Labor	Per Diem/ODC's	Total
1	<b>Review Project Details and Project Management</b>																10	\$2,774		\$2,774	
	Review Project Details and Coordinate Work	2	\$684			6	\$1,836									2	\$254	10	\$2,774		\$2,774
2	<b>Complete Development of Plans and Specifications for Construction Contract</b>																248	\$63,470	\$6,712	\$70,182	
	Completed Development of P&S for Construction Contract			8	\$2,736			26	\$6,682	80	\$18,080	124	\$21,204		\$2,600	8	\$1,016	246	\$52,318	\$5,362	\$57,680
	Perform Topographic Surveys and Establish Survey Control			2	\$684			2	\$514			2	\$342		\$9,000				\$10,540	\$1,350	\$11,890
	QC/QA Review					2	\$612											2	\$612		\$612
3	<b>Provide Engineering Services During Construction</b>																88	\$20,262	\$1,069	\$21,331	
	Review and Respond to RFIs, Submittals, Design Changes, etc.			4	\$1,368			8	\$2,056	20	\$4,520					8	\$1,016	40	\$8,960		\$8,960
	Provide On-Site Resident Engineer			2	\$684			2	\$514	42	\$9,492							46	\$10,690	\$1,069	\$11,759
	QC/QA Review					2	\$612											2	\$612		\$612
<b>HOURS Subtotal Tasks 1-3</b>		2		16		10		38		142		126			18		<b>346</b>				
<b>Total Tasks 1-3</b>			\$684		\$5,472		\$3,060		\$9,766		\$32,092		\$21,546		\$11,600		\$2,286		<b>\$86,506</b>	<b>\$7,781</b>	<b>\$94,287</b>

**Notes and Assumptions:**

**General**

- Labor hour and grade and task distribution is for budgeting purposes only. The actual labor and task distribution will be based on efficiently performing the work as ordered by MCWRA.
- Per diem is estimated at 10% of labor for field tasks and will comply with MCWRA travel policies and procedures.

**Task 1**

- Task 1 is for Project Administrator and Project Manager review of pertinent project documents for QC/QA oversight and processing of progress estimates.

**Task 2**

- Task 2 is anticipated for senior engineers for 40 hours (includes survey oversight), one project engineer for 80 hours, and one CAD/Design Engineer for 120 hours for preliminary and final drawings in coordination with MCWRA engineer(s).
- Task 2 includes 1 site visit for Construction Manager and Engineer with travel time from Oakland or Sacramento offices of GEI Consultants, Inc..
- Task 2 includes an Opinion of Probable Cost Estimate from the Design Engineer.
- Task 2 includes survey subconsultant for topographic surveys and setting control. Subconsultants will be marked up 15% per standard agreement with MCWRA.
- Task 2 includes estimating services from a qualified subconsultant to check and comment on the OPC estimate from the Design Engineer.

**Task 3**

- Task 3 Scope of Engineering Services During Construction is currently unknown but requested as possible service by MCWRA. Estimated costs are included and services will be performed only as approved by MCWRA.
- Task 3 assumes up to 8 total RFI reviews, submittal reviews, and design changes during construction.
- Task 3 per diem includes travel from Oakland or Sacramento offices of GEI Consultants, Inc., lodging, and meals. ESDC shifts are assumed to be three visits total, M-F, 8 hours per day plus travel time.

# Exhibit D - Scope of Work

Nacimiento Dam South Access Road Repair Design & Construction management.

**Task 1 – Review Project Details and Project Management – \$2,774**

Project Administrator and Project Manager review of pertinent project documents for QC/QA oversight and processing of progress estimates.

**Task 2 – Complete Development of Plans and Specifications for Construction Contract - \$70,182**

Complete development of P&S for construction contract, perform topographic surveys, and provide Opinion of Probable Cost estimate.

**Task 3 – Provide Engineering Services during Construction (Optional Task) – \$21,331**

Review and respond to RFIs, Submittals, Design Changes, etc. and provide part time on-site Resident Engineer during construction.

The total estimate including Optional Task 3 is **\$94,287**.

**MONTEREY COUNTY WATER RESOURCES AGENCY  
AGREEMENT FOR PROFESSIONAL SERVICES  
WITH SURVEYORS, ARCHITECTS, ENGINEERS AND/OR DESIGN  
PROFESSIONALS**

This is an agreement (“Agreement”) between the Monterey County Water Resources Agency, hereinafter called "Agency," and GEI Consultants, Inc., a Massachusetts Corporation located at 180 Grand Avenue, Suite 950, Oakland CA 94612 hereinafter called "CONTRACTOR".

In consideration of the mutual covenants and conditions set forth in this Agreement, the parties agree as follows:

1. Employment of CONTRACTOR. Agency hereby engages CONTRACTOR and CONTRACTOR hereby agrees to perform the services set forth in Exhibit A, in conformity with the terms of this Agreement. CONTRACTOR will complete all work in accordance with the **Scope of Work/Work Schedule set forth in Exhibit A:**

- (a) The scope of work is briefly described and outlined as follows:  
Engineering, construction, and environmental services related to 2023 storm repair work at Agency facilities.
- (b) The CONTRACTOR shall perform its services under this agreement in accordance with usual and customary care and with generally accepted practices in effect at the time the services are rendered. The CONTRACTOR and its agents and employees performing work hereunder are specially trained, experienced, competent, and appropriately licensed to perform the work and deliver the services required by this Agreement.
- (c) CONTRACTOR, its agents and employees shall perform all work in a safe and skillful manner and in compliance with all applicable laws and regulations. All work performed under this Agreement that is required by law to be performed or supervised by licensed personnel shall be performed in accordance with such licensing requirements.
- (d) CONTRACTOR shall furnish, at its own expense, all materials and equipment necessary to carry out the terms of this Agreement, except as otherwise provided herein. CONTRACTOR shall not use Agency premises, property (including equipment, instruments, or supplies) or personnel for any purpose other than in the performance of its obligations hereunder.

2. Term of Agreement. The term of this Agreement shall begin on January 1, 2023 by CONTRACTOR and Agency, and will terminate on December 31, 2024, unless earlier terminated as provided herein.

3. Payments to CONTRACTOR; maximum liability. Subject to the limitations set forth herein, Agency shall pay to CONTRACTOR in accordance with the fee schedule set forth in Exhibit B. The maximum amount payable to CONTRACTOR under this contract is two hundred thousand dollars.

(\$ 200,000.00).

4. Monthly Invoices by CONTRACTOR; Payment.

- (a) CONTRACTOR shall submit to Agency an invoice, in a format approved by Agency, setting forth the amounts claimed by CONTRACTOR, together with an itemized basis for such amounts, and setting forth such other pertinent information Agency may require. CONTRACTOR shall submit such invoice monthly or as agreed by Agency, but in no event shall such invoice be submitted later than 30 days after completion of CONTRACTOR's work hereunder. Agency shall certify the claim if it complies with this contract and shall promptly submit such claim to the Monterey County Auditor-Controller, who shall pay the certified amount within 30 days after receiving the invoice certified by Agency. It is understood and agreed that CONTRACTOR shall complete all work described in Exhibit A for an amount not exceeding that set forth above, notwithstanding CONTRACTOR's submission of periodic invoices.
- (b) CONTRACTOR agrees that Agency may withhold five percent (5%) of the amount requested by CONTRACTOR from any progress payment, until such time as all goods and services are received in a manner and form acceptable to Agency.
- (c) If, as of the date of execution of this Agreement, CONTRACTOR has already received payment from Agency for work which is the subject of this Agreement, such amounts shall be deemed to have been paid under this Agreement and shall be counted toward Agency's maximum liability set forth above.
- (d) CONTRACTOR shall not be reimbursed for travel expenses unless expressly approved in writing in accordance with this Agreement.

5. Indemnification

- 5.1 For purposes of the following indemnification provisions ("Indemnification Agreement"), "design professional" has the same meaning as set forth in California Civil Code section 2782.8. If any term, provision or application of this Indemnification Agreement is found to be invalid, in violation of public policy or unenforceable to any extent, such finding shall not invalidate any other term or provision of this Indemnification Agreement and such other terms and provisions shall continue in full

force and effect. If there is any conflict between the terms, provisions or application of this Indemnification Agreement and the provisions of California Civil Code Sections 2782 or 2782.8, the broadest indemnity protection for the COUNTY under this Indemnity Agreement that is permitted by law shall be provided by CONTRACTOR.

5.2 Indemnification for Design Professional Services Claims: CONTRACTOR shall indemnify, defend and hold harmless COUNTY, its governing board, directors, officers, employees, and agents against any claims that arise out of, or pertain to, or relate to the negligence, recklessness, or willful misconduct of the CONTRACTOR, its employees, subCONTRACTORS, and agents in the performance of design professional services under this Agreement, excepting only liability arising from the sole negligence, active negligence or willful misconduct of COUNTY, or defect in a design furnished by COUNTY, but in no event shall the amount of such CONTRACTOR's liability exceed such CONTRACTOR's proportionate percentage of fault as determined by a court, arbitrator or mediator, or as set out in a settlement agreement. In the event one or more defendants to any action involving such claim or claims against COUNTY is unable to pay its share of defense costs due to bankruptcy or dissolution of the business, such CONTRACTOR shall meet and confer with the other parties to such action regarding unpaid defense costs.

5.3 Indemnification for All Other Claims or Loss:  
For any claim, loss, injury, damage, expense or liability other than claims arising out of the CONTRACTOR's performance of design professional services under this Agreement, CONTRACTOR shall indemnify, defend and hold harmless COUNTY, its governing board, directors, officers, employees, and agents against any claim for loss, injury, damage, expense or liability resulting from or alleging injury to or death of any person or loss of use of or damage to property, arising from or related to the performance of services under this Agreement by CONTRACTOR, its employees, subCONTRACTORS or agents, excepting only liability arising from the sole negligence, active negligence or willful misconduct of the COUNTY, or defect in a design furnished by the COUNTY.

## 6. Insurance.

6.1 Evidence of Coverage:  
Prior to commencement of this Agreement, the CONTRACTOR shall provide a "Certificate of Insurance" certifying that coverage as required herein has been obtained. Individual endorsements executed by the insurance carrier shall accompany the certificate. In addition the CONTRACTOR upon request shall provide a certified copy of the policy or policies.

This verification of coverage shall be sent to the Agency's Contact, unless otherwise directed. The CONTRACTOR shall not receive a "Notice to Proceed" with the work under this Agreement until it has obtained all insurance required and such, insurance has been approved by the Agency. This approval of insurance shall

neither relieve nor decrease the liability of the CONTRACTOR.

6.2 Qualifying Insurers:

All coverage's, except surety, shall be issued by companies which hold a current policy holder's alphabetic and financial size category rating of not less than A-VII, according to the current Best's Key Rating Guide or a company of equal financial stability that is approved by the County's Purchasing Manager.

6.3 Insurance Coverage Requirements:

Without limiting CONTRACTOR's duty to indemnify, CONTRACTOR shall maintain in effect throughout the term of this Agreement a policy or policies of insurance with the following minimum limits of liability:

Commercial general liability insurance, including but not limited to premises and operations, including coverage for Bodily Injury and Property Damage, Personal Injury, Contractual Liability, Broad form Property Damage, Independent CONTRACTORS, Products and Completed Operations, with a combined single limit for Bodily Injury and Property Damage of not less than \$1,000,000 per occurrence.

Exemption/Modification (Justification attached; subject to approval).

Business automobile liability insurance, covering all motor vehicles, including owned, leased, non-owned, and hired vehicles, used in providing services under this Agreement, with a combined single limit for Bodily Injury and Property Damage of not less than \$1,000,000 per occurrence.

Exemption/Modification (Justification attached; subject to approval).

Workers' Compensation Insurance, if CONTRACTOR employs others in the performance of this Agreement, in accordance with California Labor Code section 3700 and with Employer's Liability limits not less than \$1,000,000 each person, \$1,000,000 each accident and \$1,000,000 each disease.

Exemption/Modification (Justification attached; subject to approval).

Professional liability insurance, if required for the professional services being provided, (e.g., those persons authorized by a license to engage in a business or profession regulated by the California Business and Professions Code), in the amount of not less than \$1,000,000 per claim and \$2,000,000 in the aggregate, to cover liability for malpractice or errors or omissions made in the course of rendering professional services. If professional liability insurance is written on a "claims-made" basis rather than an occurrence basis, the CONTRACTOR shall, upon the expiration or earlier termination of this Agreement, obtain extended reporting coverage ("tail coverage") with the same liability limits. Any such tail coverage shall continue for at least three years following the expiration or earlier termination of this Agreement.

Exemption/Modification (Justification attached; subject to approval).

#### 6.4 Other Insurance Requirements.

All insurance required by this Agreement shall be with a company acceptable to the Agency and issued and executed by an admitted insurer authorized to transact Insurance business in the State of California. Unless otherwise specified by this Agreement, all such insurance shall be written on an occurrence basis, or, if the policy is not written on an occurrence basis, such policy with the coverage required herein shall continue in effect for a period of three years following the date CONTRACTOR completes its performance of services under this Agreement.

Each liability policy shall provide that the Agency shall be given notice in writing at least thirty days in advance of any endorsed reduction in coverage or limit, cancellation, or intended non-renewal thereof. Each policy shall provide coverage for CONTRACTOR and additional insureds with respect to claims arising from each subCONTRACTOR, if any, performing work under this Agreement, or be accompanied by a certificate of insurance from each subCONTRACTOR showing each subCONTRACTOR has identical insurance coverage to the above requirements.

Commercial general liability and automobile liability policies shall provide an endorsement naming the Monterey County Water Resources Agency and the County of Monterey, their officers, agents, and employees as Additional Insureds with respect to liability arising out of the CONTRACTOR'S work, including ongoing and completed operations, and shall further provide that such insurance is primary insurance to any insurance or self-insurance maintained by the County and that the insurance of the Additional Insureds shall not be called upon to contribute to a loss covered by the CONTRACTOR'S insurance. The required endorsement form for Commercial General Liability Additional Insured is **ISO Form CG 20 10 11-85 or CG 20 10 10 01 in tandem with CG 20 37 10 01 (2000). The required endorsement form for Automobile Additional Insured endorsement is **ISO Form CA 20 48 02 99.****

Prior to the execution of this Agreement by the Agency, CONTRACTOR shall file certificates of insurance with the Agency's contract administrator, showing that the CONTRACTOR has in effect the insurance required by this Agreement. The CONTRACTOR shall file a new or amended certificate of insurance within five calendar days after any change is made in any insurance policy, which would alter the information on the certificate then on file. Acceptance or approval of insurance shall in no way modify or change the indemnification clause in this Agreement, which shall continue in full force and effect.

CONTRACTOR shall at all times during the term of this Agreement maintain in force the insurance coverage required under this Agreement and shall send, without demand by Agency, annual certificates to Agency's Contract Administrator. If the certificate is not received by the expiration date, Agency shall notify CONTRACTOR and CONTRACTOR shall have five calendar days to send in

the certificate, evidencing no lapse in coverage during the interim. Failure by CONTRACTOR to maintain such insurance is a default of this Agreement, which entitles Agency, at its sole discretion, to terminate this Agreement immediately.

7. Maintenance of Records. CONTRACTOR shall prepare, maintain and preserve all reports and records that may be required by federal, State, and local rules and regulations relating to services performed under this Agreement. CONTRACTOR shall retain all such records for at least five years from the date of final payment, or until any litigation relating to this Agreement is concluded, whichever is later.
8. Right to Audit at Any Time. Agency officials shall have the right, at any time during regular working hours and on reasonable advance notice, to examine, monitor and audit all work performed and all records, documents, conditions, activities and procedures of CONTRACTOR or its subCONTRACTORS relating to this Agreement. Government Code Section 8546.7 provides that an audit by the State Auditor General may be performed up to three years after the final payment under any contract involving the expenditure of public funds in excess of \$10,000.
9. Confidentiality; Return of Records. CONTRACTOR and its officers, employees, agents, and subCONTRACTORS shall comply with all federal, State and local laws providing for the confidentiality of records and other information. To the extent permitted by applicable law and regulations, CONTRACTOR shall maintain confidentiality with respect to Agency's well database and other water use data.

CONTRACTOR shall not disclose any confidential information received from Agency or prepared in connection with the performance of this Agreement without the express permission of Agency. CONTRACTOR shall promptly transmit to Agency all requests for disclosure of any such confidential information. CONTRACTOR shall not use any confidential information gained through the performance of this Agreement except for the purpose of carrying out CONTRACTOR's obligations hereunder. When this Agreement expires or terminates, CONTRACTOR shall return to Agency all records, which CONTRACTOR utilized or received, from Agency to perform services under this Agreement.

10. Termination. Either party may terminate this Agreement by giving written notice of termination to the other party at least thirty (30) days prior to the effective date of termination, which date shall be specified in any such notice. In the event of such termination, the amount payable hereunder shall be reduced in proportion to the services provided prior to the effective date of termination. Agency may terminate this Agreement at any time for good cause effective immediately upon written notice to CONTRACTOR. "Good cause" includes, without limitation, the failure of CONTRACTOR to perform the required services at the time and in the manner provided herein. If Agency terminates this Agreement for good cause, Agency may be relieved of the payment of any consideration to CONTRACTOR, and Agency may proceed with the work in any manner, which it deems proper. Costs incurred by Agency thereby shall be

deducted from any sum due CONTRACTOR.

11. Amendments and Modifications. No modification or amendment of this agreement shall be valid unless it is set forth in writing and executed by the parties.
12. Non-Discrimination. Throughout the performance of this Agreement, CONTRACTOR will not unlawfully discriminate against any person because of race, color, religion, gender, national origin, ancestry, physical disability, medical condition, marital status, age older than 40, or sexual orientation, gender identity or any other status protected under federal, state or local law, either in CONTRACTOR's employment practices or in the furnishing of services to recipients. CONTRACTOR shall ensure that the evaluation and treatment of its employees and applicants for employment and all persons receiving and requesting services are free of such discrimination. CONTRACTOR shall comply fully with all federal, State and local laws and regulations which prohibit discrimination. The provision of services primarily or exclusively to any target population designated herein shall not be deemed prohibited discrimination.
13. Independent Contractor. In its performance under this Agreement, CONTRACTOR is at all times acting and performing as an independent CONTRACTOR and not an employee of Agency. No offer or obligation of employment with Agency is intended in any manner, and CONTRACTOR shall not become entitled by virtue of this Agreement to receive from Agency any form of benefits accorded to employees including without limitation leave time, health insurance, workers compensation coverage, disability benefits, and retirement contributions. CONTRACTOR shall be solely liable for and obligated to pay directly all applicable taxes, including without limitation federal and State income taxes and social security arising out of CONTRACTOR's performance of this Agreement. In connection therewith, CONTRACTOR shall defend, indemnify, and hold harmless Agency from any and all liability, which Agency may incur because of CONTRACTOR's failure to make such payments.
14. Delegation of Duties; Subcontracting. CONTRACTOR is engaged by Agency for its unique qualifications and abilities. CONTRACTOR may not, therefore, delegate any of its basic duties under this Agreement, except to the extent that delegation to CONTRACTOR's employees is contemplated herein. No work shall be subcontracted without the written consent of Agency, except as provided in this Agreement or its attachments. Notwithstanding any subcontract, CONTRACTOR shall continue to be liable to Agency for the performance of all work hereunder. CONTRACTOR shall not assign, sell, mortgage or otherwise transfer its interest or obligations in this Agreement without Agency's prior written consent.
15. Agency's Rights in Work Product. All original materials prepared by CONTRACTOR in connection with its work hereunder -- including but not limited to computer codes, customized computer routines developed using proprietary or commercial software packages, reports, documents, maps, graphs, charts, photographs and photographic negatives -- shall be the property of Agency and shall be delivered to Agency prior to final payment. CONTRACTOR may utilize any existing materials developed by

CONTRACTOR prior to commencement of work under this Agreement, which materials shall remain the property of CONTRACTOR.

16. Compliance with Terms of Federal or State Grant. If any part of this Agreement has been or will be funded pursuant to a grant from the federal or State government in which Agency is the grantee, CONTRACTOR shall comply with all provisions of such grant applicable to CONTRACTOR's work hereunder, and said provisions shall be deemed a part of this Agreement as though fully set forth herein.
17. Conflict of Interest. CONTRACTOR warrants that it presently has no interest and shall not acquire any interest during the term of this Agreement, which would directly or indirectly conflict in any manner or to any degree with its full and complete performance of all services under this Agreement.
18. Governing Laws. This Agreement is entered into in the County of Monterey, State of California, and shall be construed and enforced in accordance with the laws of the State of California. The parties hereby agree that the County of Monterey shall be the proper venue for any dispute arising hereunder.
19. Compliance with Applicable Law. The parties shall comply with all applicable federal, state, and local laws and regulations in performing this Agreement.
20. Construction of Agreement. The parties agree that each party has fully participated in the review and revision of this Agreement and that any rule of construction to the effect that ambiguities are to be resolved against the drafting party shall not apply in the interpretation of this Agreement or any exhibit or amendment. To that end, it is understood and agreed that this Agreement has been arrived at through negotiation, and that neither party is to be deemed the party which prepared this Agreement within the meaning of Civil Code Section 1654. Section and paragraph headings appearing herein are for convenience only and shall not be used to interpret the terms of this Agreement.
21. Waiver. Any waiver of any term or condition hereof must be in writing. No such waiver shall be construed as a waiver of any other term or condition herein.
22. Successors and Assigns. This Agreement and all rights, privileges, duties and obligations hereunder, to the extent assignable or delegable, shall be binding upon and inure to the benefit of the parties and their respective successors, permitted assigns and heirs.
23. Contractor. The term "CONTRACTOR" as used in this Agreement includes CONTRACTOR's officers, agents, and employees acting on Contractor's behalf in the performance of this Agreement.
24. Interpretation of Conflicting Provisions. In the event of any conflict or inconsistency between the provisions of this Agreement and the Provisions of any exhibit or other attachment to this Agreement, the provisions of this Agreement shall prevail and control.

25. Time is of the Essence. The parties mutually acknowledge and agree that time is of the essence with respect to every provision hereof in which time is an element. No extension of time for performance of any obligation or act shall be deemed an extension of time for performance of any other obligation or act, nor shall any such extension create a precedent for any further or future extension.

26. Contract Administrators.

CONTRACTOR's designated principal responsible for administering  
CONTRACTOR's work under this Agreement shall be

Mr. William Rettberg

Agency's designated administrator of this Agreement shall be

Mr. Chris Moss

27. Notices. Notices required under this Agreement shall be delivered personally or by electronic facsimile, or by first class or certified mail with postage prepaid. Notice shall be deemed effective upon personal delivery or facsimile transmission, or on the third day after deposit with the U.S. Postal Service. CONTRACTOR shall give Agency prompt notice of any change of address. Unless otherwise changed according to these notice provisions, notices shall be addressed as follows:

<b>TO AGENCY</b>	<b>TO CONTRACTOR</b>
Name: Mr. Chris Moss	Name: Mr. William Rettberg
Address: 1441 Schilling Place - N. Bldg, Salinas CA 93901	Address: 180 Grand Avenue, Suite 950, Oakland CA 94612
Telephone: 831-755-4860	Telephone: 510-910-2201
Fax: 831-424-3579	Fax: -----
E-Mail: mosscc@co.monterey.ca.us	E-Mail: wrettberg@geiconsultants.com

28. Federal Emergency Management Agency ("FEMA") Contract Provisions. The FEMA Standard Provisions and Funding Requirements contract provisions attached in Exhibit C are hereby incorporated by this reference.

29. Non-exclusive Agreement. This Agreement is non-exclusive and both parties reserve the right to contract with other entities for the same or similar services.

30. Execution of Agreement. Any individual executing this Agreement on behalf of an entity represents and warrants that he or she has the requisite authority to enter into this Agreement on behalf of such entity and to bind the entity to the terms and conditions hereof. This Agreement may be executed in two or more counterparts, each of which shall be deemed an original, but all of which together shall constitute one and the same agreement.

31. Exhibits. The following Exhibits are attached hereto and incorporated by reference:

Exhibit A - Scope of Work/ Work Schedule

Exhibit B - Payment Provisions

Exhibit C - FEMA Standard Provisions and Funding Requirements

32. Entire Agreement --As of the effective date of this Agreement, this document, including all exhibits hereto, constitutes the entire agreement between the parties, and supersedes any and all prior written or oral negotiations and representations between the parties concerning all matters relating to the subject of this Agreement.

**MONTEREY COUNTY WATER RESOURCES AGENCY  
AGREEMENT FOR PROFESSIONAL SERVICES  
WITH SURVEYORS, ARCHITECTS, ENGINEERS AND/OR DESIGN  
PROFESSIONALS**

IN WITNESS WHEREOF, AGENCY and CONTRACTOR execute this agreement as follows:

**MONTEREY COUNTY WATER  
RESOURCES AGENCY:**

**CONTRACTOR:**

BY:   
DocuSigned by:  
631A724C33274DD...

BY: 

Lew Bauman  
Interim General Manager

Type Name: William Rettberg

Title: Senior Vice President

Date: 2/13/2023 | 8:27 AM PST

Date: 2/10/2023

BY: 

Type Name: Mark Freitas

Title: Vice President

Date: 2/10/2023

\* INSTRUCTIONS: If CONTRACTOR is a corporation (including limited liability and nonprofit corporations), the full legal name of the corporation shall be set forth together with the signatures of two specified officers. If CONTRACTOR is a partnership, the name of the partnership shall be set forth together with the signature of a partner with authority to execute this Agreement on behalf of the partnership. If CONTRACTOR is contracting in an individual capacity, the individual shall set forth the name of his or her business, if any, and shall personally sign the Agreement.

\*\*\*\*\*

Approved as to form <sup>1</sup>:

Approved as to fiscal provisions:

DocuSigned by:  
*Kelly L. Doulon*  
22D690CA05A940B...  
Assistant County Counsel

DocuSigned by:  
*Juan Pablo Lopez*  
A59152E49ADC476...  
Administrative Analyst

Dated: 2/10/2023 | 1:30 PM PST

Dated: 2/10/2023 | 4:46 PM PST

County Council – Risk Manager:

DocuSigned by:  
*Jennifer Forsyth*  
4E7E657875454AE...  
Auditor-Controller <sup>2</sup>:

Dated: \_\_\_\_\_

Dated: 2/10/2023 | 4:41 PM PST

<sup>1</sup> Approval by County Council is required, and/or when legal services are rendered

<sup>2</sup> Approval by Auditor-Controller is required

# EXHIBIT A

## SCOPE OF WORK / WORK SCHEDULE

### NACIMIENTO DAM SPILLWAY PLUNGE POOL REPAIR AND PROTECTIVE MEASURES PROJECT

Storm events during January 2023 resulted in the rapid filling of Nacimiento reservoir requiring spillway discharges up to approximately 3,000 cfs causing new erosion along the left plunge pool bank. With the potential for additional large storm events this winter, further spillway discharges could further erode plunge pool banks, including potential erosion towards the left side of the spillway along the highly erodible Monterey Formation bank material. If left bank erosion of the Monterey Formation encroaches upon the spillway, impacts could create spillway instability and a dam safety concern. Rock protection along the left bank would help stabilize the area and help prevent future erosion towards the spillway, and towards an existing PG&E power pole located on the left bank. Rock protection in two unprotected areas on the right bank would also help stabilize the right bank slopes, helping prevent future erosion towards the toe of Nacimiento Dam.

GEI Consultants, Inc. (Contractor) will perform the services below in support of repair and protective measures installation. Payment shall be in accordance with Exhibit B.

#### 1. ENGINEERING SERVICES

Design of emergency repair and protective measures.

**Deliverables:** Technical Memorandum, drawings, specifications, cost estimate, and estimated construction schedule.

#### 2. CONSTRUCTION SERVICES

Services during construction of emergency repair and protective measures, which may include but are not limited to, onsite construction inspection, construction progress photography, review and approval of daily contractor work report, weekly construction progress meeting coordination, attendance and meeting minutes preparation, weekly construction progress report, contractor change order preparation, field order preparation, substantial completion inspection, punch list development, final inspection, construction contract invoice payment review and recommendation, after-action report preparation for submittal to State and Federal agencies, and record keeping necessary to comply with construction contract and project permit requirements.

#### 3. ENVIRONMENTAL SERVICES

Perform environmental services which may include but is not limited to, monitoring, reporting, project mitigation plan preparation, project mitigation installation, and other activities necessary to comply with project permits and applicable regulations.

#### 4. PROJECT MANAGEMENT ASSISTANCE

Assist Agency with project management, coordination of personnel and activities necessary to complete Engineering Services, Construction Services and Environmental Services.

**GENERAL ENGINEERING SERVICES**

Upon request of Agency, Contractor will perform services for Agency owned facilities on an as needed basis. For such services, Agency will provide a Scope of Work, Schedule, and deliverables in writing, and agreed to in writing by Contractor (email will suffice for this purpose). Services may include, but are not limited to surveying, engineering, geotechnical services, construction management, inspection, environmental and permitting services. Subcontractors shall be approved by the Agency. Payment shall be in accordance with Exhibit B.

**WORK SCHEDULE**

Work schedule shall be determined by Agency in consultation with Contractor.

## EXHIBIT B

### PAYMENT PROVISIONS

#### **PAYMENT:**

For the Scope of Work described in Exhibit A, Agency shall pay Contractor on a time and expense basis an amount not to exceed \$200,000. Payable costs shall be the sum of direct labor costs, other direct costs and sub-consultant mark-up as defined below.

**Direct Labor Costs:** Are the hourly billing rate, per the Direct Labor Rate Schedules herein, times the number of hours worked by the personnel. Environmental services billing rates are shown in Table 1. All other labor billing rates are shown in Table 2.

**Other Direct Costs:** Other Direct Costs are identifiable costs necessarily incurred to complete the Scope of Work. Such costs include, but are not limited to, travel and subsistence expenses, document reproduction costs, postal, and materials costs. Expenses shall be accounted for in each invoice by submittal of receipts for such costs and a description of their necessity. Monterey County Travel Policy requires overnight lodging, meals, and incidentals be billed at U.S. General Services Administration (GSA) rates, no mark-up; mileage is billable at IRS allowable rate at time of travel, no mark-up. Non-Travel Policy costs may be marked-up 10%.

**Sub-Contractor Mark-up** is the percentage multiplier designated for each sub-Contractor times the sum of sub-Contractor direct labor and other direct charges. All sub-Contractor mark-up multipliers shall not exceed 1.10 (10% mark-up).

#### **DIRECT LABOR RATE SCHEDULE:**

The Direct Labor Rate Schedules (Tables 1 and 2) herein are effective beginning January 1, 2023. The hourly billing rate schedule and other direct costs chargeable to the work may be modified as agreed by Agency and Contractor after a 12-month period. Any agreed labor rate increase shall not exceed the 12-month San Francisco Bay Area CPI for the prior February. The parties shall agree to such modifications in writing as an Amendment to the Agreement.

**Table 1. Environmental Services Labor Rate Schedule**

<u>Personnel Category</u>	<i>Hourly Billing Rate</i> \$ per hour
Staff Professional – Grade 1	\$ 100
Staff Professional – Grade 2	\$ 118
Project Professional – Grade 3	\$ 131
Project Professional – Grade 4	\$ 159
Senior Professional – Grade 5	\$ 182
Senior Professional – Grade 6	\$ 208 - \$ 228
Senior Professional – Grade 7	\$ 269
Senior Consultant – Grade 8	\$ 299 - \$ 309
Senior Consultant – Grade 9	\$ 311
Senior Principal – Grade 10	\$ 312
-----	
Senior Drafter and Designer	\$ 161
Drafter / Designer and Senior Technician	\$ 131
Field Professional	\$ 119
Technician, Word Processor, Administrative Staff	\$ 94
<u>Office Aide</u>	<u>\$ 93</u>

**Table 2. All Other Labor Rate Schedule**

<u>Personnel Category</u>	<i>Hourly Billing Rate</i> \$ per hour
Staff Professional – Grade 1	\$ 141
Staff Professional – Grade 2	\$ 156
Project Professional – Grade 3	\$ 171
Project Professional – Grade 4	\$ 191
Senior Professional – Grade 5	\$ 226
Senior Professional – Grade 6	\$ 257
Senior Professional – Grade 7	\$ 306
Senior Consultant – Grade 8	\$ 342
Senior Consultant – Grade 9	\$ 417
Senior Principal – Grade 10	\$ 417
-----	
Senior Drafter and Designer	\$ 171
Drafter / Designer and Senior Technician	\$ 156
Field Professional	\$ 128
Technician, Word Processor, Administrative Staff	\$ 127
Office Aide	\$ 99

**INVOICES:**

Invoices may be submitted monthly. Invoices shall include the direct labor costs by individual and task, showing the individual's hours charged, hourly rate and total amount charged to each task. Other direct charges shall be added to the sum of the direct labor costs by task. Other direct charges shall be accounted for in each invoice by submittal of receipts for such costs and description of their necessity. Percent of task completion shall be included on each invoice.

**NOTIFICATION:**

When, during performance of the work, Contractor incurs 75 percent of the total task cost allotted to a task, Contractor shall so notify the Agency to that effect. If Consultant has reason to believe that the costs which it expects to incur to finish the task, when added to the costs previously incurred, will exceed the total task cost, Contractor shall so notify the Agency to that effect. The notice shall state: (1) the estimated amount of additional funds required to complete the task; (2) justification for the need for additional funds; and (3) the estimated date Contractor expects its total costs incurred to meet the total task cost.

## **EXHIBIT C**

### **FEMA STANDARD PROVISIONS AND FUNDING REQUIREMENTS**

The Agreement may be funded in part by the federal grant funding received by the Monterey County Water Resources Agency (“AGENCY”) from the Federal Emergency Management Agency (“FEMA”), which is part of the United States Department of Homeland Security (“DHS”). Therefore, CONTRACTOR must comply with all federal laws and regulations applicable to the receipt of FEMA grants, including, but not limited to, the contractual provision set forth in Title 2 of the Code of Federal Regulations, Part 200, in connection with the CONTRACTOR’s performance of the work or services covered by the Agreement (the “Project”). All such federal laws and regulations shall be deemed to be inserted in the Agreement and the Agreement shall be read and enforced as though such federal laws and regulations were included therein. Anything to the contrary herein notwithstanding, all FEMA-mandated terms shall be deemed to control in the event of a conflict with other provisions contained in the Agreement. The CONTRACTOR shall not perform any act, fail to perform any act, or refuse to comply with any AGENCY request that would cause the AGENCY to be in violation of these FEMA terms and conditions or any other federal law or regulation applicable to the receipt of FEMA grants. If any provision of the Agreement shall be such as to effect noncompliance with any FEMA requirement, such provision shall not be deemed to form a part thereof, but the balance of the Agreement shall remain in full force and effect. In addition, the CONTRACTOR agrees to the following specific provisions:

#### **1.01 Debarment**

1. The CONTRACTOR and any prospective lower tier participant certifies, by submission of this proposal, that neither it nor its principals is presently debarred, suspended, proposed for debarment, declared ineligible, or voluntarily excluded from participation in this transaction by any Federal department or agency.
2. The AGENCY will insure the CONTRACTOR and any lower participants are not debarred by checking the governments Excluded Parties List System at SAM.gov prior to executing the Contract and/or subsequent Job Orders.

#### **1.02 Cost Plus Percentage Not Allowed**

1. Notwithstanding any provisions in the Agreement to the contrary, the CONTRACTOR and any prospective lower tier participant are prohibited from using cost plus percentage contracts. This includes, but is not limited to the use of percentages for change orders or mark-ups on subcontractors or materials. Cost plus fixed fee either lump sum or unit price is authorized.

#### **1.03 Additional Federal Contracting Requirements**

1. The CONTRACTOR must comply with Executive Order 11246 of September 24, 1965, entitled Equal Employment Opportunity, as amended by Executive Order 11375 of

October 13, 1967, and as supplemented in Department of Labor regulations (41 CFR Chapter 60).

2. The CONTRACTOR must comply with the requirements of the Age Discrimination Act of 1975 (42 U.S.C. § 6101 *et seq.*), which prohibits discrimination on the basis of age in any program or activity receiving federal financial assistance.
3. The CONTRACTOR must comply with the requirements of Titles I, II, and III of the Americans with Disabilities Act, which prohibits recipients of federal funding from discriminating on the basis of disability in the operation of public entities, public and private transportation systems, places of public accommodation, and certain testing entities (42 U.S.C. §§ 12101–12213).
4. The CONTRACTOR must comply with the requirements of Title VI of the Civil Rights Act of 1964 (42 U.S.C. § 2000d *et seq.*), which provides that no person in the United States will, on the grounds of race, color, or national origin, be excluded from participation in, be denied the benefits of, or be subjected to discrimination under any program or activity receiving Federal financial assistance. Implementing regulations for the Act are found at 6 C.F.R. Part 21 and 44 C.F.R. Part 7.
5. The CONTRACTOR must comply with Title VIII of the Civil Rights Act of 1968, which prohibits CONTRACTORS from discriminating in the sale, rental, financing, and advertising of dwellings, or in the provision of services in connection therewith, on the basis of race, color, national origin, religion, disability, familial status, and sex (42 U.S.C. § 3601 *et seq.*), as implemented by the Department of Housing and Urban Development at 24 C.F.R. Part 100. The prohibition on disability discrimination includes the requirement that new multifamily housing with four or more dwelling units—i.e., the public and common use areas and individual apartment units (all units in buildings with elevators and ground-floor units in buildings without elevators)—be designed and constructed with certain accessible features (see 24 C.F.R. § 100.201).
6. The CONTRACTOR must comply with the Copeland Anti-Kickback Act (18 U.S.C. § 874) as supplemented in Department of Labor regulations (29 CFR Part 3).
7. The CONTRACTOR must comply with the Davis-Bacon Act (40 U.S.C. §§ 276a to 276a7) as supplemented by Department of Labor regulations (29 CFR Part 5).
  - a. This project is a public work in the State of California, funded in whole or in part with public funds. Therefore, the higher of the two applicable prevailing wage rates, federal or state, will be enforced.
8. The CONTRACTOR must comply with Sections 103 and 107 of the Contract Work Hours and Safety Standards Act (40 U.S.C. § 327330) as supplemented by Department of Labor regulations (29 CFR Part 5).
9. The CONTRACTOR must provide reporting as specified in the plans, specifications and deliverables section of the Agreement.

10. The AGENCY shall have patent rights with respect to any discovery or invention which arises or is developed in the course of or under such Agreement.
11. The AGENCY shall have copyrights and rights respective to any data which arises or is developed in the course of or under such Agreement.
12. The AGENCY, State, the Federal grantor agency, the Comptroller General of the United States, or any of their duly authorized representatives shall have access to any books, documents, papers, and records of the CONTRACTOR which are directly pertinent to that specific contract for the purpose of making audit, examination, excerpts, and transcriptions.
13. The CONTRACTOR must maintain records for three years after grantees or subgrantees make final payments and all other pending matters are closed.
14. The CONTRACTOR must comply with all applicable standards, orders, or requirements issued under section 306 of the Clean Air Act (42 U.S.C. § 1857(h)), section 508 of the Clean Water Act (33 U.S.C. § 1368), Executive Order 11738, and Environmental Protection Agency regulations (40 CFR part 15). (Contracts, subcontracts, and subgrants of amounts in excess of \$100,000).
15. The CONTRACTOR must comply with section 6002 of the Solid Waste Disposal Act, as amended by the Resource Conservation and Recovery Act. The requirements of Section 6002 include procuring only items designated in guidelines of the Environmental Protection Agency (EPA) at 40 C.F.R. Part 247 that contain the highest percentage of recovered materials practicable, consistent with maintaining a satisfactory level of competition, where the purchase price of the item exceeds \$10,000 or the value of the quantity acquired by the preceding fiscal year exceeded \$10,000; procuring solid waste management services in a manner that maximizes energy and resource recovery; and establishing an affirmative procurement program for procurement of recovered materials identified in the EPA guidelines.
16. The CONTRACTOR must comply with mandatory standards and policies relating to energy efficiency which are contained in the state energy conservation plan issued in compliance with the Energy Policy and Conservation Act (Pub. L. 94163, 89 Stat. 871).
17. The AGENCY is entitled to exercise all administrative, contractual, or other legal remedies permitted by law to enforce the CONTRACTOR's compliance with the terms of the Agreement.
18. The CONTRACTOR must acknowledge its use of federal funding when issuing requests for proposals, bid invitations, and other documents describing the Project in connection with performing the Agreement.
19. If the CONTRACTOR collects PII (Personally Identifiable Information) in connection with the

Project, the CONTRACTOR is required to have a publicly available privacy policy that describes what PII they collect, how they use the PII, whether they share PII with third parties, and how individuals may have their PII corrected where appropriate.

20. The CONTRACTOR must comply with the Drug-Free Workplace Act of 1988 (41 U.S.C. § 701 *et seq.*), which is adopted at 2 C.F.R Part 3001, which requires that all organizations receiving grants from any Federal agency agree to maintain a drug-free workplace.
21. The CONTRACTOR must comply with the requirements of 31 U.S.C. § 3729 which sets forth that no recipient of federal payments shall submit a false claim for payment. See also 38 U.S.C. § 38013812 which details the administrative remedies for false claims and statements made.
22. The CONTRACTOR must comply with Preference for U.S. Flag Air Carriers: (air carriers holding certificates under 49 U.S.C. § 41102) for international air transportation of people and property to the extent that such service is available, in accordance with the International Air Transportation Fair Competitive Practices Act of 1974 (49 U.S.C. § 40118) and the interpretative guidelines issued by the Comptroller General of the United States in the March 31, 1981, amendment to Comptroller General Decision B-138942.
23. The CONTRACTOR must comply with the Title VI of the Civil Rights Act of 1964 (Title VI) prohibition against discrimination on the basis of national origin, which requires that recipients of federal financial assistance take reasonable steps to provide meaningful access to persons with limited English proficiency (“LEP”) to their programs and services. Providing meaningful access for persons with LEP may entail providing language assistance services, including oral interpretation and written translation.
24. The CONTRACTOR must comply with 31 U.S.C. § 1352, which provides that none of the funds provided under an award may be expended by the CONTRACTOR to pay any person to influence, or attempt to influence an officer or employee of any agency, a Member of Congress, an officer or employee of Congress, or an employee of a Member of Congress in connection with any Federal action concerning the award or renewal.
25. Unless otherwise provided by law, the CONTRACTOR is subject to the Bayh-Dole Act, Pub. L. No. 96-517, as amended, and codified in 35 U.S.C. § 200 *et seq.* The CONTRACTOR is subject to the specific requirements governing the development, reporting, and disposition of rights to inventions and patents resulting from financial assistance awards in 37 C.F.R. Part 401 and the standard patent rights clause in 37 C.F.R. § 401.14.
26. The CONTRACTOR must comply with U.S. Executive Order 13224 and U.S. law that prohibit transactions with, and the provisions of resources and support to, individuals and organizations associated with terrorism.

27. The CONTRACTOR must comply with the requirements of the government-wide award term which implements Section 106(g) of the Trafficking Victims Protection Act (TVPA) of 2000, as amended (22 U.S.C. § 7104). This is implemented in accordance with OMB Interim Final Guidance, Federal Register, Volume 72, No. 218, November 13, 2007. Full text of the award term is located at 2 CFR § 175.15.
28. The CONTRACTOR must comply with the Rehabilitation Act of 1973, including all sections, that prohibits discrimination on the basis of disability. The standards for deciding if employment discrimination exists under the Rehabilitation Act are the same as those used in Title I of the Americans with Disabilities Act.
29. The CONTRACTOR must maintain the currency of the information in the Universal Identifier and System of Award Management (SAM) until submission of the final financial report required under the award or until the CONTRACTOR receives final payment, whichever is later, as required by 2 C.F.R. Part 25.
30. The CONTRACTOR must comply with requirements of the Uniting and Strengthening America by Providing Appropriate Tools Required to Intercept and Obstruct Terrorism Act (USA PATRIOT Act), which amends 18 U.S.C. §§ 175–175c. Among other things, the USA PATRIOT Act prescribes criminal penalties for possession of any biological agent, toxin, or delivery system of a type or in a quantity that is not reasonably justified by a prophylactic, protective, bona fide research, or other peaceful purpose.
31. The CONTRACTOR must comply with the statutory requirements for whistleblower protections (if applicable) at 10 U.S.C § 2409, 41 U.S.C. § 4712, and 10 U.S.C. § 2324, 41 U.S.C. §§ 4304 and 4310.
32. The CONTRACTOR must obtain DHS’s approval prior to using the DHS seal(s), logos, crests or reproductions of flags or likenesses of DHS agency officials, including use of the United States Coast Guard seal, logo, crests or reproductions of flags or likenesses of Coast Guard officials.
33. The CONTRACTOR must acknowledge and agree—and require any sub-CONTRACTORS, successors, transferees, and assignees to acknowledge and agree—to comply with applicable provisions governing DHS access to records, accounts, documents, information, facilities, and staff. Additionally:
  - a. The CONTRACTOR must cooperate with any compliance review or complaint investigation conducted by DHS;
  - b. The CONTRACTOR must give DHS access to and the right to examine and copy records, accounts, and other documents and sources of information related to the grant and permit access to facilities, personnel, and other individuals and information as may be necessary, as required by DHS regulations and other applicable laws or program guidance;

- c. The CONTRACTOR must submit timely, complete, and accurate reports to the appropriate DHS officials and maintain appropriate backup documentation to support the reports;
- d. The CONTRACTOR must comply with all other special reporting, data collection, and evaluation requirements, as prescribed by law or detailed in program guidance;
- e. If, during the past three years, the CONTRACTOR has been accused of discrimination on the grounds of race, color, national origin (including limited English proficiency), sex, age, disability, religion, or familial status, the CONTRACTOR must provide a list of all such proceedings, pending or completed, including outcome and copies of settlement agreements to the DHS awarding office (FEMA) and the DHS Office of Civil Rights and Civil Liberties; and
- f. In the event any court or administrative agency makes a finding of discrimination on grounds of race, color, national origin (including limited English proficiency), sex, age, disability, religion, or familial status against the CONTRACTOR, or the CONTRACTOR settles a case or matter alleging such discrimination, the CONTRACTOR must forward a copy of the complaint and findings to the DHS Component and/or awarding office (FEMA).

The United States has the right to seek judicial enforcement of these obligations.

**AMENDMENT No. 1**  
**to**  
**Agreement for Professional Services**  
**between**  
**Monterey County Water Resources Agency and GEI Consultants, Inc.**

The undersigned parties hereby agree to amend that certain Agreement for Professional Services between the Monterey County Water Resources Agency (hereinafter "Agency") and GEI Consultants, Inc., (hereinafter "CONTRACTOR") executed and effective on February 13, 2023 (hereinafter "Agreement").

Section 3 of the Agreement is hereby amended to read as follows:

- 3. Payments to CONTRACTOR; maximum liability. Subject to the limitations set forth herein, Agency shall pay to CONTRACTOR in accordance with the fee schedules set forth in Exhibit B. The maximum amount payable to CONTRACTOR under this contract is **three hundred seventy thousand dollars (\$370,000)**, summarized below:

\$200,000 Original Agreement  
\$170,000 Amendment No. 1  
\$370,000 Maximum Amount Payable

All other provisions of the Agreement remain in full force and effect.

IN WITNESS WHEREOF, Agency and CONTRACTOR have caused this Amendment No. 1 to be executed as follows:

**MONTEREY COUNTY**  
**WATER RESOURCES AGENCY:**

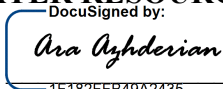
By:   
1F182FFB49A2435...  
Ara Azhderian  
General Manager

Date: 5/26/2023 | 8:52 AM PDT

**CONTRACTOR:**

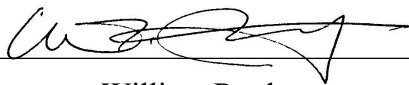
By:   
Type Name: William Rettberg  
Title: Senior Vice President

Date: 5/8/2023

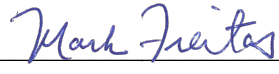
By:   
Type Name: Mark Freitas  
Title: Vice President

Date: 5/8/2023

\* INSTRUCTIONS: If CONTRACTOR is a corporation (including limited liability and nonprofit corporations), the full legal name of the corporation shall be set forth together with the signatures of two specified officers. If CONTRACTOR is a partnership, the name of the partnership shall be set forth together with the signature of a partner with authority to execute this Agreement on behalf of the partnership. If CONTRACTOR is contracting in an individual capacity, the individual shall set forth the name of his or her business, if any, and shall personally sign the Agreement.

**MCWRA – GEI Consultants, Inc.**  
**Amendment No. 1**

\*\*\*\*\*

Approved as to form <sup>1</sup>:

Approved as to fiscal provisions:

DocuSigned by:  
*Kelly L. Doulon*  
22D690CA05A940E...  
Assistant County Counsel

DocuSigned by:  
*Juan Pablo Lopez*  
A59152F49ADC476...  
Administrative Analyst

Dated: 5/25/2023 | 11:43 AM PDT

Dated: 5/26/2023 | 8:05 AM PDT

\_\_\_\_\_  
County Counsel – Risk Manager:

DocuSigned by:  
*Patricia Ruiz*  
E79EF64E57454F6...  
Auditor-Controller <sup>2</sup>:

Dated: \_\_\_\_\_

Dated: 5/25/2023 | 1:52 PM PDT

<sup>1</sup>Approval by County Counsel is required, and/or when legal services are rendered

<sup>2</sup>Approval by Auditor-Controller is required



***Before the Board of Directors of the Monterey County Water Resources Agency  
County of Monterey, State of California***

BOARD ORDER No. \_\_\_\_\_

**APPROVE AMENDMENT NO. 2 OF THE AGREEMENT FOR )  
PROFESSIONAL SERVICES WITH GEI CONSULTANTS, INC, IN )  
THE AMOUNT OF \$70,000 FOR ENGINEERING DESIGN & )  
PROJECT MANAGEMENT SERVICES FOR STORM DAMAGE )  
REPAIR DESIGN AND IMPLEMENTATION OF THE NACIMIENTO )  
DAM HYDRO-PLANT’S SOUTH ACCESS ROAD; AND AUTHORIZE )  
THE GENERAL MANAGER TO EXECUTE THE AMENDMENT. )**

Upon motion of Director \_\_\_\_\_, seconded by Director \_\_\_\_\_, and carried by those members present, the Board of Directors hereby:

1. Approve Amendment No. 2 of the Agreement for Professional Services with GEI Consultants, Inc, in the amount of \$70,000 for engineering design & project management services for storm damage repair design and implementation of the Nacimiento Dam Hydro-plant’s South Access Road; and
2. Authorizes the General Manager to execute the amendment.

PASSED AND ADOPTED on this **18th** day of **March 2024**, by the following vote, to-wit:

\_\_\_\_\_  
BY: Mike LeBarre, Chair  
Board of Directors

\_\_\_\_\_  
ATTEST: Ara Azhderian  
General Manager



***Before the Board of Directors of the Monterey County Water Resources Agency  
County of Monterey, State of California***

BOARD ORDER No. 24-005

**APPROVE AMENDMENT NO. 2 OF THE AGREEMENT FOR )  
PROFESSIONAL SERVICES WITH GEI CONSULTANTS, INC, IN )  
THE AMOUNT OF \$70,000 FOR ENGINEERING DESIGN & )  
PROJECT MANAGEMENT SERVICES FOR STORM DAMAGE )  
REPAIR DESIGN AND IMPLEMENTATION OF THE NACIMIENTO )  
DAM HYDRO-PLANT’S SOUTH ACCESS ROAD; AND AUTHORIZE )  
THE GENERAL MANAGER TO EXECUTE THE AMENDMENT. )**

Upon motion of Director John Baillie, seconded by Director Mark Gonzalez, and carried by those members present, the Board of Directors hereby:

1. Approve Amendment No. 2 of the Agreement for Professional Services with GEI Consultants, Inc, in the amount of \$70,000 for engineering design & project management services for storm damage repair design and implementation of the Nacimiento Dam Hydro-plant’s South Access Road; and
2. Authorizes the General Manager to execute the amendment.

PASSED AND ADOPTED on this **18th** day of **March 2024**, by the following vote, to-wit:

AYES: Mike LeBarre, Matt Simis, Mark Gonzalez, Deidre Sullivan, Mike Scattini, John Baillie, Marvin Borzini

NOES: None

ABSENT: Ken Ekelund, Jason Smith

DocuSigned by:  
*Mike LeBarre*  
3DE98F68D10F4DB...

BY: Mike LeBarre, Chair  
Board of Directors

DocuSigned by:  
*Ara Azhderian*  
1E182FFB49A243E...

ATTEST: Ara Azhderian  
General Manager



# County of Monterey

## Item No.6

### Board Report

Board of Supervisors  
Chambers  
168 W. Alisal St., 1st Floor  
Salinas, CA 93901

Legistar File Number: WRAG 24-045

March 18, 2024

**Introduced:** 3/13/2024

**Current Status:** Agenda Ready

**Version:** 1

**Matter Type:** WR General Agenda

Approve an Agreement for Services with Industrial Machine Shop for a new contract for \$250,000 for: electrical motor repair and rebuilding, well pump and equipment inspection, rebuilding, machining, as well as fabrication services for the Recycle Water Project Facilities; and authorize the General Manager to execute the agreement. (Staff: Peter Vannerus)

#### RECOMMENDATION:

It is recommended that the Monterey County Water Resources Agency Board of Directors:

Approve an Agreement for Services with Industrial Machine Shop with a contract term to June 30, 2027, and an amount not to exceed \$250,000 for electrical motor repair and rebuilding, well pump and equipment inspection, rebuilding, machining, as well as fabrication services for the Recycle Water Project Facilities; and authorize the General Manager to execute the agreement.

#### SUMMARY/DISCUSSION:

With aging equipment in the Recycle Water Projects, primarily in the Castroville Seawater Intrusion Project and the Salinas River Diversion Facility, repairs are necessary to keep the equipment and facilities in satisfactory operational condition. The primary components for repair and maintenance include the CSIP Supplemental Well pumping equipment and the SRDF pumping equipment. A local contractor certified and experienced in electrical motor repairs and rebuilding along with pumps and support equipment is critical for timely and quality repairs. The scope of work under this Agreement includes electrical motor repair and rebuilding, well pump and equipment inspection, rebuilding, machining, as well as fabrication services for the CSIP and SRDF. These projects are tied to maintenance plans for the supplemental wells and routine maintenance with the SRDF to keep the facilities operating and to ensure they are in good working condition. Funds for the agreement will be tied to budgeted items in Fund 131 and Fund 134 over the contract term.

Immediate needs for contract are to inspect and rebuild the second pair of SRDF pumps and motors, to expedite the completion for on time facility start in the spring 2024. The first pair of SRDF pumps were completed last year. CSIP well motor rebuilding and balancing are also needing for the Well Maintenance Plan project currently underway.

#### OTHER AGENCY INVOLVEMENT:

Recommended for Approval by Finance Committee on March 1st, 2024

#### FINANCING:

Funds for this agreement will be appropriated from Funds 131-Castroville Seawater Intrusion Project

and 134- Salinas River Diversion Facility.

Prepared by: Pete Vannerus, Associate Water Resources Engineer, (831) 755-4860

Approved by: Ara Azhderian, General Manager, (831) 755-4860

Attachments:

1. Agreement for Services with Industrial Machine Shop for Recycle Water Projects
2. Board Order



# County of Monterey

**Item No.6**

Board of Supervisors  
Chambers  
168 W. Alisal St., 1st Floor  
Salinas, CA 93901

## Board Report

**Legistar File Number: WRAG 24-045**

**March 18, 2024**

**Introduced:** 3/13/2024

**Current Status:** Agenda Ready

**Version:** 1

**Matter Type:** WR General Agenda

Approve an Agreement for Services with Industrial Machine Shop for a new contract for \$250,000 for: electrical motor repair and rebuilding, well pump and equipment inspection, rebuilding, machining, as well as fabrication services for the Recycle Water Project Facilities; and authorize the General Manager to execute the agreement.

### RECOMMENDATION:

It is recommended that the Monterey County Water Resources Agency Board of Directors:

Approve an Agreement for Services with Industrial Machine Shop with a contract term to June 30, 2027, and an amount not to exceed \$250,000 for electrical motor repair and rebuilding, well pump and equipment inspection, rebuilding, machining, as well as fabrication services for the Recycle Water Project Facilities; and authorize the General Manager to execute the agreement.

### SUMMARY/DISCUSSION:

With aging equipment in the Recycle Water Projects, primarily in the Castroville Seawater Intrusion Project and the Salinas River Diversion Facility, repairs are necessary to keep the equipment and facilities in satisfactory operational condition. The primary components for repair and maintenance include the CSIP Supplemental Well pumping equipment and the SRDF pumping equipment. A local contractor certified and experienced in electrical motor repairs and rebuilding along with pumps and support equipment is critical for timely and quality repairs. The scope of work under this Agreement includes electrical motor repair and rebuilding, well pump and equipment inspection, rebuilding, machining, as well as fabrication services for the CSIP and SRDF. These projects are tied to maintenance plans for the supplemental wells and routine maintenance with the SRDF to keep the facilities operating and to ensure they are in good working condition. Funds for the agreement will be tied to budgeted items in Fund 131 and Fund 134 over the contract term.

Immediate needs for contract are to inspect and rebuild the second pair of SRDF pumps and motors, to expedite the completion for on time facility start in the spring 2024. The first pair of SRDF pumps were completed last year. CSIP well motor rebuilding and balancing are also needing for the Well Maintenance Plan project currently underway.

### OTHER AGENCY INVOLVEMENT:

Recommended for Approval by Finance Committee on March 1st, 2024

### FINANCING:

Funds for this agreement will be appropriated from Funds 131-Castroville Seawater Intrusion Project and 134- Salinas River Diversion Facility.

Prepared by: Pete Vannerus, Associate Water Resources Engineer, (831) 755-4860

Approved by: Ara Azhderian, General Manager, (831) 755-4860

Attachments:

1. Agreement for Services with Industrial Machine Shop for Recycle Water Projects
2. Board Order

**MONTEREY COUNTY WATER RESOURCES AGENCY**  
**AND** Industrial Machine Shop, Inc.  
**AGREEMENT FOR SERVICES**

This is an agreement ("Agreement") between the Monterey County Water Resources Agency, hereinafter called "Agency," and Industrial Machine Shop, a Corporation hereinafter called "CONTRACTOR".

In consideration of the mutual covenants and conditions set forth in this Agreement, the parties agree as follows:

1. Employment of CONTRACTOR. Agency hereby engages CONTRACTOR and CONTRACTOR hereby agrees to perform the services set forth in Exhibit A, in conformity with the terms of this Agreement. CONTRACTOR will complete all work in accordance with the **Scope of Work/Work Schedule set forth in Exhibit A:**
  - (a) The scope of work is briefly described and outlined as follows:

Electrical motor repair and rebuilding, well pump and equipment inspection, rebuilding, machining, and fabrication services for the Recycle Water Projects.
  - (b) The CONTRACTOR shall perform its services under this agreement in accordance with usual and customary care and with generally accepted practices in effect at the time the services are rendered. The CONTRACTOR and its agents and employees performing work hereunder are specially trained, experienced, competent, and appropriately licensed to perform the work and deliver the services required by this Agreement.
  - (c) CONTRACTOR, its agents and employees shall perform all work in a safe and skillful manner and in compliance with all applicable laws and regulations. All work performed under this Agreement that is required by law to be performed or supervised by licensed personnel shall be performed in accordance with such licensing requirements.
  - (d) CONTRACTOR shall furnish, at its own expense, all materials and equipment necessary to carry out the terms of this Agreement, except as otherwise provided herein. CONTRACTOR shall not use Agency premises, property (including equipment, instruments, or supplies) or personnel for any purpose other than in the performance of its obligations hereunder.
2. Term of Agreement. The term of this Agreement shall begin on March 18th, 2024 by CONTRACTOR and Agency, and will terminate on June 30th, 2027, unless earlier terminated as provided herein.
3. Payments to CONTRACTOR; maximum liability. Subject to the limitations set forth herein,

Agency shall pay CONTRACTOR in accordance with the fee schedule set forth in Exhibit B. The maximum amount payable to CONTRACTOR under this contract is Two Hundred and Fifty Thousand Dollars,

(\$ 250,000).

4. Monthly Invoices by CONTRACTOR; Payment.

- (a) CONTRACTOR shall submit to Agency an invoice, in a format approved by Agency, setting forth the amounts claimed by CONTRACTOR, together with an itemized basis for such amounts, and setting forth such other pertinent information Agency may require. CONTRACTOR shall submit such invoice monthly or as agreed by Agency, but in no event shall such invoice be submitted later than 30 days after completion of CONTRACTOR's work hereunder. Agency shall certify the claim if it complies with this contract and shall promptly submit such claim to the Monterey County Auditor-Controller, who shall pay the certified amount within 30 days after receiving the invoice certified by Agency. It is understood and agreed that CONTRACTOR shall complete all work described in Exhibit A for an amount not exceeding that set forth above, notwithstanding CONTRACTOR's submission of periodic invoices.
- (b) CONTRACTOR shall submit to Agency an invoice via email to [WRAAccountsPayable@co.monterey.ca.us](mailto:WRAAccountsPayable@co.monterey.ca.us) and to the Contract Administrator listed in Section 26.
- (c) CONTRACTOR agrees that Agency may withhold five percent (5%) of the amount requested by CONTRACTOR from any progress payment, until such time as all goods and services are received in a manner and form acceptable to Agency.
- (d) If, as of the date of execution of this Agreement, CONTRACTOR has already received payment from Agency for work which is the subject of this Agreement, such amounts shall be deemed to have been paid under this Agreement and shall be counted toward Agency's maximum liability set forth above.
- (e) CONTRACTOR shall not be reimbursed for travel expenses unless expressly approved in writing in accordance with this Agreement.

5. Indemnification. CONTRACTOR shall indemnify, defend, and hold harmless the Agency and the County of Monterey, their officers, agents, and employees, from and against any and all claims, liabilities, and losses whatsoever (including damages to property and injuries to or death of persons, court costs, and reasonable attorneys' fees) occurring or resulting to any and all persons, firms or corporations furnishing or supplying work, services, materials, or supplies in connection with the performance of this Agreement, and from any and all claims, liabilities, and losses occurring or resulting to any person, firm, or corporation for damage, injury, or death arising out of or connected with the CONTRACTOR's performance of this Agreement, unless such claims, liabilities, or losses arise out of the sole negligence, active negligence, or willful misconduct of the Agency. "CONTRACTOR's performance" includes CONTRACTOR's

action or inaction and the action or inaction of CONTRACTOR's officers, employees, agents and subCONTRACTORS.

6. Insurance.

6.1 Evidence of Coverage:

Prior to commencement of this Agreement, the CONTRACTOR shall provide a "Certificate of Insurance" certifying that coverage as required herein has been obtained. Individual endorsements executed by the insurance carrier shall accompany the certificate. In addition the CONTRACTOR upon request shall provide a certified copy of the policy or policies.

This verification of coverage shall be sent to the Agency's Contact, unless otherwise directed. The CONTRACTOR shall not receive a "Notice to Proceed" with the work under this Agreement until it has obtained all insurance required and such, insurance has been approved by the Agency. This approval of insurance shall neither relieve nor decrease the liability of the CONTRACTOR.

6.2 Qualifying Insurers:

All coverage's, except surety, shall be issued by companies which hold a current policy holder's alphabetic and financial size category rating of not less than A-VII, according to the current Best's Key Rating Guide or a company of equal financial stability that is approved by the County's Purchasing Manager.

6.3 Insurance Coverage Requirements:

Without limiting CONTRACTOR's duty to indemnify, CONTRACTOR shall maintain in effect throughout the term of this Agreement a policy or policies of insurance with the following minimum limits of liability:

Commercial general liability insurance, including but not limited to premises and operations, including coverage for Bodily Injury and Property Damage, Personal Injury, Contractual Liability, Broad form Property Damage, Independent CONTRACTORS, Products and Completed Operations, with a combined single limit for Bodily Injury and Property Damage of not less than \$1,000,000 per occurrence.

Exemption/Modification (Justification attached; subject to approval).

Business automobile liability insurance, covering all motor vehicles, including owned, leased, non-owned, and hired vehicles, used in providing services under this Agreement, with a combined single limit for Bodily Injury and Property Damage of not less than \$1,000,000 per occurrence.

Exemption/Modification (Justification attached; subject to approval).

Workers' Compensation Insurance, if CONTRACTOR employs others in the performance of this Agreement, in accordance with California Labor Code section

3700 and with Employer's Liability limits not less than \$1,000,000 each person, \$1,000,000 each accident and \$1,000,000 each disease.

Exemption/Modification (Justification attached; subject to approval).

Professional liability insurance, if required for the professional services being provided, (e.g., those persons authorized by a license to engage in a business or profession regulated by the California Business and Professions Code), in the amount of not less than \$1,000,000 per claim and \$2,000,000 in the aggregate, to cover liability for malpractice or errors or omissions made in the course of rendering professional services. If professional liability insurance is written on a "claims-made" basis rather than an occurrence basis, the CONTRACTOR shall, upon the expiration or earlier termination of this Agreement, obtain extended reporting coverage ("tail coverage") with the same liability limits. Any such tail coverage shall continue for at least three years following the expiration or earlier termination of this Agreement.

Exemption/Modification (Justification attached; subject to approval).

#### 6.4 Other Insurance Requirements.

All insurance required by this Agreement shall be with a company acceptable to the Agency and issued and executed by an admitted insurer authorized to transact Insurance business in the State of California. Unless otherwise specified by this Agreement, all such insurance shall be written on an occurrence basis, or, if the policy is not written on an occurrence basis, such policy with the coverage required herein shall continue in effect for a period of three years following the date CONTRACTOR completes its performance of services under this Agreement.

Each liability policy shall provide that the Agency shall be given notice in writing at least thirty days in advance of any endorsed reduction in coverage or limit, cancellation, or intended non-renewal thereof. Each policy shall provide coverage for CONTRACTOR and additional insureds with respect to claims arising from each subCONTRACTOR, if any, performing work under this Agreement, or be accompanied by a certificate of insurance from each subCONTRACTOR showing each subCONTRACTOR has identical insurance coverage to the above requirements.

Commercial general liability and automobile liability policies shall provide an endorsement naming the Monterey County Water Resources Agency and the County of Monterey, their officers, agents, and employees as Additional Insureds with respect to liability arising out of the CONTRACTOR'S work, including ongoing and completed operations, and shall further provide that such insurance is primary insurance to any insurance or self-insurance maintained by the County and that the insurance of the Additional Insureds shall not be called upon to contribute to a loss covered by the CONTRACTOR'S insurance. The required endorsement form for Commercial General Liability Additional Insured is ISO Form CG 20 10 11-85 or CG 20 10 10 01 in tandem with CG 20 37 10 01 (2000). The required

endorsement form for Automobile Additional Insured endorsement is ISO Form CA 20 48 02 99.

Prior to the execution of this Agreement by the Agency, CONTRACTOR shall file certificates of insurance with the Agency's contract administrator, showing that the CONTRACTOR has in effect the insurance required by this Agreement. The CONTRACTOR shall file a new or amended certificate of insurance within five calendar days after any change is made in any insurance policy, which would alter the information on the certificate then on file. Acceptance or approval of insurance shall in no way modify or change the indemnification clause in this Agreement, which shall continue in full force and effect.

CONTRACTOR shall at all times during the term of this Agreement maintain in force the insurance coverage required under this Agreement and shall send, without demand by Agency, annual certificates to Agency's Contract Administrator. If the certificate is not received by the expiration date, Agency shall notify CONTRACTOR and CONTRACTOR shall have five calendar days to send in the certificate, evidencing no lapse in coverage during the interim. Failure by CONTRACTOR to maintain such insurance is a default of this Agreement, which entitles Agency, at its sole discretion, to terminate this Agreement immediately.

7. Maintenance of Records. CONTRACTOR shall prepare, maintain and preserve all reports and records that may be required by federal, State, and local rules and regulations relating to services performed under this Agreement. CONTRACTOR shall retain all such records for at least five years from the date of final payment, or until any litigation relating to this Agreement is concluded, whichever is later.
8. Right to Audit at Any Time. Agency officials shall have the right, at any time during regular working hours and on reasonable advance notice, to examine, monitor and audit all work performed and all records, documents, conditions, activities and procedures of CONTRACTOR or its subCONTRACTORS relating to this Agreement. Government Code Section 8546.7 provides that an audit by the State Auditor General may be performed up to three years after the final payment under any contract involving the expenditure of public funds in excess of \$10,000.
9. Confidentiality; Return of Records. CONTRACTOR and its officers, employees, agents, and subCONTRACTORS shall comply with all federal, State and local laws providing for the confidentiality of records and other information. To the extent permitted by applicable law and regulations, CONTRACTOR shall maintain confidentiality with respect to Agency's well database and other water use data.

CONTRACTOR shall not disclose any confidential information received from Agency or prepared in connection with the performance of this Agreement without the express permission of Agency. CONTRACTOR shall promptly transmit to Agency all requests for disclosure of any such confidential information. CONTRACTOR shall not use any confidential information gained through the performance of this Agreement except for the

purpose of carrying out CONTRACTOR's obligations hereunder. When this Agreement expires or terminates, CONTRACTOR shall return to Agency all records, which CONTRACTOR utilized or received, from Agency to perform services under this Agreement.

10. Termination. Either party may terminate this Agreement by giving written notice of termination to the other party at least thirty (30) days prior to the effective date of termination, which date shall be specified in any such notice. In the event of such termination, the amount payable hereunder shall be reduced in proportion to the services provided prior to the effective date of termination. Agency may terminate this Agreement at any time for good cause effective immediately upon written notice to CONTRACTOR. "Good cause" includes, without limitation, the failure of CONTRACTOR to perform the required services at the time and in the manner provided herein. If Agency terminates this Agreement for good cause, Agency may be relieved of the payment of any consideration to CONTRACTOR, and Agency may proceed with the work in any manner, which it deems proper. Costs incurred by Agency thereby shall be deducted from any sum due CONTRACTOR.
11. Amendments and Modifications. No modification or amendment of this agreement shall be valid unless it is set forth in writing and executed by the parties.
12. Non-Discrimination. Throughout the performance of this Agreement, CONTRACTOR will not unlawfully discriminate against any person because of race, color, religion, gender, national origin, ancestry, physical disability, medical condition, marital status, age older than 40, or sexual orientation, gender identity or any other status protected under federal, state or local law, either in CONTRACTOR's employment practices or in the furnishing of services to recipients. CONTRACTOR shall ensure that the evaluation and treatment of its employees and applicants for employment and all persons receiving and requesting services are free of such discrimination. CONTRACTOR shall comply fully with all federal, State and local laws and regulations which prohibit discrimination. The provision of services primarily or exclusively to any target population designated herein shall not be deemed prohibited discrimination.
13. Independent Contractor. In its performance under this Agreement, CONTRACTOR is at all times acting and performing as an independent CONTRACTOR and not an employee of Agency. No offer or obligation of employment with Agency is intended in any manner, and CONTRACTOR shall not become entitled by virtue of this Agreement to receive from Agency any form of benefits accorded to employees including without limitation leave time, health insurance, workers compensation coverage, disability benefits, and retirement contributions. CONTRACTOR shall be solely liable for and obligated to pay directly all applicable taxes, including without limitation federal and State income taxes and social security arising out of CONTRACTOR's performance of this Agreement. In connection therewith, CONTRACTOR shall defend, indemnify, and hold harmless Agency from any and all liability, which Agency may incur because of CONTRACTOR's failure to make such payments.

14. Delegation of Duties; Subcontracting. CONTRACTOR is engaged by Agency for its unique qualifications and abilities. CONTRACTOR may not, therefore, delegate any of its basic duties under this Agreement, except to the extent that delegation to CONTRACTOR's employees is contemplated herein. No work shall be subcontracted without the written consent of Agency, except as provided in this Agreement or its attachments. Notwithstanding any subcontract, CONTRACTOR shall continue to be liable to Agency for the performance of all work hereunder. CONTRACTOR shall not assign, sell, mortgage or otherwise transfer its interest or obligations in this Agreement without Agency's prior written consent.
15. Agency's Rights in Work Product. All original materials prepared by CONTRACTOR in connection with its work hereunder -- including but not limited to computer codes, customized computer routines developed using proprietary or commercial software packages, reports, documents, maps, graphs, charts, photographs and photographic negatives -- shall be the property of Agency and shall be delivered to Agency prior to final payment. CONTRACTOR may utilize any existing materials developed by CONTRACTOR prior to commencement of work under this Agreement, which materials shall remain the property of CONTRACTOR.
16. Compliance with Terms of Federal or State Grant. If any part of this Agreement has been or will be funded pursuant to a grant from the federal or State government in which Agency is the grantee, CONTRACTOR shall comply with all provisions of such grant applicable to CONTRACTOR's work hereunder, and said provisions shall be deemed a part of this Agreement as though fully set forth herein.
17. Conflict of Interest. CONTRACTOR warrants that it presently has no interest and shall not acquire any interest during the term of this Agreement, which would directly or indirectly conflict in any manner or to any degree with its full and complete performance of all services under this Agreement.
18. Governing Laws. This Agreement is entered into in the County of Monterey, State of California, and shall be construed and enforced in accordance with the laws of the State of California. The parties hereby agree that the County of Monterey shall be the proper venue for any dispute arising hereunder.
19. Compliance with Applicable Law. The parties shall comply with all applicable federal, state, and local laws and regulations in performing this Agreement.
20. Construction of Agreement. The parties agree that each party has fully participated in the review and revision of this Agreement and that any rule of construction to the effect that ambiguities are to be resolved against the drafting party shall not apply in the interpretation of this Agreement or any exhibit or amendment. To that end, it is understood and agreed that this Agreement has been arrived at through negotiation, and that neither party is to be deemed the party which prepared this Agreement within the meaning of Civil Code Section 1654. Section and paragraph headings appearing herein are for convenience only and shall not be used to interpret the terms of this Agreement.

21. Waiver. Any waiver of any term or condition hereof must be in writing. No such waiver shall be construed as a waiver of any other term or condition herein.
22. Successors and Assigns. This Agreement and all rights, privileges, duties and obligations hereunder, to the extent assignable or delegable, shall be binding upon and inure to the benefit of the parties and their respective successors, permitted assigns and heirs.
23. Contractor. The term “CONTRACTOR” as used in this Agreement includes CONTRACTOR’s officers, agents, and employees acting on Contactor’s behalf in the performance of this Agreement.
24. Interpretation of Conflicting Provisions. In the event of any conflict or inconsistency between the provisions of this Agreement and the Provisions of any exhibit or other attachment to this Agreement, the provisions of this Agreement shall prevail and control.
25. Time is of the Essence. The parties mutually acknowledge and agree that time is of the essence with respect to every provision hereof in which time is an element. No extension of time for performance of any obligation or act shall be deemed an extension of time for performance of any other obligation or act, nor shall any such extension create a precedent for any further or future extension.
26. Contract Administrators.

CONTRACTOR's designated principal responsible for administering  
 CONTRACTOR's work under this Agreement shall be  
Kyle Wilson

Agency's designated administrator of this Agreement shall be  
Pete Vannerus

27. Notices. Notices required under this Agreement shall be delivered personally or by electronic facsimile, or by first class or certified mail with postage prepaid. Notice shall be deemed effective upon personal delivery or facsimile transmission, or on the third day after deposit with the U.S. Postal Service. CONTRACTOR shall give Agency prompt notice of any change of address. Unless otherwise changed according to these notice provisions, notices shall be addressed as follows:

TO AGENCY	TO CONTRACTOR
Name: Pete Vannerus	Name: Kyle Wilson
Address: 1441 Schilling Pl., Salinas, CA	Address: 805 Vertin Ave, Salinas, CA 93901
Telephone: 831.755.4860	Telephone: 831-424-3471
Fax: 831.424.7935	Fax:
E-Mail: VannerusP@co.monterey.ca.us	E-Mail: Imssalinas@yahoo.com

28. Electronic Deliverables. Where feasible, all reports, documents and other printed information provided to the Agency pursuant to this Agreement shall be submitted in both written and Electronic formats in accordance with the specifications listed in Exhibit C.
29. Non-exclusive Agreement. This Agreement is non-exclusive and both parties reserve the right to contract with other entities for the same or similar services.
30. Execution of Agreement. Any individual executing this Agreement on behalf of an entity represents and warrants that he or she has the requisite authority to enter into this Agreement on behalf of such entity and to bind the entity to the terms and conditions hereof. This Agreement may be executed in two or more counterparts, each of which shall be deemed an original, but all of which together shall constitute one and the same agreement.
31. Exhibits. The following Exhibits are attached hereto and incorporated by reference:
  - Exhibit A - Scope of Work/ Work Schedule
  - Exhibit B - Payment Provisions
32. Entire Agreement --As of the effective date of this Agreement, this document, including all exhibits hereto, constitutes the entire agreement between the parties, and supersedes any and all prior written or oral negotiations and representations between the parties concerning all matters relating to the subject of this Agreement.

**MONTEREY COUNTY WATER RESOURCES AGENCY  
AND Industrial Machine Shop, Inc.**  
**AGREEMENT FOR SERVICES**

IN WITNESS WHEREOF, AGENCY and CONTRACTOR execute this agreement as follows:

**MONTEREY COUNTY WATER  
RESOURCES AGENCY:**

**CONTRACTOR:**

BY:

BY:

\_\_\_\_\_  
Ara Azhderian  
General Manager

\_\_\_\_\_  
Type Name: Skylar Wilson

Title: general manager

Date:

Date: 3/5/2024

BY:

\_\_\_\_\_  
Type Name: \_\_\_\_\_

Title: \_\_\_\_\_

Date: \_\_\_\_\_

\* INSTRUCTIONS: If CONTRACTOR is a corporation (including limited liability and nonprofit corporations), the full legal name of the corporation shall be set forth together with the signatures of two specified officers. If CONTRACTOR is a partnership, the name of the partnership shall be set forth together with the signature of a partner with authority to execute this Agreement on behalf of the partnership. If CONTRACTOR is contracting in an individual capacity, the individual shall set forth the name of his or her business, if any, and shall personally sign the Agreement.

( \_\_\_\_\_ )  
**Agreement/Amendment No #** ( \_\_\_\_\_ )

\*\*\*\*\*

Approved as to form <sup>1</sup>:

Approved as to fiscal provisions:

\_\_\_\_\_  
Assistant County Counsel

\_\_\_\_\_  
Administrative Analyst

Dated: \_\_\_\_\_

Dated: \_\_\_\_\_

\_\_\_\_\_  
County Counsel – Risk Manager:

\_\_\_\_\_  
Auditor-Controller <sup>2</sup>:

Dated: \_\_\_\_\_

Dated: \_\_\_\_\_

<sup>1</sup> Approval by County Counsel is required, and/or when legal services are rendered

<sup>2</sup> Approval by Auditor-Controller is required

EXHIBIT A  
SCOPE OF WORK

The scope of work shall include but is not limited to:

- Electrical motor repair and rebuilding
  - Well pump and equipment inspection, rebuilding, machining
  - Fabrication services
  - Any additional services IMS can provide
- All for the Recycle Water Project Facilities and Infrastructure
- Immediate needs are attached as a quoted item in Exhibit B

EXHIBIT B  
FEE SCHEDULE

Services for immediate needs are quoted below for the work at the Salinas River Diversion Facility. All other services and future needs shall be billed on a time and material basis at the rates:

- \$100 per hour for regular time during normal business hours
- \$150 per hour for overtime hours and weekend hours outside normal business hours
- Material no more than 10% markup

Industrial Machine Shop

805 Vertin Ave.  
 Salinas, CA 93901  
 Phone: (831)424-3471  
 E-Mail: imssalinas@yahoo.com

**Quote**

Date	Quote #
1/23/2024	3959

<b>Name / Address</b>
Monterey County Water Resources Agency

Rep	Project
	SRDF Pumps

Item	Description	Total
Repairs	Flowway vertical turbine pump Large 40' lift pump 2 stage 14" bowl unit Disassemble completely Pressure wash all parts Load up column pipe, head and couplers for powder coat - to be handled by customer (pick up and delivery) Rebuild 2 stage 14" bowls Trim impeller necks Bore and war ring bowls to match Replace all bushings Make up new 416 stainless steel bolts Repair bottom stainless steel strainer Make up 5 - 416 stainless steel line shafts Make up 1 shaft if needed Head nut and key Replace 6 couplers Replace spider sleeves Replace spider inserts Assemble unit  Materials: Spider sleeves Spider inserts 60' of 1 15/16" 416 stainless steel shaft Stainless steel bolts Packing 5 - 1 15/16" x 2 7/16" brass bushings 12" x 10" x 6" long brass bar  300 HP hollow shaft vertical motor Disassemble Clean and inspect Pressure wash	68,600.00
<b>Total</b>		

Industrial Machine Shop

805 Vertin Ave.  
 Salinas, CA 93901  
 Phone: (831)424-3471  
 E-Mail: imssalinas@yahoo.com

# Quote

Date	Quote #
1/23/2024	3959

<b>Name / Address</b>
Monterey County Water Resources Agency

Rep	Project
	SRDF Pumps

Item	Description	Total
	Bake, dip and rebake Balance rotor Replace all bearings Meg test Assemble and test run motor Material and labor included Sales Tax	0.00
<b>Total</b>		<b>\$68,600.00</b>



***Before the Board of Directors of the Monterey County Water Resources Agency  
County of Monterey, State of California***

BOARD ORDER No. \_

**Approve an Agreement for Services with Industrial Machine Shop with a contract term to June 30, 2027, and an amount not to exceed \$250,000 for electrical motor repair and rebuilding, well pump and equipment inspection, rebuilding, machining, as well as fabrication services for the Recycle Water Project Facilities; and authorize the General Manager to execute the agreement.**

Upon motion of Director, seconded by Director, and carried by those members present, the Board of Directors hereby:

Approve an Agreement for Services with Industrial Machine Shop with a contract term to June 30, 2027, and an amount not to exceed \$250,000 for electrical motor repair and rebuilding, well pump and equipment inspection, rebuilding, machining, as well as fabrication services for the Recycle Water Project Facilities; and authorize the General Manager to execute the agreement.

PASSED AND ADOPTED on this **18th** day of **March 2024**, by the following vote, to-wit:

AYES:

NOES:

ABSENT:

---

BY: Mike LeBarre, Chair  
Board of Directors

---

ATTEST: Ara Azhderian  
General Manager



***Before the Board of Directors of the Monterey County Water Resources Agency  
County of Monterey, State of California***

BOARD ORDER No. 24-006

**Approve an Agreement for Services with Industrial Machine Shop with a contract term to June 30, 2027, and an amount not to exceed \$250,000 for electrical motor repair and rebuilding, well pump and equipment inspection, rebuilding, machining, as well as fabrication services for the Recycle Water Project Facilities; and authorize the General Manager to execute the agreement.**

Upon motion of Director John Baillie, seconded by Director Mark Gonzalez, and carried by those members present, the Board of Directors hereby:

Approve an Agreement for Services with Industrial Machine Shop with a contract term to June 30, 2027, and an amount not to exceed \$250,000 for electrical motor repair and rebuilding, well pump and equipment inspection, rebuilding, machining, as well as fabrication services for the Recycle Water Project Facilities; and authorize the General Manager to execute the agreement.

PASSED AND ADOPTED on this **18th** day of **March 2024**, by the following vote, to-wit:

AYES: Mike LeBarre, Matt Simis, Mark Gonzalez, Deidre Sullivan, Mike Scattini, John Baillie, Marvin Borzini

NOES: None

ABSENT: Ken Ekelund, Jason Smith

DocuSigned by:  
*Mike LeBarre*  
3DE98F68D10F4DB...  
BY: Mike LeBarre, Chair  
Board of Directors

DocuSigned by:  
*Ara Azhderian*  
1E182EEB49A2435  
ATTEST: Ara Azhderian  
General Manager



# County of Monterey

## Item No.7

### Board Report

Board of Supervisors  
Chambers  
168 W. Alisal St., 1st Floor  
Salinas, CA 93901

Legistar File Number: WRAG 24-043

March 18, 2024

**Introduced:** 3/12/2024

**Current Status:** Agenda Ready

**Version:** 1

**Matter Type:** WR General Agenda

Recommend that the Monterey County Water Resources Agency Board of Supervisors approve and authorize the General Manager of the Monterey County Water Resources Agency to accept a donation of funding for chain link fencing valued at \$4,500 from Cypress Creek Apartments.  
(Staff: Mallory Roberts)

#### RECOMMENDATION:

It is recommended that the Monterey County Water Resources Agency Board of Directors:

Recommend that the Monterey County Water Resources Agency Board of Supervisors approve and authorize the General Manager of the Monterey County Water Resources Agency to accept a donation of funding for chain link fencing valued at \$4,500 from Cypress Creek Apartments.

#### SUMMARY/DISCUSSION:

The Monterey County Water Resources Agency (MCWRA) is responsible for the operations and maintenance of portions of the Reclamation Ditch mainstream, tributaries, and five pump stations. Within the City of Salinas (City), a portion of the Reclamation Ditch had a lack of enclosure, leading to entering of trash in the waterway. This has led to a scattering of trash, debris, and human waste which leads to pollution and creates a serious health, life, and safety hazard.

The purpose of the fencing work was to clear and keep trash away from the ditch, with the goal of improving and maintaining water quality in compliance with federal and state trash laws. The MCWRA carried out the fencing work with partial grant funds made available by the City for homelessness encampment resolution and that the type of fencing work consisted of steel chain link fencing. The fence is 160 feet in length and was initially bid \$9,000.00. The work was performed by Cypress Coast Fencing, and work commenced on January 11th, 2024. Cost of work was totaled at \$10,419.00.

MCWRA proposed that Cypress Creek Apartments, managed by Greystar Business Services, help to fund the project, as it benefits the residents of the apartments by enclosing the private property and stopping the discarding of trash, debris, and human waste. MCWRA asked Cypress Creek Apartments to assist with funding by means of a 50/50 split of the initial bid, an offer which Cypress Creek Apartments accepted. This resulted in the donation of \$4,500.00.

The MCWRA Board of Supervisors is empowered to accept this gift in order to serve a public purpose, here, operation of the Reclamation Ditch and protection of water quality. If the MCWRA Board of Supervisors authorizes acceptance of the donated funding, the Operations Division of the

MCWRA has an opportunity to improve existing conditions of the Reclamation Ditch at Casentini Street at minimal cost to the MCWRA.

The Fair Political Practices Commission (FPPC) requires, by regulation, that local officials that accept gifts for local agency purposes document the transaction and post information about the transaction on the agency website if the fair market value is worth more than \$2,500. Upon approval of acceptance of the donation, the MCWRA will comply with the FPPC regulation and will post the appropriate information on the MCWRA website.

OTHER AGENCY INVOLVEMENT:

County Counsel has reviewed and assisted with this donation.

FINANCING:

The expense and reimbursement for the fence will fall within the FY 23-24 approved budget for the Reclamation Ditch, Fund 122.

Prepared by: Mallory Roberts, Water Resources Hydrologist

Approved by: Ara Azhderian, General Manager

Attachment:

1. Letter to Cypress Creek Apartments Proposing Split Funding Effort
2. Letter fence work Cypress Creek ownership approval
3. Before and After Photos



# County of Monterey

**Item No.7**

Board of Supervisors  
Chambers  
168 W. Alisal St., 1st Floor  
Salinas, CA 93901

## Board Report

**Legistar File Number: WRAG 24-043**

**March 18, 2024**

**Introduced:** 3/12/2024

**Current Status:** Agenda Ready

**Version:** 1

**Matter Type:** WR General Agenda

Recommend that the Monterey County Water Resources Agency Board of Supervisors approve and authorize the General Manager of the Monterey County Water Resources Agency to accept a donation of funding for chain link fencing valued at \$4,500 from Cypress Creek Apartments.

### RECOMMENDATION:

It is recommended that the Monterey County Water Resources Agency Board of Directors:

Recommend that the Monterey County Water Resources Agency Board of Supervisors approve and authorize the General Manager of the Monterey County Water Resources Agency to accept a donation of funding for chain link fencing valued at \$4,500 from Cypress Creek Apartments.

### SUMMARY/DISCUSSION:

The Monterey County Water Resources Agency (MCWRA) is responsible for the operations and maintenance of portions of the Reclamation Ditch mainstream, tributaries, and five pump stations. Within the City of Salinas (City), a portion of the Reclamation Ditch had a lack of enclosure, leading to entering of trash in the waterway. This has led to a scattering of trash, debris, and human waste which leads to pollution and creates a serious health, life, and safety hazard.

The purpose of the fencing work was to clear and keep trash away from the ditch, with the goal of improving and maintaining water quality in compliance with federal and state trash laws. The MCWRA carried out the fencing work with partial grant funds made available by the City for homelessness encampment resolution and that the type of fencing work consisted of steel chain link fencing. The fence is 160 feet in length and was initially bid \$9,000.00. The work was performed by Cypress Coast Fencing, and work commenced on January 11th, 2024. Cost of work was totaled at \$10,419.00.

MCWRA proposed that Cypress Creek Apartments, managed by Greystar Business Services, help to fund the project, as it benefits the residents of the apartments by enclosing the private property and stopping the discarding of trash, debris, and human waste. MCWRA asked Cypress Creek Apartments to assist with funding by means of a 50/50 split of the initial bid, an offer which Cypress Creek Apartments accepted. This resulted in the donation of \$4,500.00.

The MCWRA Board of Supervisors is empowered to accept this gift in order to serve a public purpose, here, operation of the Reclamation Ditch and protection of water quality. If the MCWRA Board of Supervisors authorizes acceptance of the donated funding, the Operations Division of the MCWRA has an opportunity to improve existing conditions of the Reclamation Ditch at Casentini Street at minimal cost to the MCWRA.

The Fair Political Practices Commission (FPPC) requires, by regulation, that local officials that accept gifts for local agency purposes document the transaction and post information about the transaction on the agency website if the fair market value is worth more than \$2,500. Upon approval of acceptance of the donation, the MCWRA will comply with the FPPC regulation and will post the appropriate information on the MCWRA website.

OTHER AGENCY INVOLVEMENT:

County Counsel has reviewed and assisted with this donation.

FINANCING:

The expense and reimbursement for the fence will fall within the FY 23-24 approved budget for the Reclamation Ditch, Fund 122.

Prepared by: Mallory Roberts, Water Resources Hydrologist

Approved by: Ara Azhderian, General Manager

Attachment:

1. Letter to Cypress Creek Apartments Proposing Split Funding Effort
2. Letter fence work Cypress Creek ownership approval
3. Before and After Photos

# MONTEREY COUNTY

---

## WATER RESOURCES AGENCY



PO BOX 930  
SALINAS, CA 93902  
P: (831) 755-4860  
F: (831) 424-7935

ARA AZHDERIAN  
GENERAL MANAGER

STREET ADDRESS  
1441 SCHILLING PLACE, NORTH BUILDING  
SALINAS, CA 93901

January 11, 2024

Cypress Creek Apartments  
Attn: Mark Washington, Manager  
162 Casentini Street, Salinas, CA 93907

RE: Notice to Contribute for Fencing Work

Dear Mr. Washington:

I am writing with regard to fencing work proposed in respect to our adjoining lands located near 105 Casentini Street in the City of Salinas, APN 003-191-011-000 (your "PROPERTY"). The Monterey County Water Resources Agency (MCWRA) is proposing that fencing work be carried out on the common boundary of our lands and that the type of fencing work consist of steel chain link fencing. The fence to be constructed would be 160 feet in length and the estimated cost of the fencing work is \$9,000.00. The MCWRA proposes that the cost of the fence be shared equally between us in the following proportions of 50/50, and that you contribute \$4,500.00 and the Agency contribute \$4,500.00. A copy of one (1) written quotation specifying the estimated cost of the fencing work is attached. If you agree to this proposal, please complete the attached "Agreement to contribute to fencing work" and return a signed copy of the agreement to the Agency within one (1) month of the date of this notice if given to you to the following address:

1441 Schilling Place, North Building, Salinas CA 93901

Please let the Agency know within one (1) month of the day this notice is given to you if you do not agree to this proposal.

The purpose of the fencing work is to clear and keep trash away from the reclamation ditch, with the goal of improving and maintaining water quality in compliance with federal and state trash laws. As adjoining owners, this is an attempt to resolve issues about fencing work and the trash enclosure to avoid a dispute arising. It has been reported that the parcel currently has a lack of enclosure, allowing for the entering of trash into the waterway. This has led to a scattering of trash, debris, and human waste which leads to pollution and creates a serious health, life, and safety hazard.

**The fencing project is expected to commence on January 11<sup>th</sup>, 2024.**

We request that Cypress Creek Apartments please accept this proposal and will consider assisting in the funding for this fencing work project.

Sincerely,

Jennifer Bodensteiner  
Associate Hydrologist – MCWRA Operations

The Water Resources Agency manages water resources sustainably while minimizing impacts from flooding for present and future generations.

## AGREEMENT TO CONTRIBUTE WORK TO FENCING

We the adjoining owner/s acknowledge receipt of the Notice to contribute for fencing work and agree/disagree to contribute to the fencing work.

We agree to contribute to the fencing work as follows:

We will pay our contribution to you/the fencing contractor as follows:

Full Name:

Address:

Signatures:

X

---

Date:

PLEASE KEEP A COPY OF THIS AGREEMENT FOR YOUR RECORDS AND MAKE A NOTE OF THE DATE THIS SIGNED AGREEMENT WAS GIVEN TO YOUR NEIGHBOR.



Cypress Coast Fence  
 836 Walker Street  
 Watsonville, CA 95076  
 831-783-1500  
 www.cypresscoastfence.com

# Job Layout Proposal

Date	Proposal #
12/27/2023	23-09-617-4

Name / Address
Don Chapin

Description	Qty	Rate	Total	Labor Warranty	Material Warranty	Rep
				5 Years	5 Years	KT
<b>NEW FENCE BEHIND APTS.</b>						
INSTALL 160 LF OF 6' TALL GALVANIZED CHAIN LINK FENCE.	160	51.00	8,160.00			
SPECIFICATIONS FENCE TO SLOPE WITH GRADE. END & CORNER POSTS: 2 3/8" SC40 GALVANIZED SET IN 2' OF CONCRETE. LINE POSTS: 2 3/8" SC40 GALVANIZED ON 10' MAX CENTERS, SET IN 2' OF CONCRETE. NO TOP RAIL. FABRIC: 6' TALL 9GA GALVANIZED KK.						
INSTALL 2 END H-BRACES FOR SUPPORT.	2	450.00	900.00			
CLIENT TO GRADE LOCATION BEFORE CCF INSTALL AS DISCUSSED DURING SITE VISIT WITH ESTIMATOR.		0.00	0.00			
				CONTRACTOR +15% = 1,359 $\frac{9,060}{10,419}$		
Estimate valid for 5 days. Price subject to change.				<b>Total</b>		



**From:** [Cypress Creek Salinas Manager](#)  
**To:** [Bodensteiner, Jennifer M.](#)  
**Subject:** RE: Fence work at Casentini Street and apartments  
**Date:** Tuesday, January 30, 2024 11:54:06 AM

---

[CAUTION: This email originated from outside of the County. Do not click links or open attachments unless you recognize the sender and know the content is safe. ]

Hi Jennifer,

Just following up on my phone message to you letting you know that ownership has approved the \$4,500.00 proposed contribution. Please scroll through your emails and see if you can locate one from TruAmerica or Vendor Credentialing. This is to make your office a vendor so we can submit a check.

Please let me know what questions you may have,

Thanks,

Mark

**Mark Washington** | Community Manager  
**Cypress Creek** | 162 Casentini Street | Salinas, CA 93907  
o 831.758.3008 | f 831.758.0682 | [cypress\\_salinasmgr@greystar.com](mailto:cypress_salinasmgr@greystar.com)  
[www.cypresscreekliving.com](http://www.cypresscreekliving.com)

Proudly managed by [Greystar](#)®

---

**From:** Bodensteiner, Jennifer M. <[BodensteinerJM@co.monterey.ca.us](mailto:BodensteinerJM@co.monterey.ca.us)>  
**Sent:** Thursday, January 11, 2024 2:53 PM  
**To:** Cypress Creek Salinas Manager <[cypress\\_salinasmgr@greystar.com](mailto:cypress_salinasmgr@greystar.com)>  
**Subject:** [EXTERNAL] Fence work at Casentini Street and apartments

Dear Mr. Washington:

It was good speaking with you in December 2023 and discussing the needs of fencing at Casentini Street.

I understand the issues our maintenance staff are facing with trash and how fence work will improve the area.

As discussed, I have attached a letter to inform you of fence work and how we can work together to construct the boundary fence.

Let me know if you have any questions, and I would be more than happy to speak again or follow up

with an in-person meeting. If not, I look forward to a reply on the fence work scheduled to begin today January 11, 2024.

Thank you.

Sincerely,

Jennifer Bodensteiner  
Associate Hydrologist, Monterey County Water Resources Agency  
mobile: (831) 788-3514  
phone: (831) 755-4970  
email: [bodensteinerjm@co.monterey.ca.us](mailto:bodensteinerjm@co.monterey.ca.us)

1441 Schilling Place, North Building  
Salinas, CA 93901



[www.mcwater.info](http://www.mcwater.info)



Prior to fencing work @ Cypress Creek Apartments – November 2023

After Fencing  
work @  
Cypress Creek  
Apartments –  
January 2024





***Before the Board of Directors of the Monterey County Water Resources Agency***

***County of Monterey, State of California***

BOARD ORDER No. \_\_\_\_

RECOMMEND THAT THE MONTEREY COUNTY WATER RESOURCES )  
BOARD OF SUPERVISORS APPROVE AND AUTHORIZE THE GENERAL )  
MANAGER OF THE MONTEREY COUNTY WATER RESOURCES )  
AGENCY TO ACCEPT A DONATION OF FUNDING FOR CHAIN LINK )  
FENCING VALUED AT \$4,500.00 FROM CYPRESS CREEK APARTMENTS )

Upon motion of Director \_\_\_\_\_, seconded by Director \_\_\_\_\_, and carried by those members present, the Board of Directors hereby:

Recommend that the Monterey County Water Resources Agency Board of Supervisors approve and authorize the General Manager of the Monterey County Water Resources Agency to accept a donation of funding for chain link fencing valued at \$4,500.00 from Cypress Creek Apartments.

PASSED AND ADOPTED on this **18th** of **March 2024**, by the following vote, to-wit:

AYES:

NOES:

ABSENT:

\_\_\_\_\_  
BY: Mike LeBarre, Chair  
Board of Directors

\_\_\_\_\_  
ATTEST: Ara Azhderian  
General Manager



***Before the Board of Directors of the Monterey County Water Resources Agency***  
***County of Monterey, State of California***

BOARD ORDER No. 24-007

RECOMMEND THAT THE MONTEREY COUNTY WATER RESOURCES )  
BOARD OF SUPERVISORS APPROVE AND AUTHORIZE THE GENERAL )  
MANAGER OF THE MONTEREY COUNTY WATER RESOURCES )  
AGENCY TO ACCEPT A DONATION OF FUNDING FOR CHAIN LINK )  
FENCING VALUED AT \$4,500.00 FROM CYPRESS CREEK APARTMENTS )

Upon motion of Director John Baillie, seconded by Director Mark Gonzalez, and carried by those members present, the Board of Directors hereby:

Recommend that the Monterey County Water Resources Agency Board of Supervisors approve and authorize the General Manager of the Monterey County Water Resources Agency to accept a donation of funding for chain link fencing valued at \$4,500.00 from Cypress Creek Apartments.

PASSED AND ADOPTED on this **18th** of **March 2024**, by the following vote, to-wit:

AYES: Mike LeBarre, Matt Simis, Mark Gonzalez, Deidre Sullivan, Mike Scattini, John Baillie, Marvin Borzini

NOES: None

ABSENT: Ken Ekelund, Jason Smith

DocuSigned by:  
*Mike LeBarre*  
3DE98F68D10F4DB...

BY: Mike LeBarre, Chair  
Board of Directors

DocuSigned by:  
*Ara Azhderian*  
1F182FFB49A2435

ATTEST: Ara Azhderian  
General Manager



# County of Monterey

## Item No.8

### Board Report

Board of Supervisors  
Chambers  
168 W. Alisal St., 1st Floor  
Salinas, CA 93901

Legistar File Number: WRAG 24-044

March 18, 2024

**Introduced:** 3/12/2024

**Current Status:** Agenda Ready

**Version:** 1

**Matter Type:** WR General Agenda

Approve an Intellectual Property Rights Transfer Agreement with the Grower-Shipper Association of Central California, Inc. for an updated flood model of the Salinas River, and authorize the General Manager to execute the Agreement. (Staff: Ara Azhderian)

#### RECOMMENDATION:

It is recommended that the Board of Directors of the Monterey County Water Resources Agency:

Approve an Intellectual Property Rights Transfer Agreement with the Grower-Shipper Association of Central California, Inc. for an updated flood model of the Salinas River, and authorize the General Manager to execute the Agreement.

#### SUMMARY/DISCUSSION:

Following the Salinas River flood events of March 2023, the Grower-Shipper Association of Central California, Inc. engaged Flow West to update the Hydrologic Engineering Center River Analysis System (HEC-RAS) model developed by the United States Army Corps of Engineers and to analyze those events to help inform future decisions regarding the channel maintenance of the Salinas River. The Water Resources Agency participated in the effort by providing technical review and advice. Upon completion of the HEC-RAS model update, the Grower-Shipper Association requested the Agency assume control of the model in order to provide public access, periodic updates, and other potential improvements, such as future storm event forecasting. Given the Agency's ongoing reservoir operations and flood management responsibilities in the Salinas River, as well as its collaboration with the Resources Conservation District of Monterey County on the Stream Maintenance Program, it is appropriate for the Agency to receive the updated model, maintain it, and provide access to its analytical capabilities to affiliated agencies and the public.

#### OTHER AGENCY INVOLVEMENT:

None

#### FINANCING:

None

Prepared and Approved by: Ara Azhderian, General Manager, (831) 755-4860

Attachments:

1. Intellectual Property Transfer Agreement

2. Board Order



# County of Monterey

**Item No.8**

## Board Report

Board of Supervisors  
Chambers  
168 W. Alisal St., 1st Floor  
Salinas, CA 93901

**Legistar File Number: WRAG 24-044**

**March 18, 2024**

**Introduced:** 3/12/2024

**Current Status:** Agenda Ready

**Version:** 1

**Matter Type:** WR General Agenda

Approve an Intellectual Property Rights Transfer Agreement with the Grower-Shipper Association of Central California, Inc. for an updated flood model of the Salinas River, and authorize the General Manager to execute the Agreement.

RECOMMENDATION:

It is recommended that the Board of Directors of the Monterey County Water Resources Agency:

Approve an Intellectual Property Rights Transfer Agreement with the Grower-Shipper Association of Central California, Inc. for an updated flood model of the Salinas River, and authorize the General Manager to execute the Agreement.

SUMMARY/DISCUSSION:

Following the Salinas River flood events of March 2023, the Grower-Shipper Association of Central California, Inc. engaged Flow West to update the Hydrologic Engineering Center River Analysis System (HEC-RAS) model developed by the United States Army Corps of Engineers and to analyze those events to help inform future decisions regarding the channel maintenance of the Salinas River. The Water Resources Agency participated in the effort by providing technical review and advice. Upon completion of the HEC-RAS model update, the Grower-Shipper Association requested the Agency assume control of the model in order to provide public access, periodic updates, and other potential improvements, such as future storm event forecasting. Given the Agency's ongoing reservoir operations and flood management responsibilities in the Salinas River, as well as its collaboration with the Resources Conservation District of Monterey County on the Stream Maintenance Program, it is appropriate for the Agency to receive the updated model, maintain it, and provide access to its analytical capabilities to affiliated agencies and the public.

OTHER AGENCY INVOLVEMENT:

None

FINANCING:

None

Prepared and Approved by: Ara Azhderian, General Manager, (831) 755-4860

Attachments:

1. Intellectual Property Transfer Agreement

2. Board Order

## INTELLECTUAL PROPERTY RIGHTS TRANSFER AGREEMENT

This Intellectual Property Rights Transfer Agreement (“Agreement”) is entered into as of March 1, 2024 (“Effective Date”), by and between Grower Shipper Association of Central California, Inc., a California nonprofit corporation (“GSA”) and Monterey County Water Resources Agency (“MCWRA”). GSA and MCWRA may be referred to individually as a “Party” and collectively as the “Parties.” The Parties agree as follows:

### 1. Recitals.

1.1 GSA is an association whose members are engaged in agricultural production in Central California.

1.2 MCWRA is a special act agency of the State of California with duties and responsibilities set forth in Chapter 52 of the California Water Code Appendix, and is the successor to the Monterey County Flood Control and Water Conservation District.

1.3 GSA engaged FlowWest to analyze Salinas River hydraulics during March 2023 flood events that caused significant damage to its members and other landowners in the Salinas Valley. This effort required development of updates to a hydraulic computer model (“Model”) of the Salinas River from approximately Bradley to the Monterey Bay created by FlowWest (FlowWest 2015) in support of the Channel Maintenance Program (now known as the “SMP” or “Stream Maintenance Program”).

1.4 GSA desires to transfer ownership of the updates to the Model (“Intellectual Property”) to MCWRA for further development and implementation of SMP activities with SMP partners.

2. Transfer of Intellectual Property. Subject to the terms and conditions of this Agreement, for good and valuable consideration receipt of which is acknowledged, as of the Effective Date GSA transfers and assigns the Intellectual Property to MCWRA, and MCWRA accepts such transfer and assignment.

3. Use of Intellectual Property. MCWRA shall use best efforts to utilize the Intellectual Property as follows:

- Use the Intellectual Property in a way that is consistent with MCWRA’s obligations relating to reservoir operations and flood management.
- To maintain and update the Intellectual Property to continue to support flood forecasting and flood risk management projections as is reasonably practicable for such activities.

4. Representations of GSA. GSA represents to MCWRA as follows:

4.1 Organization, Standing, and Authority. GSA is a non-profit corporation duly organized under the laws of the State of California.

4.2 Authorization of Agreement; Authority. The execution, delivery and performance of this Agreement by GSA has been duly authorized by all necessary corporate action of GSA, and this Agreement constituted the valid and binding obligation of GSA, enforceable in accordance with its terms.

4.3 Ownership of Intellectual Property. GSA is the sole owner of the Intellectual Property and no third party has any claim, right or interest therein.

4.4 Litigation, Compliance with Laws. There are no judicial or administrative actions, proceedings or investigations pending or, to the best of GSA's knowledge, threatened, that question the validity of this Agreement, or any action taken or to be taken by GSA in connection with this Agreement.

5. Representations of MCWRA. MCWRA represents to GSA as follows:

5.1 Authorization of Agreement; Authority. The execution, delivery and performance of this Agreement by GSA has been duly authorized by all necessary action of MCWRA, and this Agreement constituted the valid and binding obligation of GSA, enforceable in accordance with its terms.

5.2 Litigation, Compliance with Laws. There are no judicial or administrative actions, proceedings or investigations pending or, to the best of MCWRA's knowledge, threatened, that question the validity of this Agreement, or any action taken or to be taken by MCWRA in connection with this Agreement.

6. No Warranty. GSA makes no representation or warranty regarding the Intellectual Property and/or its content. GSA shall have no obligation or liability regarding MCWRA's use of the Intellectual Property or the success or failure of any policy or act taken by MCWRA. MCWRA shall indemnify and hold harmless GSA from any claim arising out of MCWRA's use of the Intellectual Property.

7. General Provisions.

7.1 Amendment. This Agreement may not be amended, modified or supplemented except by a written agreement executed by all the Parties.

7.2 Assignment. No assignment or transfer by any Party of their respective rights and obligations hereunder shall be made except with the prior written consent of the other Party.

7.3 Attorneys' Fees. In the event any Party institutes an action or proceeding to enforce any rights arising under this Agreement, the Party prevailing in such action or proceeding shall be paid all reasonable attorneys' fees and costs.

7.4 Binding Effect. This Agreement shall be binding upon and shall inure to the benefit of the Parties and their permitted successors and assigns, and any reference to a Party hereto shall also be a reference to a permitted successor or assign.

7.5 Captions. The titles and captions contained in this Agreement are inserted herein only as a matter of convenience and for reference and in no way define, limit, extend or describe the scope of this Agreement or the intent of any provision hereof.

7.6 Complete Agreement. This Agreement constitutes the complete and exclusive statement of agreement among the Parties with respect to the subject matter herein and therein replace and supersede all prior written and oral agreements or statements by and among the Parties. Civil Code section 1698 does not apply to this Agreement.

7.7 Controlling Law. This Agreement shall be governed by and construed and enforced in accordance with the internal laws of the State of California.

7.8 Exhibits. The Exhibits attached hereto are incorporated into and made a part of this Agreement

as if set out in full in this Agreement.

7.9 Jurisdiction and Venue. The making of this Agreement is in Monterey County, California.

7.10 Notices. All notices and other communications to be made pursuant to this Letter shall be in writing and shall be deemed to have been duly given on the date of service, if served personally on the party to whom service is given, or on the second day after mailing, if mailed to the party to whom notice is to be given, by first class mail, registered or certified, postage prepaid and properly addressed as follows:

Grower-Shipper Association of Central California  
512 Pajaro Street  
Salinas, CA 93901  
Contact: *Christopher Valadez, President*

Monterey County Water Resources Agency  
1441 Schilling Place, North Bldg.  
Salinas, CA 93901  
Contact: Jason Demers, Senior Water Resources Engineer - Operations

or to such other representative or at such other address of a Party as such Party hereto may furnish to the other Parties in writing.

7.11 Representation. The Parties have had the opportunity to be represented by independent legal counsel of its own choice, and this Agreement was prepared with the joint input of all Parties and shall not be construed in favor of or against any party to the Agreement. The Parties further acknowledge that this Agreement was executed freely and voluntarily and with the opportunity for each Party to receive the advice of independent legal counsel.

7.12 Severability. The unenforceability, invalidity or illegality of any provision of this Agreement shall not render the other provisions unenforceable, invalid, or illegal. If any provision of the Agreement is held invalid or unenforceable, then the remainder of this Agreement shall nevertheless remain in full force and effect.

7.13 Waiver. A waiver by one Party of the performance of any covenant, agreement, obligation, condition, representation or warranty shall not be construed as a waiver of any other covenant, agreement, obligation, condition, representation or warranty. A waiver by any Party of the performance of any act shall not constitute a waiver of the performance of any other act or an identical act required to be performed at a later time.

**IN WITNESS WHEREOF**, Parties intend to be legally bound and have caused this Agreement to be executed as of the last date of signature.

*[Signatures on following page]*

**MONTEREY COUNTY WATER RESOURCES AGENCY**

By: \_\_\_\_\_

Name: Ara Azhderian  
Title: General Manager

Date: \_\_\_\_\_

**GROWER SHIPPER ASSOCIATION OF CENTRAL CALIFORNIA, INC.**

By: Christopher Valadez

Name: Christopher Valadez  
Title: President

Date: 3-1-2024



***Before the Board of Directors of the Monterey County Water Resources Agency  
County of Monterey, State of California***

BOARD ORDER No. \_\_\_\_\_

**APPROVE AN INTELLECTUAL PROPERTY RIGHTS TRANSFER )  
AGREEMENT WITH THE GROWER-SHIPPER ASSOCIATION )  
OF CENTRAL CALIFORNIA, INC. FOR AN UPDATED FLOOD )  
MODEL OF THE SALINAS RIVER, AND AUTHORIZE THE )  
GENERAL MANAGER TO EXECUTE THE AGREEMENT. )**

Upon motion of Director \_\_\_\_\_, seconded by Director \_\_\_\_\_, and carried by those members present, the Board of Directors hereby:

1. Approves an Intellectual Property Rights Transfer Agreement with the Grower-Shipper Association of Central California, Inc. for an updated flood model of the Salinas River.
2. Authorizes the General Manager to execute the Agreement.

PASSED AND ADOPTED on this **18th** day of **March 2024**, by the following vote, to-wit:

\_\_\_\_\_  
BY: Mike LeBarre, Chair  
Board of Directors

\_\_\_\_\_  
ATTEST: Ara Azhderian  
General Manager



***Before the Board of Directors of the Monterey County Water Resources Agency  
County of Monterey, State of California***

BOARD ORDER No. 24-008

**APPROVE AN INTELLECTUAL PROPERTY RIGHTS TRANSFER )  
AGREEMENT WITH THE GROWER-SHIPPER ASSOCIATION )  
OF CENTRAL CALIFORNIA, INC. FOR AN UPDATED FLOOD )  
MODEL OF THE SALINAS RIVER, AND AUTHORIZE THE )  
GENERAL MANAGER TO EXECUTE THE AGREEMENT. )**

Upon motion of Director John Baillie, seconded by Director Mark Gonzalez, and carried by those members present, the Board of Directors hereby:

1. Approves an Intellectual Property Rights Transfer Agreement with the Grower-Shipper Association of Central California, Inc. for an updated flood model of the Salinas River.
2. Authorizes the General Manager to execute the Agreement.

PASSED AND ADOPTED on this **18th** day of **March 2024**, by the following vote, to-wit:

AYES: Mike LeBarre, Matt Simis, Mark Gonzalez, Deidre Sullivan, Mike Scattini, John Baillie, Marvin Borzini

NOES: None

ABSENT: Ken Ekelund, Jason Smith

DocuSigned by:  
  
3DE98E68D10E4DB

---

BY: Mike LeBarre, Chair  
Board of Directors

DocuSigned by:  
  
1E182FFB49A2435

---

ATTEST: Ara Azhderian  
General Manager



# County of Monterey

## Item No.9

### Board Report

Board of Supervisors  
Chambers  
168 W. Alisal St., 1st Floor  
Salinas, CA 93901

**Legistar File Number: WRAG 24-037**

**March 18, 2024**

**Introduced:** 3/12/2024

**Current Status:** Draft

**Version:** 1

**Matter Type:** WR General Agenda

March, April and May 2024 Calendars.

# March 2024

March 2024							April 2024						
Su	Mo	Tu	We	Th	Fr	Sa	Su	Mo	Tu	We	Th	Fr	Sa
3	4	5	6	7	8	9	7	8	9	10	11	12	13
10	11	12	13	14	15	16	14	15	16	17	18	19	20
17	18	19	20	21	22	23	21	22	23	24	25	26	27
24	25	26	27	28	29	30	28	29	30				
31													

SUNDAY	MONDAY	TUESDAY	WEDNESDAY	THURSDAY	FRIDAY	SATURDAY
Feb 25	26	27	28	29	Mar 1 8:30am Personnel & Administration 10:00am Finance 12:00pm "Building"	2
3	4	5	6 10:00am Planning Committee-2023-12 ( <a href="https://montereycty.zoom.us/j/9551198242">https://montereycty.zoom.us/j/9551198242</a> )	7	8	9
10	11	12	13	14	15	16
17	18 Board of Directors Meeting - 930-Board 12:00pm Board of Directors	19	20	21	22	23
24	25	26	27	28 1:30pm Reservoir Operations Advisory Committee - 2024 ( <a href="https://montereycty.zoom.us/j/9551198242">https://montereycty.zoom.us/j/9551198242</a> )	29	30
31	Apr 1	2	3	4	5	6

# April 2024

April 2024							May 2024						
Su	Mo	Tu	We	Th	Fr	Sa	Su	Mo	Tu	We	Th	Fr	Sa
7	8	9	10	11	12	13	5	6	7	8	9	10	11
14	15	16	17	18	19	20	12	13	14	15	16	17	18
21	22	23	24	25	26	27	19	20	21	22	23	24	25
28	29	30					26	27	28	29	30	31	

SUNDAY	MONDAY	TUESDAY	WEDNESDAY	THURSDAY	FRIDAY	SATURDAY
Mar 31	Apr 1	2	3 8:30am Basin Management Advisory Committee - 10:00am Planning Committee-2023-12 ( <a href="https://montereycty.z">https://montereycty.z</a> )	4	5 8:30am Personnel & Administration Committee-2023-11 10:00am Finance Committee-2023-11 ( <a href="https://montereycty.z">https://montereycty.z</a> )	6
7	8	9	10	11 8:30am All Hands Meeting ( <a href="https://montereycty.zoom.us/j/99159079837?pwd=OWc4YUthSGRBS2lvdVplYWg2cm">https://montereycty.zoom.us/j/99159079837?pwd=OWc4YUthSGRBS2lvdVplYWg2cm</a> )	12	13
14	15 Board of Directors Meeting - 930-Board of Directors 12:00pm Board of Directors Meeting-2022-3	16	17	18	19	20
21	22	23	24	25 11:00am Joint Water Resources/Board of Supervisors 1:30pm Reservoir Operations Advisory Committee - 2024	26	27
28	29	30	May 1	2	3	4

# May 2024

May 2024							June 2024						
Su	Mo	Tu	We	Th	Fr	Sa	Su	Mo	Tu	We	Th	Fr	Sa
			1	2	3	4							1
5	6	7	8	9	10	11	2	3	4	5	6	7	8
12	13	14	15	16	17	18	9	10	11	12	13	14	15
19	20	21	22	23	24	25	16	17	18	19	20	21	22
26	27	28	29	30	31		23	24	25	26	27	28	29
							30						

SUNDAY	MONDAY	TUESDAY	WEDNESDAY	THURSDAY	FRIDAY	SATURDAY
Apr 28	29	30	<b>May 1</b> 8:30am Basin Management Advisory Committee - 10:00am Planning Committee-2023-12 <a href="https://montereycty.z">https://montereycty.z</a>	2	3 8:30am Personnel & Administration Committee-2023-11 10:00am Finance Committee-2023-11 <a href="https://montereycty.z">https://montereycty.z</a>	4
5	6	7	8	9	10	11
12	13	14	15	16	17	18
19	Board of Directors Meeting - 930-Board of Directors 12:00pm Board of Directors Meeting-2022-3	21	22	23 8:30am All Hands Meeting <a href="https://montereycty.z">https://montereycty.z</a> <a href="https://montereycty.z/j/99159079837?pwd=OWc4YUtHSGRBS2lvdVplYWg2cm">oom.us/j/99159079837?pwd=OWc4YUtHSGRBS2lvdVplYWg2cm</a>	24	25
26	27	28	29	30 1:30pm Reservoir Operations Advisory Committee - 2024 <a href="https://montereycty.z">https://montereycty.z</a> <a href="https://montereycty.z/j/92085702216?pwd=RzQ0R1RNaU">oom.us/j/92085702216?pwd=RzQ0R1RNaU</a>	31	Jun 1



# County of Monterey

**Item No.10**

## Board Report

Board of Supervisors  
Chambers  
168 W. Alisal St., 1st Floor  
Salinas, CA 93901

**Legistar File Number: WRAG 24-038**

**March 18, 2024**

**Introduced:** 3/12/2024

**Current Status:** Draft

**Version:** 1

**Matter Type:** WR General Agenda

- Personnel Update
- Monterey One Reconciliation
- Carmel River Flood Model Update Funding
- Other



# County of Monterey

**Item No.11**

## Board Report

Board of Supervisors  
Chambers  
168 W. Alisal St., 1st Floor  
Salinas, CA 93901

**Legistar File Number: WRAG 24-039**

**March 18, 2024**

**Introduced:** 3/12/2024

**Current Status:** Draft

**Version:** 1

**Matter Type:** WR General Agenda

Committee Agenda's and Cancellation Notices for February and March 2024:

- Water Resources Agency Reservoir Operations Advisory Committee
- Water Resources Agency Personnel and Administration Committee
- Water Resources Finance Committee
- Water Resources Agency Basin Management Advisory Committee
- Water Resources Planning Committee

# County of Monterey

Saffron Room  
1441 Schilling Place 1st Floor  
Salinas, CA 93901



## Meeting Agenda

Thursday, February 29, 2024

1:30 PM

IN-PERSON MEETING

### Water Resources Agency Reservoir Operations Advisory Committee

*John Baillie, Chair*

*Ken Ekelund*

*Mark Gonzalez*

*Matthew Simis*

*Jon Anthony*

*Bill Lipe*

*Wes Thomson*

*Layla Decker*

*Richard Ortiz*

*Matthew Panziera*

*Eric Morgan*

*Kevin Piearcy*

*Marc Kelley*

*Doug Scattini*

*Zach Barnes*

*Steve Blois*

*Vacancy (1)*

To participate in this Reservoir Operations Advisory Committee meeting through the following methods:

1. You may attend in person,
2. If you wish to comment on a particular agenda item, please submit your comments in writing via email to Monterey County Water Resources Agency at [WRAPubliccomment@co.monterey.ca.us](mailto:WRAPubliccomment@co.monterey.ca.us) by 5:00 p.m. on the Wednesday prior to the Committee meeting. To assist Agency staff in identifying the agenda item to which the comment relates please indicate the Reservoir Operations Advisory Committee meeting date and agenda number in the subject line. Comments received by the 5:00 p.m. Wednesday deadline will be distributed to the Committee and will be placed in the record.
3. If you wish to make either a general public comment for items not on the day's agenda or to comment on a specific agenda item as it is being heard, please submit your comment, limited to 250 words or less, to the Monterey County Water Resources Agency at [WRAPubliccomment@co.monterey.ca.us](mailto:WRAPubliccomment@co.monterey.ca.us). In an effort to assist Agency staff in identifying the agenda item relating to your public comment please indicate in the subject line, the meeting body (i.e. Reservoir Operations Advisory Committee) and item number (i.e. Item No. 10). Every effort will be made to read your comment into the record, but some comments may not be read due to time limitations. Comments received after an agenda item will be made part of the record if received prior to the end of the meeting.
4. If speakers or other members of the public have documents they wish to distribute to the Committee for an agenda item, they are encouraged to submit such documents by 5:00 p.m. on Wednesday before the meeting to: [WRAPubliccomment@co.monterey.ca.us](mailto:WRAPubliccomment@co.monterey.ca.us). To assist Agency staff in identifying the agenda item to which the comment relates, the public is requested to indicate the Reservoir Operations Advisory Committee date and agenda number in the subject line.
5. If members of the public want to present documents/Power Point presentations while speaking, they should submit the document electronically by 5:00 p.m. on Wednesday before the meeting at [WRAPubliccomment@co.monterey.ca.us](mailto:WRAPubliccomment@co.monterey.ca.us). (If submitted after that deadline, staff will make best efforts, but cannot guarantee, to make it available to present during the Committee meeting.)
6. Individuals with disabilities who desire to request a reasonable accommodation or modification to observe or participate in the meeting may make such request by sending an email to [WRAPubliccomment@co.monterey.ca.us](mailto:WRAPubliccomment@co.monterey.ca.us). The request should be made no later than noon on the Wednesday prior to the Committee meeting in order to provide time for the Agency to address

the  
request.

**7. The Chair and/or Secretary may set reasonable rules as needed to conduct the meeting in an orderly manner.**

**Para participar en esta reunión del Comité Asesor de la Operación de Embalses a través de los siguientes métodos:**

- 1. Podrá asistir personalmente a la reunión; o,**
- 2. Si un miembro del público desea comentar sobre un artículo de la agenda en particular, se le es sumamente recomendable que envíe sus comentarios por escrito por correo electrónico a la Agencia de Administración de Recursos del Agua (Agencia) a [WRAPubliccomment@co.monterey.ca.us](mailto:WRAPubliccomment@co.monterey.ca.us) antes de las 5:00 P. M. el Miércoles antes de la reunión del Comité. Para ayudar al personal de la Agencia a identificar el número del artículo de la agenda con el cual se relaciona el comentario, se solicita al público que indique la fecha de la reunión del Comité y el número del artículo de la agenda en la línea de asunto. Comentarios recibidos en la fecha límite del Miércoles a las 5 P.M, serán distribuidos al Comité y serán colocados en el registro.**
- 3. Los miembros del público que deseen hacer un comentario público general para temas que no están en la agenda del día o que deseen comentar en un artículo específico mientras se escucha la presentación, lo pueden hacer enviando un comentario por correo electrónico, preferiblemente limitado a 250 palabras o menos, a [WRAPubliccomment@co.monterey.ca.us](mailto:WRAPubliccomment@co.monterey.ca.us). Para ayudar al personal de la Agencia a identificar el artículo de la agenda con el cual se relaciona el comentario, se solicita al público que indique el nombre del Comité (por ejemplo: Comité Asesor de la Operación de Embalses) y el número del artículo de la agenda (por ejemplo: Artículo # 10). Se hará todo lo posible para leer el comentario en el registro, pero algunos comentarios pueden no leerse en voz alta debido a limitaciones de tiempo. Los comentarios recibidos después del cierre del período de comentarios públicos sobre un artículo de la agenda serán parte del registro si se reciben antes que termine la reunión del Comité.**
- 4. Si los oradores u otros miembros del público tienen documentos que desean distribuir al Comité para un artículo de la agenda, se les recomienda enviar dichos documentos antes de las 5:00 P.M. el Miércoles antes de la reunión a: [WRAPubliccomment@co.monterey.ca.us](mailto:WRAPubliccomment@co.monterey.ca.us). Para ayudar al personal de la Agencia a identificar el número del artículo de la agenda con el cual se relaciona el comentario,**

se solicita al público que indique la fecha de la reunion del Comité y el número de agenda en la línea de asunto.

5. Si los miembros del público desean presentar documentos o presentaciones de PowerPoint mientras hablan, deben enviar el documento electrónicamente antes de las 5:00 P.M. del Miércoles antes de la reunión a [WRAPubliccomment@co.monterey.ca.us](mailto:WRAPubliccomment@co.monterey.ca.us) (Si se presenta después de ese plazo, el personal hará los mejores esfuerzos, pero no puede garantizar que esté disponible su PowerPoint para presentar durante la reunión del Comité).

6. Las personas con discapacidades que deseen solicitar una modificación o modificación razonable para observar o participar en la reunión pueden realizar dicha solicitud enviando un correo electrónico a [WRAPubliccomment@co.monterey.ca.us](mailto:WRAPubliccomment@co.monterey.ca.us). La solicitud debe hacerse a más tardar el mediodía del Miércoles antes de a la reunión del Comité para dar tiempo a la Agencia para que atienda la solicitud .

7. El Presidente y / o Secretario pueden establecer reglas razonables según sea necesario para llevar a cabo la reunión de manera ordenada.  
Call to Order

### Call to Order

### Roll Call

### Public Comment

### Committee Member Comments

### Consent Calendar

1. Approve the Minutes of the Reservoir Operations Advisory Committee meeting on January 25, 2024.

**Attachments:** [Draft ResOps Minutes January 25, 2024](#)

### Staff Reports

2. Reservoir Storage and Releases Update (Staff Presenting; Joseph Klein)

**Attachments:** [Reservoir Storage Release Update Report](#)  
[Reservoir Elevation and Storage Slides](#)

3. Current Operations and Maintenance Activities at the Reservoirs (Staff Presenting; Jason Demers)
4. Update on the San Antonio Spillway (Staff Presenting; Elise Ramirez)

**Status Reports**

5.
  - Lake Recreation by Concessionaire and Parks Department
  - San Luis Obispo County Activities
  - National Marine Fisheries Service
  - Quagga Mussel Update

**Calendar**

6. Set next meeting date and discuss future agenda items.

**Adjournment**



WATER RESOURCES AGENCY

MEMORANDUM

Monterey County

DATE: February 22, 2024

**PUBLIC MEETING CANCELLATION NOTICE**

**THE PERSONNEL & ADMINISTRATION  
COMMITTEE MEETING SCHEDULED FOR  
FRIDAY MARCH 1, 2024 @ 8:30 AM  
HAS BEEN CANCELLED.**

**THE NEXT MEETING IS SCHEDULED FOR  
FRIDAY APRIL 5, 2024 @ 8:30 AM**

**WATER RESOURCES AGENCY  
1441 SCHILLING PLACE  
SALINAS, CA**

# County of Monterey

*Saffron Room  
1441 Schilling Place, North Building  
Salinas, CA 93901*



## Meeting Agenda

**Friday, March 1, 2024**

**10:00 AM**

**IN-PERSON MEETING**

## **Water Resources Agency Finance Committee**

*John Baillie, Chair  
Mark Gonzalez  
Mike LeBarre  
Matthew Simis*

To participate in this Finance Committee meeting through the following methods:

1. You may attend in person,
2. If you wish to comment on a particular agenda item, please submit your comments in writing via email to Monterey County Water Resources Agency at [WRAPubliccomment@co.monterey.ca.us](mailto:WRAPubliccomment@co.monterey.ca.us) by 5:00 p.m. on the Wednesday prior to the Committee meeting. To assist Agency staff in identifying the agenda item to which the comment relates please indicate the Reservoir Operations Advisory Committee meeting date and agenda number in the subject line. Comments received by the 5:00 p.m. Wednesday deadline will be distributed to the Committee and will be placed in the record.
3. If you wish to make either a general public comment for items not on the day's agenda or to comment on a specific agenda item as it is being heard, please submit your comment, limited to 250 words or less, to the Monterey County Water Resources Agency at [WRAPubliccomment@co.monterey.ca.us](mailto:WRAPubliccomment@co.monterey.ca.us). In an effort to assist Agency staff in identifying the agenda item relating to your public comment please indicate in the subject line, the meeting body (i.e. Reservoir Operations Advisory Committee) and item number (i.e. Item No. 10). Every effort will be made to read your comment into the record, but some comments may not be read due to time limitations. Comments received after an agenda item will be made part of the record if received prior to the end of the meeting.
4. If speakers or other members of the public have documents they wish to distribute to the Committee for an agenda item, they are encouraged to submit such documents by 5:00 p.m. on Wednesday before the meeting to: [WRAPubliccomment@co.monterey.ca.us](mailto:WRAPubliccomment@co.monterey.ca.us). To assist Agency staff in identifying the agenda item to which the comment relates, the public is requested to indicate the Reservoir Operations Advisory Committee date and agenda number in the subject line.
5. If members of the public want to present documents/Power Point presentations while speaking, they should submit the document electronically by 5:00 p.m. on Wednesday before the meeting at [WRAPubliccomment@co.monterey.ca.us](mailto:WRAPubliccomment@co.monterey.ca.us). (If submitted after that deadline, staff will make best efforts, but cannot guarantee, to make it available to present during the Committee meeting.)
6. Individuals with disabilities who desire to request a reasonable accommodation or modification to observe or participate in the meeting may make such request by sending an email to [WRAPubliccomment@co.monterey.ca.us](mailto:WRAPubliccomment@co.monterey.ca.us). The request should be made no later than noon on the Wednesday prior to the Committee meeting in order to provide time for the Agency to address the request.
7. The Chair and/or Secretary may set reasonable rules as needed to conduct the meeting in an orderly manner.

Para participar en esta reunión del Comité de Finanzas a través de los siguientes métodos:

1. Podrá asistir personalmente a la reunión; o,
2. Si un miembro del público desea comentar sobre un artículo de la agenda en particular, se le es sumamente recomendable que envíe sus comentarios por escrito por correo electrónico a la Agencia de Administración de Recursos del Agua (Agencia) a [WRAPublicComment@co.monterey.ca.us](mailto:WRAPublicComment@co.monterey.ca.us) antes de las 5:00 P. M. el Miércoles antes de la reunión del Comité. Para ayudar al personal de la Agencia a identificar el número del artículo de la agenda con el cual se relaciona el comentario, se solicita al público que indique la fecha de la reunión del Comité y el número del artículo de la agenda en la línea de asunto. Comentarios recibidos en la fecha límite del Miércoles a las 5 P.M, serán distribuidos al Comité y serán colocados en el registro.
3. Los miembros del público que deseen hacer un comentario público general para temas que no están en la agenda del día o que deseen comentar en un artículo específico mientras se escucha la presentación, lo pueden hacer enviando un comentario por correo electrónico, preferiblemente limitado a 250 palabras o menos, a [WRAPublicComment@co.monterey.ca.us](mailto:WRAPublicComment@co.monterey.ca.us). Para ayudar al personal de la Agencia a identificar el artículo de la agenda con el cual se relaciona el comentario, se solicita al público que indique el nombre del Comité (por ejemplo: Comité Asesor de la Operación de Embalses) y el número del artículo de la agenda (por ejemplo: Artículo # 10). Se hará todo lo posible para leer el comentario en el registro, pero algunos comentarios pueden no leerse en voz alta debido a limitaciones de tiempo. Los comentarios recibidos después del cierre del período de comentarios públicos sobre un artículo de la agenda serán parte del registro si se reciben antes que termine la reunión del Comité.
4. Si los oradores u otros miembros del público tienen documentos que desean distribuir al Comité para un artículo de la agenda, se les recomienda enviar dichos documentos antes de las 5:00 P.M. el Miércoles antes de la reunión a: [WRAPublicComment@co.monterey.ca.us](mailto:WRAPublicComment@co.monterey.ca.us). Para ayudar al personal de la Agencia a identificar el número del artículo de la agenda con el cual se relaciona el comentario, se solicita al público que indique la fecha de la reunión del Comité y el número de agenda en la línea de asunto.
5. Si los miembros del público desean presentar documentos o presentaciones de PowerPoint mientras hablan, deben enviar el documento electrónicamente antes de las 5:00 P.M. del Miércoles antes de la reunión a [WRAPublicComment@co.monterey.ca.us](mailto:WRAPublicComment@co.monterey.ca.us) (Si se presenta después de ese plazo, el personal hará los mejores esfuerzos, pero no puede garantizar que esté disponible su PowerPoint para presentar durante la reunión del Comité).
6. Las personas con discapacidades que deseen solicitar una modificación o modificación razonable para observar o participar en la reunión pueden realizar dicha solicitud enviando un correo electrónico a [WRAPublicComment@co.monterey.ca.us](mailto:WRAPublicComment@co.monterey.ca.us). La solicitud debe hacerse a más tardar el

mediodía del Miércoles antes de a la reunión del Comité para dar tiempo a la Agencia para que atienda la solicitud .

7. El Presidente y / o Secretario pueden establecer reglas razonables según sea necesario para llevar a cabo la reunión de manera ordenada.

Call to

Call to Order

Roll Call

Public Comment

Committee Member Comments

Consent Calendar

1. Approve the minutes of the Finance Committee meeting held on February 2, 2024.

Attachments: [Draft Finance Minutes February 2, 2024](#)

Scheduled Items

2. Consider receiving the January 2024 Financials for All Agency Funds (Staff Presenting; Nora Cervantes)

Attachments: [24\\_01 WRA Financial BFY2023-24\\_R1](#)

3. Consider recommending that the Board of Directors approve an Agreement for Services with Industrial Machine Shop for a new contract for \$250,000 with a contract length of 3 years for: electrical motor repair and rebuilding, well pump and equipment inspection, rebuilding, machining, as well as fabrication services for the Recycle Water Project Facilities; and authorize the General Manager to execute the amendment.

Attachments: [Industrial Machine - RWP agreement Finance Committee March 2024 Board Report](#)

Status Reports

4. Fiscal Year 23-24 Hydroelectric Revenue Summary (Staff Presenting; Nora Cervantes)

Attachments: [FY23 FY24 Hydro Revenue](#)

**Presentations**

5. Preliminary Review - FY2024-25 (Staff Presenting; Nan Kim)

6. What is in Cost Plan. (Staff Presenting; Nan Kim)

**Attachments:** [What is in Cost Plan PPT](#)

### **Information Item**

7. Year-To-Date Expense Report Monterey One Water (Staff Presenting; Nan Kim)

**Attachments:** [M1W YTD expenses thru 2023 12](#)

### **Calendar**

8. Set next meeting date and discuss future agenda items.

### **Adjournment**



WATER RESOURCES AGENCY

MEMORANDUM

---

Monterey County

DATE: February 22, 2024

**PUBLIC MEETING CANCELLATION NOTICE**

**THE BASIN MANAGEMENT ADVISORY  
COMMITTEE MEETING SCHEDULED FOR  
WEDNESDAY MARCH 6, 2024 @ 8:30 AM  
HAS BEEN CANCELLED.**

**THE NEXT MEETING IS SCHEDULED FOR  
WEDNESDAY APRIL 3, 2024 @ 8:30 AM**

**WATER RESOURCES AGENCY  
1441 SCHILLING PLACE  
SALINAS, CA**

# County of Monterey

1441 Schilling Place  
Cinnamon Room  
Salinas, CA 93901



## Meeting Agenda

Wednesday, March 6, 2024

10:00 AM

### Water Resources Agency Planning Committee

*Deidre Sullivan, Chair*  
*Ken Ekelund*  
*Mark Gonzalez*  
*Matthew Simis*

To participate in this Planning Committee meeting through the following methods:

1. You may attend in person,
2. For ZOOM participation please join by computer audio at:  
<https://montereycty.zoom.us/j/95511982423>  
OR to participate by phone call any of these numbers below:  
+1 669 900 6833 US (San Jose)  
+1 346 248 7799 US (Houston)  
+1 312 626 6799 US (Chicago)  
+1 929 205 6099 US (New York)  
+1 253 215 8782 US  
+1 301 715 8592 US

Enter this Meeting ID number: 955 1198 2423, PASSWORD: 884853 when prompted. Please note there is no Participant Code, you will just hit # again after the recording prompts you. You will be placed in the meeting as an attendee; when you are ready to make a public comment, if joined by computer audio, please Raise your Hand; and by phone, please push \*9 on your keypad.

3. If you wish to comment on a specific agenda item while the matter is being heard, you may participate by the following means: When the Chair calls for public comment on an agenda item, the Zoom Meeting Host, or his or her designee, will first ascertain who wants to comment (among those who are in the meeting electronically or telephonically) and will then call on speakers and unmute their device one at a time. Public speakers may be broadcast in audio form only.

**PLEASE NOTE: IF ALL COMMITTEE MEMBERS ARE PRESENT IN PERSON, PUBLIC PARTICIPATION BY ZOOM IS FOR CONVENIENCE ONLY AND IS NOT REQUIRED BY LAW. IF THE ZOOM FEED IS LOST FOR ANY REASON, THE PLANNING COMMITTEE MEETING MAY BE PAUSED WHILE A FIX IS ATTEMPTED BUT THE PLANNING COMMITTEE MEETING MAY CONTINUE AT THE DISCRETION OF THE CHAIRPERSON.**

4. If you wish to comment on a particular agenda item, please submit your comments in writing via email to Monterey County Water Resources Agency at [WRAPubliccomment@co.monterey.ca.us](mailto:WRAPubliccomment@co.monterey.ca.us) by 5:00 p.m. on the Tuesday prior to the Committee meeting. To assist Agency staff in identifying the agenda item to which the comment relates please indicate the Committee meeting date and agenda number in the subject line. Comments received by the 5:00 p.m. Tuesday deadline will be distributed to the Committee and will be placed in the record.

5. If you wish to make either a general public comment for items not on the day's agenda or to Committee Meeting Agenda comment on a specific agenda item as it is being heard, please submit your comment, limited to 250 words or less, to the Monterey County Water Resources Agency at [WRAPubliccomment@co.monterey.ca.us](mailto:WRAPubliccomment@co.monterey.ca.us). In an effort to assist Agency staff in identifying the agenda item relating to your public comment please indicate in the subject line, the meeting body

(i.e. Planning Committee) and item number (i.e. Item No. 10). Every effort will be made to read your comment into the record, but some comments may not be read due to time limitations. Comments received after an agenda item will be made part of the record if received prior to the end of the meeting.

6. If speakers or other members of the public have documents they wish to distribute to the Committee for an agenda item, they are encouraged to submit such documents by 5:00 p.m. on Tuesday before the meeting to: [WRAPubliccomment@co.monterey.ca.us](mailto:WRAPubliccomment@co.monterey.ca.us). To assist Agency staff in identifying the agenda item to which the comment relates, the public is requested to indicate the Committee date and agenda number in the subject line.

7. If members of the public want to present documents/Power Point presentations while speaking, they should submit the document electronically by 5:00 p.m. on Tuesday before the meeting at [WRAPubliccomment@co.monterey.ca.us](mailto:WRAPubliccomment@co.monterey.ca.us). (If submitted after that deadline, staff will make best efforts, but cannot guarantee, to make it available to present during the Committee meeting.)

8. Individuals with disabilities who desire to request a reasonable accommodation or modification to observe or participate in the meeting may make such request by sending an email to [WRAPubliccomment@co.monterey.ca.us](mailto:WRAPubliccomment@co.monterey.ca.us). The request should be made no later than noon on the Wednesday prior to the Committee meeting in order to provide time for the Agency to address the request.

9. The Chair and/or Secretary may set reasonable rules as needed to conduct the meeting in an orderly manner.

Participar en esta reunión del Comité de Planificación a través de los siguientes métodos:

1. Puede asistir en persona,

2.El público puede observar la reunión ZOOM a través de computadora haciendo clic en el siguiente enlace: <https://montereycty.zoom.us/j/95511982423>

O el público puede escuchar a través del teléfono llamando al:

+1 669 900 6833 US (San Jose)

+1 346 248 7799 US (Houston)

+1 312 626 6799 US (Chicago)

+1 929 205 6099 US (New York)

+1 253 215 8782 US

+1 301 715 8592 US

Cuando se le solicite el código de acceso para entrar a la reunión, presione los siguientes números: 955 1198 2423, PASSWORD: 884853 . Tenga en cuenta que no hay un Código de participante, simplemente presionará # nuevamente después de que la grabación lo solicite.

Se le colocará en la reunión como asistente; cuando esté listo para hacer un comentario público si se une al audio de la computadora, levante la mano; y por teléfono presione \* 9 en su teclado.

3. Los miembros del público que desean comentar en un artículo específico de la agenda, mientras que el artículo se este presentando durante la reunión, pueden participar por cualquiera de los siguientes medios: Cuando el Presidente del Comité solicite comentarios públicos sobre un artículo de la agenda, el anfitrión de la reunión Zoom o su designado, primero determinará quién quiere testificar (entre los que están en la reunión por vía electrónica o telefónica) y luego llamará a los oradores (speakers) y activará la bocina para el orador, uno a la vez. Todo orador, será transmitido por audio en altavoz solamente.

**TENGA EN CUENTA: SI TODOS LOS MIEMBROS DEL COMITÉ ESTÁN PRESENTES EN PERSONA, LA PARTICIPACIÓN PÚBLICA DE ZOOM ES SOLO POR CONVENIENCIA Y NO ES REQUERIDA POR LA LEY. SI LA FUENTE DE ZOOM SE PIERDE POR CUALQUIER MOTIVO, LA REUNIÓN DEL COMITÉ DE PLANIFICACIÓN PUEDE PAUSARSE MIENTRAS SE INTENTA UNA SOLUCIÓN, PERO LA REUNIÓN DEL COMITÉ DE PLANIFICACIÓN PUEDE CONTINUAR A DISCRECIÓN DEL PRESIDENTE.**

4. Si un miembro del público desea comentar sobre un artículo de la agenda en particular, se le es sumamente recomendable que envíe sus comentarios por escrito por correo electrónico a la Agencia de Administración de Recursos del Agua (Agencia) a [WRAPubliccomment@co.monterey.ca.us](mailto:WRAPubliccomment@co.monterey.ca.us) antes de las 5:00 P. M. el Martes antes de la reunión del Comité. Para ayudar al personal de la Agencia a identificar el número del artículo de la agenda con el cual se relaciona el comentario, se solicita al público que indique la fecha de la reunión del Comité y el número del artículo de la agenda en la línea de asunto. Comentarios recibidos en la fecha límite del Martes a las 5 P.M, serán distribuidos al Comité y serán colocados en el registro.

5. Los miembros del público que deseen hacer un comentario público general para temas que no están en la agenda del día o que deseen comentar en un artículo específico mientras se escucha la presentación, lo pueden hacer enviando un comentario por correo electrónico, preferiblemente limitado a 250 palabras o menos, a [WRAPubliccomment@co.monterey.ca.us](mailto:WRAPubliccomment@co.monterey.ca.us). Para ayudar al personal de la Agencia a identificar el artículo de la agenda con el cual se relaciona el comentario, se solicita al público que indique el nombre del Comité (por ejemplo: Comité de Planificación) y el número del artículo de la agenda (por ejemplo: Artículo # 10). Se hará todo lo posible para leer el comentario en el registro, pero algunos comentarios pueden no leerse en voz alta debido a limitaciones de tiempo. Los comentarios recibidos después del cierre del período de comentarios públicos sobre un artículo de la agenda serán parte del registro si se reciben antes que termine la reunión del Comité.

6. Si los oradores u otros miembros del público tienen documentos que desean distribuir al Comité para un artículo de la agenda, se les recomienda enviar dichos documentos antes de las 5:00 P.M. el Martes antes de la reunión a: [WRAPubliccomment@co.monterey.ca.us](mailto:WRAPubliccomment@co.monterey.ca.us). Para ayudar al personal de

la Agencia a identificar el número del artículo de la agenda con el cual se relaciona el comentario, se solicita al público que indique la fecha de la reunión del Comité y el número de agenda en la línea de asunto.

7. Si los miembros del público desean presentar documentos o presentaciones de PowerPoint mientras hablan, deben enviar el documento electrónicamente antes de las 5:00 P.M. del Martes antes de la reunión a [WRAPublicComment@co.monterey.ca.us](mailto:WRAPublicComment@co.monterey.ca.us) (Si se presenta después de ese plazo, el personal hará los mejores esfuerzos, pero no puede garantizar que esté disponible su PowerPoint para presentar durante la reunión del Comité).

8. Las personas con discapacidades que deseen solicitar una modificación o modificación razonable para observar o participar en la reunión pueden realizar dicha solicitud enviando un correo electrónico a [WRAPublicComment@co.monterey.ca.us](mailto:WRAPublicComment@co.monterey.ca.us). La solicitud debe hacerse a más tardar el mediodía del Martes antes de la reunión del Comité para dar tiempo a la Agencia para que atienda la solicitud.

9. El Presidente y / o Secretario pueden establecer reglas razonables según sea necesario para llevar a cabo la reunión de manera ordenada.

#### Call to Order

#### Roll Call

#### Public Comment

#### Committee Member Comments

#### Consent Calendar

1. Approve the Action Minutes of the Planning Committee meeting held on February 7, 2024.

**Attachments:** [Draft Planning Minutes February 7, 2024](#)

#### Staff Reports

2. Overview of the Strategic Planning Workshop Report. (Staff Presenting; Shaunna Murray)

**Attachments:** [MCWRA\\_BoardStratPlanWorkshop2024\\_FinalReport](#)

3. Review Staff Survey questions and procedures. (Staff Presenting; Shaunna Murray)

#### Calendar

4. Set next meeting date and discuss future agenda items.

**Adjournment**



# County of Monterey

**Item No.12**

## Board Report

Board of Supervisors  
Chambers  
168 W. Alisal St., 1st Floor  
Salinas, CA 93901

**Legistar File Number: WRAG 24-040**

**March 18, 2024**

**Introduced:** 3/12/2024

**Current Status:** Draft

**Version:** 1

**Matter Type:** WR General Agenda

Reservoir Storage and Release Update. (Staff: Joseph Klein, Peter Kwiek)

## Reservoir Storage & Release Update

### SUMMARY/DISCUSSION:

The Board of Directors receives monthly updates on the status of Agency reservoirs.

**RESERVOIR ELEVATION / STORAGE:** As of March 11, 2024, San Antonio Reservoir has a water surface elevation of approximately 765.55 feet (NGVD 29), with 260,908 acre-feet of water in storage. Nacimiento Reservoir has a water surface elevation of approximately 794.7 feet, with 348,230 acre-feet of water in storage. San Antonio Reservoir is currently at 78% of storage capacity and Nacimiento Reservoir is at 92% of capacity.

**RESERVOIR RELEASES:** Following a staff assessment of watershed conditions in response to hydrologic triggers, Nacimiento releases were increased on February 1, 2024, to an approximate flowrate range of 280 to 300 cfs, to support Steelhead passage conditions, in accordance with the Agency's Interim Operations Plan and the Salinas Valley Water Project Flow Prescription for Steelhead Trout in the Salinas River. By February 3, sustained storm activity had begun to provide targeted Flow Prescription flowrates in the lower Salinas River, obviating the need for supplemental flow, and Nacimiento releases were reduced to minimum fisheries releases of 60 cfs. Subsequently, on February 5, periodic inspection and testing of Nacimiento's high level gates required a temporary release of water through the gates, resulting in a daily average flowrate of approximately 90 cfs on that day. Nacimiento releases were subsequently reduced to a target flow of 60 cfs to support fish habitat below the dams. On February 18, during the storms occurring over the Presidents Day weekend, an outage of the Nacimiento hydropower plant resulted in a shift in releases to a combination of valves and bypass flow requiring a slight increase in releases (to about 80 cfs) to avoid valve cavitation. Region-wide storm activity in late February and early March necessitated the initiation of flood control releases of approximately 1,000 cfs from Nacimiento Reservoir on March 2, to maintain sufficient empty space to accommodate additional inflow. As of March 8, flood control releases have been reduced to approximately 350 cfs, as inflow has tapered off. San Antonio Reservoir has remained at minimum fisheries releases of 10 cfs since the end of conservation releases on October 27, 2023.

**INFLOW:** Rainfall through the region this winter has generated inflow to both reservoirs. Since December 18, storage volume at Nacimiento reservoir has increased by approximately 140,400 acre-feet and storage volume at San Antonio Reservoir has increased by approximately 46,500 acre-feet.

**SALINAS LAGOON:** High tides and large waves on December 28 and 30, 2023 caused the Salinas Lagoon to fill to over 7 feet in elevation. Agency staff managed the sandbar to open the lagoon to the ocean on January 4, 2024. The lagoon has remained open to the ocean since this action.

Releases as of March 11, 2024:

- Nacimiento Reservoir: 340 cfs
- San Antonio Reservoir: 10 cfs

Total releases from both reservoirs to the Salinas River are approximately 350 cfs. The following "provisional" flows have been recorded by the USGS:

- Salinas River near Bradley: 819 cfs
- Salinas River at Soledad: 884 cfs
- Salinas River near Chualar: 1,400 cfs
- Salinas River near Spreckels: 932 cfs

Prepared by: Joseph Klein, Water Resources Hydrologist (831) 755-4860  
Peter Kwiek, Associate Hydrologist (831) 755-4860



***Before the Board of Directors of the Monterey County Water Resources Agency  
County of Monterey, State of California***

BOARD ORDER No. 24-008

**APPROVE AN INTELLECTUAL PROPERTY RIGHTS TRANSFER )  
AGREEMENT WITH THE GROWER-SHIPPER ASSOCIATION )  
OF CENTRAL CALIFORNIA, INC. FOR AN UPDATED FLOOD )  
MODEL OF THE SALINAS RIVER, AND AUTHORIZE THE )  
GENERAL MANAGER TO EXECUTE THE AGREEMENT. )**

Upon motion of Director John Baillie, seconded by Director Mark Gonzalez, and carried by those members present, the Board of Directors hereby:

1. Approves an Intellectual Property Rights Transfer Agreement with the Grower-Shipper Association of Central California, Inc. for an updated flood model of the Salinas River.
2. Authorizes the General Manager to execute the Agreement.

PASSED AND ADOPTED on this **18th** day of **March 2024**, by the following vote, to-wit:

AYES: Mike LeBarre, Matt Simis, Mark Gonzalez, Deidre Sullivan, Mike Scattini, John Baillie, Marvin Borzini

NOES: None

ABSENT: Ken Ekelund, Jason Smith

DocuSigned by:  
*Mike LeBarre*  
3DE98E68D10E4DB  
BY: Mike LeBarre, Chair  
Board of Directors

DocuSigned by:  
*Ara Azhderian*  
1E182FFB49A2435  
ATTEST: Ara Azhderian  
General Manager



***Before the Board of Directors of the Monterey County Water Resources Agency***  
***County of Monterey, State of California***

BOARD ORDER No. 24-007

RECOMMEND THAT THE MONTEREY COUNTY WATER RESOURCES )  
BOARD OF SUPERVISORS APPROVE AND AUTHORIZE THE GENERAL )  
MANAGER OF THE MONTEREY COUNTY WATER RESOURCES )  
AGENCY TO ACCEPT A DONATION OF FUNDING FOR CHAIN LINK )  
FENCING VALUED AT \$4,500.00 FROM CYPRESS CREEK APARTMENTS )

Upon motion of Director John Baillie, seconded by Director Mark Gonzalez, and carried by those members present, the Board of Directors hereby:

Recommend that the Monterey County Water Resources Agency Board of Supervisors approve and authorize the General Manager of the Monterey County Water Resources Agency to accept a donation of funding for chain link fencing valued at \$4,500.00 from Cypress Creek Apartments.

PASSED AND ADOPTED on this **18th** of **March 2024**, by the following vote, to-wit:

AYES: Mike LeBarre, Matt Simis, Mark Gonzalez, Deidre Sullivan, Mike Scattini, John Baillie, Marvin Borzini

NOES: None

ABSENT: Ken Ekelund, Jason Smith

DocuSigned by:  
*Mike LeBarre*  
3DE98F68D10F4DB...

BY: Mike LeBarre, Chair  
Board of Directors

DocuSigned by:  
*Ara Azhderian*  
1F182FFB49A2435

ATTEST: Ara Azhderian  
General Manager



***Before the Board of Directors of the Monterey County Water Resources Agency  
County of Monterey, State of California***

BOARD ORDER No. 24-006

**Approve an Agreement for Services with Industrial Machine Shop with a contract term to June 30, 2027, and an amount not to exceed \$250,000 for electrical motor repair and rebuilding, well pump and equipment inspection, rebuilding, machining, as well as fabrication services for the Recycle Water Project Facilities; and authorize the General Manager to execute the agreement.**

Upon motion of Director John Baillie, seconded by Director Mark Gonzalez, and carried by those members present, the Board of Directors hereby:

Approve an Agreement for Services with Industrial Machine Shop with a contract term to June 30, 2027, and an amount not to exceed \$250,000 for electrical motor repair and rebuilding, well pump and equipment inspection, rebuilding, machining, as well as fabrication services for the Recycle Water Project Facilities; and authorize the General Manager to execute the agreement.

PASSED AND ADOPTED on this **18th** day of **March 2024**, by the following vote, to-wit:

AYES: Mike LeBarre, Matt Simis, Mark Gonzalez, Deidre Sullivan, Mike Scattini, John Baillie, Marvin Borzini

NOES: None

ABSENT: Ken Ekelund, Jason Smith

DocuSigned by:  
*Mike LeBarre*  
3DE98F68D10F4DB...  
BY: Mike LeBarre, Chair  
Board of Directors

DocuSigned by:  
*Ara Azhderian*  
1E182EEB49A2435  
ATTEST: Ara Azhderian  
General Manager



***Before the Board of Directors of the Monterey County Water Resources Agency  
County of Monterey, State of California***

BOARD ORDER No. 24-005

**APPROVE AMENDMENT NO. 2 OF THE AGREEMENT FOR )  
PROFESSIONAL SERVICES WITH GEI CONSULTANTS, INC, IN )  
THE AMOUNT OF \$70,000 FOR ENGINEERING DESIGN & )  
PROJECT MANAGEMENT SERVICES FOR STORM DAMAGE )  
REPAIR DESIGN AND IMPLEMENTATION OF THE NACIMIENTO )  
DAM HYDRO-PLANT’S SOUTH ACCESS ROAD; AND AUTHORIZE )  
THE GENERAL MANAGER TO EXECUTE THE AMENDMENT. )**

Upon motion of Director John Baillie, seconded by Director Mark Gonzalez, and carried by those members present, the Board of Directors hereby:

1. Approve Amendment No. 2 of the Agreement for Professional Services with GEI Consultants, Inc, in the amount of \$70,000 for engineering design & project management services for storm damage repair design and implementation of the Nacimiento Dam Hydro-plant’s South Access Road; and
2. Authorizes the General Manager to execute the amendment.

PASSED AND ADOPTED on this **18th** day of **March 2024**, by the following vote, to-wit:

AYES: Mike LeBarre, Matt Simis, Mark Gonzalez, Deidre Sullivan, Mike Scattini, John Baillie, Marvin Borzini

NOES: None

ABSENT: Ken Ekelund, Jason Smith

DocuSigned by:  
*Mike LeBarre*  
3DE98F68D10F4DB...

BY: Mike LeBarre, Chair  
Board of Directors

DocuSigned by:  
*Ara Azhderian*  
1E182FFB48A243E...

ATTEST: Ara Azhderian  
General Manager