

Attachment E

This page intentionally left blank.



NOTICE OF APPEAL

Monterey County Code
 Title 19 (Subdivisions)
 Title 20 (Zoning)
 Title 21 (Zoning)

RECEIVED
 MONTEREY COUNTY

MAR 23 2023

CLERK OF THE BOARD

DEPUTY

VICENTE RAMIREZ

No appeal will be accepted until written notice of the decision has been given. If you wish to file an appeal, you must do so on or before _____ (10 days after written notice of the decision has been mailed to the applicant).

Date of decision: March 8, 2023

1. Appellant Name: Caltrans District 5, Attn: Mitch Dallas
 Address: 2885 S. Higuera Street, San Luis Obispo, CA 93401
 Telephone: (805) 748-7004

2. Indicate your interest in the decision by placing a check mark below:

Applicant _____

Neighbor _____

Other (please state) _____

3. If you are not the applicant, please give the applicant's name:

4. Fill in the file number of the application that is the subject of this appeal below:

	Type of Application	Area
a)	Planning Commission: PC- <u>PLN220090</u>	<u>Big Sur Coastal Area</u>
b)	Zoning Administrator: ZA- _____	_____
c)	Administrative Permit: AP- _____	_____

Notice of Appeal

5. What is the nature of your appeal?

a) Are you appealing the approval or denial of an application? Denial

b) If you are appealing one or more conditions of approval, list the condition number and state the condition(s) you are appealing. (Attach extra sheet if necessary)
No _____

6. Place a check mark beside the reason(s) for your appeal:

There was a lack of fair or impartial hearing _____
The findings or decision or conditions are not supported by the evidence X
The decision was contrary to law X

7. Give a brief and specific statement in support of each of the reasons for your appeal checked above. The Board of Supervisors will not accept an application for an appeal that is stated in generalities, legal or otherwise. If you are appealing specific conditions, you must list the number of each condition and the basis for your appeal. (Attach extra sheets if necessary)

Please see attached letter.

8. As part of the application approval or denial process, findings were made by the decision-making body (Planning Commission, Zoning Administrator, or Chief of Planning). In order to file a valid appeal, you must give specific reasons why you disagree with the findings made. (Attach extra sheets if necessary)

Please see attached letter.

9. You must pay the required filing fee of \$3,572.00 (make check payable to "County of Monterey") at the time you file your appeal. (Please note that appeals of projects in the Coastal Zone are not subject to the filing fee.)

10. Your appeal is accepted when the Clerk to the Board accepts the appeal as complete and receives the required filing fee. Once the appeal has been accepted, the Clerk to the Board will set a date for the public hearing on the appeal before the Board of Supervisors.

The appeal and applicable filing fee must be delivered to the Clerk to the Board or mailed and postmarked by the filing deadline to PO Box 1728, Salinas CA 93902. A facsimile copy of the appeal will be accepted only if the hard copy of the appeal and applicable filing fee are mailed and postmarked by the deadline.

APPELLANT SIGNATURE MC DSK Date: 3/20/23

RECEIVED SIGNATURE [Signature] Date: 3/23/23

California Department of Transportation

CALTRANS DISTRICT 5
50 HIGUERA STREET | SAN LUIS OBISPO, CA 93401-5415
(805) 549-3101 | FAX (805) 549-3329 TTY 711
www.dot.ca.gov



March 21, 2023

Clerk of the Board of Supervisors
Monterey County
PO Box 1728
Salinas, California 93902

Subject: Appeal of Planning Commission Denial of Caltrans Garrapata Creek Bridge Railing Replacement Project PLN220090 (Item No. 3) on March 8, 2023

Reference: EA 05-1H800/Project ID 0516000163/SCH No. 2020049027

Dear Madame Clerk of the Board:

The California Department of Transportation (Caltrans) is the applicant for a Combined Development Permit for the Garrapata Creek Railing Replacement Project (PLN220090) and wishes to appeal the Planning Commission's denial of the project during its meeting on March 8, 2023. Our appeal application form is contained as Enclosure 1 of this letter and the Planning Commission's Resolution for Denial is contained as Enclosure 2 of this letter.

As part of this appeal documentation, we incorporate by reference Monterey County Housing & Community Development Department's staff report to the Planning Commission for their February 22, 2023 hearing on the project, where staff recommended approval of the project. In addition, we incorporate by reference the large volume of information provided by Caltrans on the project in the application submittal package, as well as letters submitted to Monterey County staff on August 15, 2022 and on December 6, 2022 in response to staff comments (Exhibits H and F of the Planning Commission's February 22, 2023 staff report).

As described in more detail below, Caltrans wishes to appeal the Planning Commission's March 8, 2023 denial of the project both (1) because the decision and findings are not supported by accurate evidence and (2) because the decision was contrary to law.

Decision Not Supported by Evidence

Finding 2

Finding 2 stating project inconsistency with the Monterey County Local Coastal Program is not supported by accurate evidence as discussed below.

“Evidence” 2.a. (Past Communications) is Vague. It is stated “Communications were received during the course of review of the project indicating inconsistencies with the text, policies, and regulations of these documents...” However, the nature and extent of these “communications” are not disclosed.

“Evidence” 2.f. (Visual Access) is Not Accurate. The County’s statement that the project is inconsistent with LUP Public Access Key Policy 6.1.3 is not accurate. The policy indicates that “visual access should be protected for long term public use.” According to the Big Sur Coastal Implementation Plan, “visual access” is defined as “access for scenic viewing of the shoreline and/or ocean from either a vista point or public road or trail. (Monterey County Planning Department).” We understand that “visual access” was intended to have a much broader context and understand the sensitivity and global significance of the driver’s experience while traveling along State Route 1 along the Big Sur Coast and the ability of the driver and passengers to see through the open balustrade railings of Big Sur’s historic bridges as part of that experience.

With the new proposed open balustrade design on the Garrapata Creek Bridge, the public, residents, and workers in the area will continue to enjoy that driver experience, with continued views of the vegetation and beach through the clear openings of the rails and expansive views of the ocean over the top of the rail, both of which comprise the landscape that is viewed as one travels across the bridge. The visual simulations presented to the public in the EIR and during the permitting process included in Enclosure 3 (and also included in Exhibit B of the March 8, 2023 Planning Commission Staff Report), serve as substantial evidence that Caltrans used in making its conclusions regarding project-specific impacts on visual resources. According to the visual simulations, views of the vegetation and beach through the clear openings are still present under the proposed project.

In addition, visual access to the Big Sur coast cannot be accomplished without adequate safe physical access to these areas. The proposed project would ensure adequate safe physical access across the bridge, and therefore, continue to enable visual access to the Big Sur coast.

Therefore, because the proposed project would still continue to provide views of the vegetation and beach through the clear openings of the rails and expansive views of the ocean over the top of the rail as well as safe physical access to the Big Sur coast, the proposed project would be consistent with LUP Public Access Key Policy 6.1.3 and other public access protection policies discussed below.

“Evidence” 2.g. (Views of the Ocean) is Not Accurate. This paragraph states that the smaller openings, thicker bottom rail, and added strong posts would adversely impact public views, as the existing larger openings frame views outward of the ocean and dramatic coast line.” As evidenced by the visual simulations in the plan set for the project (see Exhibit B of the March 8, 2023 staff report), there are no views of the ocean through the clear openings between the balusters of the existing railing. There are views of upland vegetated slopes and the beach through the clear openings. Motorists would be traveling at 55 miles per hour across on the bridge, and would continue to have blurred views of the entire landscape, through the clear openings of the proposed new balusters and expansive views of the ocean over the top of the railing. Cyclists and pedestrians would also continue to be able to enjoy views of the landscape through the clear openings.

Finally, to address the last sentence of this finding regarding cumulative impacts, Caltrans conducted a thorough cumulative impact analysis for the proposed project which is contained in the EIR. Visual impacts will be analyzed for each individual future bridge proposed for railing replacement through independent environmental review and permitting, and each railing design will be customized to match the existing design to the maximum extent

“Evidence” 2.h. (Alternatives Analysis) is Not Accurate. The statement that Caltrans “has not demonstrated that other design options have been given adequate consideration. Options for repair, speed reductions, bridge rail openings, and relief from typical crash test rating standards are discussed in the evidence that follow” is not true. Caltrans has given extensive and exhaustive consideration of all of the options raised by the County and the public, including options for repair, speed reductions, bridge rail openings, and relief from typical crash test rating standards, as well as other options, during the following steps of project development:

- Caltrans' bridge inspection processes;
- CEQA/NEPA review of the project;
- Caltrans' project programming processes; and
- Caltrans' project design processes, including implementation of a speed survey, crash testing and structural analysis of the design.

These considerations have all been presented to County staff, decision-makers and the public throughout the CEQA/NEPA and permit processes.

Since their original construction, the Garrapata Creek Bridge rails have experienced “gross deterioration” as described and shown in Photos 4, 5, 6, and 7 of Caltrans

Structure Maintenance & Investigations' Bridge Inspections Report dated September 25, 2009, contained in Enclosure 4 of this letter, and previously provided to County staff and the Planning Commission in Exhibit F of the Planning Commission's February 22, 2023 staff report.

Replacement of the bridge railing is required as a result of its deteriorated state. The bridge rail replacement must meet crash testing requirements as outlined in the American Association of Highway and Transportation Officials (AASHTO) Manual for Assessing Safety Hardware (MASH) guidelines as discussed below.

"Evidence" 2.i. (Repair) is Not Accurate. In "Evidence" 2.i., it is insinuated that there still may be some option to repair the rail if speed/traffic is altered or under some other unstated circumstance. In Caltrans' letter submitted to the County on December 6, 2022 (see Exhibit F of the Planning Commission's February 22, 2023 staff report on the project), it is clearly stated by District 5 Maintenance and Caltrans' Headquarters Structures Maintenance & Investigations (SM&I) that "replacement of the railing is the only repair strategy." This information is stated in the EIR for the project, application materials, and a letter submitted in on August 15, 2022 as well.

"Evidence" 2.j. (Speed Reduction) is Not Accurate and Speculative. "Evidence" 2.j. states that "it is unclear if options for reduced speed zone and other traffic calming or control devices to induce lower speeds have been sufficiently explored in this case." The test level in the Manual for Assessing Safety Hardware (MASH) (page 5, Second Edition, 2016) is defined by "impact conditions" and therefore is set by the current "operating speed," not posted speed limits or hypothetical speeds that may be accomplished in the future. It is also speculative to assume that hypothetical traffic calming measures could be designed, approved by the County, and/or would be effective at reducing speeds below 45 miles per hour.

In addition, "Evidence" 2.j. states "...a 'TR-2' [Test Level TL-2] rail, as opposed to the proposed 'TR-4' [Test Level TL-4] rail, which could have taller (but not wider) openings, closer to the aesthetic of the original rails." No evidence is provided to justify how a TL-2 rail design would better approximate the original rails and significantly reduce visual impacts. It is speculative to assume that a TL-2 rail design could be approved that would better approximate the original rails, and significantly reduce impacts on visual resources. For example, the existing approved TL-2 rail design that "best approximates" the existing bridge railing according to a comment received by a member of the Historic Resources Review Board, is Texas Department of Transportation's C411 bridge railing. Standard Plans for this railing type are shown in Enclosure 5. According to the standard plans for the C411, it is true that the arch windows can be up to 24 inches high where existing arch windows on the Garrapata Creek Bridge are 20 inches high and arch windows under the Type 86H would be

15.125 inches high at the traffic face. However, clear openings in C411 would still be restricted to 6 inches and baluster lengths (parallel to traffic) in the C411 are 10 inches as opposed to 6 inches under the existing railing and proposed Type 86H railing. Therefore, although arch windows could be higher with a C411 design, the baluster lengths would be 4-inches larger each, thus resulting in a similar, if not greater, magnitude of impact on views from the bridge deck as the Type 86H.

Caltrans has custom-designed the Type 86H rail as a new MASH-compliant railing that is context-sensitive and compatible with the historic character of the Garrapata Creek Bridge and the Carmel San Simeon Highway Historic District (CSSHHD), and therefore, the visual character of the area. Caltrans' Structures Design Engineers developed the new bridge rail design specifically to replicate the design of the historic rails as closely as possible while also meeting the new MASH crashworthiness standards under current roadway conditions (the new Caltrans rail design Type 86H). This will enable expedient replacement of this important traffic safety system on the Garrapata Creek Bridge.

“Evidence” 2.k. (Width of Opening) is Not Accurate and Misleading. The statement “In the EIR, the identified purpose of the narrower opening is to prevent catch points, which can hook cars bumpers and increase the severity of accidents. The health and safety need for the features creating additional obstruction to the viewshed should be clarified and confirmed,” is not accurate and is misleading. The health and safety need for the design specifications of the proposed bridge railing have been clearly and repeatedly stated throughout the CEQA/NEPA processes and permitting process. It is Caltrans' primary mandate to ensure public health and safety through its design specifications on State Highway Systems. Bridge railing is a critical traffic safety system of bridges. The Garrapata Creek Bridge railing is called a combination rail because it is required to be protective of bicyclists and pedestrians as well as motorists. The design of the proposed new bridge railing for the Garrapata Creek Bridge was developed following three manuals: (1) the AASHTO Load and Resistance Factor Design (LRFD) Bridge Design Specifications, Eighth Edition with California Amendments (AASHTO-CA BDS-8), (3) Caltrans' Traffic Safety Systems Guidance, and (2) the Manual for Assessing Safety Hardware (MASH). AASHTO-CA BDS-8 constitutes the primary design specifications for California bridges and transportation-related structures; adoption of AASHTO-CA BDS-8 is mandatory for all projects on or after November 1, 2019. Regarding bridge railings, the AASHTO-CA BDS-8 contains height requirements as well as requirements for clear openings to protect bicyclists, pedestrians, as well as motorcyclists. AASHTO-CA BDS-8 requires that bridge railings be no less than 42 inches high and requires that clear openings are not greater than 6-inches in the lower 27-inches of the railing (Sections 13.8.1 and 13.9.1).

Further, because bridge railings are a traffic safety system, the design of bridge rail must adhere to the Manual for Assessing Safety Hardware (MASH) based on:

1. The Implementation of the Manual for Assessing Safety Hardware dated December 23, 2016; and
2. The Interim Type Selection Guidelines for Bridge Railings in California dated August 2, 2019.

The bridge rail policy memos mentioned above (and included in Enclosure 8) do not provide any exception process to a bridge rail to not meet MASH requirements. Furthermore, the bridge rail design policy memo does not provide an exception to the appropriate crash testing test-level. Additionally, the Traffic Safety Systems Guidance states, "only Caltrans approved MASH safety systems will be allowed on California State Highways" (page 8).

Finally, the Manual for Assessing Safety Hardware presents uniform crash testing guidelines that establish a minimum set of requirements that a roadside safety feature must meet in order to demonstrate its satisfactory impact performance and vehicle redirection back towards the roadway. Performance is evaluated in terms of the risk of injury to occupants of the impacting vehicle, the structural adequacy of the safety feature, the exposure to workers and pedestrians that may be behind a barrier or in the path of debris resulting from impact with a safety feature, and the post-impact behavior of the test vehicle. As stated in the MASH Guidelines, in addition to full-scale crash testing to demonstrate the satisfactory impact performance of the feature, "during the early stages of design and development, analytical and experimental tools are typically used to aid in the process including: principles of mechanics, static tests, dynamic tests, and computer simulation" and "the initial design is typically developed using structural loading and design procedures based on the principles of mechanics." The Type 86H bridge railing for the Garrapata Creek Bridge was designed following these manuals and methodologies, as well as based upon successful crash testing, computer simulation, and supporting structural strength analysis to maximize the protection of public health and safety.

Failure to follow the MASH Guidelines and Caltrans bridge rail design guidelines implies that death and serious injury is acceptable. Caltrans Director's Policy DP-36 states that death and serious injury is unacceptable. As such:

1. There is no exception to safety requirements found in the Caltrans bridge rail and MASH implementation policies.
2. A Test Level-4 bridge rail is acceptable and appropriate for Caltrans' proposed Garrapata Creek Bridge rail.

“Evidence” 2.I. (Design Exceptions) is Not Accurate. See response to “Evidence” 2.k. above. In addition, the statement that “the potential for an exception to these rules should be taken to the highest possible approval body” is not true and misleading. The potential for an exception has already been considered by the Caltrans personnel with the responsibility and authority to do so, which has been stated repeatedly.

The State Bridge Engineer is responsible for approving any exceptions to adopting provisions in the AASHTO-CA BDS-8 (see Enclosure 6). The top authority in the State of California, the State Bridge Engineer and Chief of the Division of Engineering Services has addressed this specifically in the attached letter (see Enclosure 7).

Furthermore, Caltrans has custom-designed a new MASH-compliant railing that is context-sensitive and compatible with the historic character of the Garrapata Creek Bridge and the Carmel San Simeon Highway Historic District (CSSHHD), and therefore, the visual character of the area. Caltrans' Structures Design Engineers developed a new bridge rail that is designed specifically to replicate the design of the historic rails as closely as possible while also meeting the new MASH crashworthiness standards (the new Caltrans rail design Type 86H). In addition, Caltrans will be creating an interpretive website of the historic Big Sur bridges as a cultural resources mitigation measure outlined in the Memorandum of Agreement between Caltrans and the State Historic Preservation Officer (SHPO), which will also help offset impacts on visual resources as follows:

- Caltrans District 5 will produce a website highlighting the history of the seven Big Sur Arches in a manner that is accessible to the general public and provides public benefit.
- The website will initially contain a main page focusing on the general history of the seven bridges included in the Tier 1 analysis, as well as at least one page focusing on the Garrapata Creek Bridge individually. The website will also include pages to host the historic and modern photographs, the historic context as developed, the lesson plans, and additional information on the engineering and transportation history of the bridges as is deemed appropriate through future studies. The website will be structured so that it may be updated and expanded with additional pages that focus on the Big Sur Arches impacted through the future bridge rail replacement projects outlined in the current Tier 1 analysis or any other projects impacting the Big Sur Arches.

Finding 3

The following statement in Finding 3 regarding Health and Safety is not true and is not supported by evidence:

"Denial of the Project applied for will not under the circumstances of this particular case be detrimental to the health, safety, peace, morals, comfort, and general welfare of persons residing or working in the neighborhood of such proposed use, or be detrimental or injurious to property and improvements in the neighborhood or to the general welfare of the County."

Specifically, as supported above under the discussion of Finding 2, denial of the project would hinder Caltrans' ability to ensure public safety on the Garrapata Creek Bridge resulting in delay of implementation of the project and exacerbating risk to public safety traveling across the Garrapata Creek Bridge. This would impact millions of visitors to the area and hundreds of persons residing or working in the neighborhood of the Garrapata Creek Bridge. Denial of the project would be detrimental to the safety and general welfare of the public and persons residing and working in the neighborhood of the project.

The County's "evidence" cited for their Finding No. 3, is not accurate. Specifically, the statement that the bridge rails "have remained in their current configuration" is not true. Since their original construction, the bridge rails have experienced "gross deterioration" as described and shown in Photos 4, 5, 6, and 7 of Caltrans Structure Maintenance & Investigations' Bridge Inspections Report dated September 25, 2009, contained in Enclosure 4 of this letter, and previously provided to County staff and the Planning Commission in Exhibit F of the Planning Commission's February 22, 2023 staff report.

The County's statement that "Despite the lack of past incidents, temporary measures may be needed to secure the bridge rails for current and future travelers until a permanent solution is provided" is not true and not backed by evidence. A permanent solution to secure the current and future travelers is needed now. The September 25, 2009 Bridge Inspection Report concludes (pages 1 and 2):

"The rail end posts are covered with fine pattern cracking. See the attached photo. The barrier rail posts are highly deteriorated, with dozens of incipient spalls and five fully spalled posts. No work was recommended since there was an existing STRAIN recommendation for a rail upgrade (Fiscal Year 2001). However, the railing needs replacement. An email was sent to Roger Hunter 2/24/11 requesting the rail replacement be expedited."

In our application materials, and letter sent to the County dated December 6, 2022 included as Exhibit F of the Planning Commission's February 22, 2023 staff report, Caltrans has repeatedly stated that the railing is "damaged beyond repair," the railing is "deemed not to be crash-worthy at any speed," and must be replaced now.

Decision Was Contrary to Law

Denial of the Project is in Conflict with State Law

Caltrans is a department of the California State Transportation Agency and has full possession and control of all state highways and all property and rights acquired for state highway purposes (Section 90, California Streets and Highways Code). Caltrans is authorized and directed to lay out and construct all state highways (Section 90, California Streets and Highways Code) and shall improve and maintain the state highways as provided in the California Streets and Highways Code (Section 91, California Streets and Highways Code). "Caltrans may do any act necessary, convenient or proper for the construction, improvement, maintenance or use of all highways which are under its jurisdiction, possession or control" (Section 92, California Streets and Highways Code). "Caltrans may restrict the use of, or close, any State highway whenever the department considers such closing or restriction of use necessary (Section 124, Streets and Highways Code):

- (a) For the protection of the public.
- (b) For the protection of such highway from damage during storms or during construction, improvement or maintenance operations thereon."

Public comment has insinuated that Caltrans is able to "replicate" the existing bridge railing design if a design exception can be made by Caltrans and/or if the speed limit could be reduced on State Route 1 to 45 mph or less. In fact, under all circumstances, Caltrans is unable to replicate the existing rail. This statement has been made repeatedly and in numerous documents including the CEQA document for the project and in documentation under Caltrans' Section 106 consultation with the SHPO. Specifically, the current required MASH standard and AASHTO-CA BDS-8 standards for bridge railing at any speed requires the use of 6-inch clear openings between balusters, whereas the existing clear openings are 10 inches. In addition, the base of the railing must be larger than the existing railing under current standards. The current standards were developed at the national level by the Federal Highway Administration (FHWA) and by the American Association of Highway and Transportation Officials (AASHTO) and adopted by the State of California. AASHTO is a standards-setting body which publishes specifications, test protocols and guidelines that are used in highway design and construction throughout the United States. The design specifications required to meet these standards were established to prevent or

March 21, 2023

Page 10

minimize the loss of life and property by the public traveling along State Route 1. Specifically, current standards require that clear openings between balusters shall not exceed 6 inches in the lower 27-inches of the railing to minimize the potential for the clear openings to serve as catch points for vehicles which could significantly increase the severity of accidents if the rail were hit. In addition, the maximum clear opening of 6 inches was established to minimize the potential for bodies and/or body parts to move through the clear openings during an accident, potentially resulting in injury or death. The larger railing base is required to minimize the potential for vehicles to travel through the rail or over the rail and off the bridge. For these reasons, Caltrans cannot, and will not, sacrifice any level of public safety by making a design exception to the bridge railing design specifications for this important safety feature.

Caltrans has repeatedly stated that the Garrapata Creek Bridge railing is "damaged beyond repair," the railing is "deemed not to be crash-worthy at any speed," and must be replaced now.

Denial of the project would hinder Caltrans' ability to ensure public safety on the Garrapata Creek Bridge resulting in delay of implementation of the project and exacerbating risk to public safety.

Denial of the Project is in Conflict with Monterey County's Public Access Policies

Because Caltrans is mandated to protect the public along the State Highway System, "Caltrans may restrict the use of, or close, any State highway whenever the department considers such closing or restriction of use necessary (Section 124, Streets and Highways Code)." Denial of the project by the County would directly increase the chances that Caltrans must close or restrict the use of State Route 1 in the Garrapata Creek Bridge area, which could also adversely affect public access to other areas on the Big Sur coast along State Route 1. Therefore, denial of the project would be in conflict with California Coastal Act as well as County policies regarding coastal public access including the following:

Coastal Act Section 30210: *In carrying out the requirement of Section 4 of Article X of the California Constitution, maximum access, which shall be conspicuously posted, and recreational opportunities shall be provided for all the people consistent with public safety needs and the need to protect public rights, rights of private property owners, and natural resource areas from overuse.*

Coastal Act Section 30211: *Development shall not interfere with the public's right of access to the sea where acquired through use or legislative authorization, including, but not limited to, the use of dry sand and rocky coastal beaches to the first line of terrestrial vegetation.*

Coastal Act Section 30213: *Lower cost visitor and recreational facilities shall be protected, encouraged, and, where feasible, provided. Developments providing public recreational opportunities are preferred.*

Big Sur Coast Land Use Plan 6.1.3: *The rights of access to the shoreline, public lands, and along the coast, and opportunities for recreational hiking access, shall be protected, encouraged and enhanced.*

It should also be noted that visual access in the Big Sur area cannot be accomplished without adequate safe physical access to these areas. Highway 1 facilitates the visual access.

Denial of the Project is in Conflict with Monterey County's Public Safety Policies

Denial of the project would hinder Caltrans' ability to ensure public safety on the Garrapata Creek Bridge resulting in delay of implementation of the project and exacerbating risk to public safety. This would be in direct conflict with the following County policies regarding safety in the Big Sur Coastal Land Use Plan:

Big Sur Coast Land Use Plan Policy 4.1.2.1. *Improvements to Highway 1 shall be undertaken in order to increase its service capacity and safety, consistent with its retention as a scenic two-lane road.*

Big Sur Coast Land Use Plan Recommendation 4.2.4. *The County requests that Caltrans, in cooperation with Monterey and San Luis Obispo Counties and the U. S. Forest Service immediately begin a program of management of recreational use of Highway 1. The objectives of this program shall be to enhance public access and enjoyment of the Big Sur coast and the safety of Highway 1 by ensuring that service capacity at no time falls below Level of Service E or a minimum driving speed of 35 miles per hour and that Levels of Service D and C be obtained wherever the basic design of the highway permits.*

Big Sur Coast Land Use Plan Policy 6.1.4.6. *In providing for access, the County seeks to ensure that the rights of residents and property owners, including their peace, privacy, safety, health, and property are not jeopardized by unmanaged, inappropriate (as defined in policy 6.1.4.3), or irresponsible public access.*

Conclusion

In conclusion, replacement of the Garrapata Creek Bridge railing is a high priority for Caltrans and must be completed as expeditiously as possible.

We respect the local agency and community's value of the Garrapata Creek Bridge. Caltrans values this resource equally. We also respect the local agency's purview over land use decisions in the coastal zone. However, it is Caltrans belief that County denial of the Combined Development Permit for replacement of the railing in its deteriorated condition would exacerbate risk to public safety. We implore the Board of Supervisors to uphold our appeal and approve the project.

If you have any questions or concerns, please contact me at (805) 549-3161 or Mitch Dallas, Senior Coastal Resources Specialist at (805) 748-7004 or by e-mail sent to mitch.dallas@dot.ca.gov.

Sincerely,



SCOTT EADES
District Director

Enclosures:

1. Appeal Application Form
2. Planning Commission's Resolution for Denial (from March 8, 2022 Hearing)
3. Visual Simulations
4. Caltrans Structure Maintenance & Investigations' Bridge Inspection Report (September 25, 2009)
5. Texas Department of Transportation's C411 Bridge Railing Standard Plans
6. Adoption of the AASHTO LRFD Bridge Design Specifications, Eighth Edition with California Amendments (August 19, 2019)
7. Letter from State Bridge Engineer, Chief Division of Engineering Services (March 21, 2023)
8. MASH Memos

Garrapata Creek Bridge Railing Replacement Project (EA 05-1H800/0516000163)
(Combined Development Permit No. PLN220090)
March 21, 2023
Page 13

cc:

Mike Harrington, Legal Division, Caltrans Headquarters
Mitch Dallas, Senior Coastal Resources Specialist, Environmental Division, Caltrans District 5
Michelle Wilson, Coastal Planner, Environmental Division, Caltrans District 5
Carla Yu, Project Manager, Office of Project Management, Caltrans District 5
Jason Wilkinson, Deputy District Director, Environmental Division, Caltrans District 5
Kelly McClain, Chief, Maintenance Division, Caltrans District 5
Peter Hendrix, District Traffic Safety Engineer, Caltrans District 5
Daniel Leckie, Senior Architectural Historian, Environmental Division, Caltrans District 5
Kristen Langager, District Scenic Highway Coordinator, Design Division, Caltrans District 5
Greg Kaderabek, Bridge Railing Specialist, Division of Engineering Services (DES), Caltrans Headquarters
Scott Williams, Office Chief, GNEIS, Division of Environmental Analysis (DEA), Caltrans Headquarters
Kate Anderson, Coastal Program Manager, GNEIS, Division of Environmental Analysis (DEA), Caltrans Headquarters
Jeremy Ketchum, Chief, Division of Environmental Analysis (DEA), Caltrans Headquarters
Sean Drake, Senior Transportation Program Analyst, California Coastal Commission

Enclosure #1

Enclosure #2

**Before the Planning Commission
in and for the County of Monterey, State of California**

In the matter of the application of:

**CALIFORNIA DEPARTMENT OF TRANSPORTATION
(PLN220090)**

RESOLUTION NO. 23-011

Resolution by the Monterey County Planning
Commission:

- 1) Finding that denial of the project qualifies for a statutory exemption from CEQA per CEQA Guidelines section 15270; and
- 2) Denying a Combined Development Permit consisting of:
 - a. A Coastal Development Permit and Design Approval to allow the replacement of the bridge rails on the historic Garrapata Bridge;
 - b. A Coastal Development Permit to allow development within the Critical Viewshed;
 - c. A Coastal Development Permit to allow development within 750 feet of known archaeological resources, and
 - d. A Coastal Development Permit to allow development within 100 feet of environmentally sensitive habitat areas.

[Garrapata Bridge, Highway One (postmile 63.0),
Big Sur Land Use Plan, Coastal Zone]

Corrected on March 15, 2023 (This resolution corrects the previous resolution mailed on March 13, 2023)

The California Department of Transportation (CalTrans) application for the Garrapata Bridge Rail replacement project (Permit No. PLN220090) came on for a public hearing before the Monterey County Planning Commission on February 22, 2023 and March 8, 2023. Having considered all the written and documentary evidence, the administrative record, the staff report, oral testimony, and other evidence presented, the Planning Commission finds and decides as follows:

FINDINGS

1. **FINDING:** **PROCESS** – The County has processed the subject Combined Development Permit application [HCD-Planning File No. PLN220090/California Department of Transportation] (“Project”) in compliance with all applicable procedural requirements.
EVIDENCE: a) On June 1, 2022, pursuant to Monterey County Code (“MCC”) Chapter 20.82, California Department of Transportation (“Caltrans” or “Applicant”) filed an application for a discretionary permit to allow

to allow the replacement of bridge rails on the Garrapata Bridge on Highway One, Big Sur Coast Land Use Plan area, Coastal Zone.

- b) On July 1, 2022, 30 days after the filing of the application, the application was deemed complete by operation of law.
- c) The Monterey County Planning Commission held a duly-noticed public hearing on the application on February 22, 2023. 10 days in advance of the hearing, notices for public hearing were published in the Monterey County Weekly; posted at and near the project site; and mailed to vicinity property owners and interested parties.
- d) On February 22, 2023, the Monterey County Planning Commission adopted a motion of intent to deny the Project and directed staff to prepare a draft resolution of denial for consideration at the March 8, 2023 Planning Commission meeting. Reasons for denial of the permit are discussed in the Findings and Evidence below.
- e) The application, project plans, and related support materials submitted by the Applicant to Monterey County HCD-Planning for the proposed development found in Project File No. PLN220090.

2. FINDING: INCONSISTENCY – The project is inconsistent with the Monterey County Local Coastal Program, which includes Big Sur Coast Land Use Plan (LUP) and Monterey County Coastal Implementation Plan, Part 3 (CIP).

EVIDENCE: a) During the course of review of this application, the project has been reviewed for consistency with the text, policies, and regulations in:

- the 1982 Monterey County General Plan;
- Big Sur Land Coast Use Plan (LUP);
- Monterey County Coastal Implementation Plan, Part 3 (CIP);
- Monterey County Coastal Zoning Ordinance (Title 20); and
- Preservation of Historic Resources (Monterey County Code Chapter 18.25)

Communications were received during the course of review of the project indicating inconsistencies with the text, policies, and regulations in these documents, specifically the Big Sur Coast Land Use Plan policies related to viewshed and historic resources. Comments have been considered.

- b) The Project is located on State Route (“Highway” or “Hwy”) 1 (postmile 63) in Big Sur. The development includes replacement of bridge rails on the Garrapata Creek Bridge. Hwy 1 is a public highway under the jurisdiction of Caltrans.
- c) In accordance with the California Coastal Act, the County has a certified Local Coastal Program, the Monterey County Local Coastal Program (LCP). Once a local government has a certified LCP, they retain primary Coastal Development Permitting responsibility. Both public and private property owners are subject to the Coastal Development Permitting process and requirements. The Monterey County LCP contains four land use plans “LUPs”, and the Monterey County Coastal Implementation Plan (CIP). Part 1 of the CIP is the Zoning Ordinance (Title 20), and Part 3 is the development standards within the Big Sur Coast Land Use Plan Area. For the County to approve a Coastal Development Permit, the appropriate authority must

make a finding that the subject project is in conformance with the Monterey County Local Coastal Program (Title 20 section 20.70.050.B.3).

- d) The highway was built in the 1930s and was the first scenic highway in California's Scenic Highway System. LUP Key Policy 4.1.1 states that Monterey County will take a strong and active role in guiding the use and improvement of Highway One and land use development dependent on the highway. The County's objective is to maintain and enhance the highway's aesthetic beauty and to protect its primary function as a recreational route.
- e) LUP General Policy 4.1.2.2 indicates that a principal objective of management, maintenance, and construction activities within the Highway 1 right-of-way shall be to maintain the highest possible standard of visual beauty and interest.
- f) LUP Public Access Key Policy 6.1.3 indicates protection of visual access should be emphasized throughout Big Sur as an appropriate response to the needs of recreationists, and General Policy 6.1.4.4 indicates visual access should be protected for long term public use.
- g) Taken together the policies of the LUP and their implementing regulations in the CIP require the highest possible degree of protection for Highway 1's aesthetic beauty. The project proposes replacement of the bridge rails on the Garrapata Creek Bridge. The bridge is one of seven iconic known as the "Big Sur Arches", each of which are eligible for listing on the state and national historic registers and are contributing features to the Carmel San Simeon Highway Historic District, and are important for their role in maintaining Big Sur's iconic coastal views. The replacement rails would have narrower openings, going from 10 inch squared to 6 inches with a 1.5 inch chamfered window, and a shorter opening arch height, going from 20 inches to approximately 15 inches. The rails also have secondary support strong posts which further interrupt the viewshed. The smaller openings, thicker bottom rail and added strong posts would adversely impact public views, as the existing larger openings frame views outward of the ocean and dramatic coast line. These impacts to visual resources require a statement of overriding consideration as determined by Caltrans acting the lead agency on the project. This project has the potential to impact future considerations on other "Big Sur Bridge Rails" as those rail replacements may be proposed in the future, and cumulative analysis of the Aesthetics impacts for those bridges should be incorporated holistically to ensure consistency with the Big Sur Coast Land Use Plan's policies.
- h) Exploration of non-standard bridge rail alternatives that maximize protection of the viewshed and this iconic bridge while protecting health and safety must be explored. In this case, Caltrans proposes a modified bridge rail that is compliant with current standards for the high speeds but has not demonstrated that other design options have been given adequate consideration. Options for repair, speed reductions, bridge rail openings, and relief from typical crash test rating standards are discussed in the evidences that follow.

- i) Repair. County staff asked if the bridge rails could be rehabilitated, generally, and notwithstanding Caltrans standards. In the Caltrans supplemental package dated December 6, 2022, District Chief of Maintenance and Caltrans' Structures Maintenance & Investigations (SM&I) states "Because the bridge rail is a safety feature, it must be brought up to MASH standards. Therefore, replacement is the only repair strategy." Whether repair is possible and if so what speed/traffic a repaired rail would be safe should be explored further.
- j) Speed Reduction. One of the identified alternatives in the project EIR is reducing the speed limit to 45 miles an hour, which would allow utilizing what the Manual for Assessing Safety Hardware (MASH) calls a "TR-2" rail, as opposed to the proposed "TR-4" rail, which could have taller (but not wider) openings, closer to the aesthetic of the original rails. Despite conducting a speed zone survey in 2019 and determining that the operating speed at the bridge is 58 miles an hour, it is unclear if options for reduced speed zone and other traffic calming or control devices to induce lower speeds have been sufficiently explored in this case.
- k) Width of Opening. In the EIR the identified purpose of the narrower opening is to prevent catch points, which can hook cars bumpers and increase the severity of accidents. The health and safety need for the features creating additional obstruction to the viewshed should be clarified and confirmed.
- l) Manual for Assessing Safety Hardware (MASH). The 2019 Mash Implementation Memo submitted by CalTrans indicates that as of December 23, 2016, Caltrans will no longer allow installation of non-MASH compliant safety devices. Nevertheless, out of consideration of the critical importance of Big Sur's scenic and historical resources, the potential for an exception to these rules should be taken to the highest possible approval body.
- m) Land Use Advisory Committee (LUAC) Review. On November 8, 2022, the Big Sur Land Use Advisory Committee (LUAC) considered the proposed project. The LUAC recommend approval with changes by a vote of 4 ayes to 1 no. Comments were made that the reduced opening sizes in the proposed replacement rails obscure the viewshed and the openings should be widened to their original height and width and that the historic design be maintained while attempting to meet current safety standards.
- n) Historic Resources Review Board. On January 25, 2023, the Historic Resources Review Board (HRRB) considered the proposed project. After receiving additional information on the design and justification, the HRRB 6-0 with 1 absent to recommend approval of the project with 2 conditions. The first condition is that the final color be approved by the Chief of Planning to match the existing rails as closely as possible, and the second condition was that speed studies and other alternatives be explored for each bridge.
- o) The application, project plans, and related support materials submitted by the project applicant to Monterey County HCD-Planning found in Project File PLN220090.

3. **FINDING:** **HEALTH AND SAFETY** – Denial of the Project applied for will not under the circumstances of this particular case be detrimental to the health, safety, peace, morals, comfort, and general welfare of persons residing or working in the neighborhood of such proposed use, or be detrimental or injurious to property and improvements in the neighborhood or to the general welfare of the County.
- EVIDENCE:** a) The existing bridge rails on Garrapata Bridge are deteriorating and do not meet current bridge rail design standards. The bridge rails were originally constructed in the 1930's and have remained in their current configuration and location since that time. There are no documented incidents involving the bridge rail since its construction. Despite the lack of past incidents, temporary measures may be needed to secure the bridge rails for current and future travelers until a permanent solution is provided.
4. **FINDING:** **CEQA (Exempt)** – Denial of the project is statutorily exempt from environmental review.
- EVIDENCE:** a) California Environmental Quality Act (CEQA) Guidelines section 15270 statutorily exempts projects which a public agency rejects or disapproves.
- b) The Planning Commission's action to deny the project fits within this exemption, the County is a public agency disapproving of a project.
- c) Statutory exemptions from CEQA are not qualified by the exceptions applicable to categorical exemptions in CEQA Guidelines section 15300.2.
5. **FINDING:** **APPEALABILITY** – The decision on this project may be appealed to the Board of Supervisors and the California Coastal Commission.
- EVIDENCE:** a) Pursuant to Title 20 Section 20.86.080, the Project is subject to appeal by/to the Coastal Commission because it involves development that is a major public works project pursuant to Title 20 section 20.86.080.A.4.
- b) Section 20.80.040.D of the Monterey County Zoning Ordinance states that the proposed project is appealable to the Board of Supervisors.

DECISION

NOW, THEREFORE, based on the above findings and evidence, the Monterey County Planning Commission does hereby:

- 1) Find that denial of the project qualifies for a statutory exemption from CEQA per CEQA Guidelines section 15270; and
- 2) Deny a Combined Development Permit consisting of:
 - a. A Coastal Development Permit and Design Approval to allow the replacement of the bridge rails on the historic Garrapata Bridge;
 - b. A Coastal Development Permit to allow development within the Critical Viewshed;
 - c. A Coastal Development Permit to allow development within 750 feet of known archaeological resources, and
 - d. A Coastal Development Permit to allow development within 100 feet of environmentally sensitive habitat areas.

PASSED AND ADOPTED this 8th day of March, 2023 upon motion of Commissioner Roberts, seconded by Commissioner Daniels, by the following vote:

AYES: Daniels, Gonzalez, Work, Monsalve, Mendoza, Roberts
NOES: Getzelman
ABSENT: None
ABSTAIN: None
RECUSED: Diehl

DocuSigned by:
Craig Spencer
188DB67A496E45L
Craig Spencer, Secretary

COPY OF THIS DECISION MAILED TO APPLICANT ON MAR 13 2023.

THIS APPLICATION IS APPEALABLE TO THE BOARD OF SUPERVISORS. IF ANYONE WISHES TO APPEAL THIS DECISION, AN APPEAL FORM MUST BE COMPLETED AND SUBMITTED TO THE CLERK TO THE BOARD ALONG WITH THE APPROPRIATE FILING FEE ON OR BEFORE MAR 23 2023.

THIS PROJECT IS LOCATED IN THE COASTAL ZONE AND IS APPEALABLE TO THE COASTAL COMMISSION. UPON RECEIPT OF NOTIFICATION OF THE FINAL LOCAL ACTION NOTICE (FLAN) STATING THE DECISION BY THE FINAL DECISION MAKING BODY, THE COMMISSION ESTABLISHES A 10 WORKING DAY APPEAL PERIOD. AN APPEAL FORM MUST BE FILED WITH THE COASTAL COMMISSION. FOR FURTHER INFORMATION, CONTACT THE COASTAL COMMISSION AT (831) 427-4863 OR AT 725 FRONT STREET, SUITE 300, SANTA CRUZ, CA.

This decision, if this is the final administrative decision, is subject to judicial review pursuant to California Code of Civil Procedure Sections 1094.5 and 1094.6. Any Petition for Writ of Mandate must be filed with the Court no later than the 90th day following the date on which this decision becomes final.

Enclosure #3

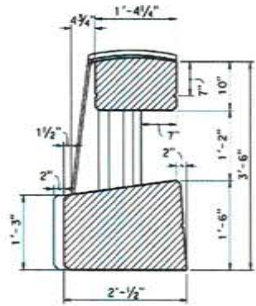

TYPE 86H SECTION



TYPE 86H ON DECK VIEW

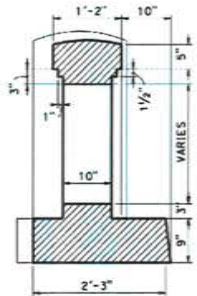

EXISTING SECTION



EXISTING ON DECK VIEW

GARRAPATA CREEK BRIDGE BARRIER STUDY

01/05/22

Prepared by: DES, Bridge Architecture and Aesthetics





86H FRONT ELEVATION PHOTO SIM.

GARRAPATA CREEK BRIDGE BARRIER TYPE 86H

09/06/22

Prepared by: DES, Bridge Architecture and Aesthetics



Enclosure #4



DEPARTMENT OF TRANSPORTATION
Structure Maintenance & Investigations

Bridge Number : 44 0018
Facility Carried: STATE ROUTE 1
Location : 05-MON-001-62.97
City :
Inspection Date : 09/25/2009

Bridge Inspection Report

Inspection Type
Routine FC Underwater Special Other

STRUCTURE NAME: GARRAPATA CREEK

CONSTRUCTION INFORMATION

Year Built : 1931 Skew (degrees): 0
Year Widened: N/A No. of Joints : 0
Length (m) : 87 No. of Hinges : 0

Structure Description: RC open-spandrel arch and RC girder (2) approach spans on RC column
(2) bents all founded on spread footings.

Span Configuration : 4 @ 25', 1 @ 5', 1 @ 150', 1 @ 5', 1 @ 25' (N).

LOAD CAPACITY AND RATINGS

Design Live Load: MS-13.5 OR HS-15
Inventory Rating: 36 metric tonnes Calculation Method: LOAD FACTOR
Operating Rating: 59.6 metric tonnes Calculation Method: LOAD FACTOR
Permit Rating : PFFFF
Posting Load : Type 3: Legal Type 3S2: Legal Type 3-3: Legal

DESCRIPTION ON STRUCTURE

Deck X-Section: 1' br, 0.7' cu, 24', 0.7' cu, 1' br.
Total Width: 8.3 m Net Width: 7.3 m No. of Lanes: 2
Rail Description: Concrete baluster. Rail Code : 0111
Min. Vertical Clearance: Unimpaired

DESCRIPTION UNDER STRUCTURE

Channel Description: Coastal mountain bedrock channel with steep gradient. Sand, gravel, and bedrock in the channel. Narrow section in active channel. Heavy vegetation on high flow sides of channel.

CONDITION TEXT

REVISIONS

The full quantity of Element 331 was down graded to condition state 4 due to the advanced deterioration of the railing.

CONDITION OF STRUCTURE

Access

Due to the height of the bridge, the approaches, railing, deck, joints, and abutments were inspected visually at close range. The soffit and the substructure were inspected with binoculars. The last close up access to the soffit appears to have been during the seismic retrofit in 1998. A UBIT assisted inspection will be scheduled when the 2012 UBIT schedule is released.

Deck & Rail

The rail end posts are covered with fine pattern cracking. See the attached photo. The barrier rail posts are highly deteriorated, with dozens of incipient spalls and five fully spalled posts. No work was recommended since there was an existing STRAIN

CONDITION TEXT

recommendation for a rail upgrade (Fiscal Year 2001). However, the railing needs replacement. An e-mail was sent to Roger Hunter 2/24/11 requesting the rail replacement be expedited.

The deck has a full width transverse crack between 1/64" and 1/16" on the main arch span, between sets of spandrel columns. See the attached photos. Minor deck cracking is common and does not reduce the ultimate capacity of the superstructure.

Superstructure

Efflorescence can be seen in the soffit at the joints. The joints were filled with mortar when the structure was made continuous during the retrofit.

Substructure

Arch:

There is an incipient spall at the top of the west rib at the bottom of SC-6 approximately 2' x 0.7'.

Columns:

The south face of the right column at Bent 3, has a vertical spall approximately 6" x 2" with exposed corroded reinforcing steel. Two smaller spalls are just below the upper spall. See the attached photos. This kind of spalling is common and is due to a combination of inadequate cover over the reinforcing steel and the high chloride content of the marine air. Many spalls were documented through the years and were patched.

Left and right spandrel columns 1 were patched. However, pattern cracking was noted in the patches; indicating the patches will eventually fail. See the attached photo. This was noted with the aid of binoculars.

It was noted through binoculars that in the main span, on the right right side, the first spandrel column appears to have map cracking in most of the column.

There is an incipient spall approximately 3" wide x 2' long at Bent 3, left column, mid height, SW corner. There is also map cracking less than 1/64" wide on the patches on both columns.

There is an incipient spall approximately 6" wide x 2.5' long at Bent 4, left column, base of NW corner.

Transverse Strut:

There is a crack in the SW face of the bottom strut near SC-4. The crack averages 1/8" wide x 1.5' long.

Spalling on the bridge railing and spandrel columns has been documented since the 1956 inspection report. Apparently, the condition will be ongoing unless new material for patching and sealing the concrete can be found.

SAFE LOAD CAPACITY

The spandrel spans and approach spans were rated in 1975 and the arches rated in 1978, the lower and more conservative ratings were for the spandrel spans are used. Rating factors were calculated with the Load Factor method using 0" AC. Based on an operating rating of 2.16, this bridge should sustain the State legal and permit loads.

CONDITION TEXT

HS20-44 design truck: Inventory Rating = 36 metric tons Rating Factor: 1.11

HS20-44 design truck: Operating Rating = 60 metric tons Rating Factor: 1.84

Permit: rating factor = 1.47 P P P P P

MISCELLANEOUS

A request was sent to Mike Lee of Maintenance Design on 2/24/2011 to produce a set of plan and elevation drawings that can be used as a template for noting element deficiencies.

This bridge is NBI labeled "Functionally Obsolete" due to the high ADT / bridge deck width ratio.

<u>ELEMENT INSPECTION RATINGS</u>									
Elem No.	Element Description	Env	Total		Qty in each Condition State				
			Qty	Units	St. 1	St. 2	St. 3	St. 4	St. 5
12	Concrete Deck - Bare	3	730	sq.m.	730	0	0	0	0
44	Concrete Slab - Protected w/ Thin Overlay	2	750	sq.m.	750	0	0	0	0
110	Reinforced Conc Open Girder/Beam	3	174	m.	90	84	0	0	0
144	Reinforced Conc Arch	3	75	m.	74	1	0	0	0
155	Reinforced Conc Floor Beam	2	55	m.	55	0	0	0	0
205	Reinforced Conc Column or Pile Extension	3	26	ea.	22	4	0	0	0
215	Reinforced Conc Abutment	2	16	m.	16	0	0	0	0
320	P/S Concrete Approach Slab w/ or w/o/AC Ovly	2	4	ea.	4	0	0	0	0
331	Reinforced Conc Bridge Railing	3	186	m.	12	0	0	174	0
358	Deck Cracking	2	1	ea.	0	1	0	0	0

WORK RECOMMENDATIONS

RecDate: 09/25/2009 EstCost: \$2,000 Remove all unsound concrete and loose
 Action : Railing-Rehab StrTarget: 2 YEARS rust, then recast the affected areas.
 Work By: MAINT. CONTRACT DistTarget:
 Status : PROPOSED EA:

RecDate: 02/10/1984 EstCost: \$324,720 F1-03 / F2-0 / F3-0 / Rail Type-C.WIN
 Action : Railing-Upgrade StrTarget: 2 YEARS
 Work By: STRAIN DistTarget:
 Status : PROPOSED EA:

Inspected By : R. Fuentes / Y.Huang

Ricardo Fuentes
Ricardo L. Fuentes (Registered Civil Engineer)



STRUCTURE INVENTORY AND APPRAISAL REPORT

```

***** IDENTIFICATION *****
(1) STATE NAME- CALIFORNIA 069
(8) STRUCTURE NUMBER 44 0018
(5) INVENTORY ROUTE (ON/UNDER) - ON 131000010
(2) HIGHWAY AGENCY DISTRICT 05
(3) COUNTY CODE 053 (4) PLACE CODE 00000
(6) FEATURE INTERSECTED- GARRAPATA CREEK
(7) FACILITY CARRIED- STATE ROUTE 1
(9) LOCATION- 05-MON-001-62.97
(11) MILEPOINT/KILOMETERPOINT 62.97
(12) BASE HIGHWAY NETWORK- PART OF NET 1
(13) LRS INVENTORY ROUTE & SUBROUTE 000000000101
(16) LATITUDE 36 DEG 25 MIN 06 SEC
(17) LONGITUDE 121 DEG 54 MIN 42 SEC
(98) BORDER BRIDGE STATE CODE % SHARE %
(99) BORDER BRIDGE STRUCTURE NUMBER

***** STRUCTURE TYPE AND MATERIAL *****
(43) STRUCTURE TYPE MAIN:MATERIAL- CONCRETE
TYPE- ARCH - DECK CODE 111
(44) STRUCTURE TYPE APPR:MATERIAL- CONCRETE CONT
TYPE- TEE BEAM CODE 204
(45) NUMBER OF SPANS IN MAIN UNIT 1
(46) NUMBER OF APPROACH SPANS 7
(107) DECK STRUCTURE TYPE- CIP CONCRETE CODE 1
(108) WEARING SURFACE / PROTECTIVE SYSTEM:
A) TYPE OF WEARING SURFACE- NONE CODE 0
B) TYPE OF MEMBRANE- NONE CODE 0
C) TYPE OF DECK PROTECTION- NONE CODE 0
***** AGE AND SERVICE *****
(27) YEAR BUILT 1931
(106) YEAR RECONSTRUCTED 0000
(42) TYPE OF SERVICE: ON- HIGHWAY 1
UNDER- WATERWAY 5
(28) LANES:ON STRUCTURE 02 UNDER STRUCTURE 00
(29) AVERAGE DAILY TRAFFIC 4500
(30) YEAR OF ADT 2000 (109) TRUCK ADT 3 %
(19) BYPASS, DETOUR LENGTH 199 KM
***** GEOMETRIC DATA *****
(48) LENGTH OF MAXIMUM SPAN 45.7 M
(49) STRUCTURE LENGTH 87.0 M
(50) CURB OR SIDEWALK: LEFT 0.2 M RIGHT 0.2 M
(51) BRIDGE ROADWAY WIDTH CURB TO CURB 7.3 M
(52) DECK WIDTH OUT TO OUT 8.3 M
(32) APPROACH ROADWAY WIDTH (W/SHOULDERS) 7.3 M
(33) BRIDGE MEDIAN- NO MEDIAN 0
(34) SKEW 0 DEG (35) STRUCTURE FLARED NO
(10) INVENTORY ROUTE MIN VERT CLEAR 99.99 M
(47) INVENTORY ROUTE TOTAL HORIZ CLEAR 7.3 M
(53) MIN VERT CLEAR OVER BRIDGE RDWY 99.99 M
(54) MIN VERT UNDERCLEAR REF- NOT H/RR 0.00 M
(55) MIN LAT UNDERCLEAR RT REF- NOT H/RR 0.0 M
(56) MIN LAT UNDERCLEAR LT 0.0 M
***** NAVIGATION DATA *****
(38) NAVIGATION CONTROL- NO CONTROL CODE 0
(111) PIER PROTECTION- CODE
(39) NAVIGATION VERTICAL CLEARANCE 0.0 M
(116) VERT-LIFT BRIDGE NAV MIN VERT CLEAR M
(40) NAVIGATION HORIZONTAL CLEARANCE 0.0 M

***** SUFFICIENCY RATING = 61.0
STATUS FUNCTIONALLY OBSOLETE
HEALTH INDEX 93.0
PAINT CONDITION INDEX = N/A
***** CLASSIFICATION ***** CODE
(112) NBIS BRIDGE LENGTH- YES Y
(104) HIGHWAY SYSTEM- NOT ON NHS 0
(26) FUNCTIONAL CLASS- MINOR ARTERIAL RURAL 06
(100) DEFENSE HIGHWAY- NOT STRAHNET 0
(101) PARALLEL STRUCTURE- NONE EXISTS N
(102) DIRECTION OF TRAFFIC- 2 WAY 2
(103) TEMPORARY STRUCTURE-
(105) FED.LANDS HWY- NOT APPLICABLE 0
(110) DESIGNATED NATIONAL NETWORK - NOT ON NET 0
(20) TOLL- ON FREE ROAD 3
(21) MAINTAIN- STATE HIGHWAY AGENCY 01
(22) OWNER- STATE HIGHWAY AGENCY 01
(37) HISTORICAL SIGNIFICANCE- ELIGIBLE 2
***** CONDITION ***** CODE
(58) DECK 6
(59) SUPERSTRUCTURE 6
(60) SUBSTRUCTURE 6
(61) CHANNEL & CHANNEL PROTECTION 6
(62) CULVERTS N
***** LOAD RATING AND POSTING ***** CODE
(31) DESIGN LOAD- MS-13.5 OR HS-15 3
(63) OPERATING RATING METHOD- LOAD FACTOR 1
(64) OPERATING RATING- 59.6
(65) INVENTORY RATING METHOD- LOAD FACTOR 1
(66) INVENTORY RATING- 36
(70) BRIDGE POSTING- EQUAL TO OR ABOVE LEGAL LOADS 5
(41) STRUCTURE OPEN, POSTED OR CLOSED- A
DESCRIPTION- OPEN, NO RESTRICTION
***** APPRAISAL ***** CODE
(67) STRUCTURAL EVALUATION 6
(68) DECK GEOMETRY 2
(69) UNDERCLEARANCES, VERTICAL & HORIZONTAL N
(71) WATER ADEQUACY 9
(72) APPROACH ROADWAY ALIGNMENT 8
(36) TRAFFIC SAFETY FEATURES 0111
(113) SCOUR CRITICAL BRIDGES 9
***** PROPOSED IMPROVEMENTS *****
(75) TYPE OF WORK- MISC STRUCTURAL WORK CODE 38
(76) LENGTH OF STRUCTURE IMPROVEMENT 87 M
(94) BRIDGE IMPROVEMENT COST $720,000
(95) ROADWAY IMPROVEMENT COST $144,000
(96) TOTAL PROJECT COST $1,209,600
(97) YEAR OF IMPROVEMENT COST ESTIMATE 2010
(114) FUTURE ADT 7334
(115) YEAR OF FUTURE ADT 2029
***** INSPECTIONS *****
(90) INSPECTION DATE 09/09 (91) FREQUENCY 24 MO
(92) CRITICAL FEATURE INSPECTION: (93) CFI DATE
A) FRACTURE CRIT DETAIL- NO MO A)
B) UNDERWATER INSP- NO MO B)
C) OTHER SPECIAL INSP- NO 96 MO C)

```



Photo #2
Typical deck crack size.



Photo #3
Pattern cracking on bridge rail end posts.



Photo #4
Gross deterioration of bridge railing.



Photo #5
Gross deterioration of bridge railing.



Photo #6
Gross deterioration of bridge railing.

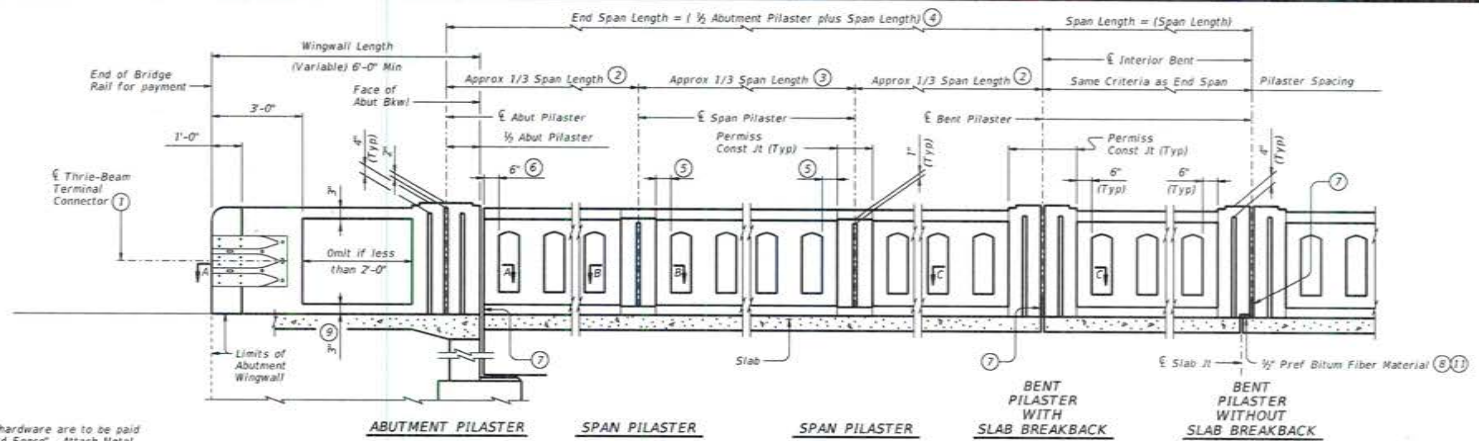

Photo #7
Gross deterioration of bridge railing.

Enclosure #5

DISCLAIMER: The use of this standard is governed by the Texas Engineering Practice Act. No warranty of any kind is made by the Department of Transportation for incorrect results or damages resulting from its use.

DATE: FILE:



- 1 Terminal Connectors and associated hardware are to be paid for under the Item "Metal Beam Guard Fence". Attach Metal Beam Guard Fence Transitions to the bridge rail and extend along the embankment unless otherwise shown in the plans.
- 2 Number of windows in interior bays are equal.
- 3 Number of windows in interior bay(s) are not less than the amount in exterior bays (Note 2).
- 4 Space Span Pilasters at 1/3 span length (Approx) when spans are 100 ft and less, as shown. Space Span Pilasters at 1/5 span length (Approx) for spans greater than 100 ft.
- 5 Dimension is the same for all posts adjacent to Span Pilasters in a span. Dimension may vary from span to span. Min = 3', Max = 7 1/2'.
- 6 Min = 6", Max = 1'-3".
- 7 Provide rail joints at ends of all spans the same width as Slab joint opening, except that Rail Joints over construction joints must be 1/2" Min to 3/4" Max in width. Joints must be open if slab joint opening is not sealed. Joints over construction joints and over sealed deck joints must be plugged. Forming material used in joints may be left in place if it is light in color and compressible, such as the following materials: polystyrene, molded cork granules, sponge rubber sheet, etc. If forming material is not left in place, plug the bottom 6" with slab joint sealing compound to prevent drainage and staining.
- 8 Place Preformed Bituminous Fiber Material between slab and rail when rail extends over expansion joint. Shift Bars U as necessary.
- 9 Increase 2" for structures with overlay.
- 10 Place 4 additional Bars WH(#5) 3'-8" in length inside Bars S(#5) and centered 2'-0" from end of rail when Terminal Connections are required. Field bend as needed.
- 11 Shift U Bars from region below 1/2" Preformed Bituminous Fiber Material at joints.

ROADWAY ELEVATION OF RAIL
(Showing without raised sidewalk)

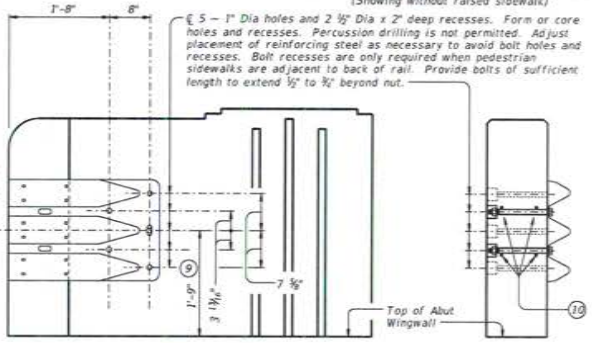

TERMINAL CONNECTION DETAILS
(Showing parapet with Pilaster on 6'-0" Wingwall)

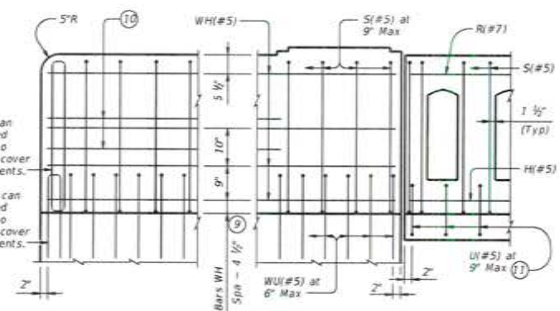

ELEVATION SHOWING TYPICAL REINFORCING PLACEMENT
(Showing without raised sidewalk)

The use of this railing is restricted to speeds of 45 mph or less.

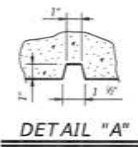
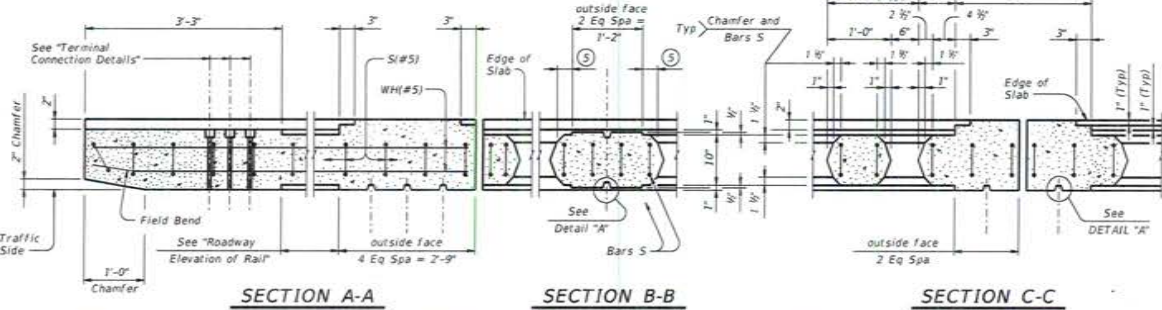

Texas Department of Transportation		Bridge Division Standard	
COMBINATION RAIL TEXAS CLASSIC			
TYPE C411			
FILE: r1c411-20.dgn	DR: TADOT	CK: TADOT	IN: TADOT
DATE: September 2019	CONT: 4217	ISS: 1	REVISION:
7-00: 0-0000 (see change to and modification)	SIST:	COUNTY:	SHEET NO.:

DISCLAIMER: This standard is governed by the Texas Engineering Practice Act. No warranty of any kind is made by TxDOT for any purpose whatsoever. TxDOT assumes no responsibility for the conversion of this standard to other formats or for increased results or damages resulting from its use.

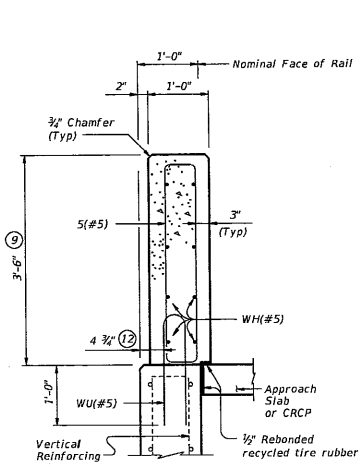

ON ABUTMENT WINGWALLS OR CIP RETAINING WALLS

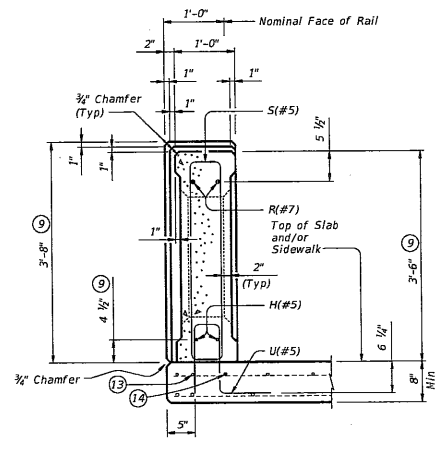

SECTION THRU POST ON BRIDGE SLAB (Showing Pillaster)

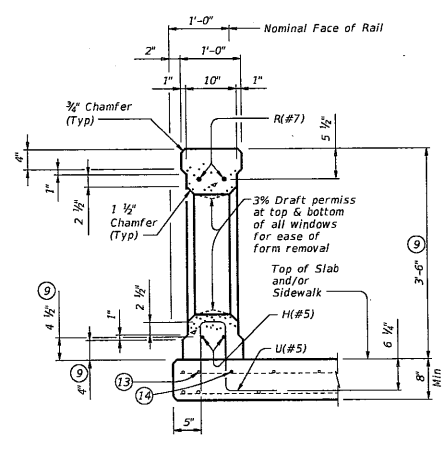

SECTION THRU WINDOW ON BRIDGE SLAB

SECTIONS THRU RAIL WITHOUT RAISED SIDEWALK

- ⑨ Increase 2" for structures with overlay.
- ⑫ 5 1/4" when vertical reinforcing has closer clear cover over horizontal reinforcing in abutment wingwalls or retaining walls on traffic side of wall.
- ⑬ As an aid in supporting reinforcement, additional longitudinal bars may be used in the slab with the approval of the Engineer. Such bars must be furnished at the Contractor's expense.
- ⑭ Top longitudinal slab bar may be adjusted laterally 3" plus or minus to tie reinforcing.
- ⑮ Raised Sidewalk

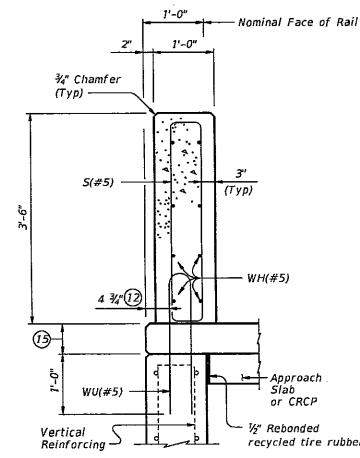

ON ABUTMENT WINGWALLS OR CIP RETAINING WALLS

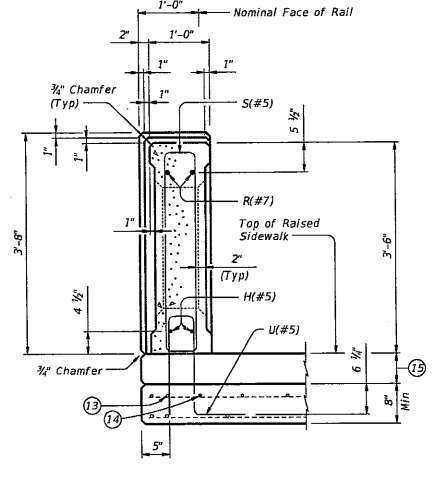

SECTION THRU POST ON BRIDGE SLAB (Showing Pillaster)

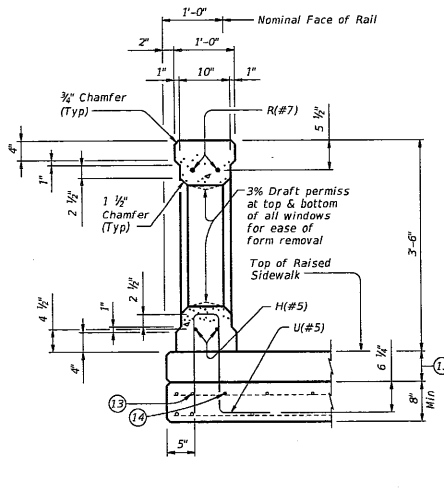

SECTION THRU WINDOW ON BRIDGE SLAB

SECTIONS THRU RAIL WITH RAISED SIDEWALK

		Bridge Division Standard	
COMBINATION RAIL TEXAS CLASSIC			
TYPE C411			
FILE: r1std021-20.dgn	DATE: TxDOT	CHK: TxDOT	DRW: TxDOT
© TxDOT September 2019	CONV: JCS	SECT: JCS	REVISION: HIGHWAY
7-20: BRIDGE STAR change to one manufacturer		DIST:	COUNTY:
		SHEET NO.	

DATE: FILE:

DISCLAIMER:
The use of this standard is governed by the Texas Engineering Practice Act. No warranty of any kind is made by TxDOT for any purpose whatsoever. TxDOT assumes no responsibility for the conversion of this standard to other formats or for incorrect results or damages resulting from its use.

DATE:
FILE:

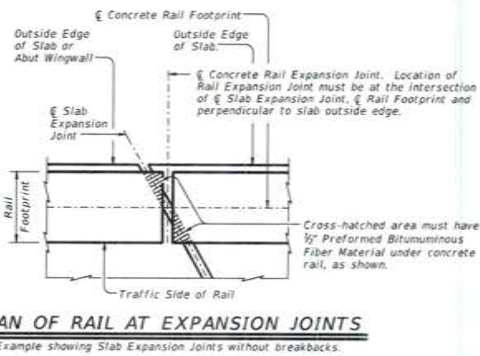
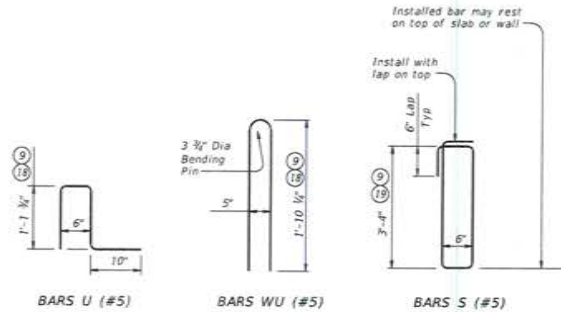
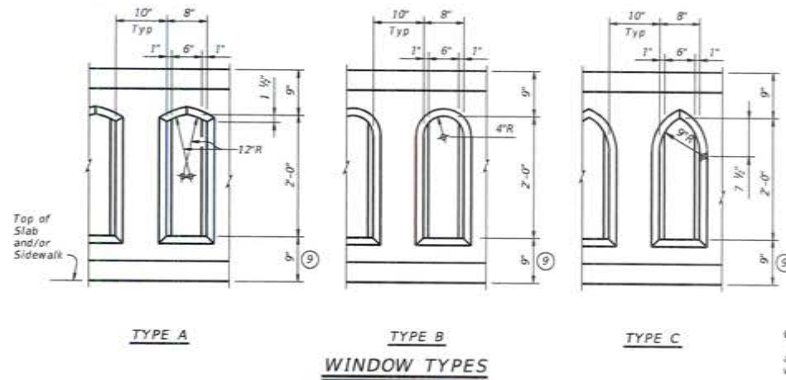
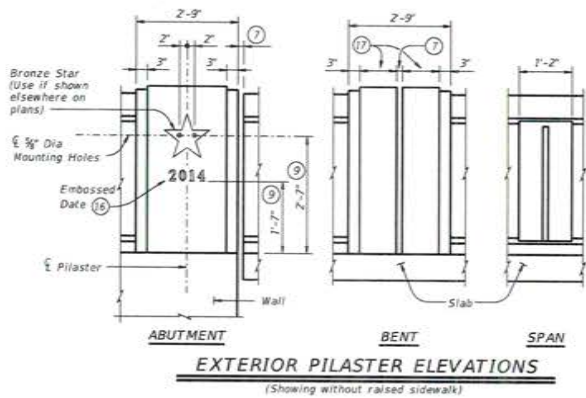

CONSTRUCTION NOTES:
Attach Bronze Star with a Type III Class C, D, E, or F epoxy adhesive. Clamp star until epoxy achieves set. Remove any visible epoxy "squeeze out" from under star.
Face of rail and pilasters, parapet must be plumb unless otherwise approved.
Apply a one rub finish to all railing surfaces unless otherwise shown elsewhere on the plans.

MATERIAL NOTES:
Provide Class "C" concrete for railing. Provide Class "C" (HPC) concrete if shown elsewhere in the plans.
Provide Grade 60 reinforcing steel.
Epoxy coat or galvanize all reinforcing steel if slab bars are epoxy coated or galvanized.
Bronze Star must be cast of architectural bronze having the following composition: Copper 85 %, Tin 5 %, Lead 5 %, Zinc 5 %.
Provide bar laps, where required, as follows:
Uncoated or galvanized - #5 = 2'-0"
Uncoated or galvanized - #7 = 2'-11"
Epoxy coated - #5 = 3'-0"
Epoxy coated - #7 = 4'-4"

GENERAL NOTES:
This rail has been successfully evaluated by full-scale crash test to meet MASH TL-2 criteria. This rail can be used for speeds of 45 mph and less when a TL-2 or TL-3 rated guard fence transition is used. This rail is only approved for low speed use, speeds of 45 mph and less.
Do not use this railing on bridges with expansion joints providing more than 5" movement.
Rail anchorage details shown on this standard may require modification for select structure types. See appropriate details elsewhere in plans for these modifications.
Shop drawings will not be required for this rail.
See Bridge Layout or other plan sheets for the following: dimensions with the number of span pilasters, dimensions with the number of windows, window type, inclusion of bronze stars, inclusion of construction year with abutment identity.
Submit erection drawings showing span number, span pilaster locations, number of windows between pilasters and spacing to first window (see Note 6) to the Engineer for approval.
Average weight of railing with no overlay increase and no pilasters is 350 plf.
Cover dimensions are clear dimensions, unless noted otherwise.
Reinforcing bar dimensions shown are out-to-out of bar.

- 1) Provide rail joints at ends of all spans the same width as Slab joint opening, except that Rail Joints over construction joints must be 1/4" Min to 1/2" Max in width. Joints must be open if slab joint opening is not sealed. Joints over construction joints and over sealed deck joints must be plugged. Forming material used in joints may be left in place if it is light in color and compressible, such as the following materials: polystyrene, molded cork granules, sponge rubber sheet, etc. If forming material is not left in place, plug the bottom 6" with slab joint sealing compound to prevent drainage and staining.
- 2) Increase 2" for structures with overlay.
- 16) Construction year (use if shown elsewhere on plans) 3" High "Plantin Bold" Typeface with 1/4" recess. Placed at one Abutment only or as directed by the Engineer.
- 17) Dimensions must be the same on each side of joint.
- 18) For raised sidewalks, add sidewalk height to total bar height. Use sidewalk height at rail's location.
- 19) Reduce by 2" or field bend over Preformed Bituminous Fiber Material to gain cover.
- 20) Bronze Star dimensions of the final product can be slightly smaller due to shrinkage after casting.

SHEET 3 OF 3

COMBINATION RAIL TEXAS CLASSIC			
TYPE C411			
Proj:	ris2021-20.00	Rev:	TxDOT
Rev:	September 2019	Drawn:	JEH
Checked:		Reviewed:	
Approved:		Design:	
		Quantity:	
		Sheet No.:	

Enclosure #6

Memorandum

*Making Conservation
a California Way of Life*

To: STRUCTURE POLICY BOARD

Date: August 19, 2019

From: RUTH FERNANDES *RF*
State Bridge Engineer (A)
Deputy Division Chief (A)
Structure Policy & Innovation
Division of Engineering Services

Subject: **ADOPTION OF THE AASHTO LRFD BRIDGE DESIGN SPECIFICATIONS, EIGHTH EDITION WITH CALIFORNIA AMENDMENTS**

Effective November 1, 2019, the *AASHTO LRFD Bridge Design Specifications, Eighth Edition with California Amendments (AASHTO-CA BDS-8)*, constitutes the primary design specifications for California bridges and transportation-related structures.

For projects under development, adoption of *AASHTO-CA BDS-8* is:

- Mandatory for all projects with a Type Selection approval on or after November 1, 2019.
- Optional if it would not impose a significant delay in the project schedule or a significant increase in the project engineering or construction costs. The project history notes and plans must indicate the design criteria used.

Caltrans' Standard Plans and Standard Specifications remain valid for use. If a project under development requires significant deviation from these standards, the design must meet the requirements of *AASHTO-CA BDS-8*.

The State Bridge Engineer shall approve any exceptions to adopting provisions in the *AASHTO-CA BDS-8* as stated above. This request shall be made as early as possible.

AASHTO-CA BDS-8 shall be the basis of all Caltrans' guidance material under development.

STRUCTURE POLICY BOARD

August 19, 2019

Page 2

For questions or concerns on the application of the AASHTO-CA BDS-8 on a specific project, consultants and local agencies should contact the Structure Liaison Engineer. Caltrans' staff may contact the appropriate Technical Committee Chair or Technical Specialist.

AASHTO-CA BDS-8 is available on the Caltrans' Division of Engineering Services website. If you are not able to locate AASHTO-CA BDS-8 or any other bridge manual, please contact us at: manuals.products@dot.ca.gov.

c: Thomas A. Ostrom, Acting Chief, Division of Engineering Services
Janice Benton, Chief, Division of Design
Sue Hida, Chief, DES SP&I Office of State Bridge Engineer Support
Nina Choy, Chief, DES SP&I Office of Structure Quality Management
Mark Mahan, Chief, DES SP&I Office of Earthquake Engineering
Joel Magaña, Chief, DES SP&I Office of Design & Technical Services
Offices of Bridge Design, DES SD
Sergio Aceves, Assistant Division Chief, Division of Pavements

Enclosure #7

Memorandum

To: SCOTT EADES
Director
District 5

Date: March 21, 2023

File: 0516000163
05-1H8001
01-MON-63

From: THOMAS A. OSTROM 
State Bridge Engineer
Chief
Division of Engineering Services

Subject: **GARRAPATA CREEK BRIDGE RAIL REPLACEMENT PROJECT**

This memorandum is in response to a question as to whether a design exception would be granted to allow for a larger clear opening in the bridge railings on Garrapata Creek Bridge. As set forth below, the Department of Transportation cannot construct bridge components that violate minimum safety standards set forth in federal and state law and policy, and as such, neither wider openings nor narrower railings than those proposed by the Department may be used in the Garrapata Creek Bridge Rail Replacement Project.

Bridges in the United States are designed in accordance with specifications published by the American Association of State Highway and Transportation Officials (AASHTO). These specifications include the AASHTO LRFD Bridge Design Specifications (AASHTO LRFD-BDS), which provide the **minimum standards** for highway bridge design according to the Code of Federal Regulations. Bridge rail designs must meet the requirements of AASHTO LRFD-BDS, Section 13, which specifies in part that the clear opening between elements shall be such that a 6-inch-diameter sphere shall not pass through the opening. Since this is a safety requirement, a design exception cannot be granted to increase the clear openings in the bridge railing: such exception would violate state and Federal standards and jeopardize public safety.

Additionally, all new permanent and replacement bridge railing on the State Highway System must comply with the Manual for Assessing Safety Hardware (MASH). There is no design exception process to grant a waiver for a bridge rail to not comply with MASH criteria. Attached is the MASH implementation memorandum that requires all bridge rails to be MASH compliant.

SCOTT EADES
March 21, 2023
Page 2

For questions regarding this memorandum, please contact Joel Magana, Chief, Office of Design and Technical Services, at (916) 952-4345.

Attachment

"Implementation of the Manual for Assessing Safety Hardware," dated December 23, 2016

c: Ruth Fernandes, Deputy Division Chief, Division of Engineering Services (DES)
Joel Magana, Chief, DES Office of Design & Technical Services (ODTS)
Greg Kaderabek, Technical Specialist, DES ODTS
Peter Hendrix, District Traffic Safety Engineer, Caltrans District 5
Kelly McClain, Chief, Maintenance Division, Caltrans District 5
Carla Yu, Project Manager, Senior Transportation Engineer, Caltrans District 5
Mitch Dallas, Senior Coastal Resources Specialist, Caltrans District 5

Enclosure #8

Memorandum

*Making Conservation
a California Way of Life*

To: STRUCTURE POLICY BOARD

Date: August 2, 2019

From: RUTH FERNANDES *RUF*
State Bridge Engineer (Acting)
Division of Engineering Services

Subject: **INTERIM TYPE SELECTION GUIDELINES FOR BRIDGE RAILINGS IN CALIFORNIA**

On December 22, 2015, the Federal Highway Administration (FHWA) and the American Association of State Highway and Transportation Officials (AASHTO) jointly released a memo approving a schedule for compliance with the Manual for Assessing Safety Hardware (MASH) for roadside safety hardware devices.

On December 23, 2016, Caltrans adopted an implementation schedule whereby bridge railings on projects on the State Highway System advertised on or after October 31, 2019, must comply with MASH criteria for all new permanent installations and full replacements.

Attachment 2 includes information on Caltrans' Division of Engineering Services (DES) MASH implementation plan for bridge railings revised July 2019.

Under MASH, the minimum height for bridge railings is increasing from 32 inches to 36 inches above the roadway for vehicular traffic railings for Test Level 4 locations. For Test Level 2 locations, the minimum railing height is increasing from 27 inches to 32 inches above the roadway for vehicular traffic railings and above the top of the walkway for combination railings.

The following type selection guidelines shown in the tables are recommended for projects with bridge railings in the planning and design phases. These guidelines will ensure adequate deck width and railing height during the transition to MASH approved systems.

Test Level 4 Locations (TL-4, speed greater than 45 mph):

Railing Type	Minimum Deck Width	Railing (MASH Compliant or Interim)	Avoid
Solid concrete parapet	1 foot-9 inches	MASH Compliant Concrete Barrier Type 836 (h = 36 inches) Concrete Barrier Type 842 (h = 42 inches)	Concrete Barrier Type 732, 736 & 742 (h = 32 inches, h = 36 inches, & h = 42 inches respectively)
Concrete parapet and metal rail	2 feet	Interim Concrete Barrier Type 90 (h=36 inches)	--
Post and Beam-steel	2 feet	Interim California ST-70 Bridge Rail (h = 46 ½ inches) California ST-20S Bridge Rail (h = 46 ½ inches) (bicycle h = 54 inches)	California ST-10 Bridge Rail (h=33 inches) California ST-30 Bridge Rail (h=32 inches)
Post and Beam-steel (side-mount)	N/A	MASH Compliant California ST-70SM Bridge Rail (h = 42 inches)	--
Post and Beam-concrete	2 feet	Interim Concrete Barrier Type 80 (h = 32 inches)	--

All Test Level 4 Rail systems listed above are adequate for Test Level 2 applications.

Railing Type	Minimum Deck Width	Railing (MASH Compliant or Interim)
Solid concrete parapet with sidewalk	1 foot plus 6 feet-2 inches minimum	MASH Compliant Concrete Barrier Type 732SW (h = 32 inches above sidewalk)
Post and Beam – concrete with sidewalk	2 feet plus 6 feet-2 inches minimum	Interim Concrete Barrier Type 80SW (h = 32 inches above sidewalk)
Post and Beam – steel with sidewalk	2 feet plus 6 feet-2 inches minimum	Interim California ST-40 Bridge Rail (h = 42 inches above sidewalk)

If a bridge rail currently under development is not available for use until after RTL but before Bid Opening, follow normal project addendum processes to revise the plans to include the new MASH-compliant bridge rail. If the bridge rail under development gets approved after Bid Opening, follow normal project change

STRUCTURE POLICY BOARD

August 2, 2019

Page 3

order processes to include the new MASH-compliant barrier on the project.

Please revise your internal business practices to include the Bridge Railing Specialists in the transmittal of Type Selection, General Plans. It's strongly recommended to get the Bridge Railing Specialists involved in bridge railing issues as early as possible in a project, and any time there is a change to the bridge railing type or a proposed bridge railing modification.

For questions, please contact Joel Magaña at (916) 227-8018 or by email <desdesign@dot.ca.gov>.

Attachments

1. "Implementation of the Manual for Assessing Safety Hardware" Memo, dated 12/23/2016
2. "MASH Implementation for California Bridge Railings" table, dated July 2019

c: Joel Magaña, Chief, Office of Design and Technical Services

Bridge Design Office Chiefs

Sudhakar Vatti, Chief, Office of Special Funded Projects/Structures Local Assistance

David Cordova, Office of Standards and Procedures, Division of Design

Tillat Satter, Bridge Railing Specialist, DES

Greg Kaderabek, Bridge Railing Specialist, DES

David Seifert, Structure Design Quality Management Representative

Memorandum

*Serious drought.
Help save water!*

To: CHIEF DEPUTY DIRECTOR
DEPUTY DIRECTORS
DISTRICT DIRECTORS
DIVISION CHIEFS

Date: December 23, 2016

From: *LH Orcutt*
STEVE TAKIGAWA
for Deputy Director
Maintenance and Operations
Karla Sutliff
for KARLA SUTLIFF
Chief Engineer
Project Delivery

Subject: **IMPLEMENTATION OF THE MANUAL FOR ASSESSING SAFETY HARDWARE**

This memorandum establishes California Department of Transportation's (Caltrans) timeline for implementation of roadside safety hardware and evaluation of new products under the Manual for Assessing Safety Hardware (MASH), consistent with the Association of State Highway and Transportation Officials (AASHTO) and Federal Highway Administration (FHWA) Joint Implementation Agreement for MASH.

As a matter of practice, FHWA performs a crash worthiness review of roadside safety hardware and when found crash worthy issues a federal aid eligibility letter. Caltrans uses this letter as part of its internal product review process. After December 31, 2016, the FHWA will no longer issue eligibility letters for highway safety hardware not successfully crash tested to MASH. Modifications of eligible highway safety hardware must utilize criteria in the MASH for re-evaluation and/or retesting. Manufacturers must submit new products complying with MASH to Caltrans for review and approval. Caltrans has previously adopted MASH for crash testing internal designs of safety hardware and through this implementation will use only those guidelines to evaluate new products.

Caltrans is adopting the AASHTO/FHWA recommendation to implement MASH for evaluating all new permanent installations and full replacements of roadside safety hardware. Below is the Caltrans implementation schedule of MASH for projects that will be advertised on or after the following dates:

- June 30, 2017: inline w-beam terminals (earlier than AASHTO/FHWA letting date)
- October 31, 2017: w-beam barriers and cast-in-place concrete barriers
 - The Midwest Guardrail System, approved on July 9, 2013, is the Caltrans standard for w-beam barriers and is MASH approved.
- April 30, 2018: Flared w-beam terminals
- October 31, 2018: cable barriers, cable barrier terminals, and crash cushions

- October 31, 2019: bridge rails, transitions, all other longitudinal barriers (including portable barriers installed permanently), all other terminals, sign supports, and all other breakaway hardware.

For temporary work zone roadside safety hardware, including portable barriers, devices manufactured after December 31, 2019, must have been successfully tested to MASH. Such devices manufactured by this date, and successfully tested to NCHRP Report 350, may continue to be used throughout their normal service lives.

After December 31, 2016, Caltrans will no longer evaluate highway safety hardware that has not been successfully crash tested to MASH. Modifications of federal aid eligible highway safety hardware must utilize criteria in MASH for re-evaluating and/or retesting.

Implementation will include these actions:

- Projects on the State highway system with an advertising date on or after the above implementation schedule must use safety hardware that complies with the MASH criteria for all new permanent installations and full replacements.
- New products compliant with MASH must be submitted to the Caltrans New Products Coordinator. Then the Caltrans' Highway Safety Features New Products Committee will evaluate and make recommendations for approval of the new products.

The MASH approved safety hardware devices for Caltrans can be found at:
<http://traffic.onramp.dot.ca.gov/safety-devices-approved-products>

For questions regarding this process for highway safety features, please contact Duper Tong, Chief, Office of Traffic Engineering at (916) 654-5176 or by email at duper.tong@dot.ca.gov; or for bridge rails, transitions, sign supports and other breakaway hardware, Shannon Post, Chief, Office of Design and Technical Services at (916) 227-8070 or by email at shannon.post@dot.ca.gov.

- c: Thomas P. Hallenbeck, Chief, Division of Traffic Operations
Tony Tavares, Chief, Division of Maintenance
Rachel Falsetti, Chief, Division of Construction
Janice Benton, Acting Chief, Division of Design
Michael Keever, Chief, Division of Engineering Services
Jim Appleton, Chief, Division of Research, Innovation and System Information