

Exhibit D

This page intentionally left blank.

DRAFT
02-01-2024

Design Guidelines for a New Community

East Garrison Pattern Book



*Design Guidelines for a
New Community*

East Garrison Pattern Book

JULY 2004

XX JANUARY 2024

*Design Guidelines for a
New Community*

Master Developer

EAST GARRISON PARTNERS I, LLC

Master Code Consultant

URBAN DESIGN ASSOCIATES

Pittsburgh, Pennsylvania

Landscape Architects

LAQUATRA BONCI

ASSOCIATES

Pittsburgh, Pennsylvania

SECTION **A** Introduction

- A-1 Overview
- A-3 The Townscape of East Garrison
- A-4 How To Use This Pattern Book
- A-5 Houses on Lots

SECTION **B** Community Patterns

- B-1 Overview
- B-2 Lot Types
- B-3 Setback Requirements
- B-4 Townhouse Lots
- B-5 Live/Work Townhouse [Rowhouse](#) Lots
- [B-6 Hamlet Lots](#)
- B-7 Grove Lots
- B-8 Garden Lots
- B-9 Bungalow Lots
- B-10 Village Lots
- B-11 Courtyard Lots
- B-12 Bluff Lots
- B-13 Carriage Houses
- B-14 Court Apartments/Townhomes – Site A
- B-15 Court Apartments/Townhomes – Site B
- B-16 Garrison Town Center
- B-17 Contributing Historic Buildings
- B-18 Wood Buildings
- B-19 Summary of Lot Specifications

SECTION **C** Architectural Patterns

- C-1 Architectural Patterns
 - GARRISON CRAFTSMAN
- C-2 History and Character
- C-3 Massing and Composition
- C-4 Massing and Eave Details
- C-5 Windows and Doors
- C-6 Porches
- C-7 Materials, Colors, and Possibilities
 - PICTURESQUE CAMP
- C-8 History and Character
- C-9 Massing and Composition
- C-10 Massing and Eave Details
- C-11 Windows and Doors
- C-12 Porches
- C-13 Materials, Colors, and Possibilities
 - MEDITERRANEAN REVIVAL
- C-14 History and Character
- C-15 Massing and Composition
- C-16 Massing and Eave Details
- C-17 Windows and Doors
- C-18 Porches
- C-19 Materials, Colors, and Possibilities
 - GARRISON REVIVAL
- C-20 History and Character
- C-21 Massing and Composition
- C-22 Massing and Eave Details
- C-23 Windows and Doors
- C-24 Porches
- C-25 Materials, Colors, and Possibilities

TOWN CENTER

- C-26 Character
- [C-27 Town Center Architecture](#)
- [C-28 Town Center Town Center Architecture](#)
- [C-29 Conceptual Building Elements](#)
- [C-30 Building Tenant Identification](#)

COMMUNITY FACILITIES

- C-31 Character
- C-32 Materials, Colors, and Possibilities
- C-33 Building Identification and Wayfinding

ARTISTS LOFTS

- ~~C-36 Character~~
- ~~C-37 Regulating System~~
- ~~C-38 Composition~~
- ~~C-40 Materials, Colors, and Possibilities~~
- ~~C-41 Building Tenant Identification~~

[LIVE / WORK ROWHOUSES](#)

- [C-34 Character](#)
- [C-35 Facade Kit-of-Parts](#)
- [C-36 Live/Work Rowhouses Mediterranean Revival](#)
- [C-37 Live/Work Rowhouses Craftsman](#)
- [C-38 Live/Work Rowhouses Storefronts](#)

SECTION **D** Landscape Patterns

- D-1 Landscape Patterns for Individual Lots
- D-2 Front Yard Landscapes
- D-3 Front Yard Landscape Styles
- D-4 Landscape Patterns – Mediterranean Landscapes
- D-5 Landscape Patterns – Cottage Landscapes
- D-6 Landscape Patterns – Arts & Crafts Landscapes
- D-7 Landscape Patterns – Shared Courtyard Elements
- D-8 Landscape Patterns – Lane Elements
- D-9 Permitted Upgrades - Front Yard Fences & Walls
- D-10 Rear/Side Yard Fences & Screens
- D-11 Permitted Fence Locations
- D-12 Permitted Upgrades – Paving Surfaces
- D-13 Lot Landscape Palette (Non-Irrigated)
- D-14 Lot Landscape Palette (Irrigated)

SECTION **E** Appendix

GUIDELINES FOR REHABILITATING
BUILDINGS AT EAST GARRISON

- E-1 Overview
- E-2 Wood
- E-7 Windows
- E-12 Entrances & Porches
- E-15 Additions

The East Garrison Pattern Book (EGPB) illustrates and defines the basic parameters of all private development in East Garrison—from the scale of the commercial uses to the scale of the community. The EGPB defines appropriate architectural styles as well as traditional zoning criteria for height, setbacks, and parking. Upon adoption of the East Garrison Specific Plan, the EGPB will establish the development standards and land use designations. It will become part of the administrative document governing East Garrison.



Aerial view of the East Garrison as it exists today on the former Fort Ord



East Garrison today



Picturesque Camp precedent



Mediterranean Revival precedent

Courtesy of JBZ Architecture + Planning



Garrison Craftsman precedent



Native plant species in the Bluff Park



Landscape precedent



Garrison Craftsman windows

FOR ALMOST 200 YEARS, pattern books have been used throughout the United States as a reference for builders and homeowners in building houses, churches, civic buildings, and garden structures, often in remote locations without the aid of an architect. The East Garrison Pattern Book (EGPB) has drawn on this technique to create a design palette for the new community.

This Pattern Book presents a vision for East Garrison and serves as a general guide to the development of the community, establishing **minimum standards** that address the intended neighborhood character, building design, and landscape elements. The design guidelines contained in the East Garrison Pattern Book are based on extensive research and documentation by the development team of regional precedents in Monterey County and the Central Valley – particularly those in Spreckels and Salinas. Drawing on these precedents, the design principles for the new community of East Garrison are aimed at creating a full spectrum of attractive housing opportunities in a manner that respects the qualities of the local landscape.

The East Garrison Pattern Book contains four sections: this *Introduction*; the *Community Patterns* section which sets standards for how buildings are sited on the various lot types; the *Architectural Patterns* section which establishes design guidelines for the prescribed architectural styles; and the *Landscape Patterns* section which provides guidelines for individual landscaping on lots.

The *Community Patterns* guidelines serve to ensure that neighborhoods contain a range of house sizes. Sidewalks and bike lanes in the development will make the community pedestrian- and bike-friendly. Parks provide neighborhood-based active and passive recreational amenities for residents.

Overview



Precedent for converting an historic building into artist space



Inviting character of Town Center public space



Town Square precedent



Hollister mural illustrating downtown civic amenities

Four architectural styles have been selected for East Garrison: Garrison Craftsman, Picturesque Camp, Mediterranean Revival, and Garrison Revival. The *Architectural Patterns* section provides information regarding each of these styles, including a description of the history and character of the particular style as well as its basic massing and composition.

Guidelines are also included regarding massing, eave details, windows, doors, porches, materials, and colors along with illustrations of just a few of the possibilities. This kit of parts affords architects, builders, and homebuyers examples for personalizing a new home in East Garrison.

The Plan includes a Town Center and an Arts District. The Town Center will draw on the character and quality of regional precedents and accommodate a mix of uses including housing, civic uses, and commercial ventures. A town green will serve as a focal point for the community. Buildings with ground-floor shops and offices will line the main commercial streets. Apartments and offices above will create a mixed-use environment reminiscent of the charming and beloved main street of traditional towns. The Arts District will provide live/work studio spaces for artists in the region. The pavilion design of these three-story buildings reflects the simple, repetitive character of the Fort Ord warehouses nearby, providing artists with modest-cost housing.

The East Garrison community will be situated in surroundings that include maritime chaparral and extensive stands of coastal live oak woodlands. The development plan is designed to preserve these habitats outside the core settlement area. The community has been designed in a compact form to create a distinct natural edge.

For individual lot landscaping, the *Landscape Patterns* section includes standard hardscape materials as well as permitted upgrades and a plant material palette that emphasizes the use of native species.

This Pattern Book is part of the East Garrison Specific Plan and will serve as the basis for design review and implementation.

Overview



Grove lot houses line intimate streets.



Artist lofts in the Arts District Mixed-use building in the Town Center



Many houses line neighborhood parks located throughout each district.



The Town Center will have a green lined with shops, offices, and housing.

East Garrison Tomorrow

EAST GARRISON IS DESIGNED IN THE tradition of historic American settlements. The community will have a mix of different uses and a fine-grained network of streets, blocks, parks, and open spaces surrounded by over 20,000 acres of preserved natural habitat.

Close by are California State University at Monterey Bay and University of California Monterey Bay Education Science Technology Center. Access to jobs and regional institutions will be a major component of East Garrison. The new community will provide a full spectrum of housing opportunities for all segments of the Monterey County market.

The neighborhoods in East Garrison will each have a distinct character related to their location on the site. Native plants and landscape elements will add to the distinctive character as will the design of the houses and buildings within the town. The essential qualities of these neighborhoods will reflect the vernacular architecture of established communities in the region, such as Salinas and Spreckels. These communities have a variety of different house types and styles, pedestrian-friendly streets, and unique park spaces.

A significant element in the new community is the Phase 3 Arts District which will feature an extensive array of working artists studios, performance spaces, and live/work studios in both historic and new buildings.

The Townscape of East Garrison

How To Use This Pattern Book

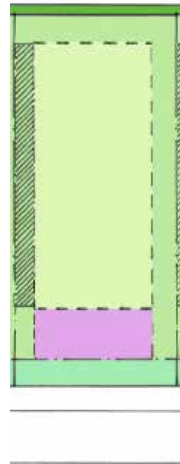

A typical Grove lot diagram

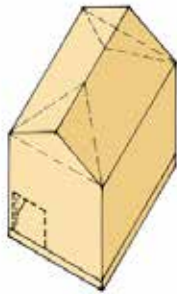

Illustrative main body massing

The East Garrison Pattern Book will guide the development of the community. Three key aspects of house and lot design are addressed:

- *Community Patterns* define the lotting patterns for the neighborhoods;
- *Architectural Patterns* establish the four architectural styles for the community, illustrate neighborhood character, and define the standard elements; and
- *Landscape Patterns* set the plant palettes and minimum landscape standards for the community.

The Pattern Book is designed to be used in the following six-step process.

Step 1 Select the lot type.

Match the lot dimensions to the lot type descriptions in the *Community Patterns* section. The lot descriptions include the required minimum setbacks for the front, side, and rear yards for each lot type.

Step 2 Identify the shape and size of the house.

The example on page A5 depicts the typical massing pieces for houses in East Garrison: the main body, the porch, side or rear wings, and outbuildings. The basic mass of the house will determine the general location of the programmatic elements. Each architectural style – Garrison Revival, Picturesque Camp, Garrison Craftsman, and Mediterranean Revival (refer to the *Architectural Patterns* section) – has its own page that describes the basic massing types for that style based on regional precedents. The roof types are part of this overall massing decision.



A sample California House plan



Illustrative window and door placement diagram

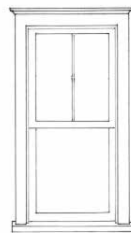

Illustrative window elevation

Step 3 Select the window and door style/details.

One page of typical window and door compositions for each of the four architectural styles for East Garrison is provided in the *Architectural Patterns* section. The drawings include typical window and door proportions, trim details, and special window or door elements. Window and door spacing is related to both the shape and the style of the house. These elements must be taken into consideration when designing the house elevations.

Step 4 Make a decision about porches.

Porches are important to the character of each house. The massing of the front porch is specific to the house type and varies from one architectural style to another. The suggested location and design elements of porches on East Garrison houses can be found on the designated page within each style in the *Architectural Patterns* section.

Step 5 Consider the design possibilities and choose appropriate materials.

Elevation drawings composed using elements described in the pattern book can be found on the last page of each style in the *Architectural Patterns* section. These elevations illustrate a sampling of the multiple design possibilities that can be achieved using the pattern book. These pages also provide a list of acceptable materials from which to choose.



Illustrative porch elevation

Step 6 Enhance the house with attention to the landscaping.

Refer to the *Landscape Patterns* section for guidance regarding the selection of landscape elements including fences, walls, paving materials, and appropriate plant types.



Illustrative garden landscaping



Illustrative house elevations

How To Use This Pattern Book



An East Garrison House
Simple, dignified massing with porches and rear wings added.

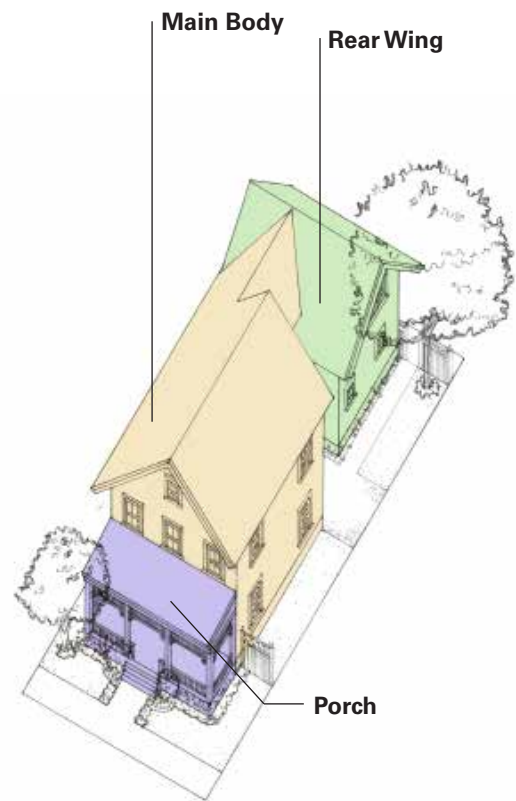

Elements of the East Garrison House
The Main Body is the largest and most visible element with the most specific design requirements. Side or rear wings, porches, and outbuildings provide a menu of options for the homebuilder.

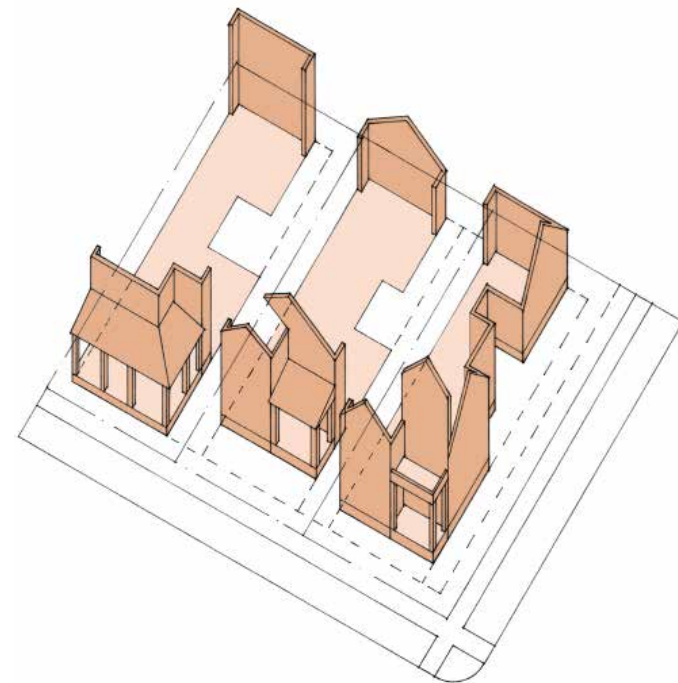

Key Facades of the East Garrison House
The principle elevations of the East Garrison house are facades facing streets and lanes. These are the only facades that require full-wrap architecture.

Illustrative Main Body Massing Types

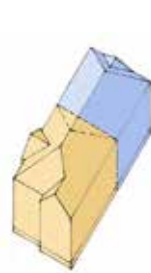

Gable L with Hip Roof House

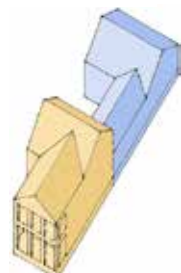

Front Gable House

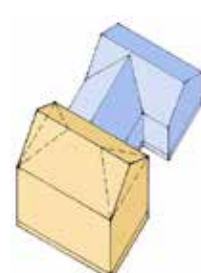

Side Gable House

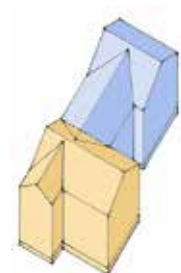

Gable L House

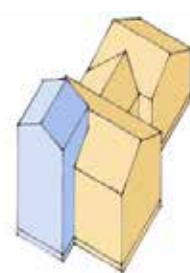

Side Gable House with Tower



Illustrative street scene

Houses on Lots

Key Components of the House

EAST GARRISON HOUSES WILL CREATE the backdrop for each neighborhood. The houses will define the character of the space and reflect the individual composition of the private realm behind the porch or front door.

In these traditional neighborhoods, the front portion of the house is the most public and must be responsive to the character of the neighborhood and the adjacent houses. The landscaping of the front yard, the setbacks from the street, the size and placement of the house on the lot, and the front porch are all shared elements that form the public realm.

The houses in East Garrison are based on the vernacular architecture of Monterey County, using regional house types with style elements applied. The house types are defined by the character and shape of the Main Body and Wings that are added to increase the internal space.

The patterns described in this book apply primarily to facades facing streets and lanes. Full-wrap architecture (the use of a single material and consistent style and trim elements on all facades) is required on all elevations except those facing a neighboring house on an adjoining property (see the Key Facades illustration at left). The material transition point should be a minimum of three feet back from the corner of the house.

Principal Elements

East Garrison houses include the following principal elements:

The **Main Body** of the house, which is the principal mass and includes the front door.

Side or Rear Wings, which are one or two stories high and connected to the Main Body. These optional additions are smaller than the Main Body and are set back from the front facade.

Porches create exterior living space. Possibilities include full-facade front

porches, wraparound porches, porticos, and side porches. Some architectural styles also have inset porches.

Outbuildings are optional structures that include carports, detached garages, storage buildings, and carriage houses.

Towers and Cupolas are optional design elements.

Lot Types

EAST GARRISON OFFERS A VARIETY of lot types and locations ranging from 28 feet to approximately 65 feet wide. These lot types include Townhouse, Corner, Garden, Backlot, Village, Compound, and Bluff Lots. Most of these lots have one lane access parking - either a garage, carport, or porch parking pad - with continuous front yard landscaping interrupted by parked cars and driveways. Lot types are noted throughout the community. In addition to the single family lots, multi-family lots and buildings have been integrated into the neighborhood. Following the description of setback requirements for the neighborhood, general conditions for each of the lot types are presented.

Note: Public sewer collection is not shown on this plan as it is not required within a 1/2 mile radius of the site.

Lot Types

COMMUNITY PATTERNS

Community Patterns Overview

THE COMMUNITY PATTERNS SECTION contains specific requirements for placing houses and buildings on specific sites within the plan. These guidelines were developed as part of the master planning process and are meant to ensure that the diversity and character of East Garrison called for in the East Garrison Specific Plan are implemented and maintained.

All housing designs and site plans must be reviewed and approved via the East Garrison Design Review process set forth in the East Garrison Specific Plan, Section 6.2 Design Review.

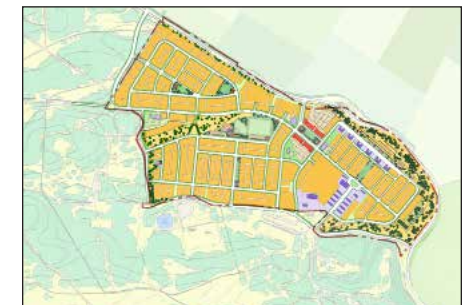
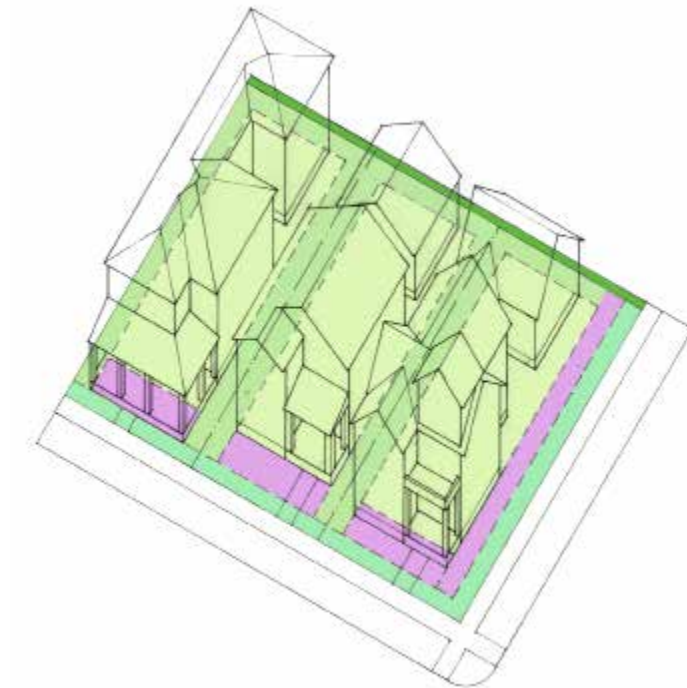

Overview

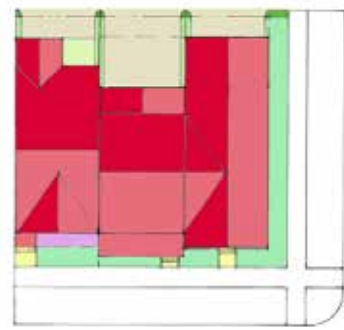

Townhouse Lots

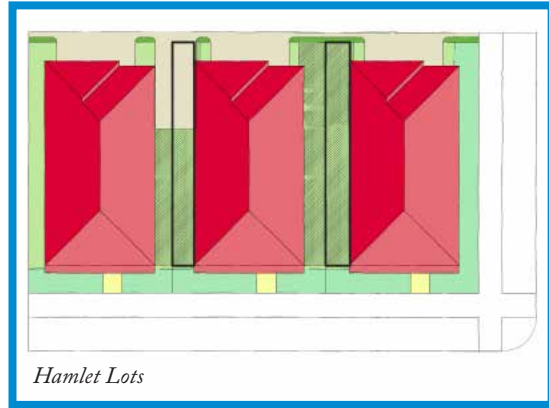

Hamlet Lots

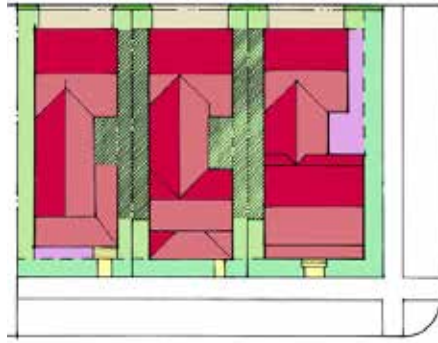

Grove Lots

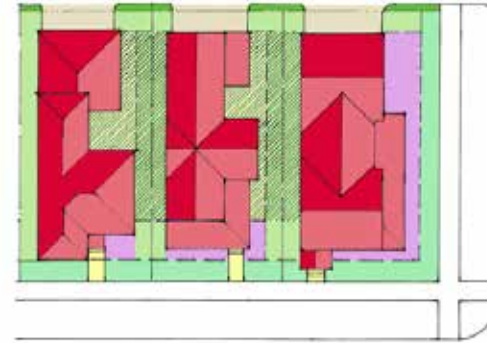

Garden Lots

Note: Public areas adjacent to lots (shown in white on all lot types) may or may not contain a park strip between the sidewalk and the curb.

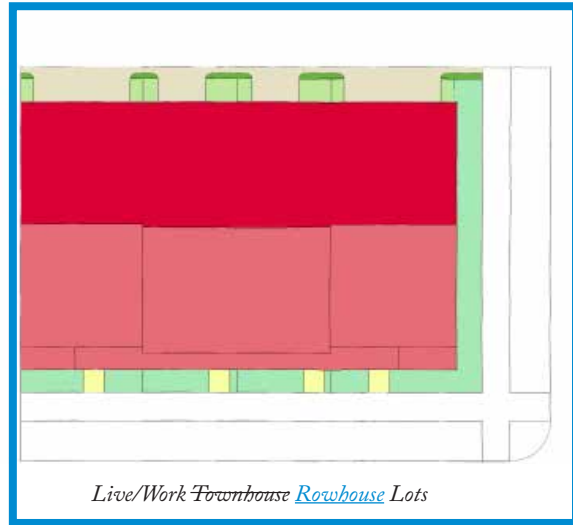

Live/Work Townhouse Rowhouse Lots

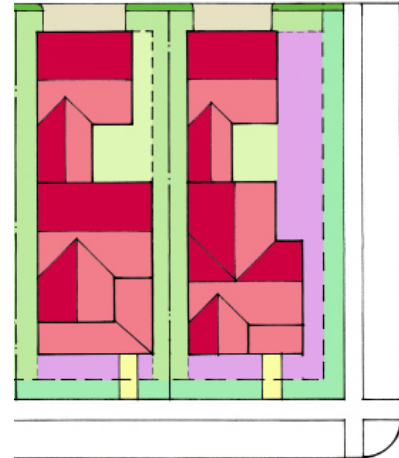

Bungalow Lots

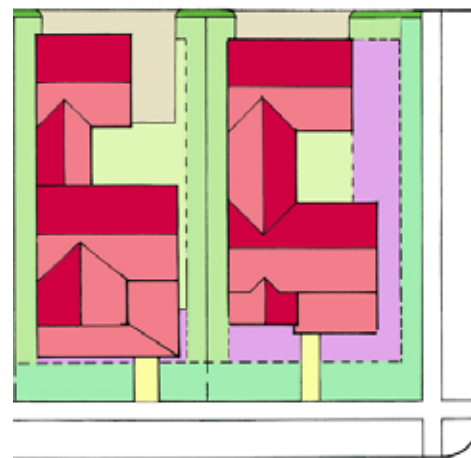

Village Lots

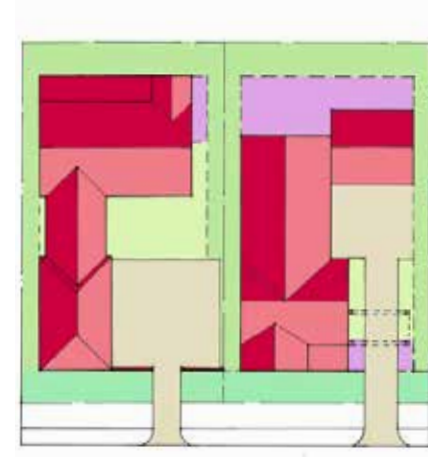

Bluff Lots

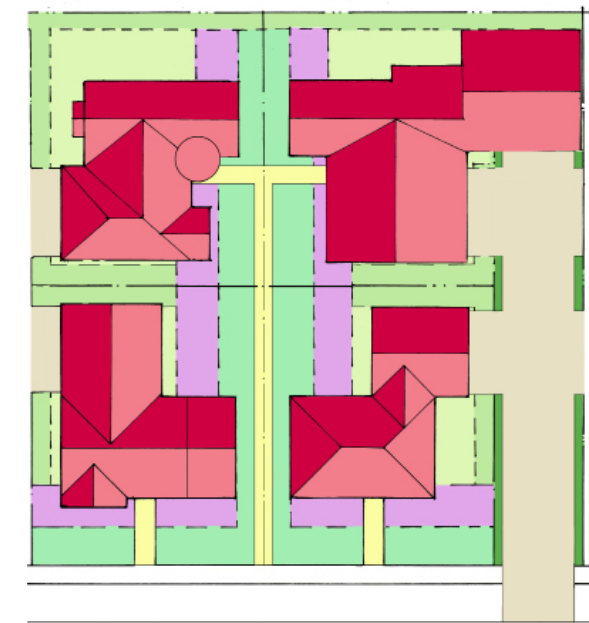

Courtyard Lots

Lot Types

EAST GARRISON OFFERS A VARIETY of lot types and locations ranging from 18 feet to approximately 65 feet wide. These lot types include Townhouse, Grove, Garden, Bungalow, Village, Courtyard, and Bluff Lots. Most of these lots have rear lane accessed parking – either a garage, carport, or paved parking pad – with continuous front yard landscaping uninterrupted by parked cars and driveways. Lot types are mixed throughout the community. In addition to the single-family lots, multi-family sites and buildings have been integrated into the neighborhoods. Following the description of setback requirements (on the next page), general conditions for each of the lot types are presented.

Lot Types



Illustrative setback plan

Setback Requirements

The **Private Zone** is the buildable portion of the lot excluding the required setbacks and the Front and Side Street Facade Zones.

Each lot has a series of setback lines that define a minimum yard between houses, streets, and rear lanes. There are also zones within which the house shall be placed. The **Front Facade** (the front elevation of the house, including the porch or bays, which face the street or paseo on which the house has its address) shall be placed within the **Front Facade Zone** described in the general conditions for each lot type. The Front Facade Zone is generally the shorter dimension of the lot versus the side which is generally oriented along the longer property line. The Front Facade Zone is set back from the front property line at a distance defined by the **Front Yard Setback Line**. The **Front Yard**

Setback Zone is the area between the Front Yard Setback Line and the front property line. Porches and bay windows generally can project into the Front Yard Setback Zone.

On corner lots, a **Side Street Setback Zone** is established adjacent to the cross street. Its dimension is established in the *Community Patterns* and is measured from the side street right-of-way to the **Side Street Setback Line**. The primary side elevation shall be placed within the **Side Street Facade Zone**, which is described in the general conditions for each lot type.

The **Rear Yard Setback Zone** defines the minimum distance from the rear property line to the **Rear Yard Setback Line**. The Rear Yard Setback Line establishes a minimum setback for garages and side wings.



The street-facing facades of East Garrison houses will be placed in the Front and Side Street Facade Zones as shown above and throughout the Community Patterns section.

Setback Requirements

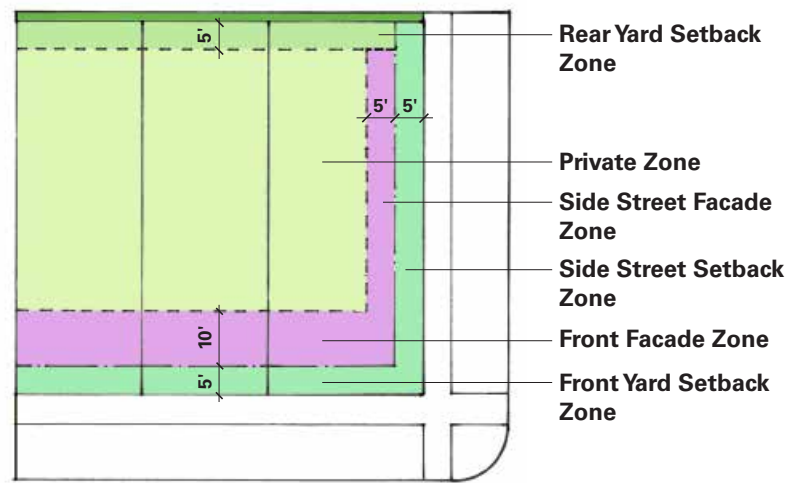

Plan of townhouse zones and setbacks



Illustrative plan of townhouse placement on the lot

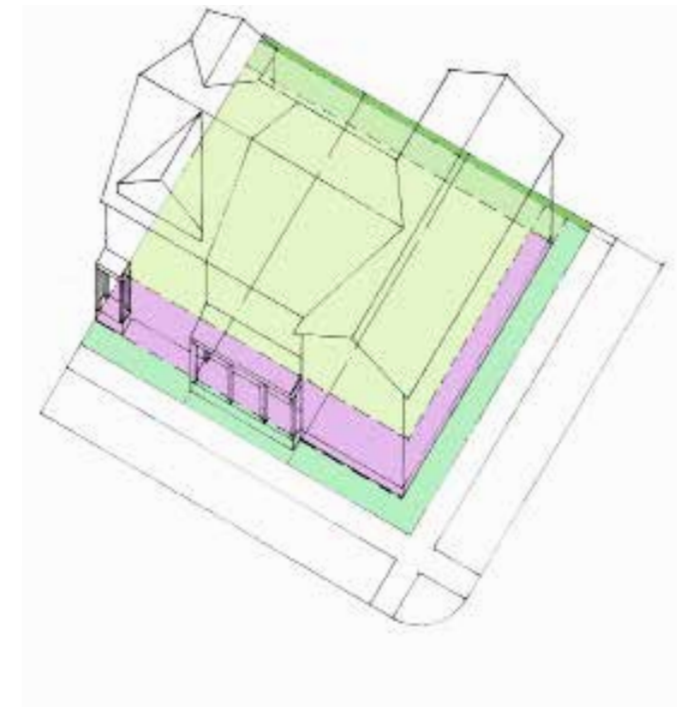

Townhouse Lots – General Conditions

Lot Size

Attached Live/Work Rowhouse lots range from approximately 16 to 30 feet wide by approximately 55 feet deep.

Front Yard Setback/ Front Facade Zone

Minimum five-foot setback from the front property line to the house. The front facade of the house may be located anywhere within the adjacent ten-foot-deep Front Facade Zone.

Side Yard Setback

Since the houses are attached, there is no required side yard setback. See Side Street Setback requirements for regulations concerning corner units.

Side Street Setback/ Side Street Facade Zone

A minimum five-foot setback from the side street property line to the house. The side street facade may be located anywhere within the adjacent five-foot-deep Side Street Facade Zone.

Rear Yard Setback

All structures shall be set back a minimum of five feet from the rear property line.

Encroachments

Porches and bay windows may encroach up to two feet into both the Front Yard and Side Street Setback Zones.

Garage Requirements

Garages shall be set back a minimum of five feet as required under Rear Yard Setbacks. If the design includes a parking pad, garages shall be set back a minimum of 18 feet from the rear lane right-of-way. Although covered parking is not required, a minimum of two parking spaces per unit is required.

Fencing Recommendations

Fences are not permitted.

Townhouse Lots





Plan of live/work rowhouse zones and setbacks

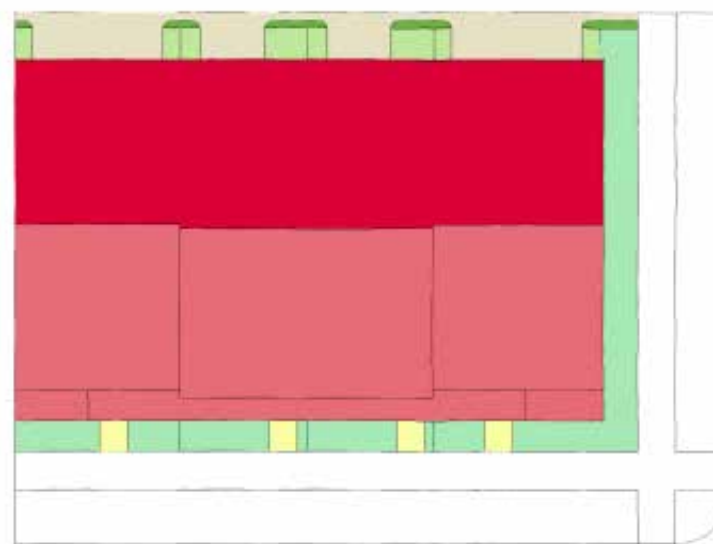

Illustrative plan of live/work rowhouse placement on the lot

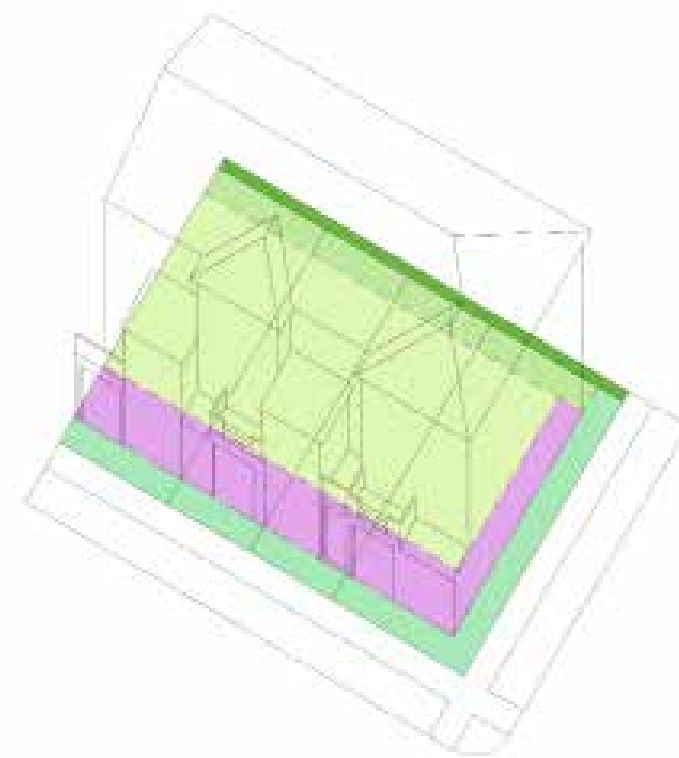

Live/Work Rowhouse Lots – General Conditions

Lot Size

Attached Rowhouse lots range from approximately 16 to 30 feet wide by a minimum of 55 feet deep.

Front Yard Setback/ Front Facade Zone

Minimum five-foot setback from the front property line to the house. The front facade of the house may be located anywhere within the adjacent ten-foot-deep Front Facade Zone.

Side Yard Setback

Since the houses are attached, there is no required side yard setback. See Side Street Setback requirements for regulations concerning corner units.

Side Street Setback/ Side Street Facade Zone

A minimum five-foot setback from the side street property line to the house. The side street facade may be located anywhere within the adjacent five-foot-deep Side Street Facade Zone.

Rear Yard Setback

All structures shall be set back a minimum of five feet from the rear property line.

Encroachments

Porches and bay windows may encroach up to two feet into both the Front Yard and Side Street Setback Zones.

Garage Requirements

Garages shall be set back a minimum of five feet as required under Rear Yard Setbacks. If the design includes a parking pad, garages shall be set back a minimum of 18 feet from the rear lane right-of-way. Although covered parking is not required, a minimum of two parking spaces per unit is required.

Fencing Recommendations

Front yard fences are a permitted upgrade. For additional fencing guidelines, see the Landscape Patterns section of this Pattern Book.

Live/Work Rowhouse Lots



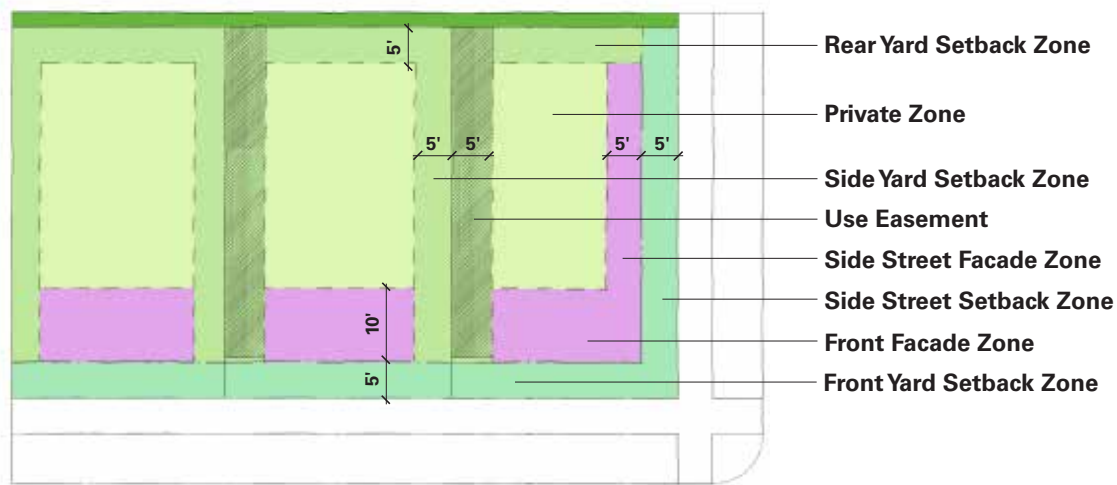

Plan of Hamlet zones and setbacks

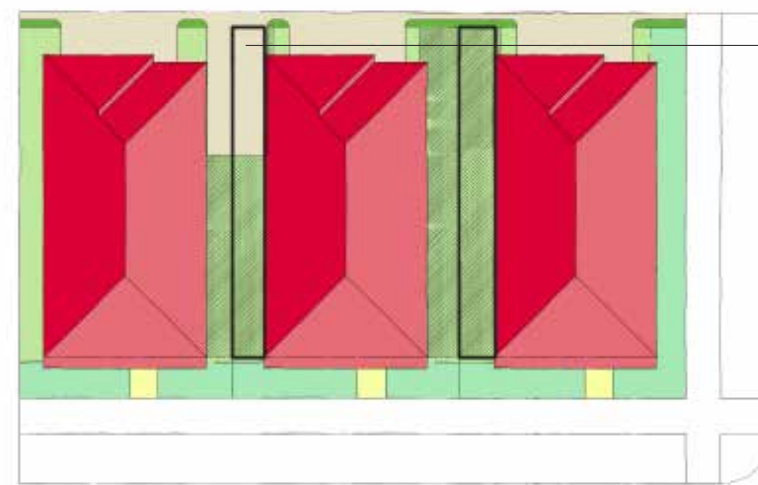

Illustrative plan of live/work townhouse *Hamlet* placement on the lot

Optional Parking Pad

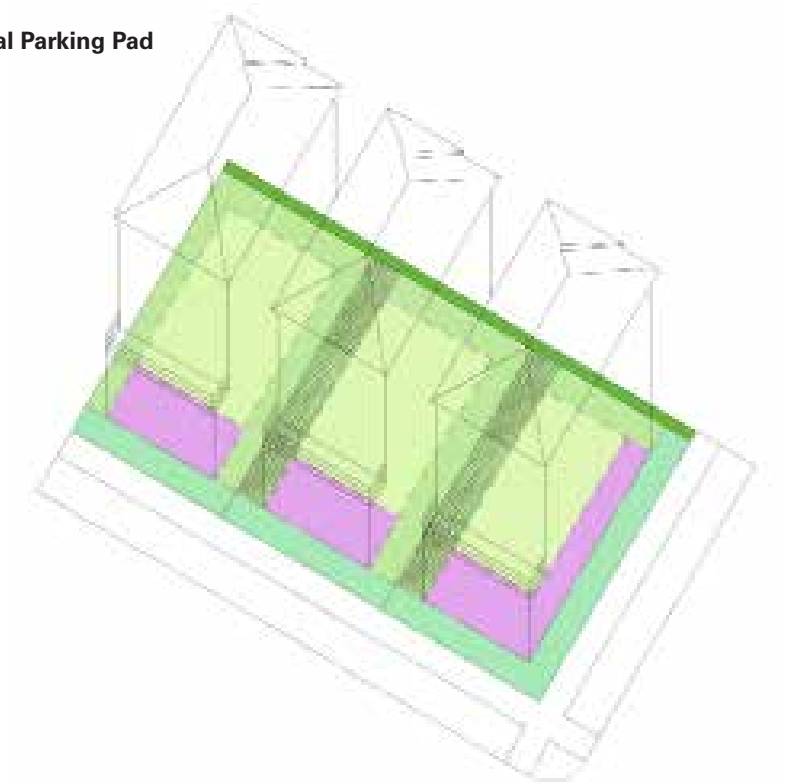

Hamlet Lots – General Conditions

Lot Size

Hamlet lots are approximately 30 to 40 feet wide by a minimum of 55 feet deep. Corner lots are approximately 35 feet wide.

Front Yard Setback/ Front Facade Zone

Minimum five-foot setback from the front property line to the house. The front facade of the house may be located anywhere within the adjacent ten-foot-deep Front Facade Zone. A minimum of 65% of the front facade shall be within the Front Facade Zone.

Side Yard Setback

Minimum four-foot setback from the side property line.

Use Easement

Hamlet houses are designed to be side-yard houses where private open space occurs between units. A side yard use easement shall be used to create functional outdoor space (shown hatched). The easement shall begin at the rear of the Front Facade Zone. Only ground floor clerestory windows are permitted facing neighbors' outdoor space/easement.

Side Street Setback/ Side Street Facade Zone

Minimum five-foot setback from the side street property line to the house. The side street facade may be located anywhere within the adjacent ten-foot-deep Side Street Facade Zone. A minimum of 30% of the side street facade shall be within the Side Street Facade Zone.

Rear Yard Setback

All structures shall be set back a minimum of five feet from the rear property line.

Encroachments

Porches and bay windows may encroach up to two feet into both the Front Yard and Side Street Setback Zones.

Fencing Recommendations

Front yard fences are a permitted upgrade. For additional fencing guidelines, see the Landscape Patterns section of this Pattern Book.

Parking

A minimum of two parking spaces per unit are required. Parking shall be covered.

Hamlet Lots



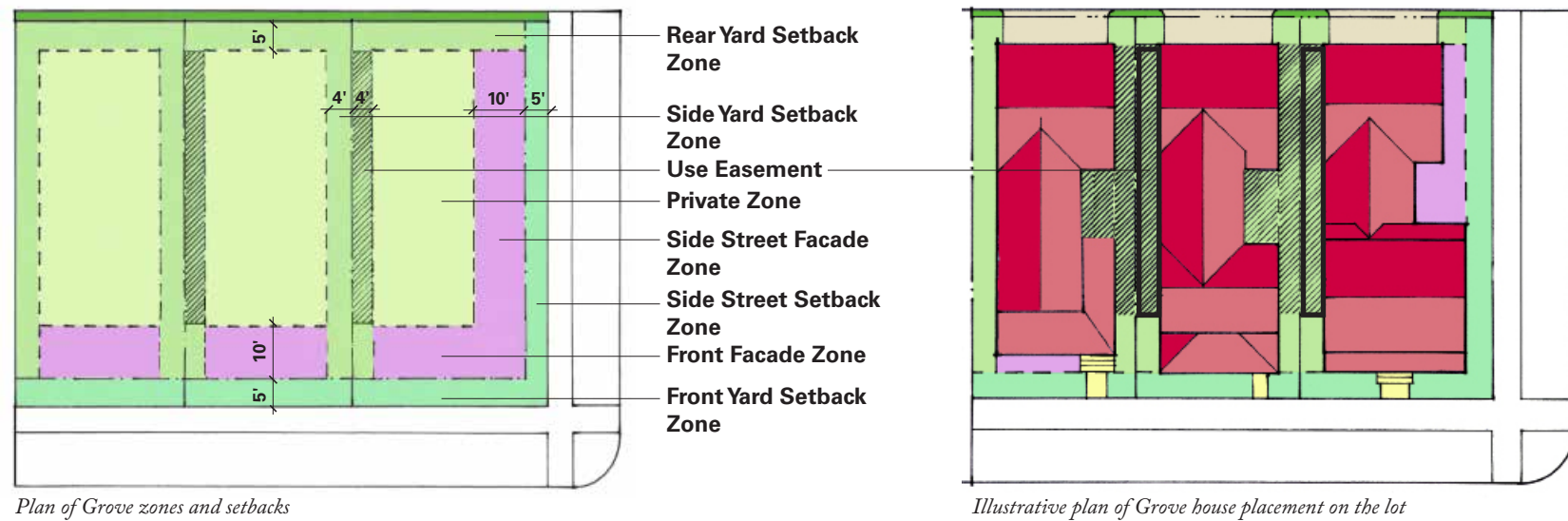

Plan of Grove zones and setbacks

Illustrative plan of Grove house placement on the lot

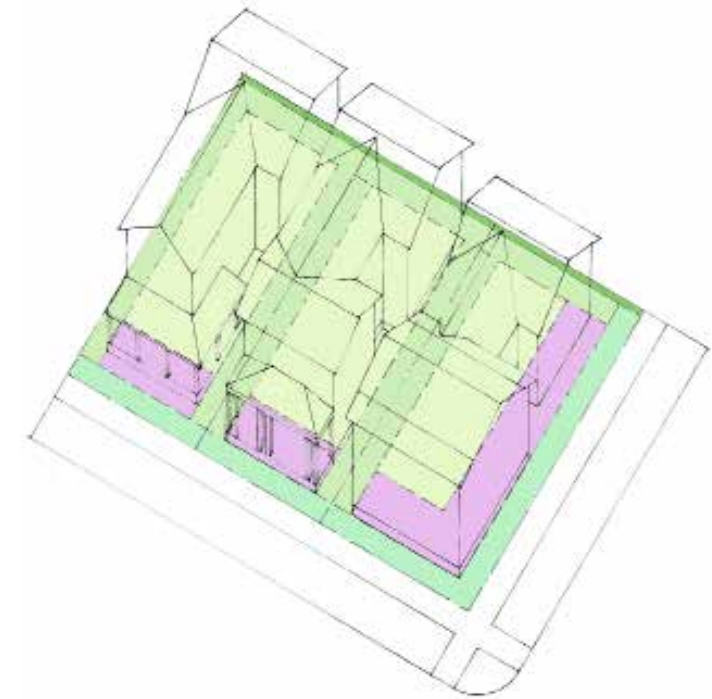

Grove Lots – General Conditions

Lot Size

Grove lots are approximately 30 feet wide by a minimum of 70 feet deep. Corner lots are approximately 35 feet wide.

Front Yard Setback/ Front Facade Zone

Minimum five-foot setback from the front property line to the house. The front facade of the house may be located anywhere within the adjacent ten-foot-deep Front Facade Zone. A minimum of 65% of the front facade shall be within the Front Facade Zone.

Side Yard Setback

Minimum four-foot setback from the side property line.

Use Easement

Grove houses are designed to be side-yard houses where private open space occurs between units. A side yard use easement shall be used to create functional outdoor space (shown hatched). The easement shall begin at the rear of the Front Facade Zone. Only ground floor clerestory windows are permitted facing neighbors' outdoor space/easement.

Side Street Setback/ Side Street Facade Zone

Minimum five-foot setback from the side street property line to the house. The side street facade may be located anywhere within the adjacent ten-foot-deep Side Street Facade Zone. A minimum of 30% of the side street facade shall be within the Side Street Facade Zone.

Rear Yard Setback

All structures shall be set back a minimum of five feet from the rear property line.

Encroachments

Porches and bay windows may encroach up to two feet into both the Front Yard and Side Street Setback Zones.

Fencing Recommendations

Front yard fences are a permitted upgrade. Rear yard fences are required for privacy. For additional fencing guidelines, see the Landscape Patterns section of this Pattern Book.

Open Space Requirement

Eight percent of the buildable lot area (Private, Front Facade, and Side Street Facade Zones) shall be maintained as open space.

Parking

A minimum of two parking spaces per unit is required. Parking shall be covered.

Living Area Limit

The maximum living area limit for Grove Lots is 2060 square feet.

Grove Lots



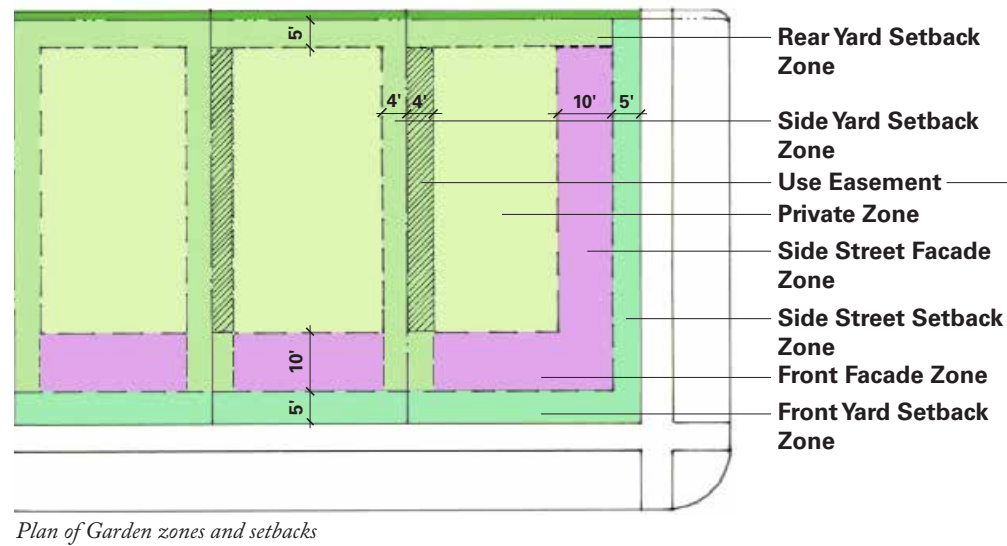

Plan of Garden zones and setbacks

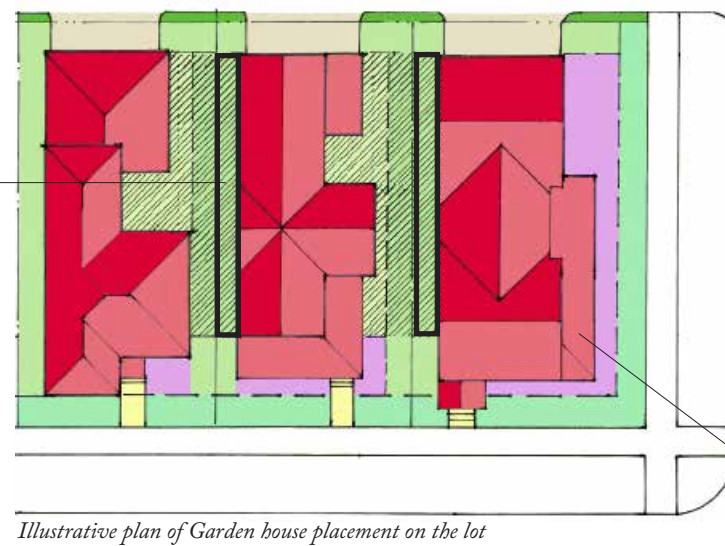

Illustrative plan of Garden house placement on the lot

Side or Wrap Around Porches Encouraged on Corner Lots

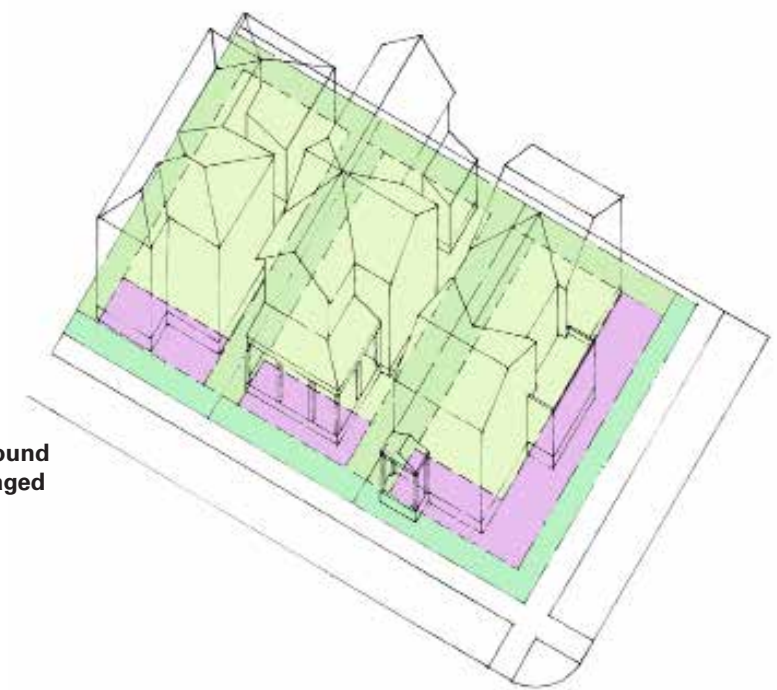

Garden Lots – General Conditions

Lot Size

Garden lots are approximately 35 feet wide by a minimum of 70 feet deep. Corner lots are approximately 40 feet wide.

Front Yard Setback/ Front Facade Zone

Minimum five-foot setback from the front property line to the house. The front facade of the house may be located anywhere within the adjacent ten-foot-deep Front Facade Zone. A minimum of 65% of the front facade shall be within the Front Facade Zone.

Side Yard Setback

Minimum four-foot setback from the side property line.

Use Easement

Garden houses are designed to be side-yard houses where private open space occurs between units. A side yard use easement shall be used to create functional outdoor space (shown hatched). The easement shall begin at the rear of the Front Facade Zone. Only ground floor clerestory windows are permitted facing neighbors' outdoor space/easement.

Side Street Setback/ Side Street Facade Zone

Minimum five-foot setback from the side street property line to the house. The side street facade may be located anywhere within the adjacent ten-foot-deep Side Street Facade Zone. Garage doors must face the rear lane right-of-way. A minimum of 30% of the side street facade shall be within the Side Street Facade Zone.

Rear Yard Setback

All structures shall be set back a minimum of five feet from the rear property line.

Encroachments

Porches and bay windows may encroach up to two feet into both the Front Yard and Side Street Setback Zones.

Fencing Recommendations

Front yard fences are a permitted upgrade. Rear yard fences are required for privacy. For additional fencing guidelines, see the Landscape Patterns section of this Pattern Book.

Open Space Requirement

Ten percent of the buildable lot area (Private, Front Facade, and Side Street Facade Zones) shall be maintained as open space.

Parking

A minimum of two parking spaces per unit is required. Parking shall be covered.

Living Area Limit

The maximum living area limit for Gardens Lots is 2420 square feet.

Garden Lots



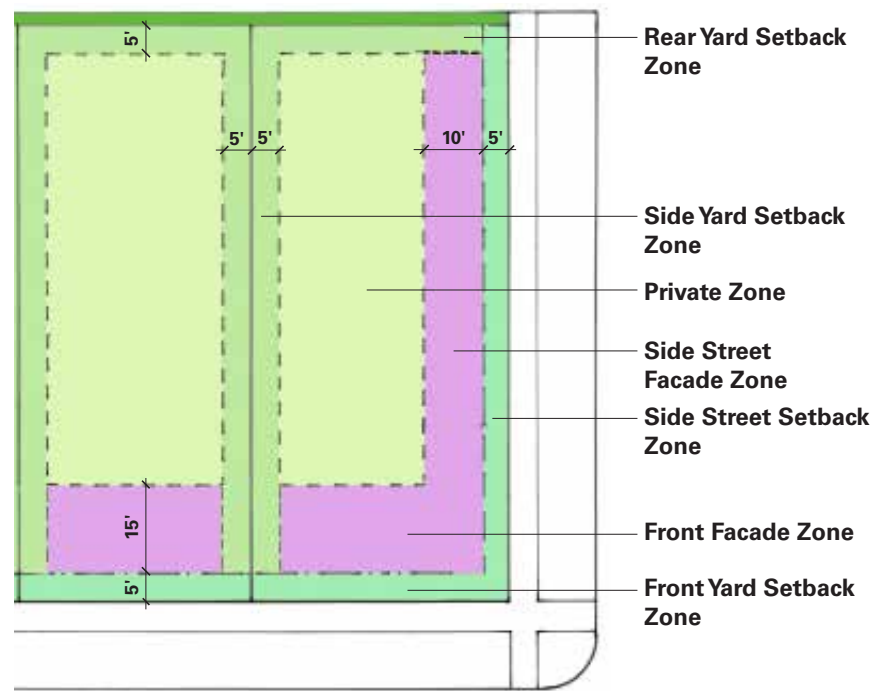

Plan of Bungalow zones and setbacks

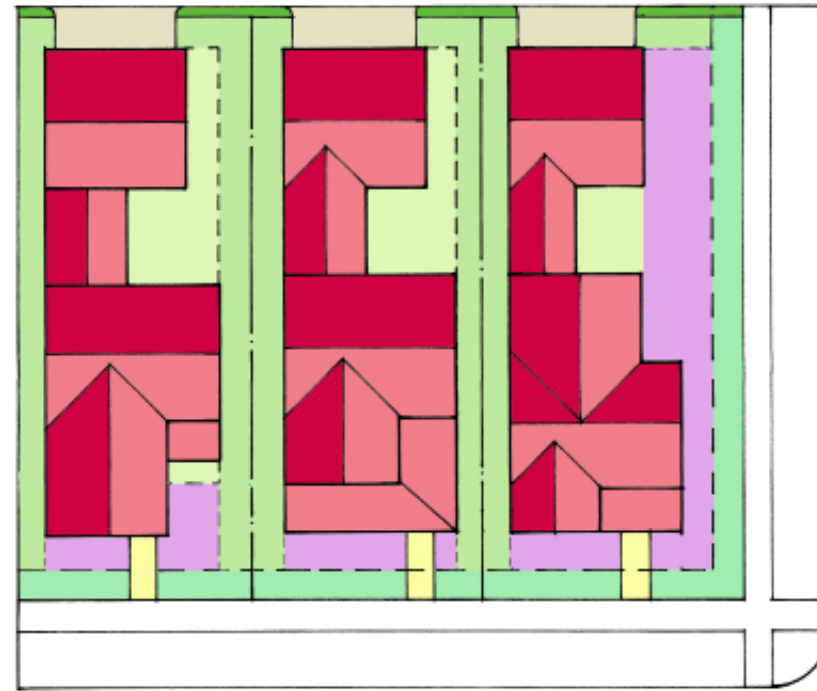

Illustrative plan of Bungalow house placement on lot

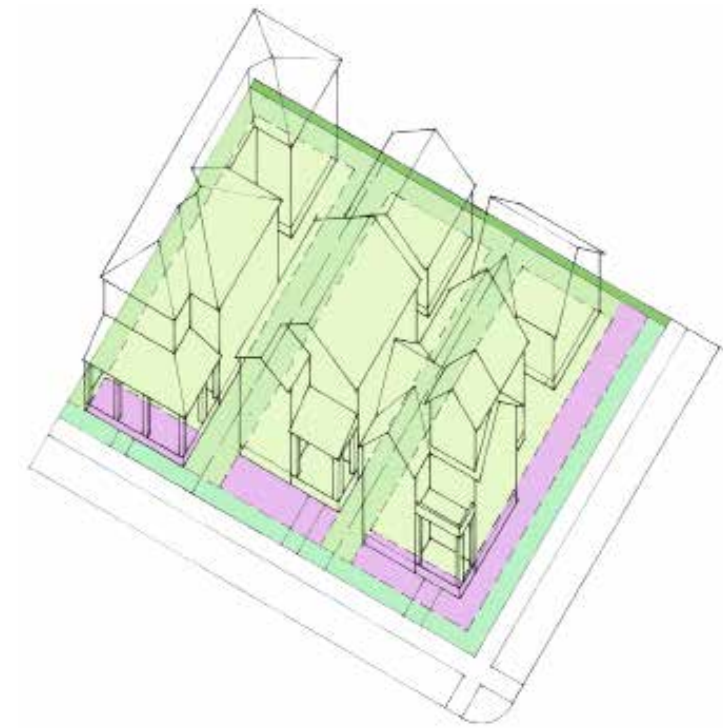

Bungalow Lots – General Conditions

Lot Size

Bungalow lots are approximately 40 feet wide by 100 feet deep. Corner lots are approximately 45 feet wide.

Front Yard Setback/ Front Facade Zone

Minimum five-foot setback from the front property line to the house. The front facade of the house may be located anywhere within the adjacent 15-foot-deep Front Facade Zone. A minimum of 65% of the front facade shall be within the Front Facade Zone.

Side Yard Setback

Minimum five-foot setback from the side property line.

Side Street Setback/ Side Street Facade Zone

Minimum five-foot setback from the side street property line to the house. The side street facade may be located anywhere within the adjacent ten-foot-deep Side Street Facade Zone. Garage doors must face the rear lane right-of-way and are not permitted within the Side Street Facade Zone. A minimum of 30% of the side street facade shall be within the Side Street Facade Zone.

Rear Yard Setback

All structures shall be set back a minimum of five feet from the rear property line.

Encroachments

Porches and bay windows, if included, must be located within the Front Facade and/or Side Street Facade Zones.

Garage Requirements

Garages shall be set back a minimum of five feet as required under Rear Yard Setbacks. If the design includes a parking pad, garages shall be set back a minimum of 18 feet from the rear lane right-of-way. A minimum of two parking spaces per unit is required.

Fencing Recommendations

Front yard fences are a permitted upgrade. Rear and side yard fences are required for privacy. For additional fencing guidelines, see the Landscape Patterns section of this Pattern Book (page D 11).

Open Space Requirement

Fifteen percent of the buildable lot area (Private, Front Facade, and Side Street Facade Zones) shall be maintained as open space.

Accessory Unit (Carriage House)

An accessory unit is permitted over the garage (see Carriage House guidelines, page B 12). A minimum of one additional off-street parking space is to be provided for the accessory unit.

Living Area Limit

The maximum living area limit for Bungalow Lots is 3150 square feet.

Bungalow Lots



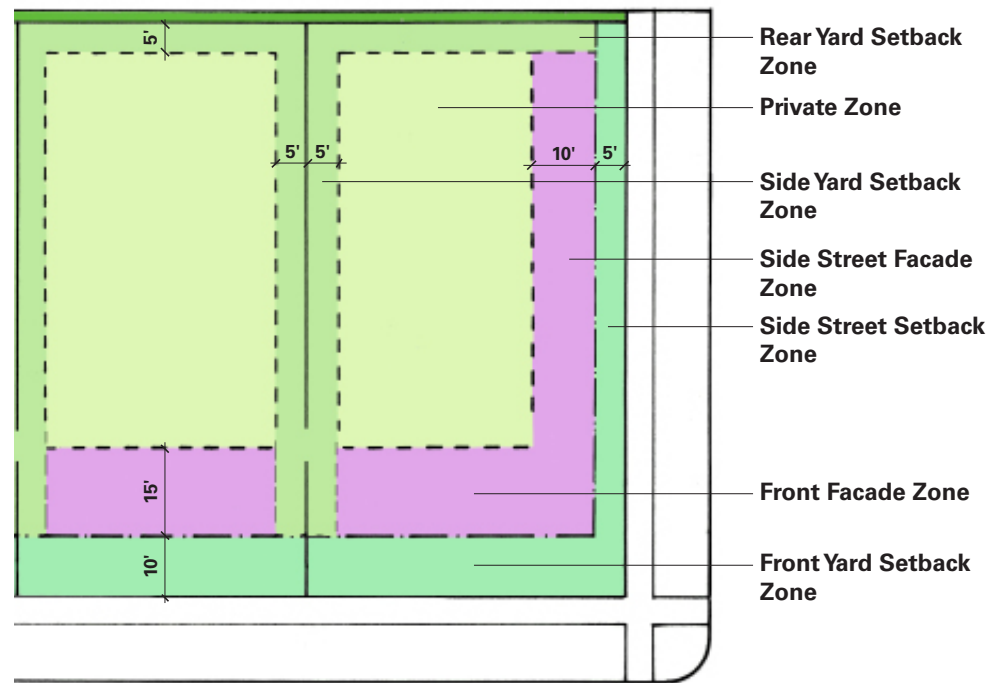

Plan of Village zones and setbacks

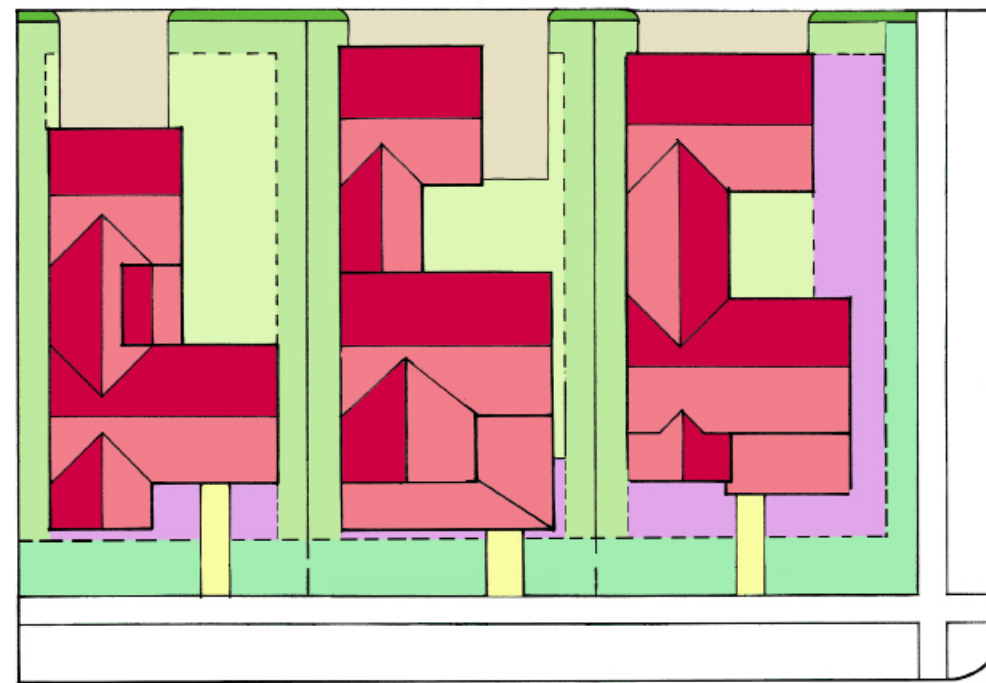

Illustrative plan of Village house placement on lot

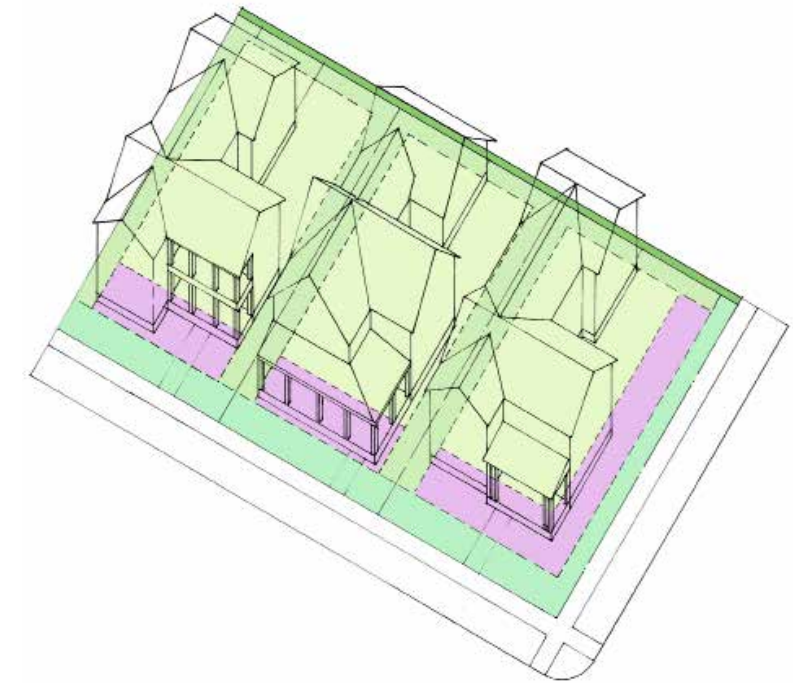

Village Lots – General Conditions

Lot Size

Village lots are approximately 50 feet wide by 100 feet deep. Corner lots are approximately 55 feet wide.

Front Yard Setback/ Front Facade Zone

Minimum ten-foot setback from the front property line to the house. The front facade of the house may be located anywhere within the adjacent 15-foot-deep Front Facade Zone.

Side Yard Setback

Minimum five-foot setback from the side property line.

Side Street Setback/ Side Street Facade Zone

Minimum five-foot setback from the side street property line to the house. The side street facade may be located anywhere within the adjacent ten-foot-deep Side Street Facade Zone.

Rear Yard Setback

All structures shall be set back a minimum of five feet from the rear property line.

Encroachments

Porches and bay windows, if included, must be located within the Front Facade Zone and/or Side Street Facade Zones.

Garage Requirements

Garages shall be set back a minimum of five feet as required under Rear Yard Setbacks. If the design includes a parking pad, garages shall be set back a minimum of 18 feet from the rear lane right-of-way. Pad parking is permitted adjacent to garages. A minimum of two parking spaces per unit is required. A minimum of two spaces shall be covered.

Fencing Recommendations

Front yard fences are a permitted upgrade. Rear and side yard fences are required for privacy. For additional fencing guidelines, see the Landscape Patterns section of this Pattern Book (page D 11).

Open Space Requirement

Fifteen percent of the buildable lot area (Private, Front Facade, and Side Street Facade Zones) shall be maintained as open space.

Accessory Unit (Carriage House)

An accessory unit is permitted over the garage (see Carriage House guidelines, page B 12). A minimum of one additional off-street parking space is to be provided for the accessory unit.

Living Area Limit

The maximum living area limit for Village Lots is 2660 square feet.



Village Lots

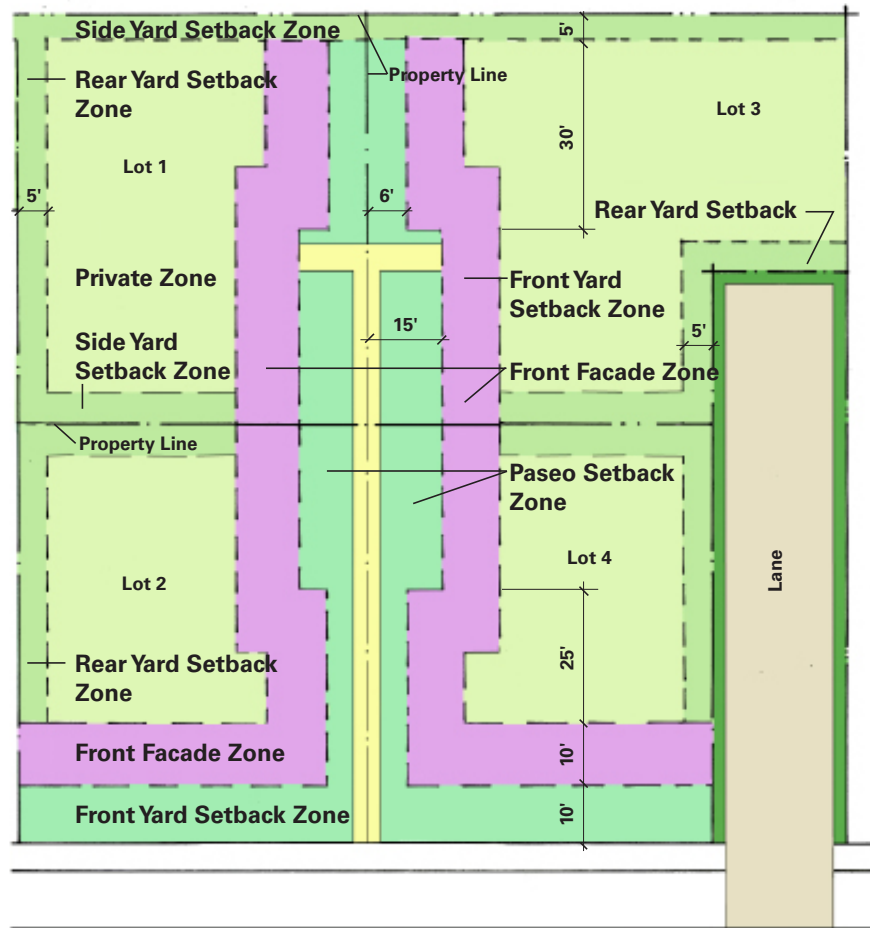

Plan of Courtyard zones and setbacks

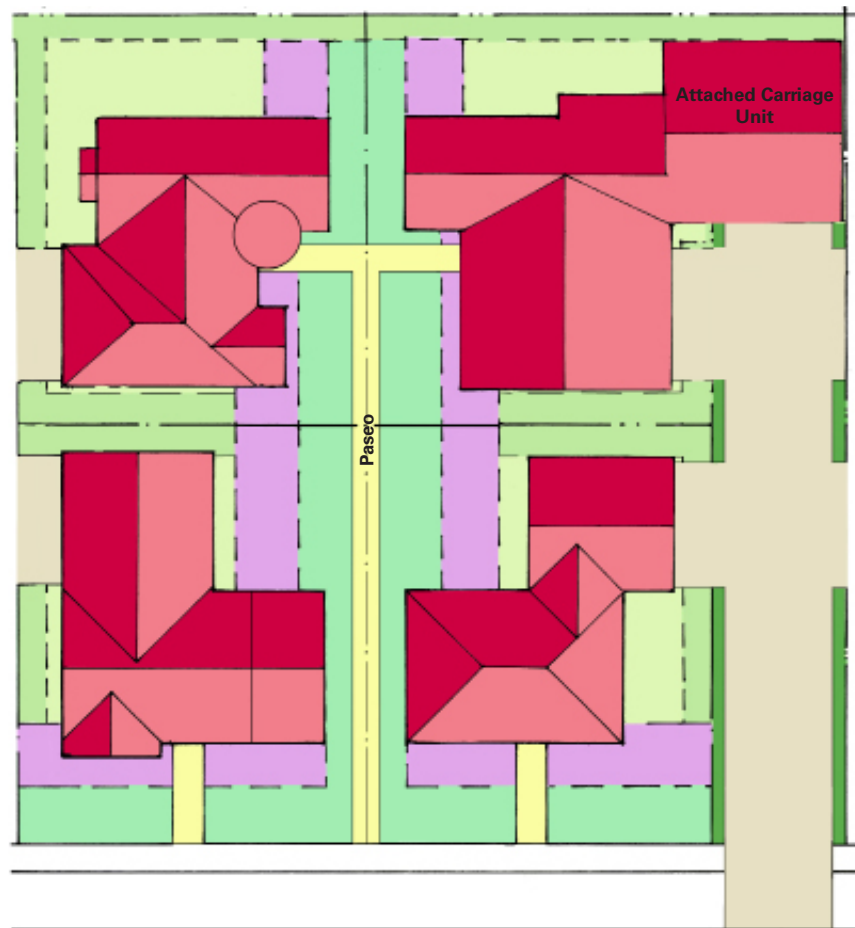

Illustrative plan of Courtyard house placement on lot



Courtyard Lots – General Conditions

Lot Size

Courtyard lots are approximately 65 feet wide by 70 feet deep.

Front Yard Setback/ Front Facade Zone

Minimum ten-foot setback from the front property line to the house. The front facade of the house may be located anywhere within the adjacent ten-foot-deep Front Facade Zone. A minimum of

50% of the front facade shall be within the Front Facade Zone.

Side Yard Setback

Minimum five-foot setback from the side property line. All setbacks not designated Front or Rear are Side Yards.

Rear Yard Setback

All structures shall be set back a minimum of five feet from the lane right-of-way or the rear property line.

Garage Requirements

Garages shall be located a minimum of five feet from the rear lane right-of-way. A minimum of two parking spaces per unit is required.

Fencing Recommendations

Front yard fences are a permitted upgrade. Rear and side yard fences are required for privacy. For permitted fence location and additional fencing guidelines, see the Landscape Patterns section of this Pattern Book (D 11).

Open Space Requirement

Fifteen percent of the buildable lot area (Private and Front Facade Zones) shall be maintained as open space.

Accessory Unit (Carriage House)

An accessory unit is permitted at the head of the lane over the garage. A minimum of one additional off-street parking space is to be provided for the accessory unit.

Living Area Limit

The maximum living area limit for Courtyard Lots is 3510 square feet.

Courtyard Lots



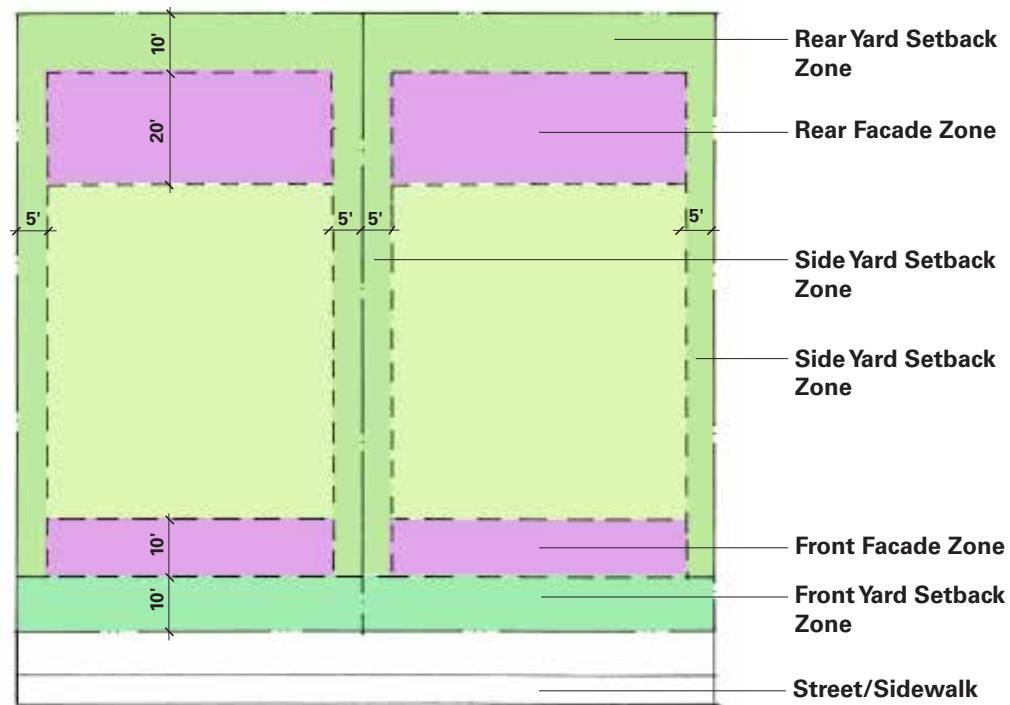

Plan of Bluff zones and setbacks

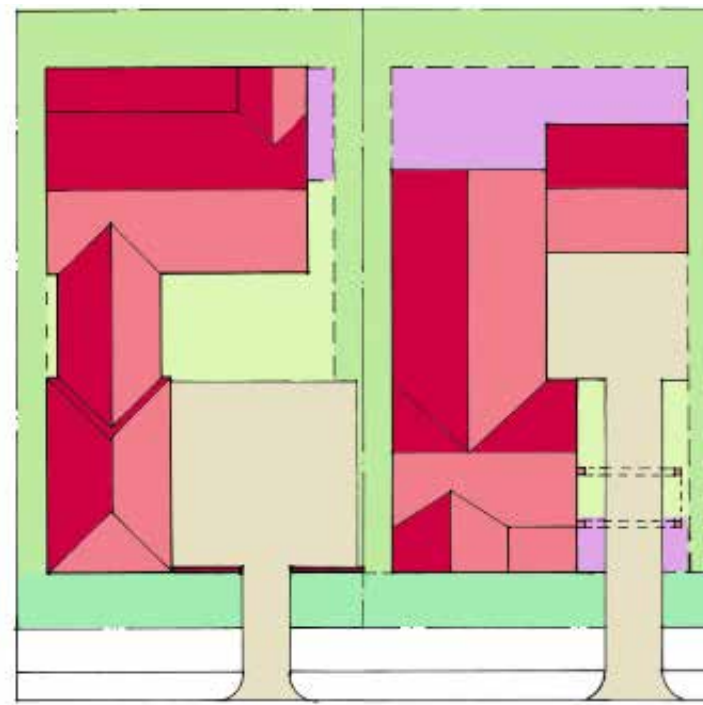

Illustrative plan of Bluff house placement on lot

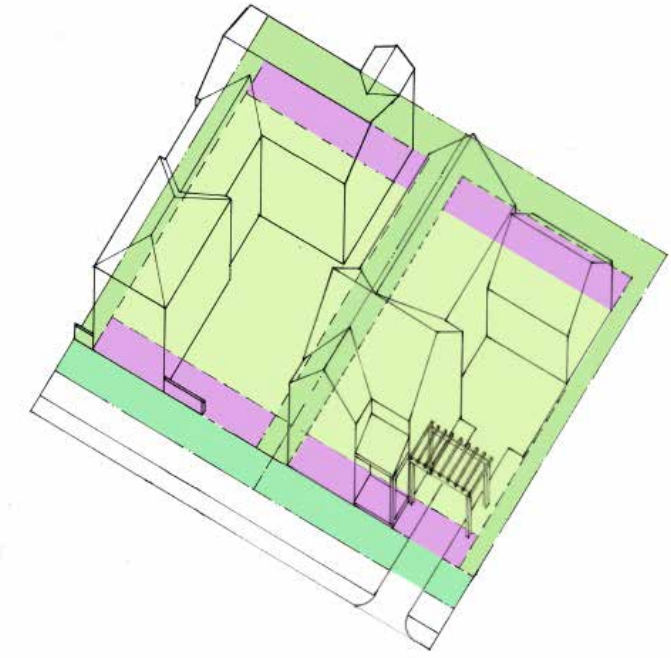

Bluff Lots – General Conditions

Lot Size

Bluff lots are approximately 50 feet wide by 100 feet deep.

Front Yard Setback/ Front Facade Zone

Minimum ten-foot setback from the front property line to the house, garage, or carriage house. The street-facing facade of the house, garage, or carriage house may be located anywhere within the adjacent ten-foot-deep Front Facade Zone.

Side Yard Setback

Minimum five-foot setback from the side property line.

Rear Yard Setback/Rear Facade Zone

All structures shall be set back a minimum of ten feet from the rear property line. The rear-facing facade of the house may be located anywhere within the adjacent 20-foot-deep Rear Facade Zone.

Encroachments

No encroachments are permitted in required setbacks, including ancillary structures such as sheds, pools, hot tubs, and mechanical equipment.

Garage Requirements

Parking courtyards are required. Garage doors shall face parking courtyards. Driveways shall be a maximum of 11 feet wide within the Front Yard Setback and Front Facade Zones.

Fencing Recommendations

Although not required, front yard fences or walls are encouraged as a permitted upgrade for all Bluff lots. These shall be placed two feet from the front property line. For additional fencing requirements, see the Landscape Patterns section of this Pattern Book.

Open Space Requirement

Twenty percent of the buildable lot area (Private, Front Facade, and Rear Facade Zones) shall be maintained as open space.

Accessory Unit (Carriage House)

An accessory unit is permitted over the garage. A minimum of one additional off-street parking space is to be provided for the accessory unit.

Living Area Limit

The maximum living area limit for Bluff Lots is 3750 square feet.

Bluff Lots



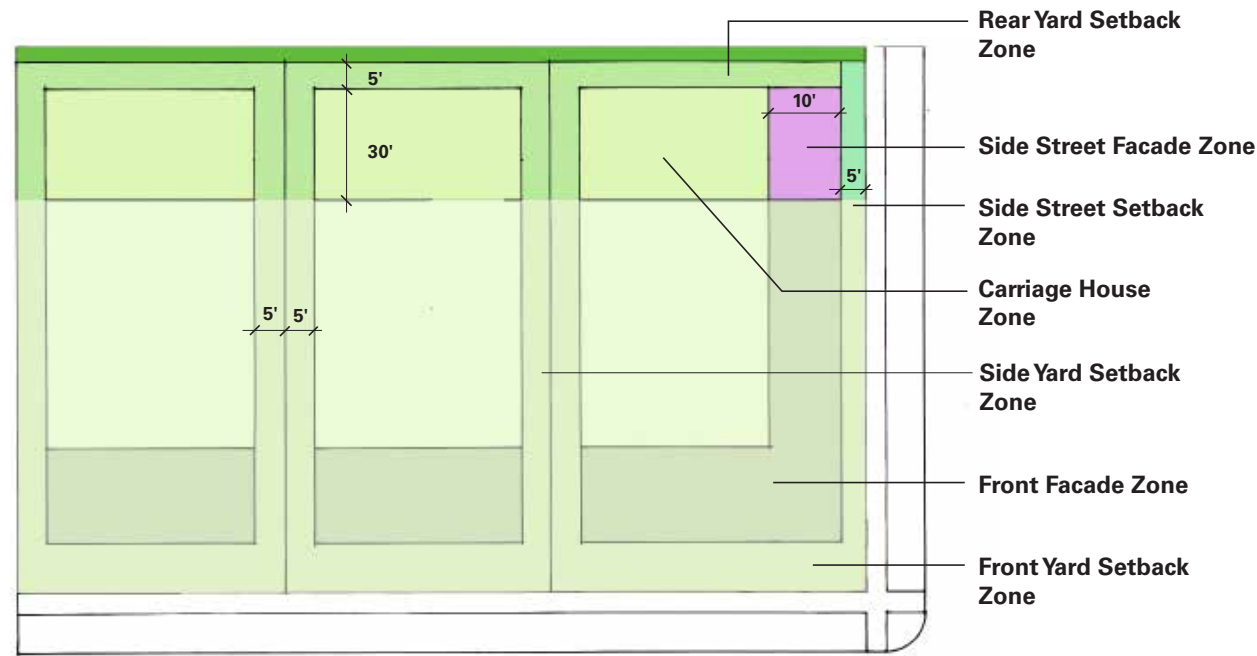

Plan of zones and setbacks



Illustrative plan of Carriage House placement on a lot

Carriage Houses – General Conditions

Lot Size

Carriage houses are permitted on Bungalow, Village, Bluff, and also on Courtyard lots (where feasible). The conditions illustrated above apply only to carriage houses on Bungalow and Village lots. Individual lot conditions will dictate placement of carriage houses on Bluff and Courtyard lots. Seventy carriage house lots will be designated, divided equally into each phase (23 in the first phase and 24 in the second), and concurrent with filing the Final Map for each phase. The carriage house rights may be relocated to another lot within the same phase.

Main Body

Carriage houses range from approximately 22 to 36 feet in width by approximately 22 to 27 feet deep; these units are placed above two- or three-car garages. The maximum floor area for a carriage house is 700 square feet.

Side Yard Setback

The minimum setback from the side property line shall be in congruence with the side yard setback requirement for the corresponding lot type.

Side Street Setback / Side Street Facade Zone

Minimum five-foot setback from the side street property line to the carriage house. The side street facade may be located anywhere within the adjacent ten-foot-deep Side Street Facade Zone.

Carriage House Requirements

Carriage houses shall be set back a minimum of five feet from the rear property line. One additional off-street parking space is required to accommodate the parking for the carriage house. It may be a parking pad, carport, or garage space.

Carriage Houses



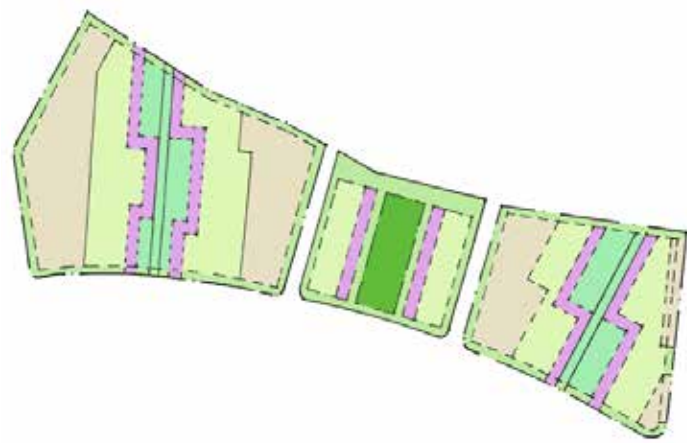

Illustrative diagram of zones and setbacks on Site A



Illustrative plan showing possible building placement on Site A

- Setback Zone
- Front Facade Zone
- Building Zone
- Apartment Paseo
- Townhouse Paseo
- Parking



Illustrative view of Court Apartments

Court Apartments/Townhomes – General Conditions, Site A

Apartment and townhome sites in East Garrison are included in the neighborhoods adjacent to a variety of other lot types. In the Phase 1 and Phase 2 neighborhoods, there are sites designated for Court Apartments/Townhomes. Buildings will be designed in the Mediterranean Revival style, and arranged on the site to create a series of courtyard and garden spaces as a shared public address. Walkways and passages will link the courts and gardens to surface parking areas. More private common areas are located between the parking areas and the buildings. Apartments over garages are encouraged. See Table 3.9 for permitted building heights.

Front Yard Setback/ Front Facade Zone

Minimum five-foot setback from the front property line to the unit. The front facade of the unit may be located anywhere within the adjacent fifteen-foot-deep Front Facade Zone.

Side Yard Setback

Since the units are multi-family, there is no required side yard setback. See side street setback requirements for regulations concerning corner units.

Side Street Setback/ Side Street Facade Zone

A minimum five-foot setback from the side street property line to the unit. The side street facade may be located anywhere within the adjacent fifteen-foot-deep Side Street Facade Zone.

Rear Yard Setback

All structures shall be set back a minimum of five feet from the rear property line. All structures shall also be set back a minimum of 15 feet from the centerline of driving lanes.

Minimum Building Spacing

Buildings must be a minimum of ten feet apart.

Encroachments

Porches, bay windows, if included, may encroach up to two feet into both the Front Yard and Side Street Setback Zones.

Parking Requirements

See Section 3.5.4 Parking Requirements in the EGSP.

Fencing Requirements

Front yard fences are a permitted upgrade. Rear and side yard fences are permitted for privacy. Privacy fencing is also required around recycling and trash

areas. Screening from ground-level view shall be placed on all sides and shall be of the same finishing material used on the principal building.

Open Space Requirements

In addition to required perimeter setbacks, parking areas, and driving lanes, Court Apartment/Townhomes parcels have a 15% open space requirement. A minimum of one tot lot is required.

Plan Review

In addition to approval by the Design Review Committee, the Salinas Rural Fire District must approve fire access in the final site plan.

Refuse Storage

Refuse containers will be integrated into off-street parking areas behind buildings. They must be of sufficient size to meet required trash and recycling needs. Recycling and trash containers shall have separate access.

Court Apartments/Townhomes – Site A





Illustrative diagram of zones and setbacks on Site B



Illustrative plan showing possible building placement on Site B

- Setback Zone
- Front Facade Zone
- Building Zone
- Townhouse Paseo
- Parking

Court Apartments/Townhomes – General Conditions, Site B

Apartment and townhome sites in East Garrison are included in the neighborhoods adjacent to a variety of other lot types. In the Phase 1 and Phase 2 neighborhoods, there are sites designated for Court Apartments/Townhomes. Buildings will be designed in the Mediterranean Revival style, and arranged on the site to create a series of courtyard and garden spaces as a shared public address. Walkways and passages will link the courts and gardens to surface parking areas. More private common areas are located between the parking areas and the buildings. Apartments over garages are encouraged. See Table 3.9 for permitted building heights.

Front Yard Setback/ Front Facade Zone

Minimum five-foot setback from the front property line to the unit. The front facade of the unit may be located anywhere within the adjacent fifteen-foot-deep Front Facade Zone.

Side Yard Setback

Since the units are multi-family, there is no required side yard setback. See side street setback requirements for regulations concerning corner units.

Side Street Setback/ Side Street Facade Zone

A minimum five-foot setback from the side street property line to the unit. The side street facade may be located anywhere within the adjacent fifteen-foot-deep Side Street Facade Zone.

Rear Yard Setback

All structures shall be set back a minimum of five feet from the rear property line. All structures shall also be set back a minimum of 15 feet from the centerline of driving lanes.

Minimum Building Spacing

Buildings must be a minimum of ten feet apart.

Encroachments

Porches, bay windows, if included, may encroach up to two feet into both the Front Yard Setback, Side Street Setback, and Townhouse Paseo Zones.

Parking Requirements

See Section 3.5.4 Parking Requirements in the EGSP.

Fencing Requirements

Front yard fences are a permitted upgrade. Rear and side yard fences are permitted for privacy. Privacy fencing is also required around recycling and trash areas. Screening from ground-level view



Illustrative view of Court Apartments

shall be placed on all sides and shall be of the same finishing material used on the principal building.

Open Space Requirements

In addition to required perimeter setbacks, parking areas, and driving lanes, Court Apartment/Townhomes parcels have a 15% open space requirement. A minimum of one tot lot is required.

Plan Review

In addition to approval by the Design Review Committee, the Salinas Rural Fire District must approve fire access in the final site plan.

Refuse Storage

Refuse containers will be integrated into off-street parking areas behind buildings. They must be of sufficient size to meet required trash and recycling needs. Recycling and trash containers shall have separate access.

Court Apartments/Townhomes – Site B





Illustrative diagram of zones and setbacks



Illustrative plan showing possible building placement

- Setback Zone
- Front Facade Zone
- Building Zone
- Parking



Illustrative view of the Town Center

Garrison Town Center – General Conditions

Front Yard Setback/ Front Facade Zone

Minimum five-foot setback from the face of the property line. The front facade of the buildings may be located anywhere within the adjacent fifteen-foot-deep Front Facade Zone.

Side Yard Setback

Minimum five-foot setback from the side property line.

Side Street Setback/Side Street Facade Zone

Minimum five-foot setback from the side street property line to the building. The side street facade may be located anywhere within the adjacent fifteen-foot-deep Side Street Facade Zone

Rear Yard Setback/Rear Facade Zone

All structures shall be set back a minimum of seven feet from the edge of parking and/or rear property line. Minimum setback to parking is five feet from all property lines.

Encroachments

Porches, bay windows, balconies, and awnings, if included, may encroach up to five feet into the Setback Zones, but not over the property line.

Parking Requirements

See Section 3.5.4 Parking Requirements in the EGSP.

Fencing Recommendations

Fencing in the Setback Zones is prohibited. Rear Yard fencing, 36" high, is permitted. Screening from ground level view shall be placed on all sides and shall be of the same finishing material used on the principal building.

Refuse Storage

Commercial units shall maintain separate refuse and recycling storage containers from those used by residents. These containers must be integrated into the building envelope.

Garrison Town Center

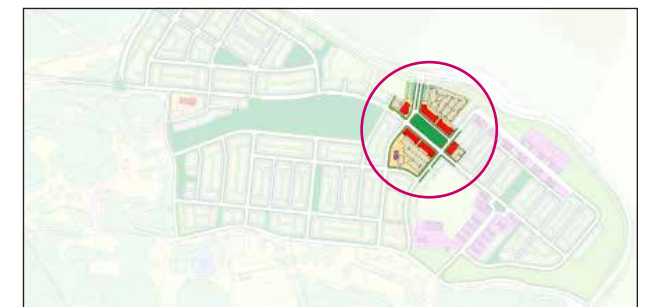

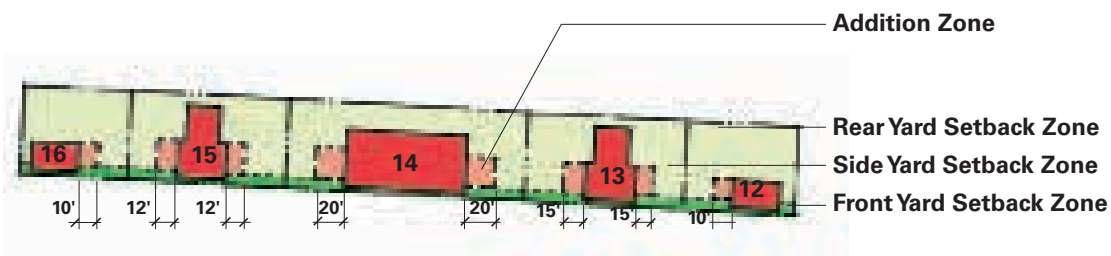

Plan of administrative buildings zones and setbacks



Plan of warehouse buildings zones and setbacks

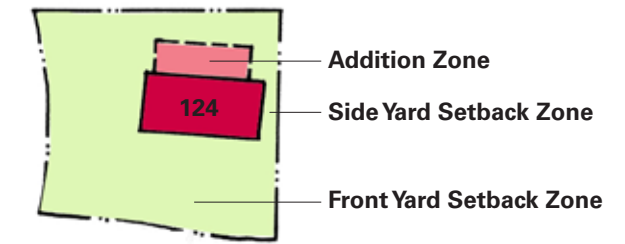

Plan of Gun Club building zones and setbacks

Additions to Contributing Historic Structures – General Conditions

Lot Size

There is no minimum lot size.

Front Yard Setback/Front Facade Zone

Minimum eight-foot setback from building facades that face existing and proposed streets (porches to be excluded from measurements).

Side Yard Setback

Minimum five-foot setback from the side property line to the addition. Setbacks may be greater than five-feet as indicated in the regulating drawing above.

Side Street Setback/

Side Street Facade Zone

Minimum five-foot setback from the side street property line to the addition. Setbacks may be greater than five-feet as indicated in the regulating drawing above.

Rear Yard Setback/

Rear Yard Facade Zone

All structures shall be set back a minimum of five-feet from the rear property line.

Encroachments

Encroachments into Setback Zones are not permitted.

Protected Buildings

Additions to the Chapel are not permitted.

Fencing Regulations

In general, fences are not permitted on the sites of existing contributing historic buildings. The only exception is fencing around recycling and trash enclosures. Privacy fencing is required around recycling and trash areas.

Screening from ground level view shall be placed on all sides and shall be of the same finishing material used on the principal building.

Open Space Requirement

30% of the lot area shall be maintained as open space.

Parking Requirements

See Section 3.5.4 Parking Requirements in the EGSP

Building Heights

The height of building additions may not exceed the height of the existing contributing historic building. See also Section 3.5.3 Height Limits in the EGSP.

Contributing Historic Buildings

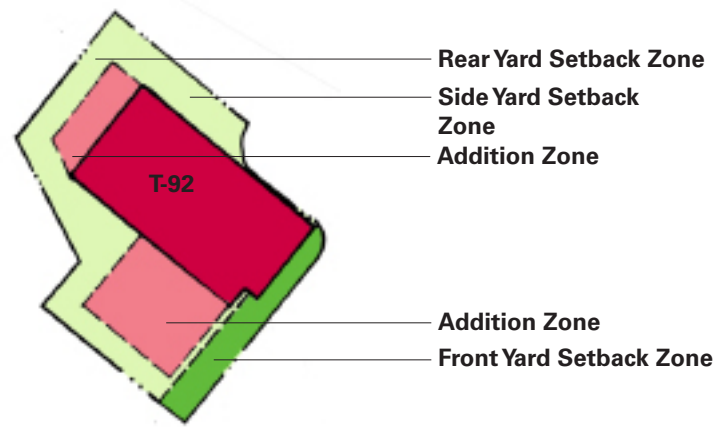

Plan of Theater zones and setbacks

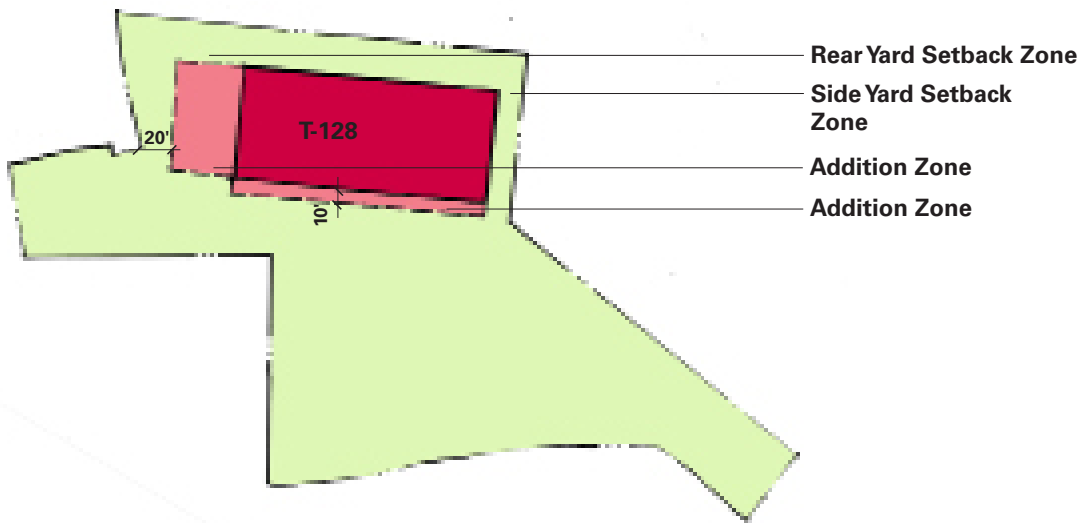

Plan of Battle Simulation zones and setbacks

Additions to Wood Buildings – General Conditions

Lot Size

There is no minimum lot size.

Front Yard Setback/ Front Facade Zone

Minimum eight-foot setback from building facades that face existing and proposed streets (porches to be excluded from measurements). If a building is demolished and a new building built, the new building is subject to these same setback requirements (the existing building footprint plus permitted additions).

Side Yard Setback

Minimum twenty-foot setback from the side property line to the addition. Setbacks may be greater than twenty-feet as indicated in the regulating drawing above.

Side Street Setback/ Side Street Facade Zone

Minimum twenty-foot setback from the side street property line to the addition. Setbacks may be greater than twenty-feet as indicated in the regulating drawing above.

Rear Yard Setback/ Rear Yard Facade Zone

All structures shall be set back a minimum of five-feet from the rear property line.

Encroachments

Encroachments into Setback Zones are not permitted.

Protected Buildings

Additions to the Chapel are not permitted.

Fencing Regulations

In general, fences are not permitted on the sites of existing wood buildings. The only exception is fencing around recycling and trash enclosures. Privacy fencing is required around recycling and trash areas. Screening from ground level view shall be placed on all sides and shall be of the same finishing material used on the principal building.

Open Space Requirement

30% of the lot area shall be maintained as open space.

Parking Requirements

See Section 3.5.4 Parking Requirements in the EGSP

Building Heights

The height of building additions may not exceed the height of the existing wood building. See also Section 3.5.3 Height Limits in the EGSP.

Wood Buildings

Lot Type	Uses	Lot Size		Facade Zones		Setbacks		Off-Street Parking	Encroachments
		Width	Depth	Front	Side St.	Side Yd.	Rear		
Townhouse Lots	Attached Single-Family Residential	18' to 30'	70'	5' to 15'	5' to 10'	n/a	5'	2 Spaces	Porches and/or Bay Windows: 2' into the Front Yard and Side Street Setback Zones
Live/Work Townhouse Rowhouse Lots	Attached Single-Family Residential w/Ground-Floor, Non-Residential or Residential Uses.	18' 16' to 30'	70' 55'	0' to 10'	5' to 10'	n/a	5'	2 Spaces	Bay Windows: 2' into the Side Street Setback Zone
Hamlet Lots	Single-Family Residential Detached	30' to 40'	55'	5' to 15'	5' to 15'	4'	5'	2 spaces	Porches and/or Bay Windows: 2' into the Front Yard and Side Street Setback Zones
Grove Lots	Single-Family Residential Detached	30' to 35'	70'	5' to 15'	5' to 15'	4'	5'	2 Spaces	Porches and/or Bay Windows: 2' into the Front Yard and Side Street Setback Zones
Garden Lots	Single-Family Residential Detached	35' to 40'	70'	5' to 15'	5' to 15'	4'	5'	2 Spaces	Porches and/or Bay Windows: 2' into the Front Yard and Side Street Setback Zones
Bungalow Lots	Single-Family Residential Detached	40' to 45'	100'	5' to 20'	5' to 15'	5'	5'	2 Spaces	None permitted
Village Lots	Single-Family Residential Detached	50' to 55'	100'	10' to 25'	5' to 15'	5'	5'	2 Spaces	None permitted
Courtyard Lots	Single-Family Residential Detached	65'	70'	10' to 20'	n/a	5'	5'	2 Spaces	None permitted
Bluff Lots	Single-Family Residential Detached	50'	100'	10' to 20'	n/a	5'	10'	2 Spaces	None permitted
Carriage Houses	Accessory Units	varies		n/a	5' to 15'	5'	5'	1 Space	None permitted

Note: Eaves are permitted to encroach into setbacks and required open space.

Summary of Lot Specifications

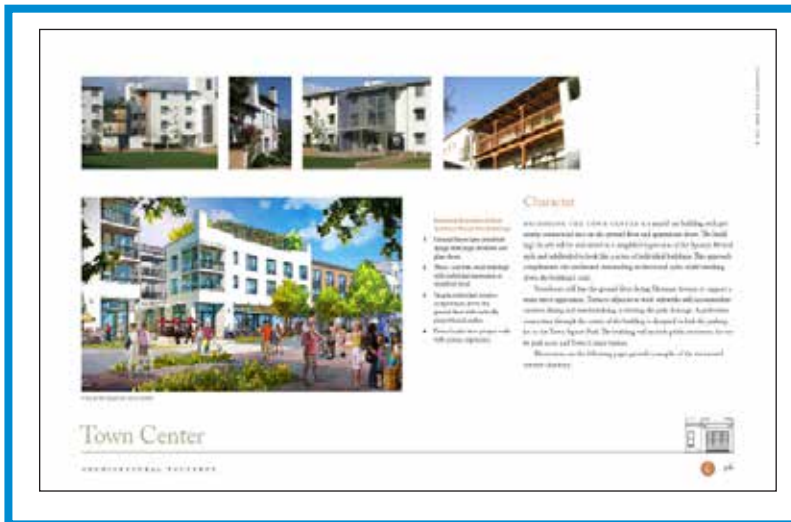
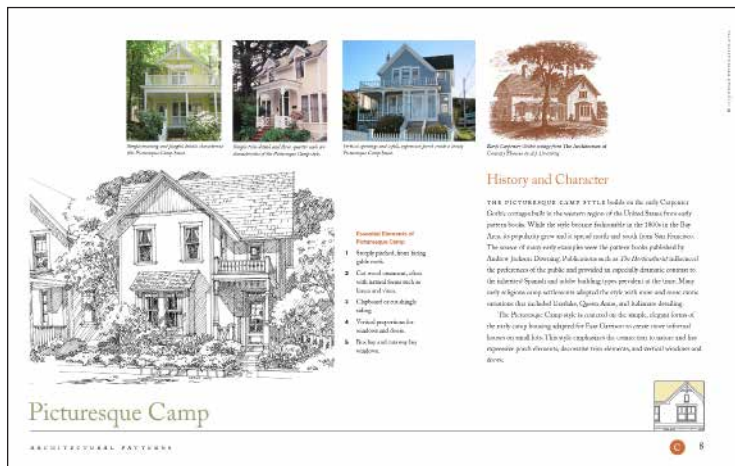

Overview

THE ARCHITECTURAL PATTERNS SECTION illustrates key elements and design strategies for the four permitted traditional architectural styles and two specific places—the Town Center and the Artist Lofts [Live/Work Rowhouses](#)—each of which has special architectural characteristics. This section provides detailed guidelines for designing within the prescribed styles while creating well-defined variations among houses and buildings. The approach used is not intended to be a comprehensive catalog of all possibilities, but rather to serve as a guide to the key components within a particular style or, in the case of the Town Center and the Artist Lofts [Live/Work Rowhouses](#), to a particular place.

Each style section begins with an overview and general description of the style followed by several pages that document key massing types and eave types, standard door and window compositions, window and door proportions and characteristics, typical porch types and details, and, finally, materials and possibilities based on East Garrison Pattern Book components. Variations or other alternative combinations of components are permitted so long as they generally conform to the particular style. The goal is to design within specific families of styles that are appropriate to the East Garrison context, not to design historic reproductions. The style pages and the illustrated details are meant to be a menu of options for designing houses in response to market demands and cost constraints while providing, at a minimum, a consistent quality of character and detail.

In order to ensure a variety of house designs and styles along all streets, a maximum of three houses of the same style may be located next to each other. In addition, identical houses (defined as having the same front facade) may not be located on adjacent lots.

Architectural Patterns

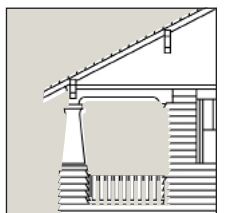



Asymmetrical window and door composition and a mix of siding materials are characteristic of the Garrison Craftsman style.



Simple forms with exposed structural members and deep overhangs are typical.



Towers will be a distinctive element of some Garrison Craftsman houses.



Illustration of Craftsman house from 500 Small Houses of the Twenties

History and Character

GARRISON CRAFTSMAN HOUSES are derived from the unique qualities of the Craftsman tradition found throughout northern California and Monterey County. Many regional builders constructed houses influenced by the Arts & Crafts movement. California versions are characterized by exposed or expressive structural elements such as rafters, columns, beams, lintels, and porch elements. The floor plans were generally open with built-in cabinet work. House exteriors were clapboard or shingle siding mixed with stone and brick or stucco accents and were painted in robust color palettes. The California Craftsman house, which emerged in the beginning of the 20th century, was influenced by both the Arts & Crafts movement and Japanese architecture.

For houses in East Garrison, the emphasis in this style is on simple, structural expression of porch and eave elements using a vocabulary of architectural elements including the Prairie, Japanese, and Swiss styles, as well as influences from the Arts & Crafts movement. A coastal character is important to this style and should be reflected in the use of high-contrast color, consistent with the East Garrison Color Palette, for body and trim details. Forms are simple and reflect dimensioned lumber elements. Windows in this style tend to be vertical in proportion and are typically ganged or paired. Exposed eave brackets on roofs and porches contribute to this image and detail.

Horizontal siding, square and shaped shingle siding patterns, and a mix of stucco and siding materials are key cladding elements. This style also may include unpainted metal roofing and shingled roofs.

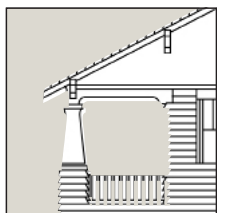

Essential Elements of the Garrison Craftsman

- 1 Pitched roofs with deep overhangs.
- 2 Deep, broad porch elements with expressive structural components.
- 3 Exposed structural elements in the eaves such as rafters and brackets.
- 4 A mixture of materials such as stucco, shingles, and siding.
- 5 Asymmetrical window and door compositions.

Garrison Craftsman

Illustrative Massing Diagrams



Garrison Craftsman

Illustrative Massing Combinations

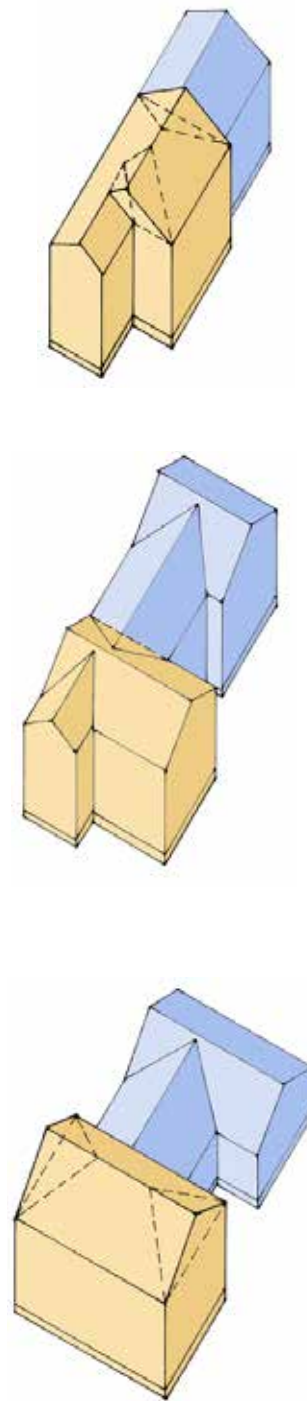

Massing and Composition

Massing

A Two- to Three-Story Front Gable
Hipped or front-gabled rectangular volume. Hip roof pitch is typically 5 to 7 in 12 and gable roof pitch is 6 to 8 in 12. Gabled or hipped front porches are common and have a shallower roof pitch. Porches may be either additive or a single integral bay.

B Two- to Three-Story Narrow Gable-L

Front-facing gable volume with a 5 to 7 in 12 projecting gabled wing. The width of the gable facing the street is typically one-half to two-thirds the width of the main body. Porches are often one bay wide, can be either shed roof or front-facing gable, and typically have a shallower roof pitch.

C Two-Story Basic

Side-gabled rectangular volume with roof pitch of 5 to 7 in 12. One-story, gabled front porches are typically placed to one side. Porches are most often a minimum of two-fifths the length of the main body, and, occasionally, the entire length of the front facade. Porches typically have a shallower roof pitch than the main roof.

D Two-Story Gable-L with Integral Porch

Cross-gabled volume with a 5 to 7 in 12 gable facing the street. Cross gable has a lower slope. The width of the gable facing the street is typically two-thirds that of the main body for houses up to 32 feet

wide and one-half to three-quarters that of the main body for houses 36 feet and over. This massing includes an integral front porch within the gabled projecting wing. Typically, porches have a shallower roof pitch than the main roof.

E Two-Story Wide Gable-L

Cross-gabled volume with a 5 to 7 in 12 gable facing the street. Cross gable can have a lower slope. The width of the gable facing the street is typically half that of the main body for houses up to 32 feet wide and two-fifths that of the main body for houses 36 feet or more. This massing accommodates a variety of porch options, often with a gable emphasizing the entrance.

Facade Composition

Garrison Craftsman facade composition is characterized by an asymmetrical but balanced placement of doors and windows. Standard windows most often occur paired.

Combinations

Complex forms and larger living spaces may be created by combining side and/or rear wings with the main body. Gabled or shed dormers may be added to introduce light into half-story and attic spaces. The architectural character of the attached parts should match that of the main body. Wings must also conform to all setback requirements (see *Community Patterns*).

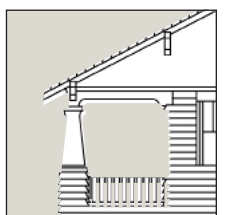

Illustrative Partial Elevation and Section



Eaves

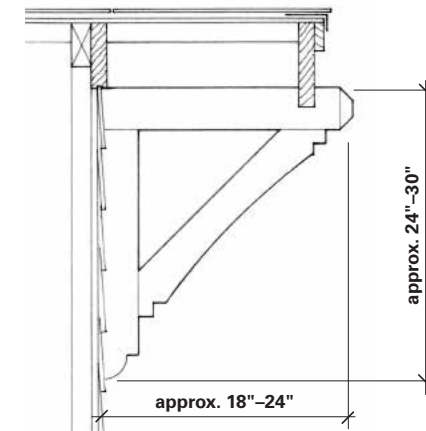

Optional Rake with Bracket

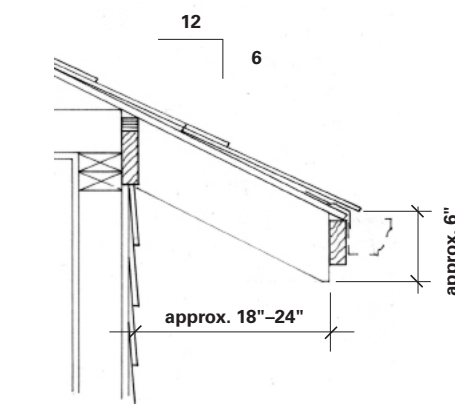

Optional Open Rafter Eave

Massing and Eave Details

Eave Details

Deep eaves with exposed rafters are a dominant characteristic of the Garrison Craftsman style. In some houses, the eave is constructed with brackets at the rake, as illustrated to the left. Where tighter side yard setbacks dictate, a shallower overhang may be necessary.

Two-story main bodies are often characterized by either a change of material, trim application, or change of color between the first and second floor, near the sill line of the second-floor windows, or the head of the first-floor windows.

Towers

A tower can be integrated with the massing to create third-floor living space or an outdoor room with views to the distance.

Finish Floor Elevation

The front door sill should be approximately 18 inches above the adjacent public sidewalk elevation. This may be accomplished by a raised foundation or through lot grading. In either case, front steps are required.



Gable-end eave

Illustrative Tower Configurations

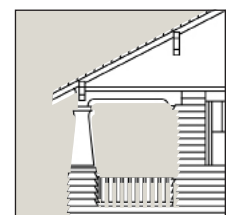
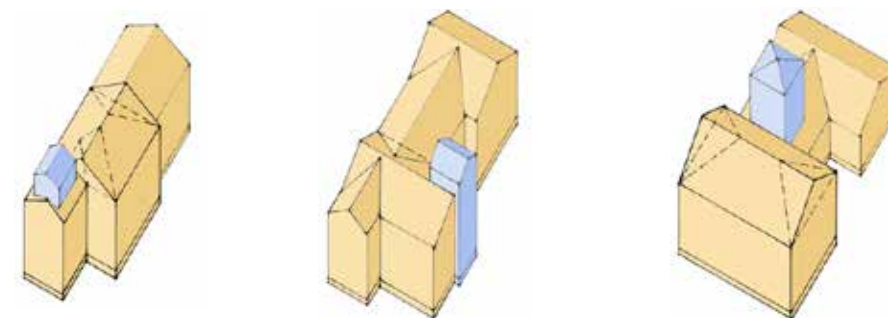

Garrison Craftsman

Standard Windows

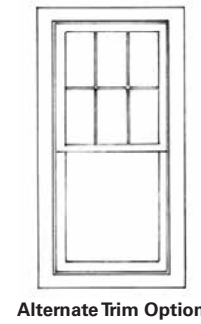
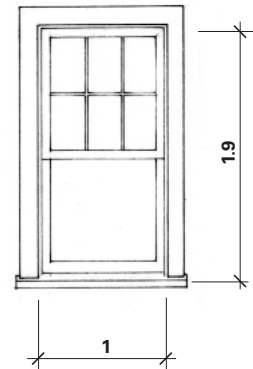
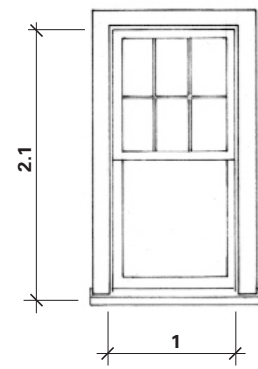

Alternate Trim Option

Second Floor

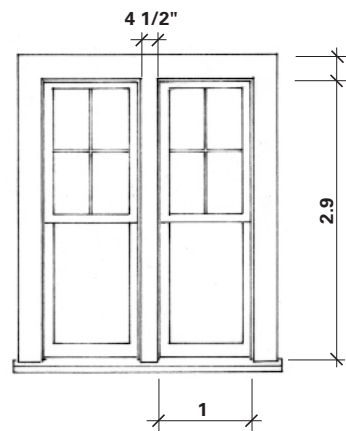
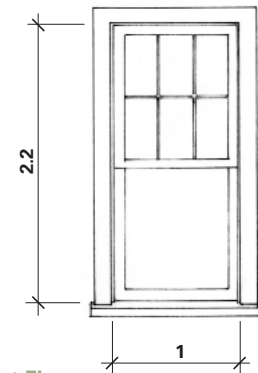

Note: Standard window dimensions represented by approximate proportion of width to height, depending on manufacturer. Trim dimensions represented by actual desired width.

First Floor

Standard Door

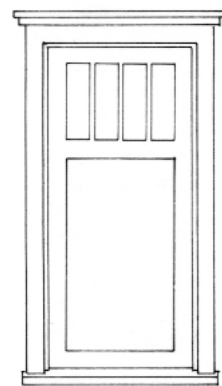

Special Doors-Permitted Upgrade

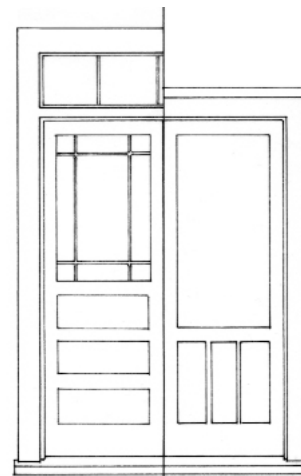
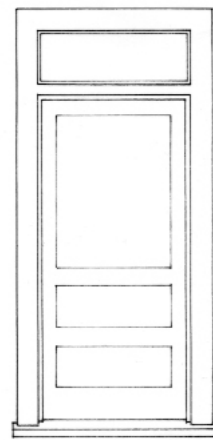

Special Windows-Permitted Upgrade

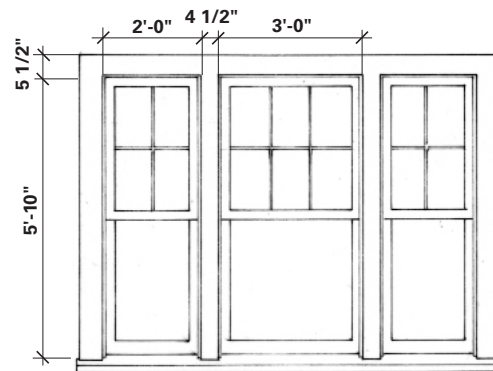
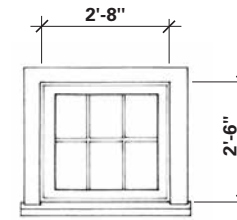
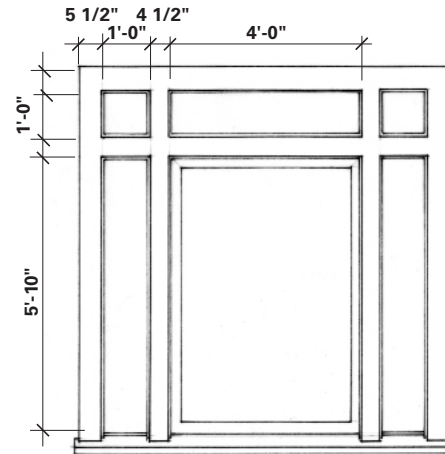

Note: Special window dimensions are approximate. Trim dimensions represented by actual desired width.

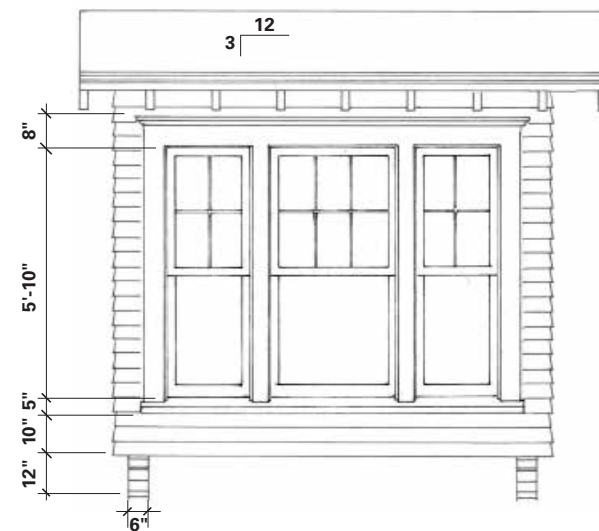

Box Bay Elevation

Windows and Doors

Standard Windows

Windows should be vertical in proportion and may be single, paired, or tripled. Special accent windows are encouraged. Recommended window pane patterns include 6 over 1 and 4 over 1.

Standard Doors

Craftsman doors should be wood with either wood plank design or a panel door with integrated transoms. Fiberglass doors are also permitted. Doors may have decorative, stained glass sidelights and transoms in Arts & Crafts patterns.

Special Windows-Permitted Upgrade

Special windows include picture windows, double-hung windows, and small, square, and rectangular accent windows. Picture windows are typically paired with sidelights and transoms, special pane patterns, or a stained glass upper sash.

Trim

Trim may either be a straight or tapered board, typically 5½ inches wide, with a head that extends beyond the jamb trim.



Characteristically simple trim on a 6 over 1 paired window

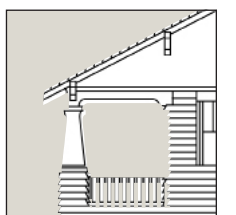

Garrison Craftsman

Porch Placement Diagrams



A Two-Story Front Gable with Side Portico

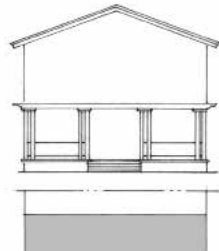

B Two-Story Front Gable with Full Front Porch



C Two-Story Front Gable with Side Entry Portico

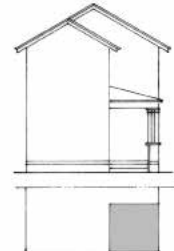

D Two-Story Gable-L with Shed Porch

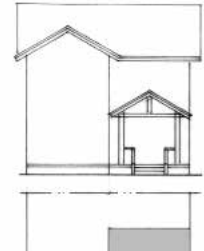

E Two-Story Wide Gable-L with Side Porch

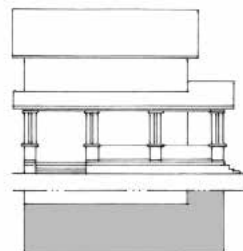

F Two-Story Basic with Wraparound Porch

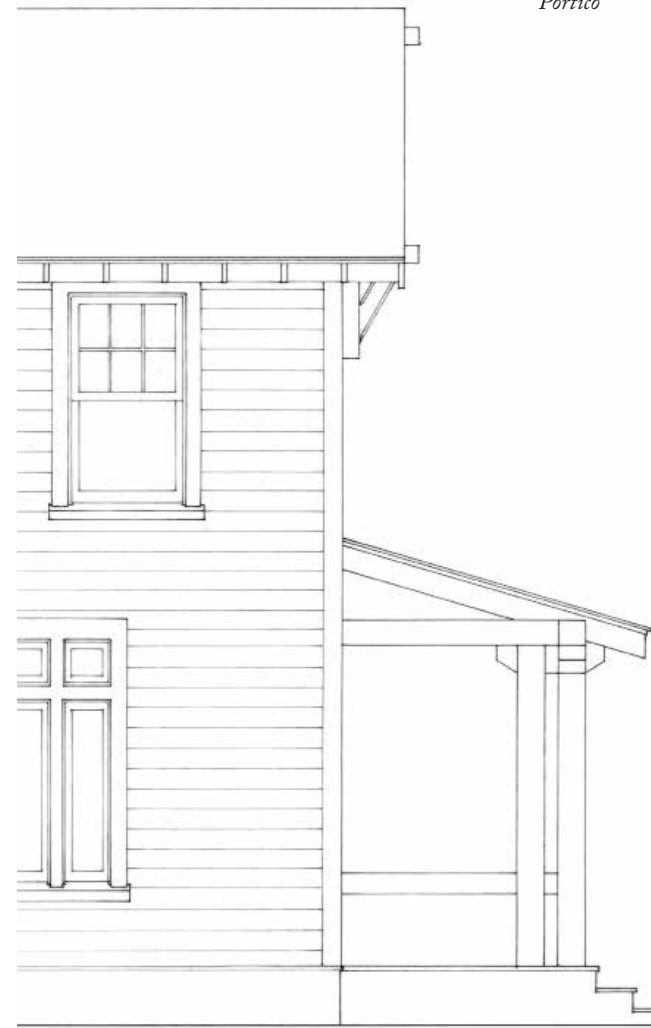

One-story shed porch



One-story gable-end porch

Illustrative Column Types

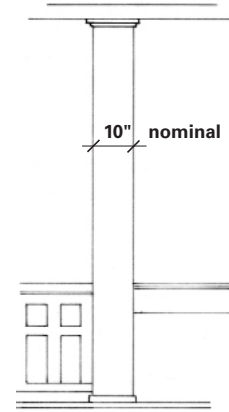

Single Post

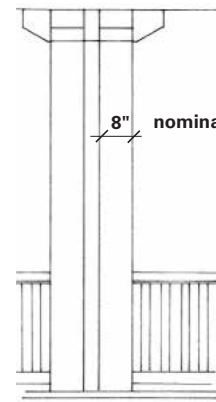

Double Post

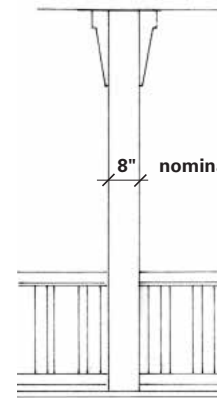

Arts & Crafts

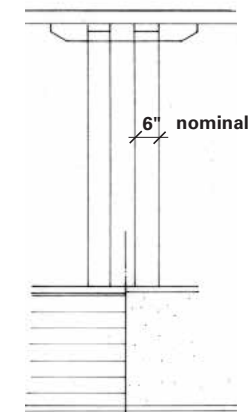

Double Post on Solid Rail

Illustrative Section

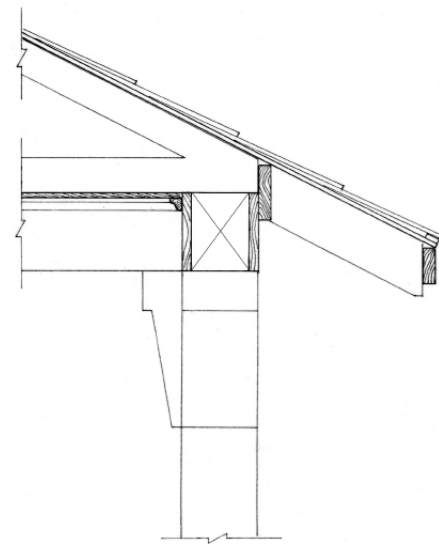

Illustrative Rail Detail

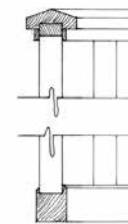

Porches

Porches can be either gable-end porches, shed porches, or combinations of the two forms. Typically the porches have deep eaves often repeating the same rafter treatment as the main roof. Gable-end porches are designed to express the structural elements. Column types include square posts (often in pairs or multiple groupings).



Craftsman porch details are structurally expressive.

Garrison Craftsman

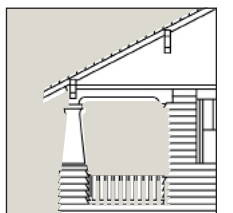

Possibilities



Attached Houses

Materials, Colors, and Possibilities

Materials

Siding: Fiber-cement clapboard and/or stucco. Lace finish not permitted.

Roofing: Composition shingles, flat concrete tile, standing seam, or 5v crimp metal.

Windows: Single- or double-hung, energy-efficient wood, PVC-clad, cellular PVC, aluminum-clad, aluminum, or vinyl with traditional-looking profiles.

Trim: Stucco, wood, composition board, cellular PVC, or polyurethane.

Columns/Brackets: Wood or composite.

Railings: Wood top and bottom rails with square balusters; solid railings of wood, fiber cement, or cut shingle siding or manufactured stone veneer.

Soffits and Porch Ceiling: Exposed rafters at soffits with starter board or v-groove sheathing; T&G wood, beaded plywood, exterior-grade plywood, or stucco porch ceiling.

Gutters: Ogee or half-round primed or prefinished metal. PVC is also acceptable in a color that matches the trim. Fascia gutter also permitted.

Downspouts: Rectangular or round primed or prefinished metal. PVC is also permitted in a color that matches the trim or stucco.

Shutters: Not applicable.

Chimneys: Stucco, brick, manufactured stone veneer, or siding to match house.

Front Yard Fences: Wood, stone, or masonry with stucco finish. Vinyl picket also permitted.

Rear Yard Fences: Cedar, redwood, or masonry with stucco finish (if applicable). Vinyl and pressure treated wood are also permitted.

Colors

Siding and Trim: Colors to be selected from the East Garrison Color Palette.

Windows: White or sashes to match trim color (see the East Garrison Color Palette).

Roof Shingles: Natural shake color, or selected from the East Garrison Color Palette.

Gutters and Downspouts: Match trim color.

Front Yard Fences: Wood is to be white; stucco finish to match house color.

Note: A color palette has been adopted and is available through the town architect.

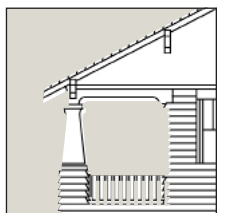

Garrison Craftsman



Simple massing and playful details characterize this Picturesque Camp house.



Simple trim details and three-quarter scale are characteristics of the Picturesque Camp style.



Vertical openings and a full, expressive porch create a lovely Picturesque Camp house.



Early Carpenter Gothic cottage from The Architecture of Country Houses by A.J. Downing



Essential Elements of Picturesque Camp

- 1 Steeply pitched, front-facing gable roofs.
- 2 Cut wood ornament, often with natural forms such as leaves and vines.
- 3 Clapboard or cut shingle siding.
- 4 Vertical proportions for windows and doors.
- 5 Box bay and cutaway bay windows.

History and Character

THE PICTURESQUE CAMP STYLE builds on the early Carpenter Gothic cottages built in the western region of the United States from early pattern books. While the style became fashionable in the 1800s in the Bay Area, its popularity grew and it spread north and south from San Francisco. The source of many early examples were the pattern books published by Andrew Jackson Downing. Publications such as *The Horticulturist* influenced the preferences of the public and provided an especially dramatic contrast to the inherited Spanish and adobe building types prevalent at the time. Many early religious camp settlements adopted the style with more and more exotic variations that included Eastlake, Queen Anne, and Italianate detailing.

The Picturesque Camp style is centered on simple, elegant forms to create more informal houses on small lots. This style has expressive porch elements, decorative trim elements, and vertical windows and doors.

Picturesque Camp



Illustrative Massing Diagrams

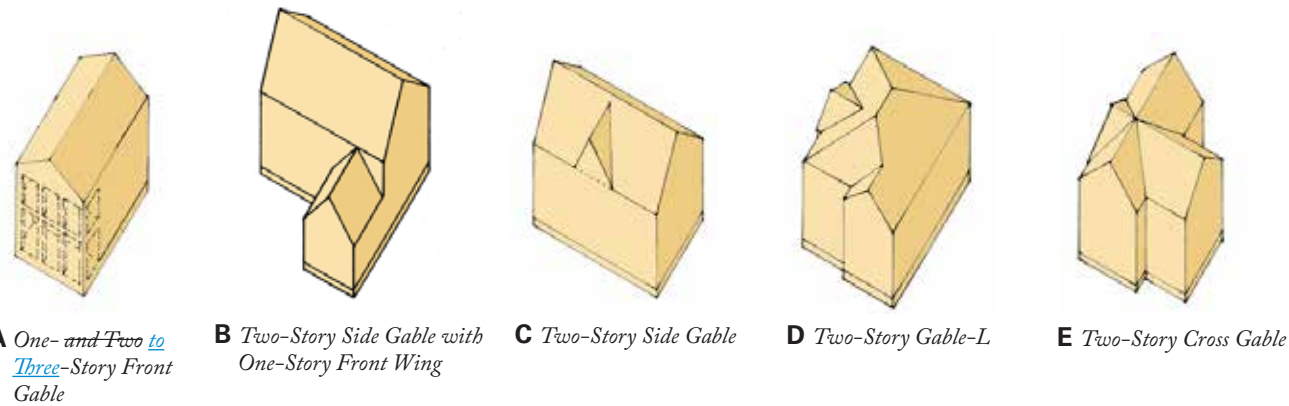

Picturesque Camp

Illustrative Massing Combinations

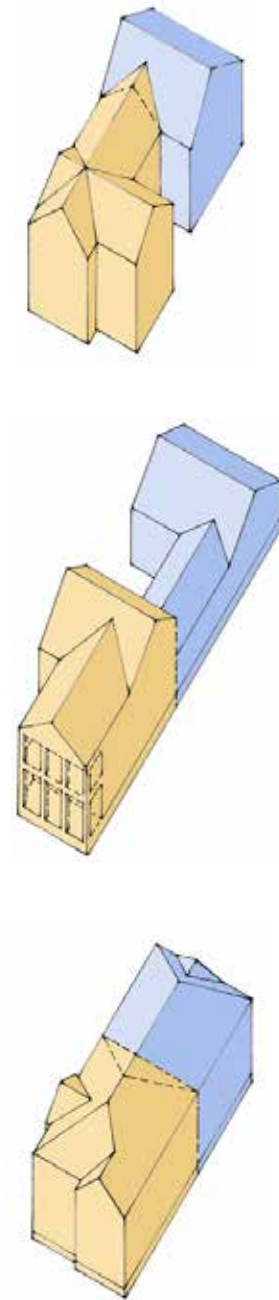

Massing and Composition

Massing

A One- to Three-Story Front Gable
 Rectangular volume with 8 to 12 in 12 roof pitch and gable facing the street. One-story partial, full, or wrapping front porch with shed or hip roof is common. Integral full front porches are also typical.

B Two-Story Side Gable with One-Story Front Wing

Rectangular volume with a one-story, 8 to 12 in 12 gabled wing facing the street. Multi-bay, shed porches extending from the wing across the length of the facade are common to this massing type. Single-bay shed porches attached to the wing are also acceptable.

C Two-Story Side Gable

Side-gabled rectangular volume, often with a steeply-pitched, gabled dormer flush to the front facade. Front gable roof pitch is typically 8 in 12 to 12 in 12, and the side gable is less steeply pitched, typically 6 to 10 in 12. One- or two-story front porches often extend across the full front of the house.

D Two-Story Gable-L

Two-story rectangular volume with hipped roof and a front gable which can extend beyond the front facade of the main body a maximum of 3 feet. Front gables are limited to 14 feet in width. The roof pitch is typically 8 to 12 in 12. A one- or two-story front wraparound porch with shed or hipped roof is most common.

E Two-Story Cross Gable

Two-story rectangular volume, with centrally-intersecting gable roofs. Front-facing gable roof pitch is typically 8 to 12 in 12, side-facing gable may be shallower, 6 in 12. One- or two-story, full-length, or wraparound front porch with shed or hipped roof.

Facade Composition

The facade composition is characterized by a symmetrical and balanced placement of doors and windows in regularly spaced bays that reflect the bays of the porch and projecting wings.

Combinations

Complex forms and larger living spaces may be created by combining side wings and/or rear wings with the main body. Gabled dormers may be added to introduce light into half-story and attic spaces. The architectural character of the attached parts should match that of the main body. Wings must also conform to all setback requirements (see *Community Patterns*).



Illustrative Partial Elevation and Section

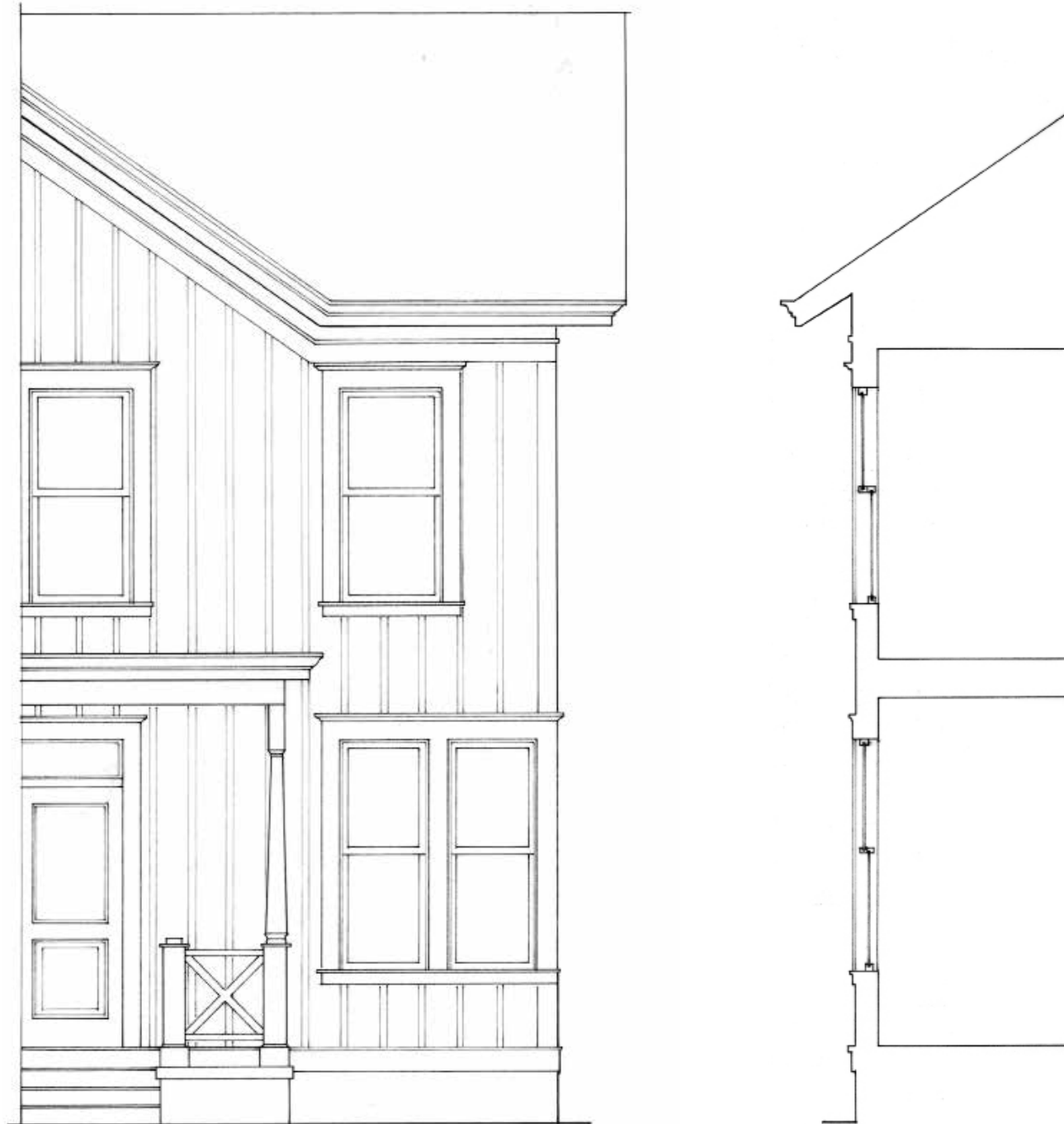

Eaves

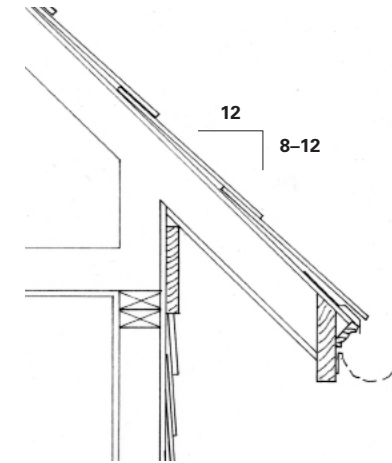

Optional Raked Soffit Section

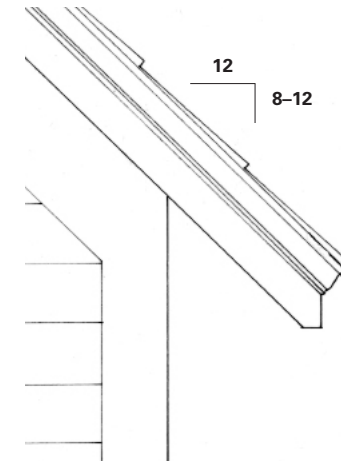

Optional Raked Soffit Elevation

Massing and Eave Details

Eave Details

Picturesque Camp is characterized by tall window proportions and steeply pitched roofs. Eaves are typically boxed on the slope of the rafters with a crown molding at the fascia and rake board. The roof pitch on most main bodies varies from 8 in 12 to 12 in 12. Pitches on gable ends facing the street in the gable-L forms are typically 8 to 12 in 12. Cut or ornamental shingles are often used in dormers and gables. Highlighted decorative trim, window sashes, and material changes are characteristics of this style.

Towers

A tower can be integrated with the massing to create third-floor living space or an outdoor room with views to the distance.

Finish Floor Elevation

The front door sill should be approximately 18 inches above the adjacent public sidewalk elevation. This may be accomplished by a raised foundation or through lot grading. In either case, front steps are required.



Optional simple or filigreed wood or wood-like gable details embellish Picturesque Camp rakes.

Illustrative Tower Configurations

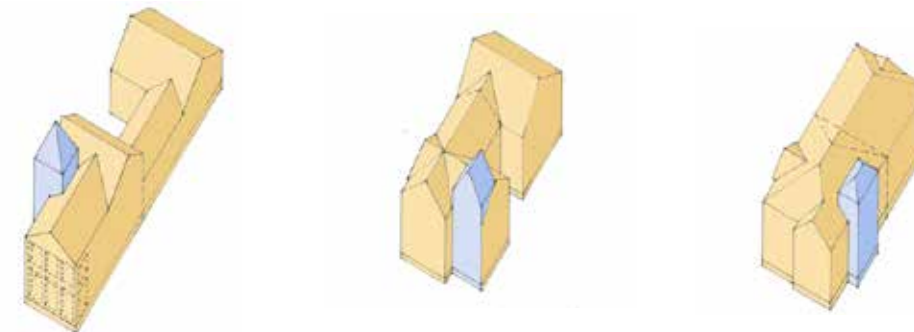

Picturesque Camp

Standard Windows

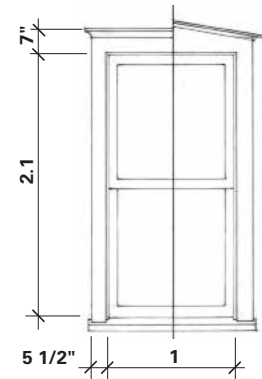

Second Floor

Note: Standard window dimensions represented by approximate proportion of width to height, depending on manufacturer. Trim dimensions represented by actual desired width.

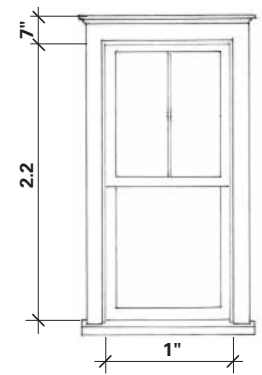

First Floor

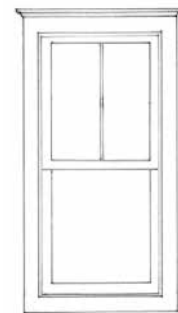
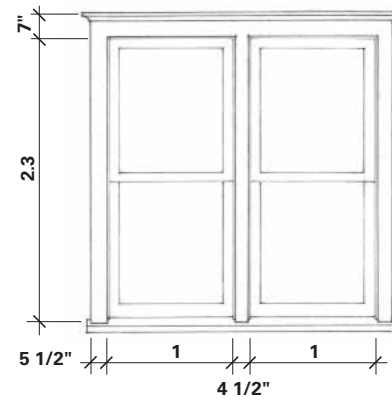

Alternate Trim Option



Playful trim details on Picturesque Camp windows



Optional box bay windows enhance Picturesque Camp houses.

Windows and Doors

Standard Windows

Windows are typically vertical in proportion. Basic window patterns are 1 over 1, 2 over 1, and 2 over 2, single- or double-hung with wide trim. Paired windows are often used in gable-L houses, or as accents where bay windows might also be used. Windows occasionally have a decorative cornice.

Standard Doors

Doors are centered in their bays and are either paneled or glazed. Double doors are often used, as well as single doors with sidelights and transoms.

Special Windows-Permitted Upgrade

Special windows include box bay and angled bay windows and small gable windows. Box bay and angled bay windows have a continuous base to the ground.

Trim

Windows and doors typically have a 5 1/2-inch-wide trim with a cap molding.

Shutters

Painted shutters, mounted with optional hardware as if operable, often occur on single windows. Shutter styles can either be paneled or louvered.

Special Windows-Permitted Upgrade

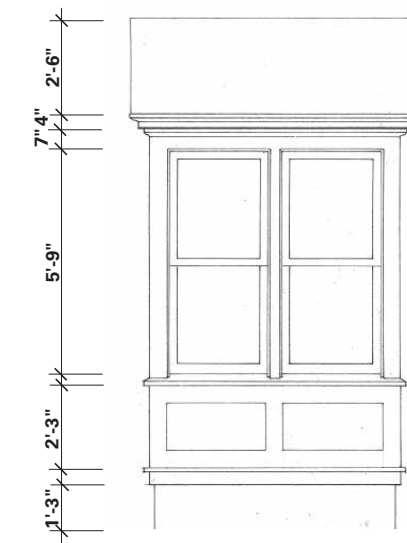

Box Bay

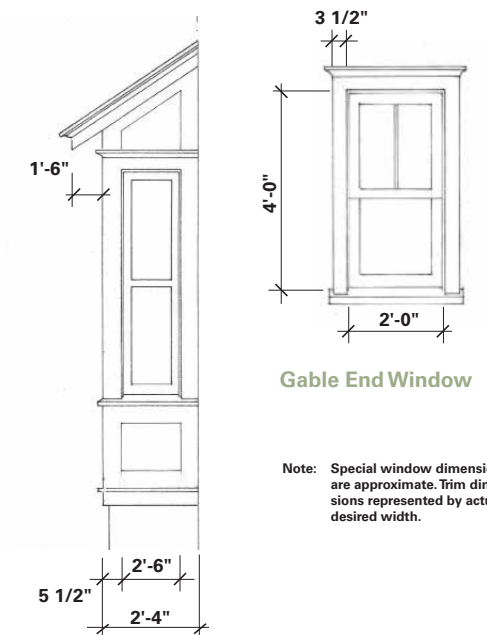

Gable End Window

Note: Special window dimensions are approximate. Trim dimensions represented by actual desired width.

Standard Door

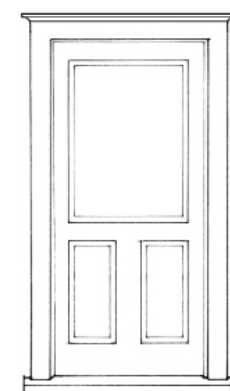

Special Doors-Permitted Upgrade

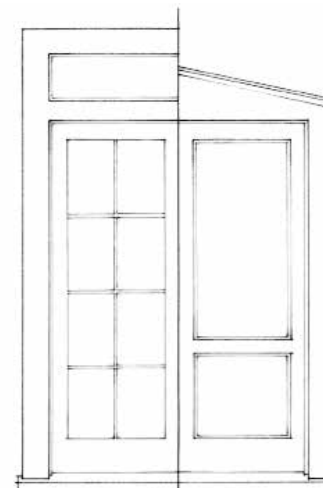
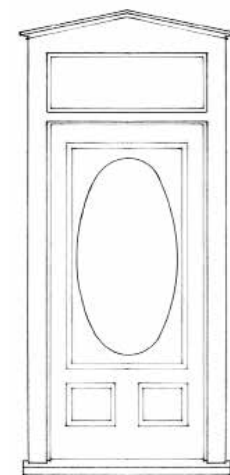
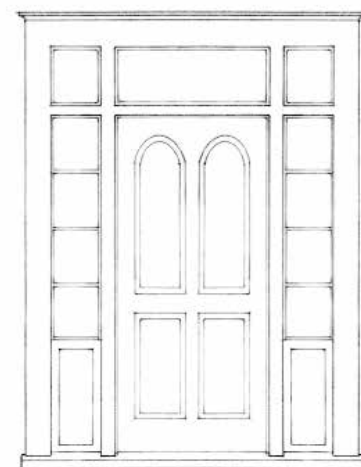

Picturesque Camp



Porch Placement Diagrams

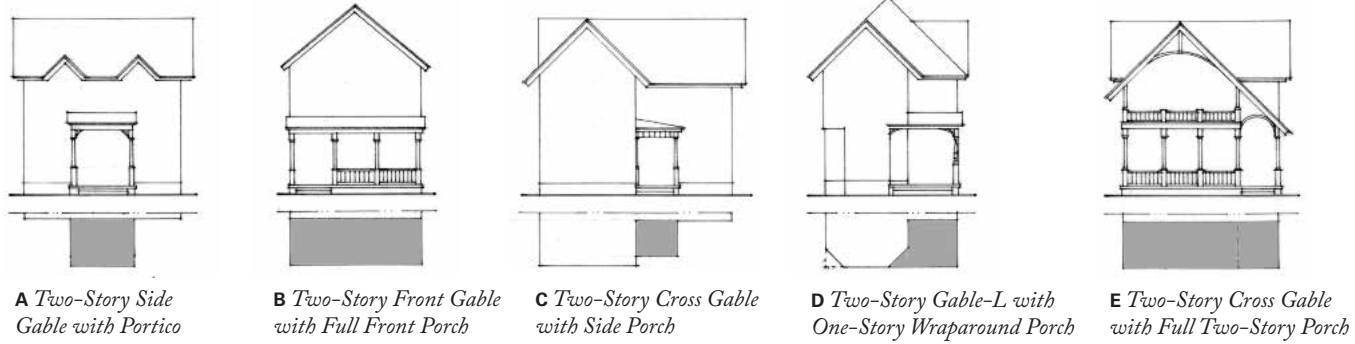

A Two-Story Side Gable with Portico **B** Two-Story Front Gable with Full Front Porch **C** Two-Story Cross Gable with Side Porch **D** Two-Story Gable-L with One-Story Wraparound Porch **E** Two-Story Cross Gable with Full Two-Story Porch



Illustrative one-story porch with deck



Illustrative two-story porch side elevation



Turned columns on porches create a lacy effect.

Illustrative Cornice Detail

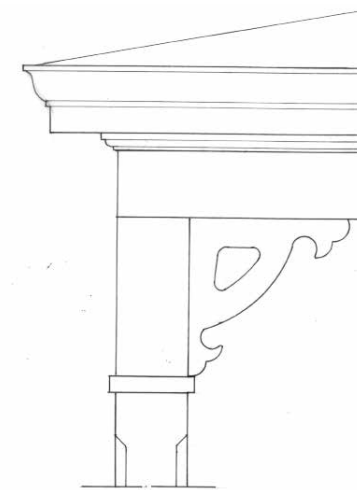

Porches

Porches can be one or two stories with either flat or shallow sloped roofs, except when fully engaged under a front-facing gable. Column types include a turned column or square columns with chamfered corners. Balusters can be either

turned, square, or scroll-cut ornament. Cut ornamental balusters are used primarily with square or turned columns. Optional entablatures are classically proportioned.

Illustrative Column Types

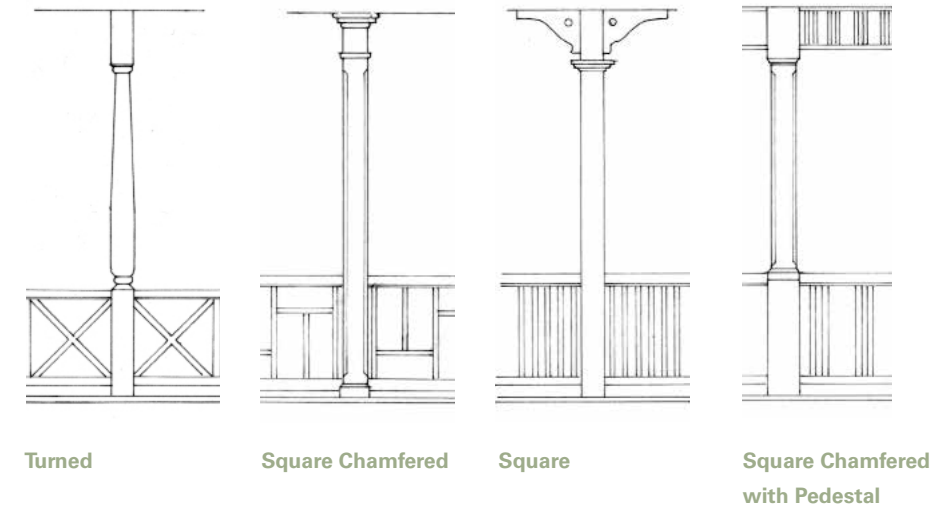

Illustrative Rail Details

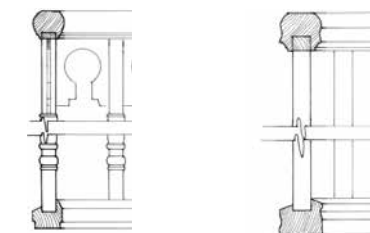

Picturesque Camp

Possibilities



Materials, Colors, and Possibilities

Materials

Siding: Board and batten, wood or fiber-cement clapboard.

Roofing: Composite shingles or flat concrete tile.

Windows: Single- or double-hung, energy-efficient wood, PVC-clad, cellular PVC, aluminum-clad, aluminum or vinyl with traditional wood profiles.

Trim: Wood, composition board, cellular PVC, or polyurethane.

Columns: Turned or built-up wood, or composite.

Railings: Wood top and bottom rails with straight, turned, or scroll cut balusters.

Soffits and Porch Ceiling: Fiber-cement board, plaster, T&G wood, beaded plywood, or exterior-grade plywood.

Gutters: Half-round primed or prefinished metal. PVC is also acceptable in a color that matches the trim. Fascia gutter also permitted.

Downspouts: Round primed or prefinished metal. PVC is also permitted in a color that matches the trim.

Shutters: Raised or flat paneled, louvered or plank, in wood or composite material, or a colored vinyl.

Chimneys: Manufactured stone or brick veneer or siding to match house.

Front Yard Fences: Wood picket, prefinished metal, or stone. Vinyl picket also permitted.

Rear Yard Fences: Cedar or redwood. Vinyl and pressure-treated wood are also permitted.

Colors

Siding, Windows, and Trim: Colors to be selected from the East Garrison Color Palette.

Roof: Black, dark gray, or brown.

Gutters and Downspouts: Match trim color.

Shutters: Black or a color selected from the East Garrison Color Palette.

Front Yard Fences: Wood is to be white or match trim color.

Note: A color palette has been adopted and is available through the town architect.



Picturesque Camp



The Mediterranean Revival style can incorporate a variety of siding materials.



Mediterranean Revival incorporates a mix of Spanish and Monterey motifs.



Many Mediterranean Revival houses possess a one-story projecting front wing to create a screened front yard.



Architect's rendering of Mediterranean Revival design in Pencil Points magazine, 1925



Essential Elements of the East Garrison Mediterranean Revival

- 1 Simple, straightforward volumes, sometimes with a gable wing facing the street.
- 2 Shallow sloped roofs, either hip or gable, with shingles and tile.
- 3 Simplified versions of Colonial windows and doors in an eccentric arrangement.
- 4 Multi-pane windows that are wide in proportion, usually with 4 over 4 or 6 over 6 pane patterns.

History and Character

THE MEDITERRANEAN REVIVAL STYLE, a hybrid style developed for East Garrison, draws on the distinctive architectural character of the Monterey Peninsula combined with the popular California Spanish Colonial style. Both variants date back to the early 19th century. The first revival started around 1925 amidst a very popular renaissance of Spanish architectural forms throughout the region. The Monterey and Spanish Revival houses of this period looked to their older California ancestors which were originally built in more open ranch environments. Over time, the elements of the styles and building types began to find their way into more urban locations, especially main street commercial buildings. The Monterey style emerged from Spanish adobe precedents that date between 1815 and 1860. These houses used Colonial window and door detailing borrowed from New England carpentry techniques and added a rustic timber porch with exposed rafters and joists. The roofs had a very shallow pitch either gabled or hipped and were covered with clay tiles or cut wooden shingles.

Mediterranean Revival buildings in East Garrison start with the essential characteristic of simple massing, then add balconies and front porches. The style's fundamental charm lies in the contrast of warm sunlight and cool shadows (light and shade), in the use of materials, in texture and color, and in austere simplicity.

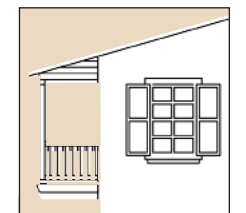

Mediterranean Revival

Illustrative Massing Diagrams

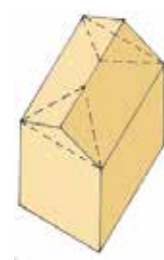

A Two-Story Front Gable

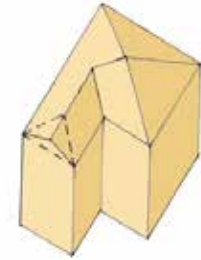

B Two-Story Narrow Gable-L

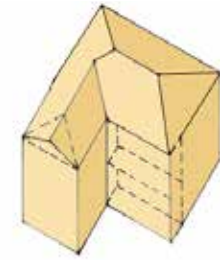

C Two-Story Gable-L



D Two-Story Basic

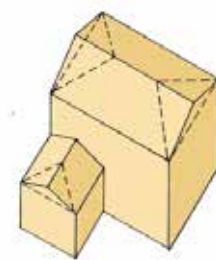

E Two-Story Basic with One-Story Front Wing

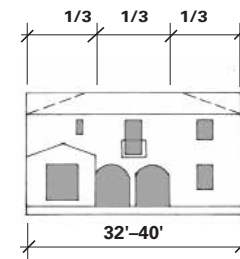
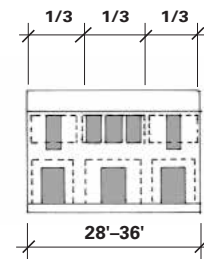
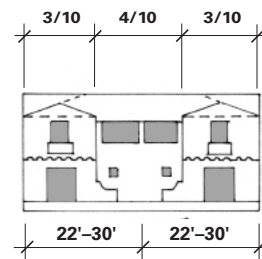
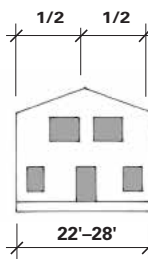
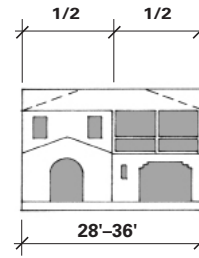
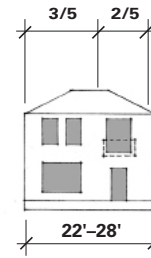
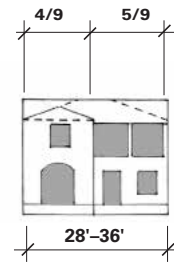
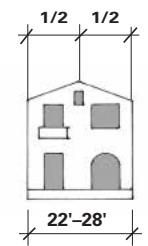
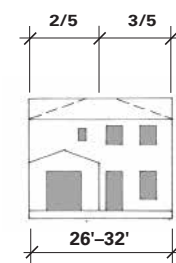
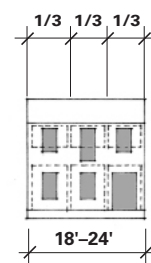
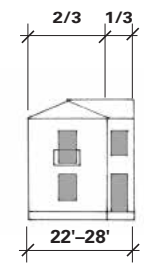
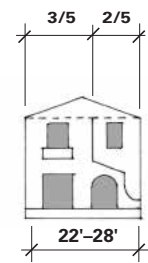
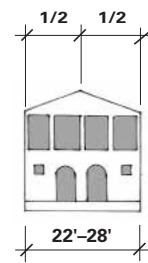

Illustrative Massing Combinations

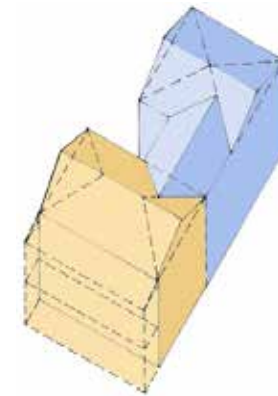
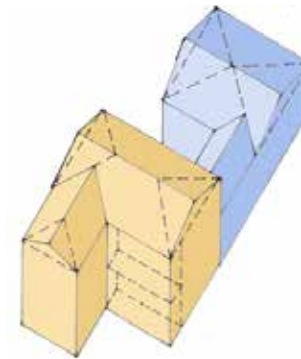
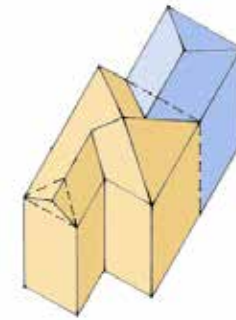

Massing and Composition

Massing

A Two-Story Front Gable

Two-story rectangular form with a 4 to 6 in 12 gabled roof pitch facing the street. A variety of porch and balcony options exist for this massing type.

B Two-Story Narrow Gable-L

Two-story main body, gable or hip roof facing the street with a 4 to 6 in 12 roof pitch. A two-story wing projects forward from the main body toward the street.

C Two-Story Gable-L

Cross-gabled volume with a 4 to 6 in 12 gable or hip facing the street. The width of the bay facing the street is typically two-fifths that of the main body. Cantilevered balconies are encouraged.

D Two-Story Basic

Rectangular volume with a 4 to 6 in 12 roof pitch and gable or hip parallel to the street. Second floor, full-front projecting balconies or two-story full-front porches are encouraged with this massing.

E Two-Story Basic with One-Story Front Wing

Rectangular volume with a one-story, 4 to 6 in 12 hipped or gabled wing facing the street. Inset porches are common in this massing type, however a single-bay shed porch can also be used.

Facade Composition

In Mediterranean Revival houses, most of the character is derived from a good use of proportion and spare, well-placed use of ornament. Although windows and doors are often placed asymmetrically, the overall composition is balanced.

Combinations

Complex forms and larger living spaces may be created by combining side and/or rear wings with the main body. The architectural character of the attached parts should match that of the main body.

Mediterranean Revival

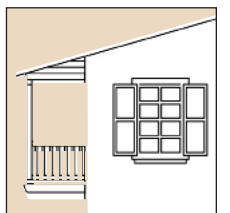

Illustrative Partial Elevation and Section



Optional Open Rafter Eave

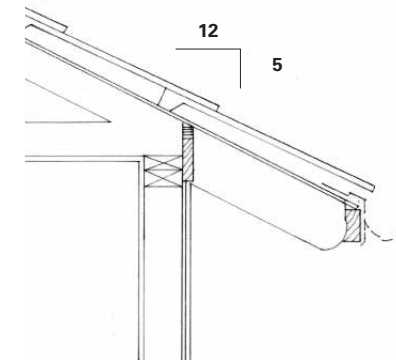

Massing and Eave Details

Eave Details

Second floor off-sets, where they occur, should create eight- to ten-inch overhangs. Shallow eaves should be constructed of building wall material, wood, or molded plaster.

Deep eaves should be constructed of wood sheathing supported by rafter tails at approximately 24 inches on center. Exposed rafter tails typically have shaped ends.



Exposed rafter tails add character to Mediterranean Revival eaves.

Towers

Towers are not permitted on Mediterranean Revival houses.

Finish Floor Elevation

The front door sill should be approximately 18 inches above the adjacent public sidewalk elevation. This may be accomplished by a raised foundation or through lot grading. In either case, front steps are required.



Flush face at rake focuses attention on the elevation.

Mediterranean Revival

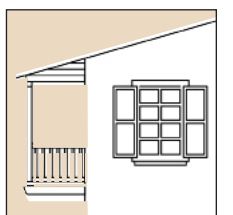

Standard Windows

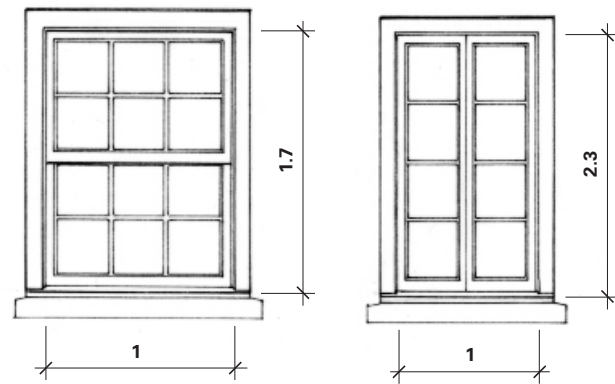

Note: Standard window dimensions represented by approximate proportion of width to height, depending on manufacturer.

Shutter Options

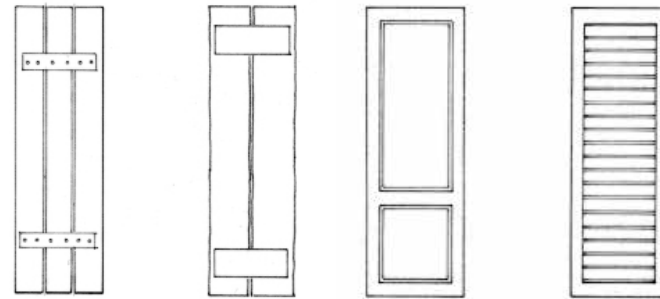

Windows and Doors

Standard Windows

There are two principal types of windows – casement windows and single- or double-hung windows. Both types are often mixed in the same house. Single- or double-hung windows are typically more horizontal in proportion with six-over-six muntin patterns and 5½" wide trim. Casement windows are typically paired with either four-pane patterns for narrow windows and eight-pane patterns for wider windows. These typically have only minimal trim and can also be recessed within a stuccoed, arched opening. In this condition, the window may either be rectangular or arch-topped.

Special Windows-Permitted Upgrade

Special windows include small square and arched windows. Decorative metal grillwork is sometimes used with the accent windows.

Shutters

Painted shutters are encouraged on single double-hung windows, single multi-paned doors, or with French doors. Shutters should be approximately equal to half the width of the window or single door. Shutters on double doors should equal the width of the door. Shutter styles can either be paneled or louvered. Optional shutter hinges add character.

Standard Doors

Doors include paneled types with four-, six- and multiple-panel patterns. Paired doors with either eight or ten large panes are typical on both the ground floor and off the balcony on the second floor. Single multi-paned doors, with either full-length pane patterns or Å-length pane patterns, are typical and are often used in combination with the solid panel door on a facade.

Special Windows-Permitted Upgrade

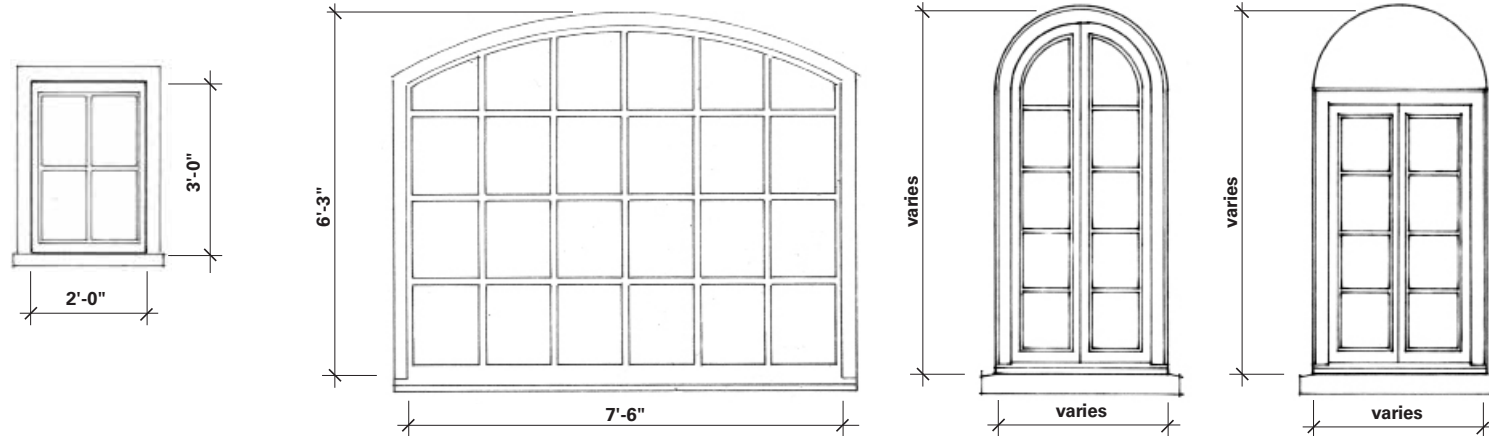

Note: Special window dimensions are approximate.

Standard Door

Standard Doors-Permitted Upgrade

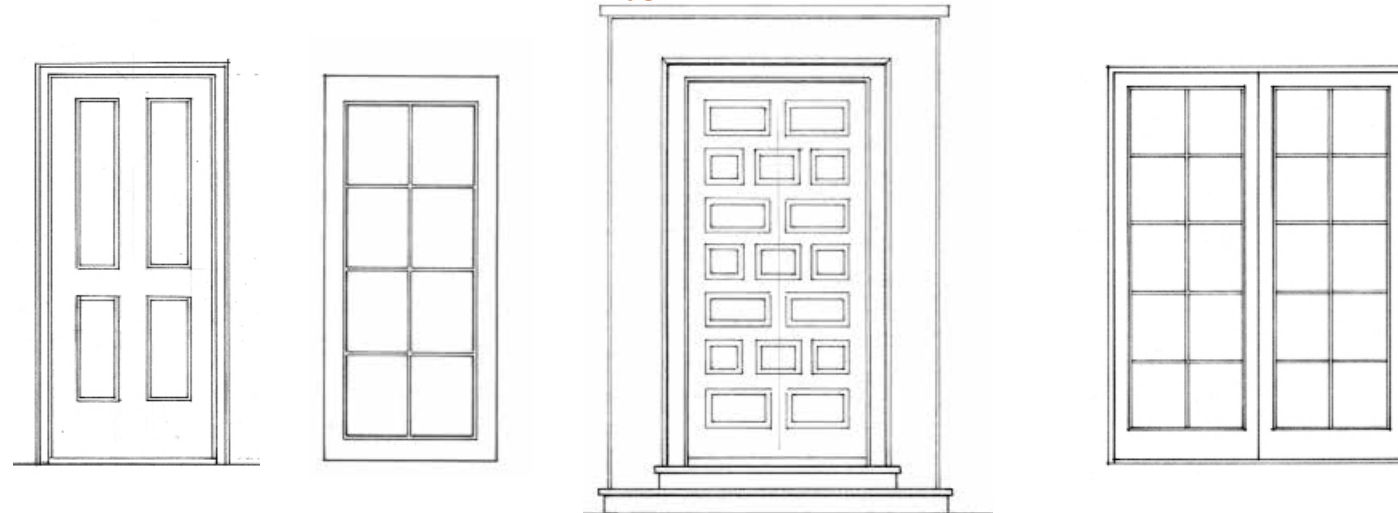

Shutters add dimension to Mediterranean Revival windows.

Mediterranean Revival

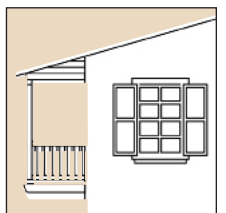

Porch Placement Diagrams



A Two-Story Front Gable with Second-Story Balcony

B Two-Story Gable-L with Two-Story Porch

C Two-Story Basic with Full Two-Story Porch

D Two-Story Gable-L with Two-Story Porch

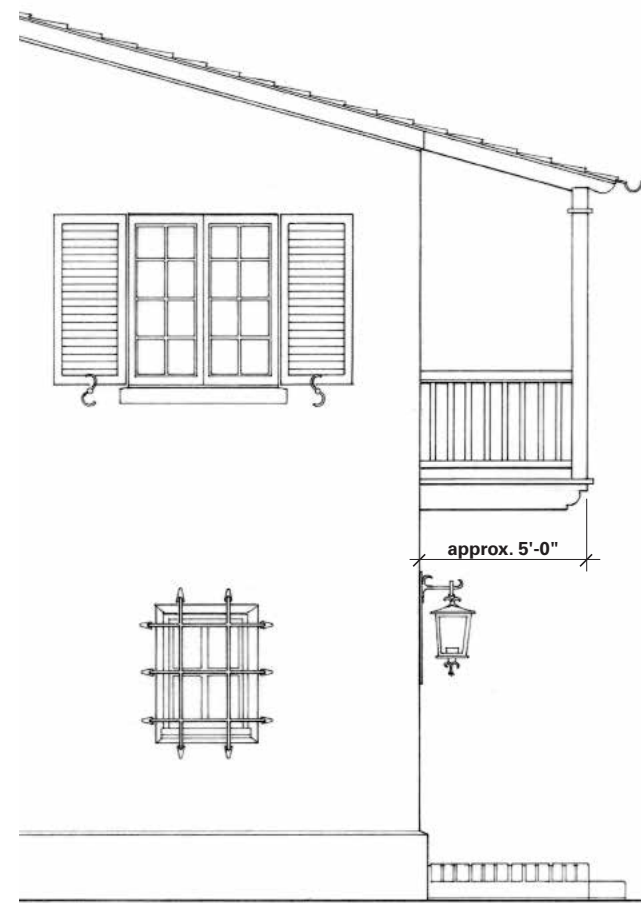

Side elevation with optional special window



Illustrative front elevation

Optional Balcony Types

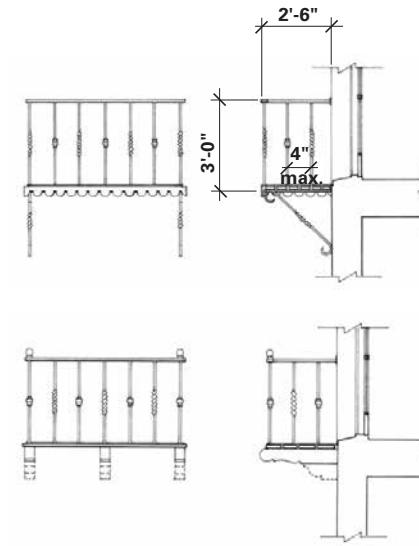

Illustrative Porch Detail

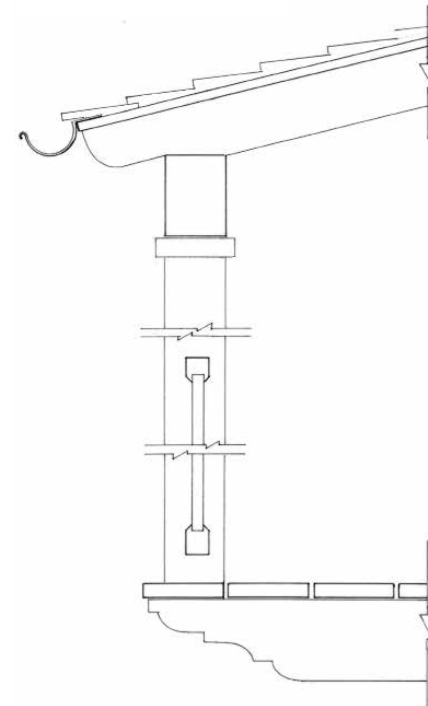

Porches

Porches are either designed as second-floor balconies that extend out from the main body approximately two-and-a-half to five feet, or as full two-story porches which are a minimum of six feet deep. Decorative wood joists and beams are visible from below. The railings are typically vertical wood or metal balusters.

The porch roof is a continuation of the main body roof, typically at the same slope. Rafter ends are typically exposed. Columns generally feature a stacked cap or a very simple capital trim and no base trim.



Mediterranean Revival houses often have second-story porches.

Illustrative Column Types

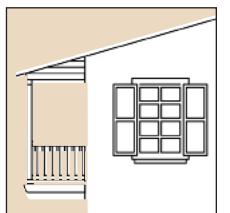
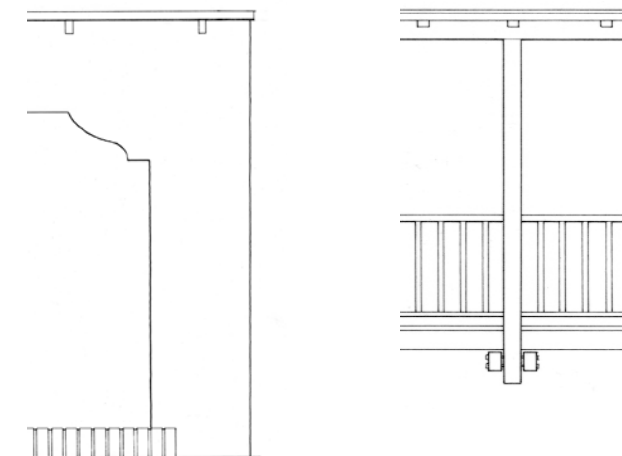

Mediterranean Revival

Possibilities



Attached Houses

Materials, Colors, and Possibilities

Materials

Siding: Stucco and optional second floor wood or fiber-cement clapboard. Lace finish not permitted.

Roofing: Concrete tile in flat or barrel profile, multiple stacked tile at eaves. Architectural asphalt shingle also permitted.

Windows: Single or double-hung, casement, and picture units, energy-efficient wood, PVC clad, aluminum-clad, cellular PVC, aluminum or vinyl with traditional wood profiles.

Columns: Wood or composite.

Balconies: Wrought-iron, solid-stock metal with a wrought iron appearance, wood, or corbelled plaster with metal railings.

Railings: Wood top and bottom rails with square or turned balusters.

Eaves: Starter board or v-groove sheathing.

Exterior Ceilings: Plank and beam or stucco.

Gutters: Half-round metal or PVC. Fascia gutter also permitted.

Downspouts: Round metal or PVC.

Shutters: Raised or flat panel, louvered, or plank, in wood or composite material or a colored vinyl.

Chimneys: Stucco.

Front Yard Fences: Masonry with stucco finish, wrought iron accents permitted. Wrought iron or aluminum also permitted.

Rear Yard Fences: Cedar or redwood, or masonry with stucco finish. Vinyl and pressure-treated wood are also permitted.

Colors

Stucco: White, ivory, buff, or tan (refer to the East Garrison Color Palette).

Roof Tiles: Variegated colors.

Windows: Sashes and frames to be dark stain or paint; or bright, pure paint colors (refer to the East Garrison Color Palette).

Trim/Shutters: Dark stain or paint; or bright, pure paint colors (refer to the East Garrison Color Palette).

Gutters: Match color of eaves.

Downspouts: Match color of stucco.

Walls/Fencing: Stucco to match house body. Wrought iron to be matte brown/black, rust red, or antiqued black.

Note: A color palette has been adopted and is available through the town architect.

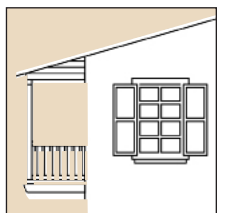

Mediterranean Revival



A simple symmetrical house with a robust portico



The facade composition and classically detailed porch make this a good example of the Garrison Revival style.



This house is an example of the massing and composition characteristic of Garrison Revival houses.



Early twentieth century Colonial Revival house rendering

A.L. Gupitt, 1920



Essential Elements of Garrison Colonial Revival

- 1 Simple, straightforward volumes with projecting wings and porches added to make more complex shapes.
- 2 An orderly, symmetrical relationship between windows, doors, and building mass.
- 3 Simplified versions of classical details and columns, occasionally with classical orders used at the entry.
- 4 Multi-pane windows.
- 5 Strong horizontal lines emphasized by broad eaves and wide trim.

History and Character

THE GARRISON REVIVAL is based on Colonial Revival styles that were prevalent throughout the country in the early 1900s. The Colonial Revival style is evident in many California towns and cities with regional precedents found in places like Monterey, Salinas, Spreckels, and Hollister.

The Colonial Revival style is based on classical design principles followed during the colonial period in this country. The interpretations, however, often reflect regional adaptations. The California examples include many houses with full front porches as well as Dutch Colonial renditions. Cornices are often deep, with extended overhangs and brackets on both the main body of the house and the porches.

The houses are composed of simple forms with well-proportioned windows and door surrounds. These are often more horizontal in appearance with special windows appearing in the center of the house over the front door. Garrison Revival houses will emphasize the horizontal proportions with square, robust columns, wide corner boards, pilaster expressions, and door and window trim.

Garrison Revival

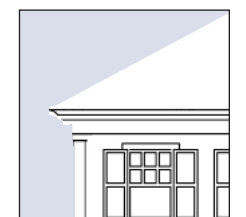

Illustrative Massing Diagrams

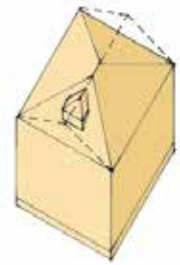

A Two- to Three-Story Narrow

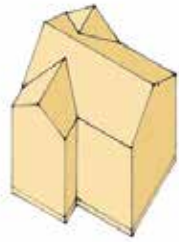

B Two-Story Cross Gable

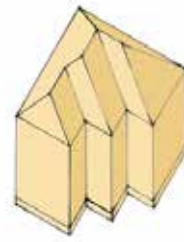

C Two-Story Gable-L

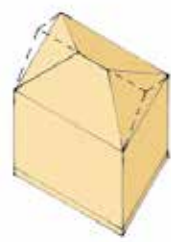

D Two-Story Basic

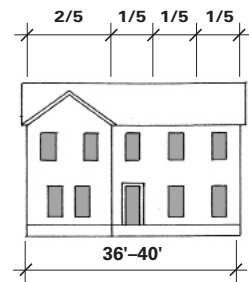
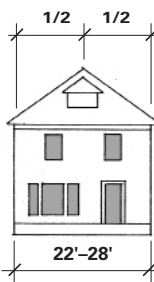
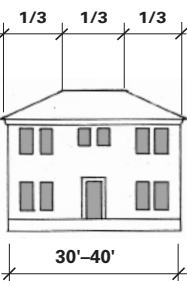
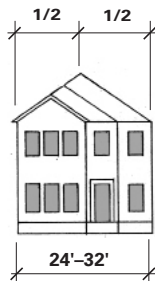
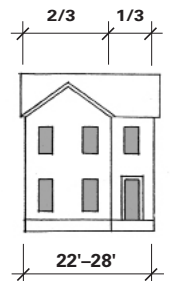
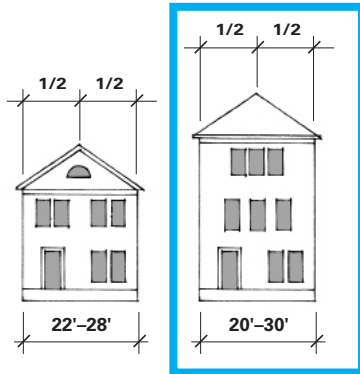
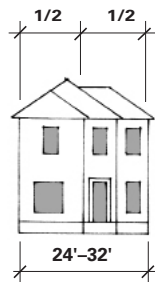
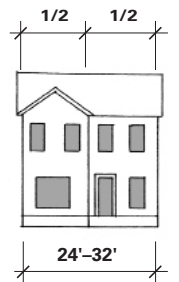

Illustrative Massing Combinations

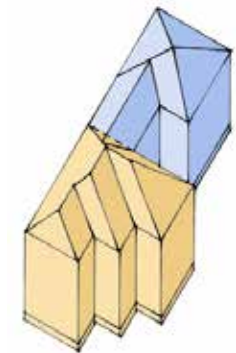
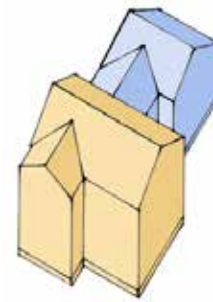
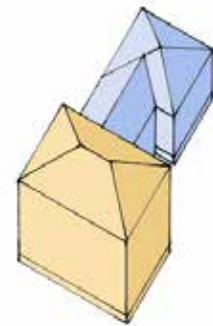

Massing and Composition

Massing

A Two- to Three-Story Narrow

Front-gabled or hipped rectangular volume. Roof pitch is typically 5 to 8 in 12 for gabled volumes and 4 to 7 in 12 for hipped volumes. Gabled- or hipped-front porches are common. Porches may be either one- or two-story.

B Two-Story Cross Gable

Cross-gabled volume with a 5 to 8 in 12 gable facing the street. The width of the gable facing the street is typically one-half to two-thirds the width of the main body for houses up to 32 feet wide, and two-fifths that of the main body for houses 36 feet and over. This massing typically accommodates a continuous porch with shed roof located between the legs of the L.

C Two-Story Box-L

Hipped or side-gabled volume with a 4 to 8 in 12 pitch with intersecting front and side wings. The front-facing wing may either be gabled with a 5 to 8 in 12 pitch or hipped with a 4 to 7 in 12 pitch. The relationship of the front wing is typically two-thirds the width of the main body with the side wing projecting an equivalent amount to create a nesting effect. This massing typically accommodates a porch with a shed roof wrapping the main body between the two wings.

D Two-Story Basic

Hipped or side-gabled rectangular volume. Roof pitch is typically 5 to 8 in 12. One-story temple front or hip front porches, placed symmetrically on the front facade. Two-story center porches are also permitted. Porches are most often one-fifth the length of the main body, and, occasionally, three-fifths or the entire length of the front facade.

Facade Composition

Garrison Revival facade composition is characterized by a symmetrical and balanced placement of doors and windows. Standard windows most often occur as singles, or in pairs. Entrance doors are generally located in the corner of narrow houses and the center of wide houses.

Combinations

Complex forms and larger living spaces may be created by combining side and/or rear wings with the main body. The architectural character of the attached parts should match that of the main body. Wings must also conform to all setback requirements (see *Community Patterns*).

Garrison Revival

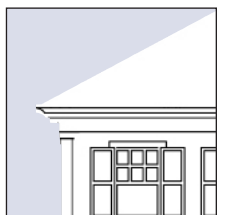

Illustrative Partial Elevation and Section



Eaves



Optional Gable End Return

Massing and Eave Details

Eave Details

The Garrison Revival is characterized by the broad proportion of the window and door elements. Windows are often paired and are relatively wide in comparison to their height. The cornice of the Garrison Revival is characterized by a deep eave, often flat, occasionally with wide but shallow brackets spaced two to three feet apart. There is always a frieze board below the soffit.

Towers

A tower can be integrated with the massing to create third-floor living space or an outdoor room with distant views.

Finish Floor Elevation

The front door sill should be approximately 18 inches above the adjacent public sidewalk elevation. This may be accomplished by a raised foundation or through lot grading. In either case, front steps are required.

Illustrative Tower Configurations

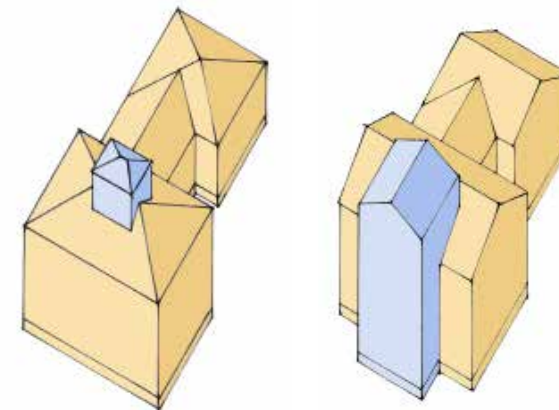

Garrison Revival

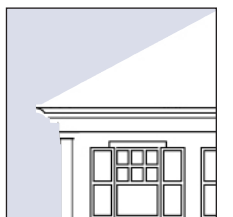

Standard Windows

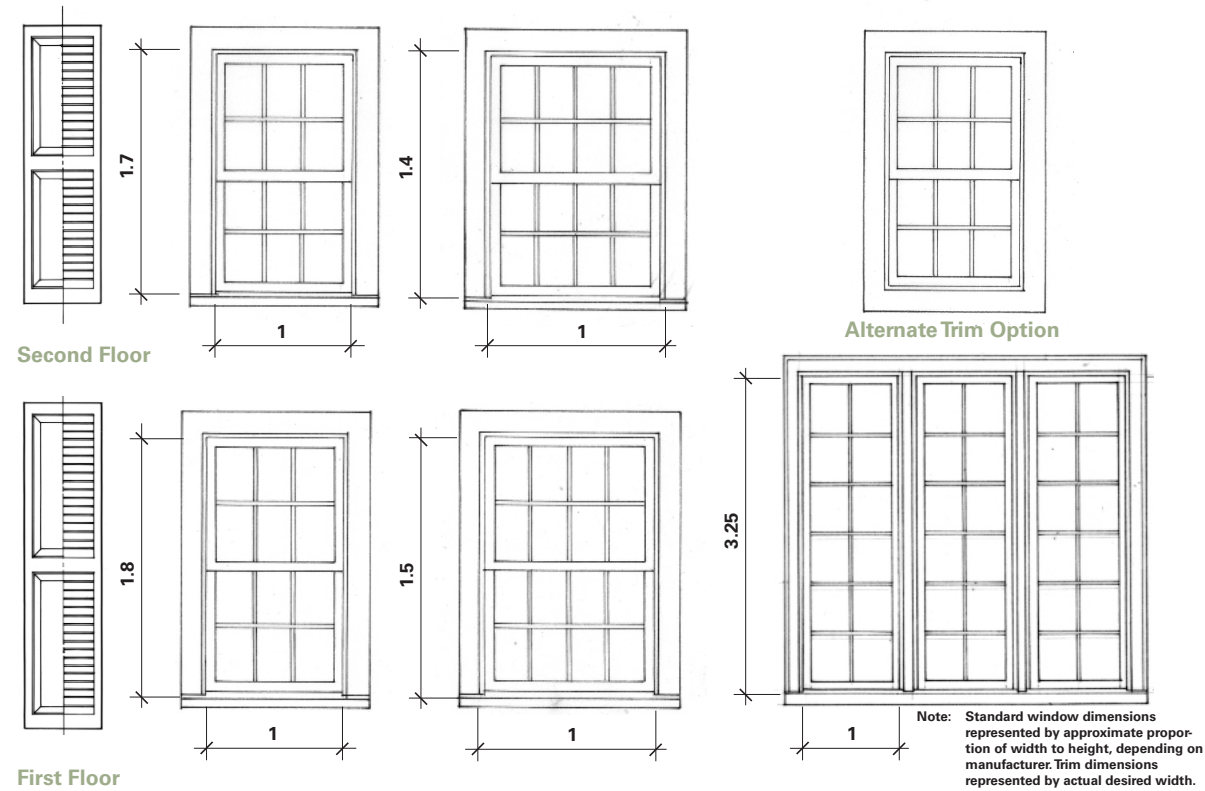

Special Windows-Permitted Upgrade

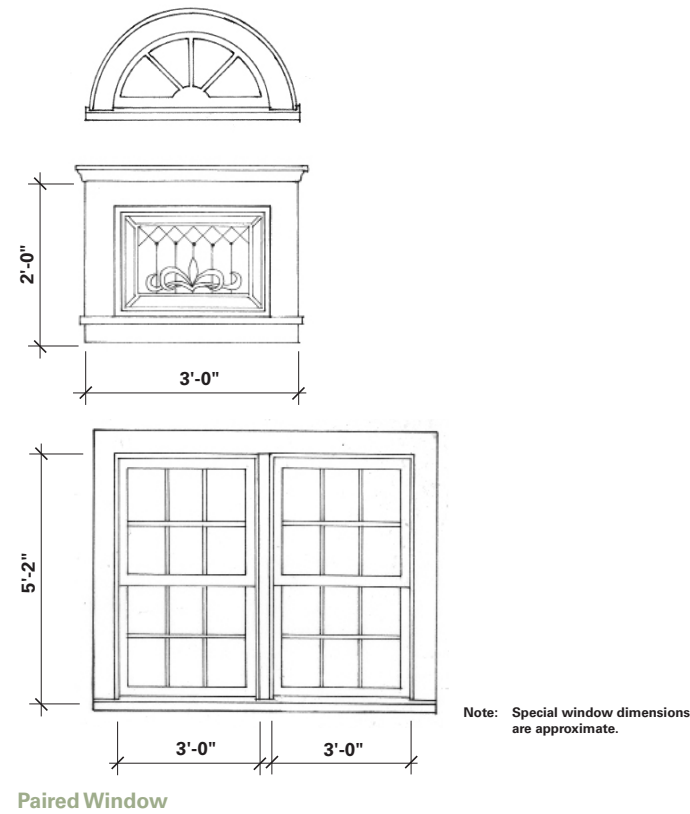

Windows and Doors

Standard Windows

Window openings are typically horizontal in proportion. Single windows are typically wide, single- or double-hung with 8 over 8 patterned sash. Paired and triple windows are either single- or double-hung with 6 over 6 patterned sash or tall casement windows at the first floor. Casement windows in groups of two or three on the first floor are encouraged for Garrison Revival houses.

Special Windows-Permitted Upgrade

Special windows include small square, rectangular, and round-top windows which are often located in a front gable or in various combinations over the entry door.

Standard Doors

Doors are typically six-panel, either single or paired. Single doors can have sidelights in addition to a transom.

Trim

Windows and doors typically have 5½-inch-wide trim. First floor windows often have a cap molding.

Shutters

Painted shutters are recommended on single windows. Shutter styles can either be paneled or louvered. As an option, shutters may be sized and mounted with hardware as if operable.



Transoms and sidelights lend formality to front doors.

Standard Door

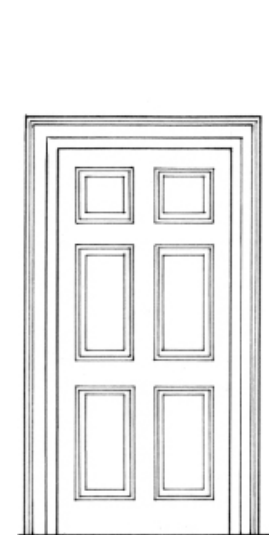

Special Doors-Permitted Upgrade



Garrison Revival

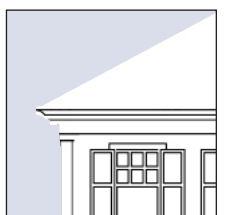

Porch Placement Diagrams

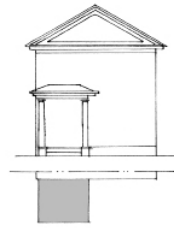

A *Two-Story Narrow with Side Portico*

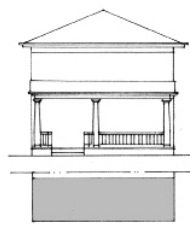

B *Two-Story Narrow with Full Front Porch*

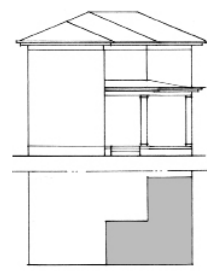

C *Two-Story Gable-L with Wraparound Porch*

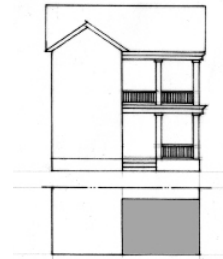

D *Two-Story Cross Gable with Two-Story Porch*

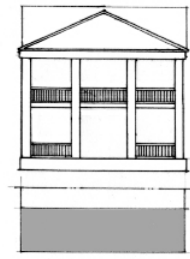

E *Two-Story Temple Front Porch*

Illustrative Porch Elevations



Illustrative Rail Details

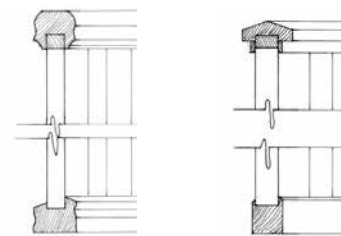

Porches

Porches can be one or two stories with either flat or shallow hipped roofs. Column types include 10- and 12-inch-diameter Tuscan and Doric order columns and 8- to 12-inch-square box columns. Balusters can be turned, but are more typically square.

Column heights are approximately nine feet for the first floor of a two-story porch and eight to nine feet for a single-story porch. Temple front porches typically have classically proportioned entablatures with a 6 in 12 or 8 in 12 roof pitch. Shed or hip porches typically have a 2 to 4 in 12 pitch.



One-story porches range from the casual to the formal.



Illustrative Column Types

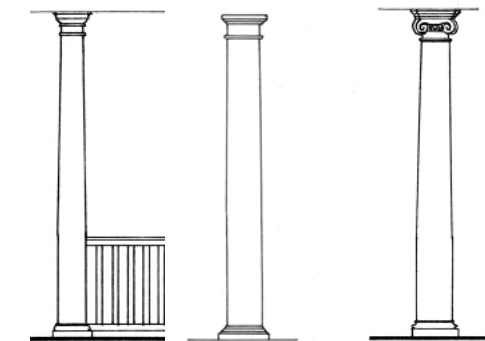

Tuscan and Doric

Tapered and Square Box

Ionic

Garrison Revival

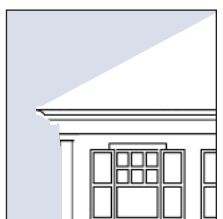

Possibilities



Attached Houses

Materials, Colors, and Possibilities

Materials

Siding: Fiber-cement clapboard or stucco. Lace finish not permitted.

Roofing: Composition shingles or concrete tile with flat profile.

Windows: Single- or double-hung and casement, energy-efficient wood, PVC-clad, cellular PVC, aluminum-clad, aluminum or vinyl with traditional wood profiles.

Trim: Stucco, wood, composition board, cellular PVC, or polyurethane.

Columns: Wood, or composite with Classical entasis and proportions in the Tuscan, Doric, and Ionic orders.

Railings: Wood top and bottom rails with square wood balusters.

Soffits and Porch Ceiling: Fiber-cement board, plaster, T&G wood, beaded plywood, exterior-grade plywood, or stucco.

Gutters: Ogee or half-round primed or prefinished metal. PVC is also acceptable in a color that matches trim. Fascia gutter also permitted.

Downspouts: Rectangular or round primed or prefinished metal. PVC is also permitted in a color that matches trim or stucco.

Shutters: Raised or flat paneled, louvered or plank, in wood or composite materials or a colored vinyl.

Chimneys: Stucco, brick, or manufactured stone veneer or siding to match house.

Front Yard Fences: Painted wood, prefinished metal, stone, masonry, or stucco finish (if applicable). Vinyl picket also permitted.

Rear Yard Fences: Cedar or redwood, or masonry with stucco finish. Vinyl and pressure-treated wood are also permitted.

Colors:

Siding, Windows, and Trim: Colors to be selected from the East Garrison Color Palette.

Roof: Black, dark gray, or dark brown.

Gutters and Downspouts: Match trim color.

Windows: White.

Shutters: White, black or a color selected from the East Garrison Color Palette.

Fencing: Wood is to be white, metal to be black, and stucco to match house body.

Note: A color palette has been adopted and is available through the town architect.

Garrison Revival

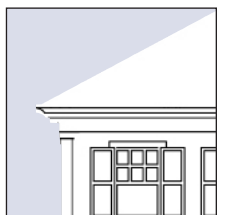



View of the mixed-use Town Center

Essential Elements of East Garrison Mixed-Use Buildings

- 1 Ground floors have storefront design with large windows and glass doors.
- 2 Three- and four-story buildings with individual expression at storefront level.
- 3 Simple, individual window compositions above the ground floor with vertically proportioned, double-hung sashes.
- 4 Front facades have parapet walls with cornice expression.

Character

ANCHORING THE TOWN CENTER IS a mixed-use building with primarily commercial uses on the ground floor and apartments above. The building's facade will be articulated in a simplified expression of the Spanish Revival style and subdivided to look like a series of individual buildings. This approach complements the traditional surrounding architectural styles while breaking down the building's scale.

Storefronts will line the ground floor facing Sherman Avenue to support a main street appearance. Terraces adjacent to wide sidewalks will accommodate outdoor dining and merchandising, activating the park frontage. A pedestrian connection through the center of the building is designed to link the parking lot to the Town Square Park. The building will include public restrooms for use by park users and Town Center visitors.

Illustrations on the following pages provide examples of the envisioned exterior character.



Town Center

Architecture



View of Mixed-Use Building Concept from the corner of Ord Avenue and Sherman Boulevard

Town Center



Architecture



Ord Avenue Concept Elevation



Sherman Boulevard Concept Elevation



Town Center



Conceptual Building Elements



Four-Story Corner

Balconies, corner windows and a tower form anchor the intersection of Ord and Sherman, providing elements of human and civic scale opposite the park.

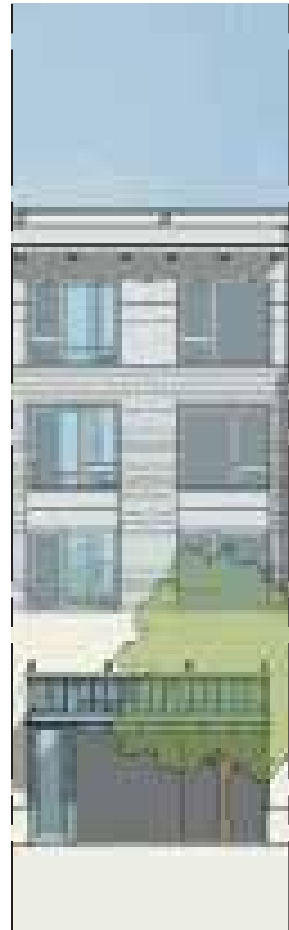

Four-Story Interior Bays

Changes in plane, cladding material, and color organize the town center building horizontally and vertically, visually breaking down the building into smaller elements.



Mid-Block Transition

The building transitions from four to three stories at the center of the block across a generous separation, providing pedestrian access to the block interior.



Three-Story Interior Bays

Parapets, chimney forms, and pergolas animate the roofline of the west half of the town center building while maintaining a consistently lower overall height along the park frontage.

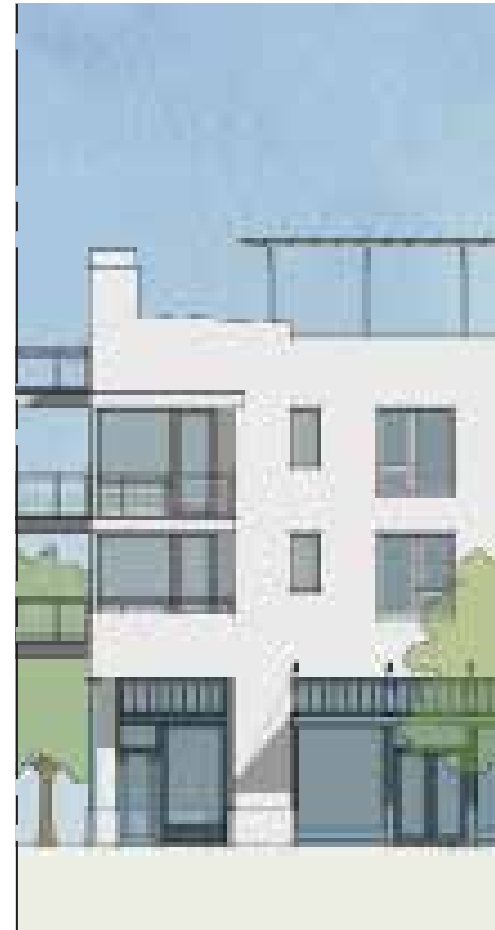

Three-Story Corner

The west corner of the town center is marked by a slender tower on-axis with the approach from the north on East Garrison Drive.



Town Center



Building Tenant Identification

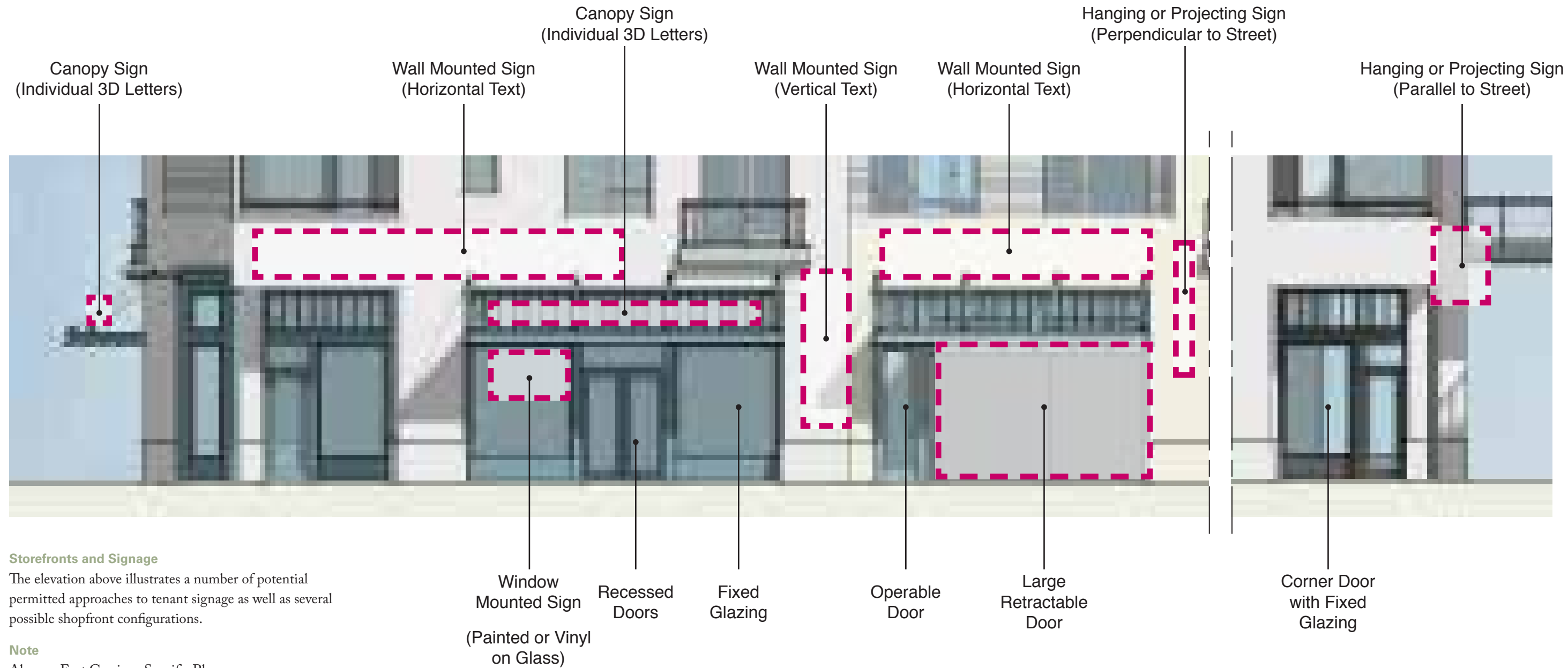

Storefronts and Signage

The elevation above illustrates a number of potential permitted approaches to tenant signage as well as several possible shopfront configurations.

Note

Also see East Garrison Specific Plan Section 3.5.9 Sign Regulations

Town Center





Simple, yet grand, facade composition in Santa Barbara.



Public buildings in the East Garrison Mediterranean Revival style may have a variety of roof heights and scales of openings.



Tower elements can be used to signify the importance of a public structure.



Even single-story buildings, when symmetrically arranged, can have a significant community presence.



Essential Elements of East Garrison Community Facilities

- 1 Monolithic wall architecture is arranged into a series of volumetric forms.
- 2 Windows and doors are composed in groups of localized symmetry.
- 3 Bracketed or sculpted cornice lines are common.
- 4 Entry doors are often emphasized by elaborate surrounds.

Character

WHILE THE ORIGIN OF THE SPANISH STYLE in this region was spiritual architecture, it was quickly adapted to all types of public buildings. In East Garrison, all community facilities will find their precedents in the Spanish Revival tradition, specifically among the civic and institutional buildings in the region some of which are pictured on this page. These precedents will be used to inspire all new public facilities at East Garrison including the new library, the fire station and parks and recreation facilities.

Buildings will be characterized by a white-washed wall architecture with variety in the scale and shape of windows and doors. Bell towers, elaboration around entrances, and detailing along the cornice lines can spice up this relatively unadorned style.

Community Facilities



Illustrative Fire House Elevation



Illustrative Library Elevation

Materials, Colors, and Possibilities

Materials

Siding: Stucco and optional second floor wood or fiber-cement clapboard. Lace finish not permitted.

Roofing: Concrete tile in flat or barrel profile, multiple stacked tile at eaves.

Windows: Single or double-hung, casement, and picture units, energy-efficient wood, PVC clad, aluminum-clad, cellular PVC, aluminum or vinyl with traditional wood profiles.

Columns: Wood or composite.

Railings: Wood top and bottom rails with square or turned balusters.

Eaves: Starter board or v-groove sheathing.

Exterior Ceilings: Plank and beam or stucco.

Gutters: Half-round metal or PVC. Fascia gutter also permitted.

Downspouts: Round metal or PVC.

Shutters: Raised or flat panel, louvered, or plank, in wood or composite material or a colored vinyl.

Chimneys: Stucco.

Colors

Stucco: White, ivory (refer to the East Garrison Color Palette).

Roof Tiles: Variegated colors.

Windows: Sashes and frames to be dark stain or paint; or bright, pure paint colors (refer to the East Garrison Color Palette).

Trim/Shutters: Dark stain or paint; or bright, pure paint colors (refer to the East Garrison Color Palette).

Gutters: Match color of eaves.

Downspouts: Match color of stucco.

Walls/Fencing: Stucco to match building. Wrought iron to be matte brown/black, rust red, or antiqued black.

Note: A color palette has been adopted and is available through the town architect.

Community Facilities

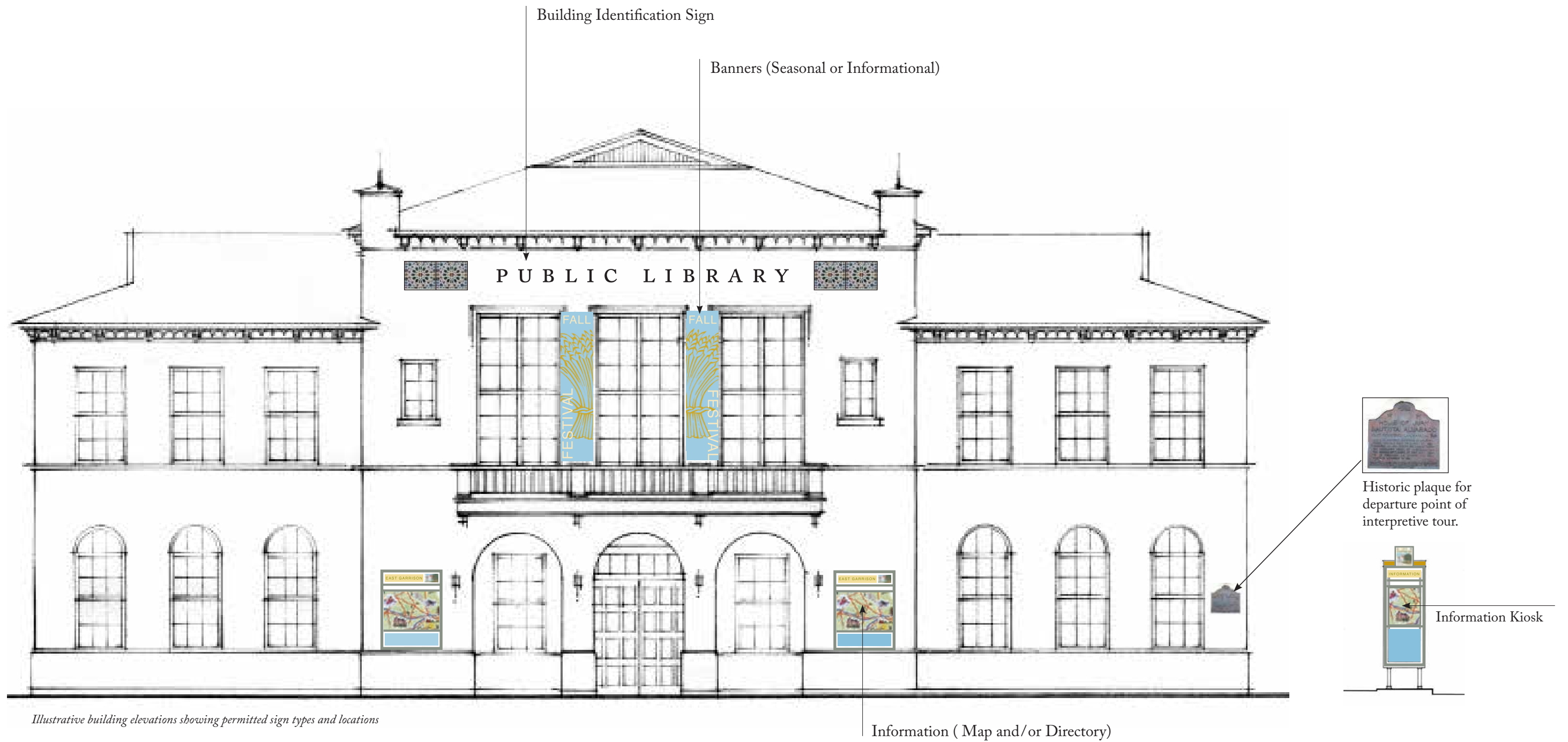

Community Facilities – Building Identification and Wayfinding



View of mixed-use building

Live/Work Rowhouses



Character

LIVE/WORK ROWHOUSES will complement ground floor commercial and cultural uses in the Town Center. The building facades shall be articulated in a mix of the Mediterranean Revival and Craftsman styles. Storefronts will line the ground floor facing the Town Square park to support a main street appearance. A pedestrian connection between buildings will link interior units to Meade Way.

Essential Elements

- 1 Ground floor storefront articulation facing the town square
- 2 Architectural character based on the traditional East Garrison architectural styles.
- 3 Blend of a minimum of two styles.
- 4 Punched window openings on upper floors.
- 5 Separate storefront entrance for storefront units.

Facade Kit-of-Parts



Mediterranean Revival (Narrow Lot)



Craftsman (Narrow Lot)



Mediterranean Revival (Wide Lot)



Craftsman (Wide Lot)



Mediterranean Revival (Wide Lot)



Mediterranean Revival (Wide Lot)



Craftsman (Wide Lot)



Mediterranean Revival (Wide Lot)

Live/Work Rowhouses



Conceptual 4-unit elevation



Conceptual 5-unit elevation



Conceptual 6-unit elevation



Live/Work Rowhouses Mediterranean Revival



Conceptual 4-unit elevation



Conceptual 5-unit elevation



Conceptual 6-unit elevation



Live/Work Rowhouses Craftsman

Storefronts and Signage

The elevation above illustrates a number of potential permitted approaches to tenant signage as well as several possible shopfront configurations for L-W units.

Note

Also see East Garrison Specific Plan
Section 3.5.9 Sign Regulations

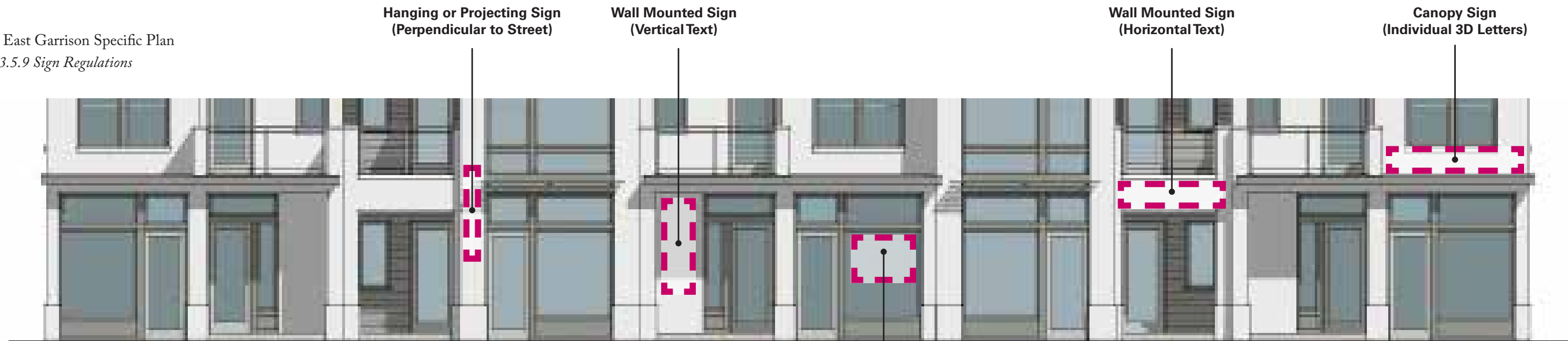

Conceptual 5-unit Storefront East Garrison Mediterranean Revival Elevation

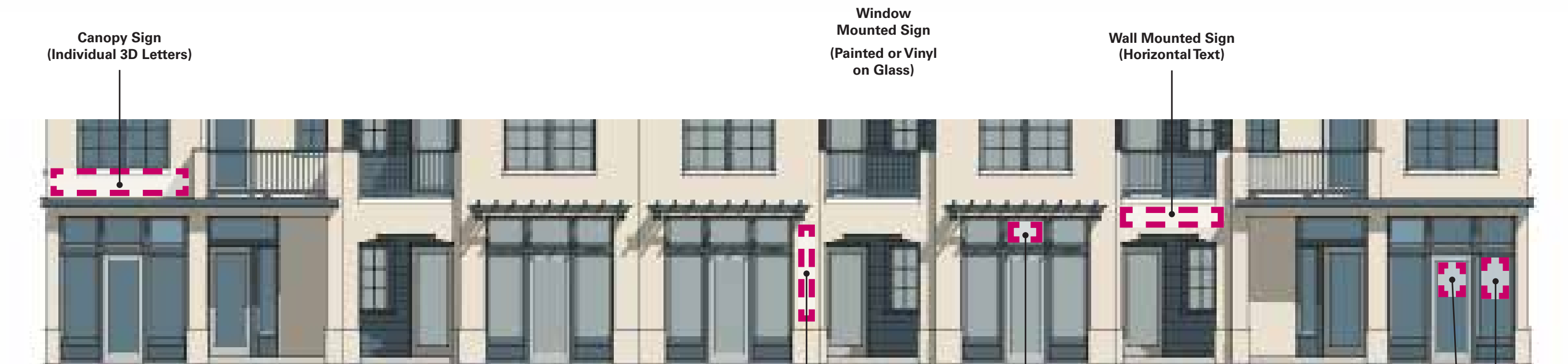

Conceptual 5-unit Storefront East Garrison Craftsman Elevation

Live/Work Rowhouses with Storefronts

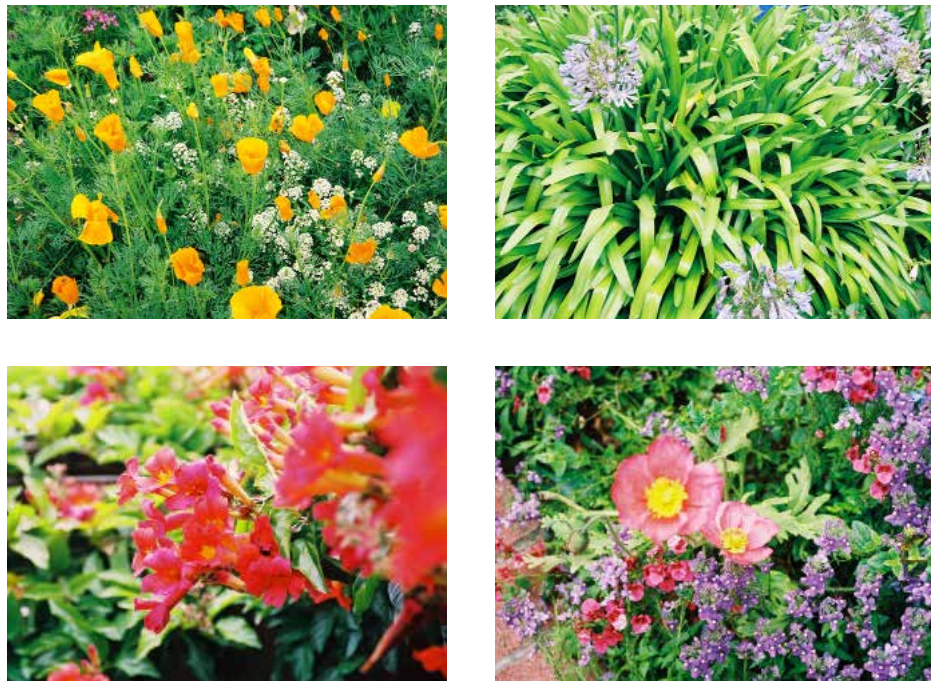

Examples of native plants

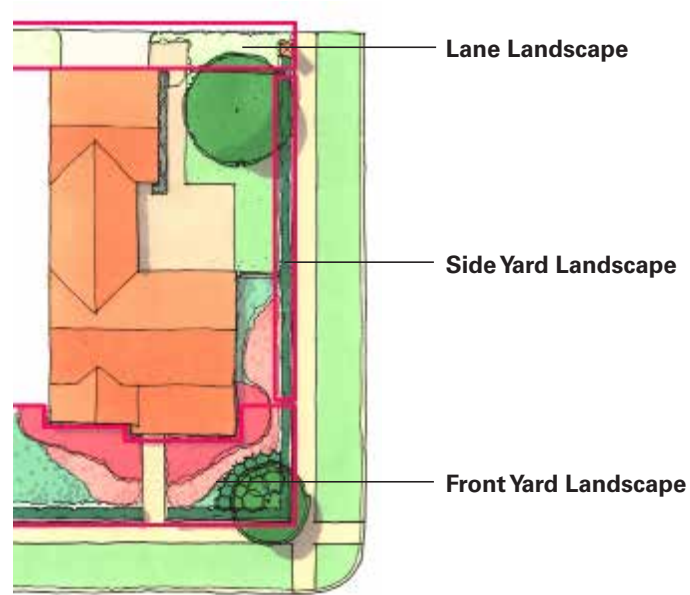

Priority planting areas

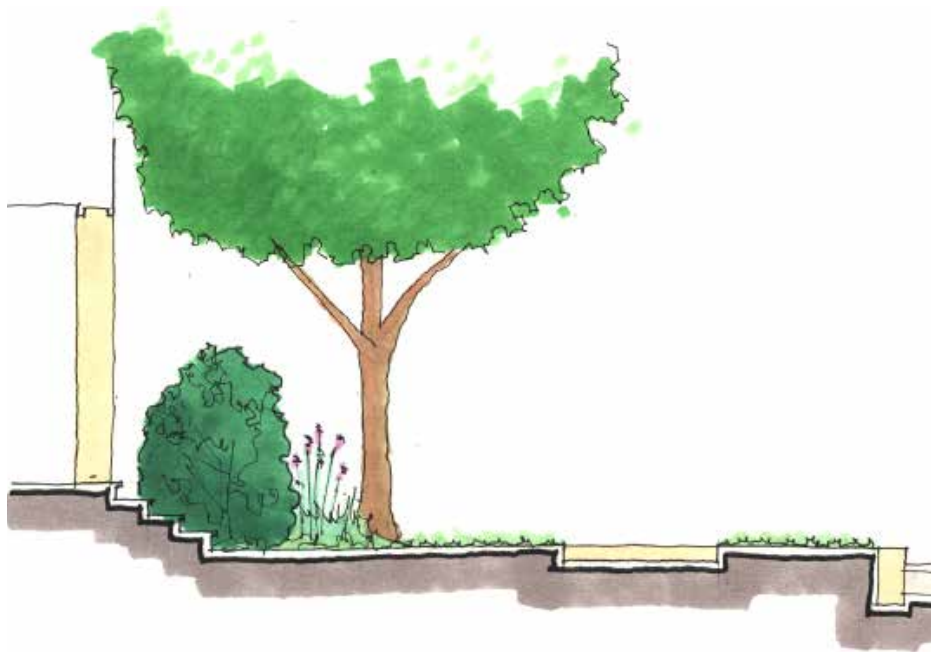

Illustrative section through front yard

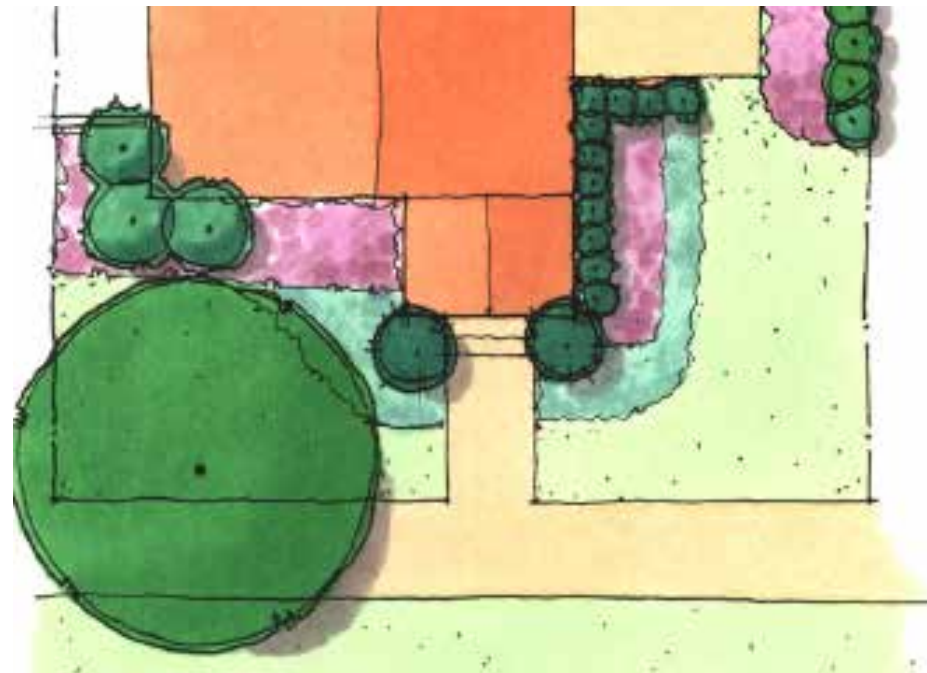

Illustrative landscape

Introduction

THE LANDSCAPE PATTERNS SECTION illustrates key elements and design strategies for private lots in three distinct landscape themes that are prevalent in the region. Mediterranean landscapes reflect the coastal influence of the region’s exotic and arid landscape. Cottage landscapes provide a diverse mixture of flower plantings for color and texture. The Arts & Crafts landscape represents a more formal image of the classic border garden. Regardless of landscape style, limited water availability drove a focus on using native plant materials of the region that require little or no irrigation.

Attractive landscapes in nearby communities contain a range of plant and hardscape materials. Hedges, fences, and walls often mark the front yard perimeter to create and beautify public street edges. Behind this edge is typically a mix of perennials, succulents, and native shrubs and ornamental trees. At East Garrison, the front yard landscapes will reflect this tradition.

This section begins with a description of front yard landscaping followed by the treatment of public street edges on private lots within a typical East Garrison block. Each landscape theme is then described in detail with standard planting requirements. Permitted upgrades are also included. Landscape principles for specific conditions, Courtyard Apartments and Garrison Apartment Homes, and Lanes, are also illustrated. The section ends with upgrade guidelines for landscape elements, including front yard fences and walls, rear yard fences and screens, private gardens, and palettes for irrigated and non-irrigated plant material.

The landscape patterns presented apply to front and side yards only, as indicated in the drawing (above left). Back yards, typically, are sold as dirt. Homeowners will be required to use the East Garrison Plant Palette when landscaping their back yards.

Landscape Patterns for Individual Lots

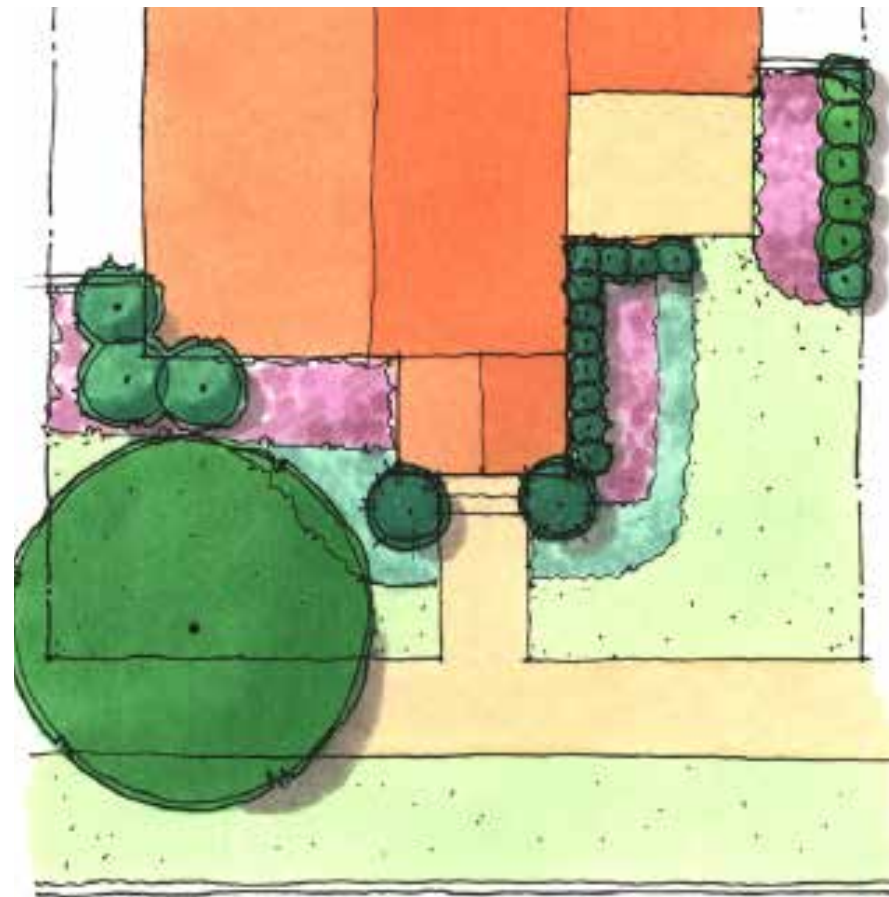

Standard Landscape Requirements (Qualities are listed on pages D4, D5, and D6)

- Concrete walks and patios
- Shade tree or ornamental tree
- Ornamental shrubs, groundcovers, and perennials
- Lawn
- Bark

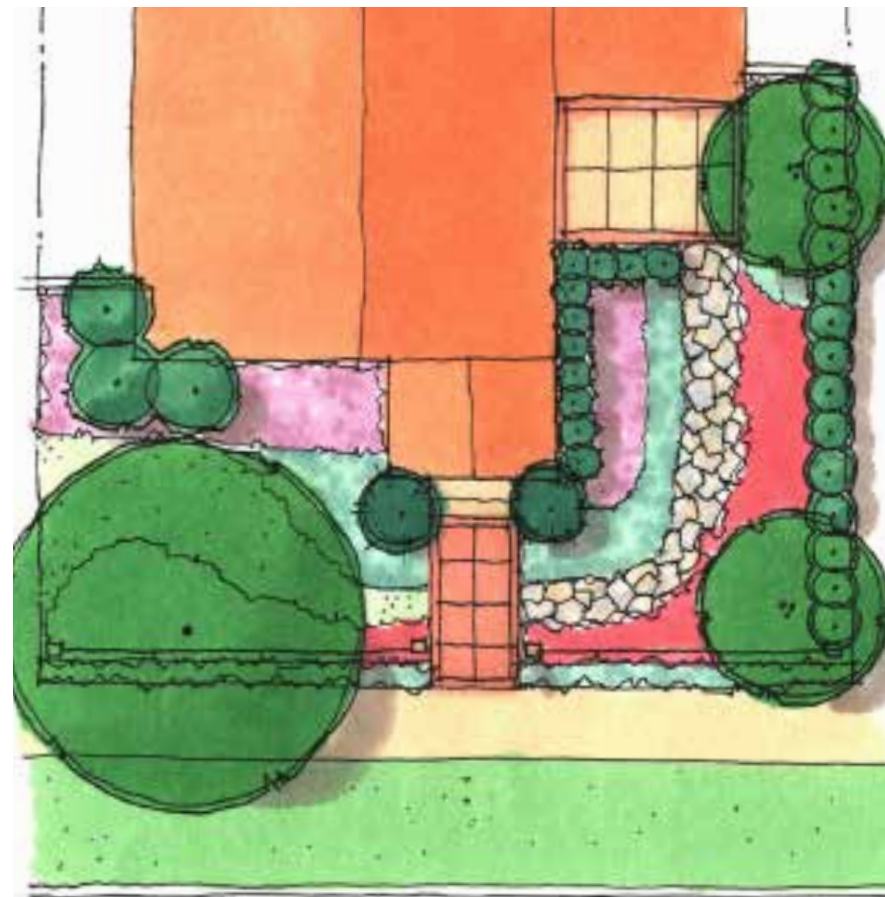

Permitted Landscape Upgrades

- Brick or stone entry walk
- Stone walkway or stepping stones to side garden
- Decorative brick edge and exposed aggregate concrete patio
- Standard garden planting plus extended garden area
- Property line articulation with walls, fences, or hedges
- Stepping stones

Note: Refer to individual landscape style pages for specific planting requirements.

Front Yard Landscapes

Each home in East Garrison will be required to meet a minimum standard for planting in the front yard, and, where applicable, for the side yard for corner lots thus extending the front yard landscape around the house.

The standard landscape plan for the front yard includes a tree (shade or ornamental), ornamental shrubs, groundcovers, and perennials. As mentioned earlier, there are three landscape types - Mediterranean, Cottage, and Arts & Crafts. Individual requirements for each garden are illustrated on the following pages. Each garden has a basic planting scheme with simple concrete walks bordered by lawn areas along the public sidewalks.

Permitted upgrades are intended to provide enhanced property line articulation to better define private landscapes from the public sidewalks as well as to expand the gardens with more plantings, thereby reducing the lawn areas. An expanded palette of materials is included, such as brick and stone pavers, wood fences, and walls. Ongoing enforcement of landscape requirements, after homeowners have taken over, will be the responsibility of the Community Services District (CSD) and/or the Homeowners Association (per the East Garrison Specific Plan, Section 5).



Typical mailbox, may be paired for a single family or ganged for townhouses

Front Yard Landscapes

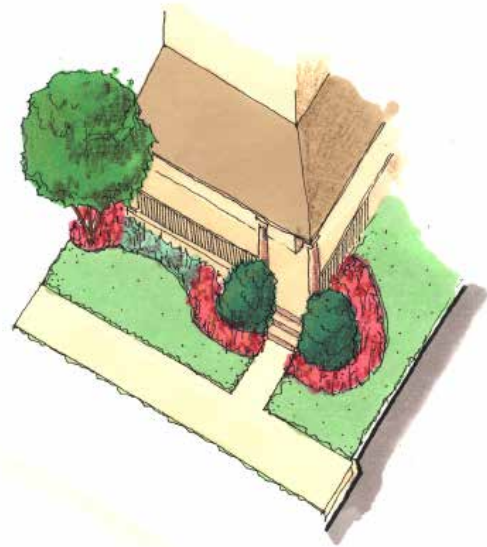

Standard Arts & Crafts landscape

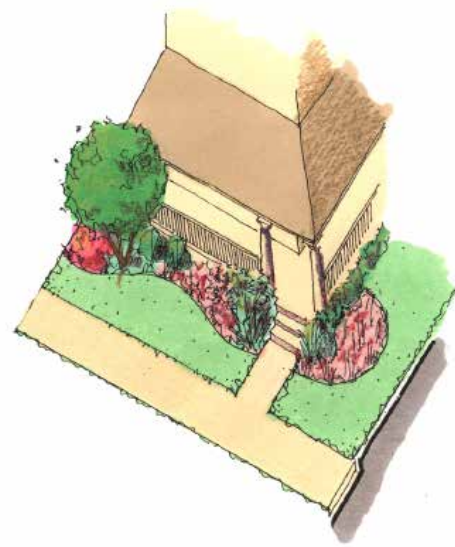

Standard Cottage landscape

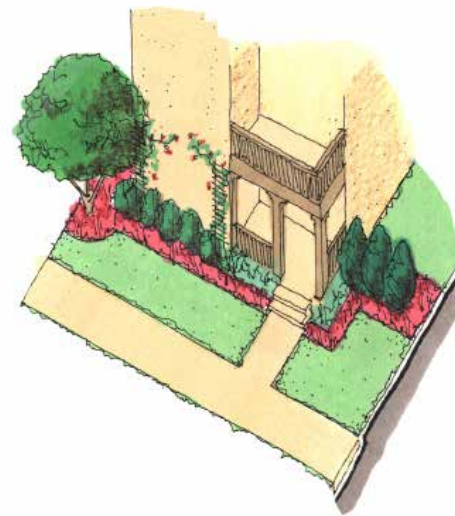

Standard Mediterranean landscape

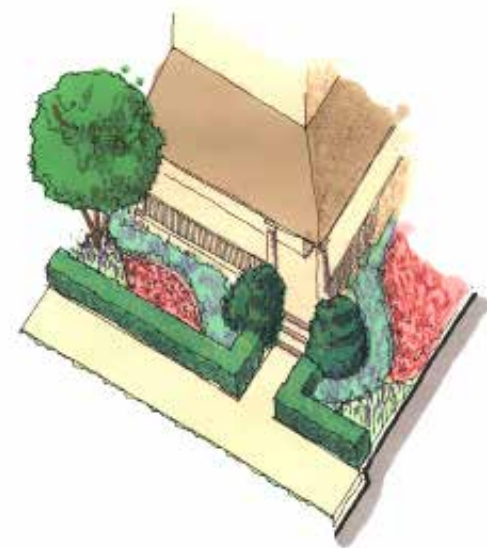

Permitted upgraded Arts & Crafts landscape

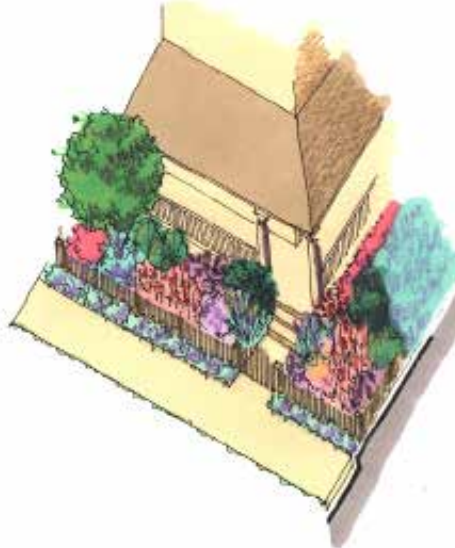

Permitted upgraded Cottage landscape

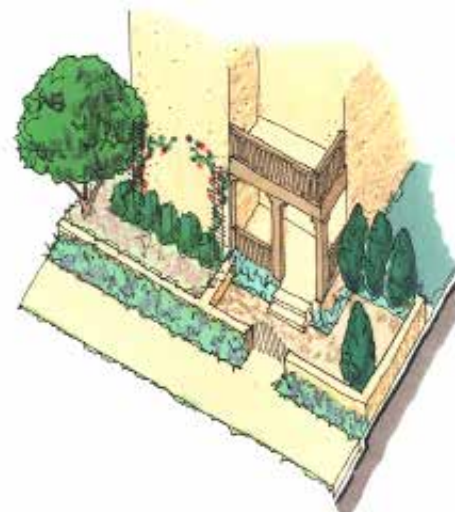

Permitted upgraded Mediterranean landscape

Landscape Styles

Three landscape styles have been developed for East Garrison in a standard version and with permitted upgrades. These landscape styles generally reflect the rich landscape traditions of the region.

The Mediterranean Landscape

The Mediterranean landscape will reflect the coastal climate with a mix of arid and exotic plantings in a courtyard setting. Vertical plantings, such as flowering trees, are typically set in the ground plane plantings of groundcovers, perennials, and succulents. These compositions can be symmetrical or informal in design emphasizing the entry to the house. Walls and gates can define a private entry courtyard which is a hallmark of this garden type. Courtyards open to the sky are typical in the private areas and are used as outdoor rooms and an extension of the house. This style of garden is recommended for Mediterranean Revival homes.

The Cottage Landscape

The Cottage landscape is the most prevalent in the region. Permitted upgrades, such as picket fences, arbors, and trellises can define entries and front yards. Plantings are primarily perennials with a scattering of ornamental shrubs and small flowering trees as accents. These landscapes are characterized by a mix of colors, layered with a variety of texture. This landscape style is most appropriate for the Picturesque Camp houses as well as selected Garrison Craftsman homes.

The Arts & Crafts Landscape

Another regional landscape type, the Arts & Crafts style is more formal and organized. As is typical of English border gardens, hedges formally define the edges of the garden and the more natural landscape patterns beyond the hedges. Ornamental shrubs and small trees are used as accents; plant palettes include groundcovers and perennials. Arts & Crafts gardens are best-suited for Garrison Revival and Garrison Craftsman houses.

Front Yard Landscape Styles

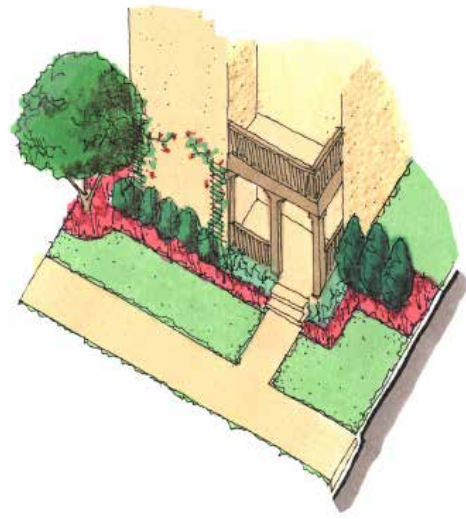

Standard Mediterranean landscape plan

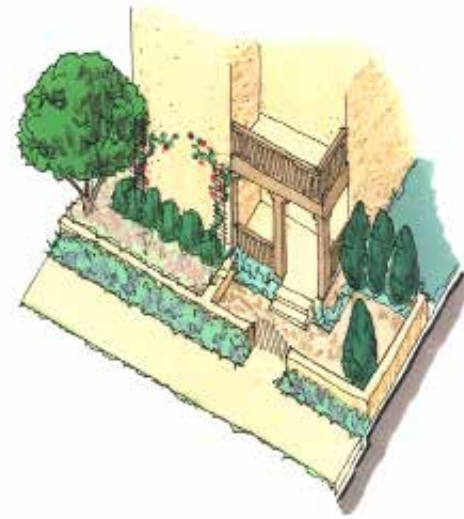

Permitted upgraded landscape with wall

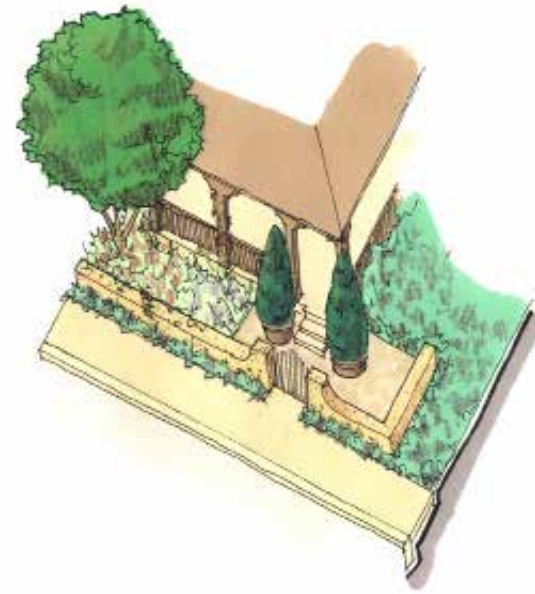

Permitted upgraded landscape with courtyard

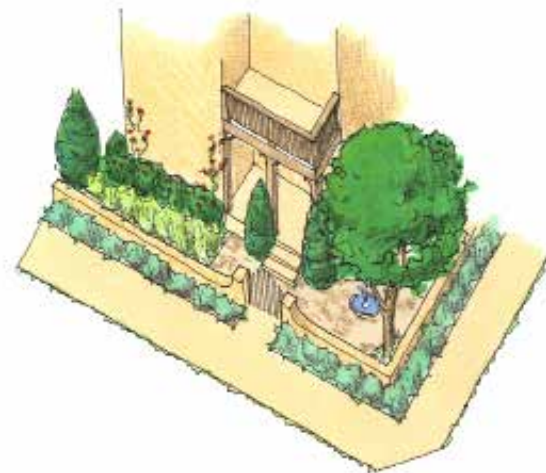

Permitted upgraded landscape at corner lot



Mediterranean Landscapes

Mediterranean landscapes are typical of the area and best represent the variety of the coastal landscape palette. These gardens usually have distinct courtyard garden entries. Courtyards open to the sky are typical in the private areas and are used as outdoor rooms and an extension of the house. Plant materials are wide-ranging, from succulents for texture to exotics for color, form, and accent. These gardens generally soften the architecture of the house with the use of flowering vines and textured plantings. The style can be formal or informal. Garden furnishings and materials are usually soft and more natural in character with plenty of color and texture.

Standard Landscape Requirements

- One shade tree or one ornamental tree per front and side street yards.
- Ornamental shrubs shall be provided for 35% of the area.
- Groundcovers shall be planted for a maximum of 20% of the area.
- A mixed palette of succulents and perennials shall be provided for 15% of the area.
- The balance of the front yard can be lawn from the planting beds to the edge of the public walkway. Per Monterey County regulations, 20% of the planted area, not to exceed 1,500 square feet per lot, is permitted to be irrigated.
- Front yard zones and side yard zones, where applicable, shall be irrigated.

Permitted Upgraded Landscape Options

- Property line articulation – Fences, walls, or hedges to define public edges and private gardens.
- An 18-inch planting strip may be provided between the sidewalk and wall, fences, or hedges. This area should be planted with groundcovers and perennials.
- Ornamental shrubs may be provided for 40% of the area.
- Groundcovers may be provided for a maximum of 30% of the area.
- The balance of the area may be a mixed palette of succulents and perennials.
- If courtyard entry paving is desired, maximum paved area shall be 25%; screen walls and gates are encouraged, maximum height shall be 48 inches.

Landscape Patterns – Mediterranean Landscapes

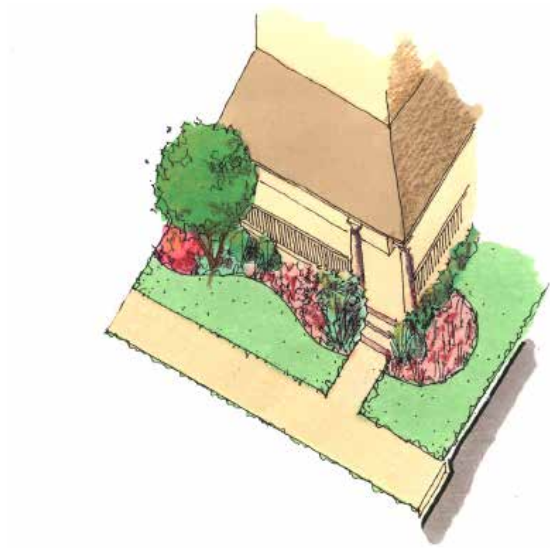

Standard Cottage landscape plan

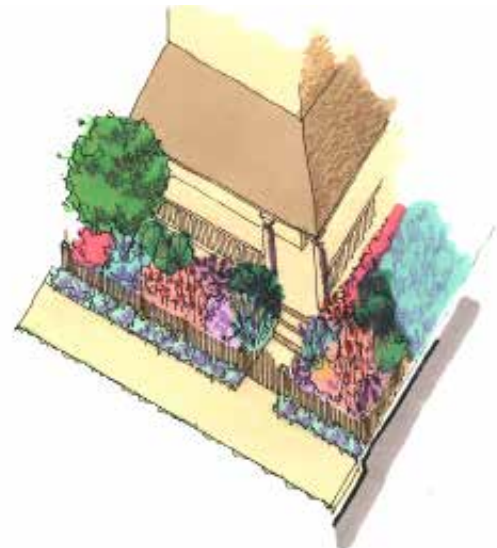

Permitted upgraded landscape with fence

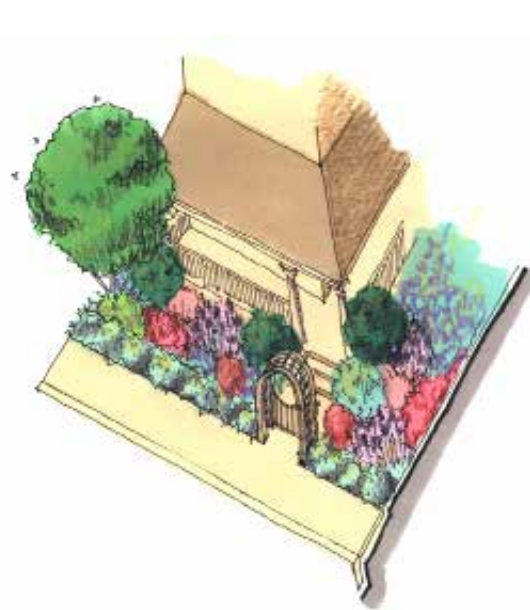

Permitted upgraded landscape with fence and arbor

Cottage Landscapes

Cottage gardens are the most prevalent landscape style found in the region. Sometimes defined as country gardens, these landscapes are the most diverse in style and planting palette. By definition, they are the essence of informality, ease, and individual expression.

Permitted upgrades include picket fences, arbors, and trellises and are informal in layout and plan. Plantings include a host of perennials and flowering shrubs.

These gardens are all about color and layers of texture and form. Just as the plantings are diverse, garden furnishings and materials can offer a wide variety from antique to country chic.

Standard Landscape Requirements

- One shade tree or one ornamental tree per front and side street yards.
- Ornamental shrubs shall be provided for 25% of the area.
- Groundcovers shall be provided for a maximum of 20% of the area.
- A mixed palette of succulents and perennials shall be provided for 15% of the area.
- The balance of the front yard can be lawn from the planting beds to the edge of the public walkway. Per Monterey County regulations, 20% of the planted area, not to exceed 1,500 square feet per lot, is permitted to be irrigated.
- Front yard zones and side yard zones, where applicable, shall be irrigated.

Permitted Upgraded Landscape Options

- Property Line Articulation – Fences, walls, or hedges to define public edges and private gardens.
- An 18-inch planting strip may be provided between the sidewalk and wall, fences, or hedges. This area should be planted with groundcovers and perennials.
- Ornamental shrubs may be provided for 25% of the area.
- Groundcovers may be provided for a maximum of 25% of the area.
- The balance of the area may be a mixed palette of succulents and perennials.
- Arbors, trellises, and entry gates are encouraged for homes with cottage landscapes.

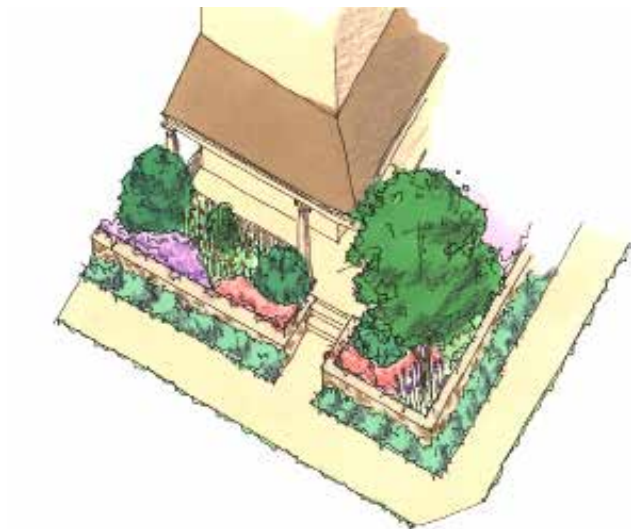

Permitted upgraded landscape at corner lot



Landscape Patterns – Cottage Landscapes

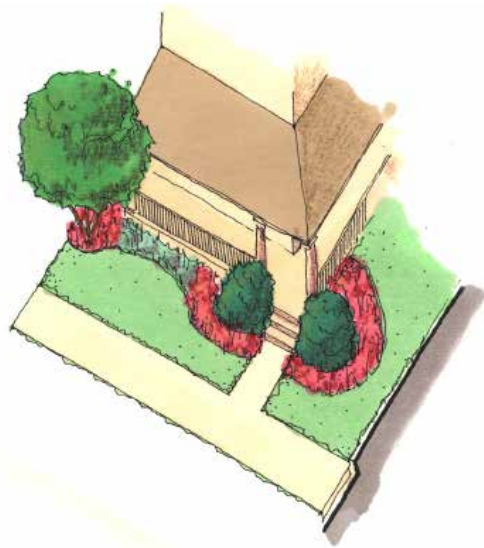

Standard Arts & Crafts landscape plan

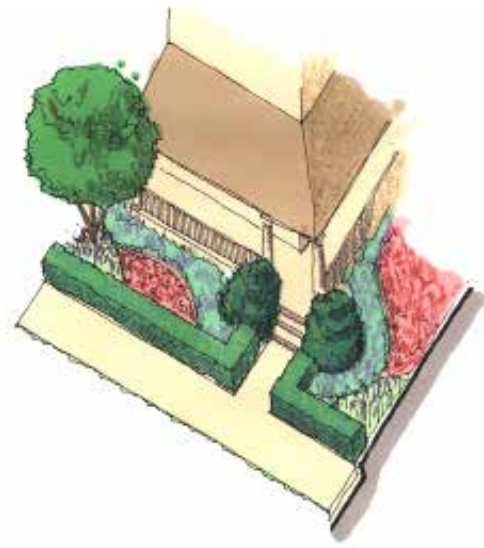

Permitted upgraded landscape with hedge

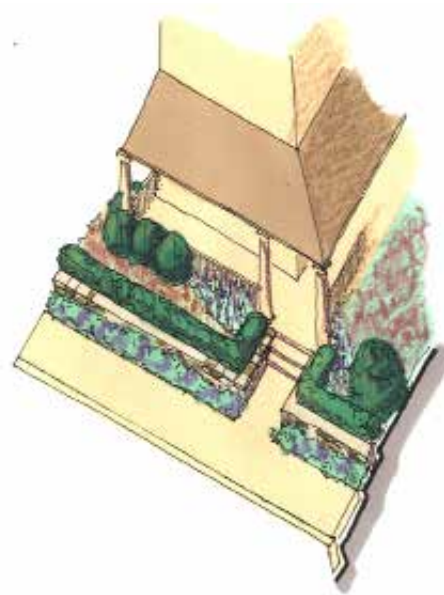

Permitted upgraded landscape with hedge and wall

Arts & Crafts Landscapes

Arts & Crafts gardens are historically more architectural in character and considered somewhat of a work of art that celebrates nature. These gardens have formal touches and are highly organized, but are tempered with a soft, natural landscape palette for variety and year-round beauty. Graceful and characterized by a careful and gradual transition from house to garden, often gardens of this type are created to be garden rooms defined by walls, trellis screens, hedges, or an allée of trees.

The formality of these gardens is usually greatest near the house, graduating to a more informal type of garden further out. Architectural elements are common, especially the use of pergolas or other features to extend the house into the garden. Rich paving materials, planters, planted courtyards, or formal lawns bordered by more informal plantings are common. In these gardens, a mix of ornamental plantings are balanced by a respect for native landscape materials.

Standard Landscape Requirements

- One shade tree or one ornamental tree per front and side street yards.
- Ornamental shrubs shall be provided for 25% of the area.
- Groundcovers shall be provided for a maximum of 25% of the area.
- A mixed palette of succulents and perennials shall be provided for 15% of the area.
- The balance of the front yard can

be lawn from the planting beds to the edge of the public walkway. Per Monterey County regulations, 20% of the planted area, not to exceed 1,500 square feet per lot, is permitted to be irrigated.

- Front yard zones and side yard zones, where applicable, shall be irrigated.

Permitted Upgraded Landscape Options

- Property Line Articulation – Walls or hedges to define public edges and private gardens.
- An 18-inch planting strip may be provided between the sidewalk and wall, fences, or hedges. This area should be planted with groundcovers and perennials.
- Hedge rows are permitted for this garden type along the property line or above the wall; plantings shall have a maximum hedge height of 42 inches.
- Ornamental shrubs to frame entryways and accent corners, not including the hedge row, shall be provided for a maximum of 25% of the area.
- Groundcovers shall be provided for a maximum of 25% of the area.
- The balance of the area shall be a mixed palette of succulents and perennials.

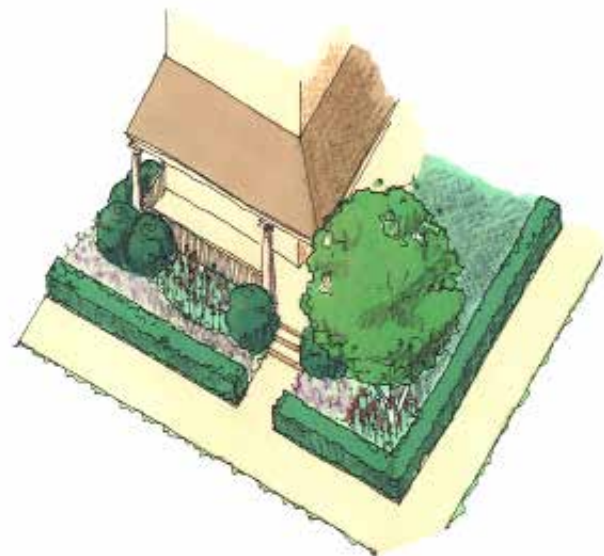

Permitted upgraded landscape at corner lot



Landscape Patterns – Arts & Crafts Landscapes



Courtyard Lots & Apartment Homes

The apartments of East Garrison will be styled in the image of California courtyard housing. The idea of a group of similar buildings centered on a common court or gathering space provides a unique social experience within the context of the broader community.

The interior courtyards will be areas where private entries, porches, patios, and balconies will have plantings to define semi-public and private spaces. These areas are best defined as gardens and will be a mixture of paved courtyards with landscaping. Garden elements such as fountains and planters are a permitted upgrade.

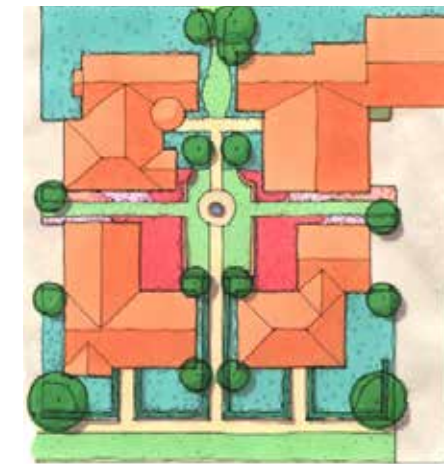

Illustrative shared zones in courtyard lots

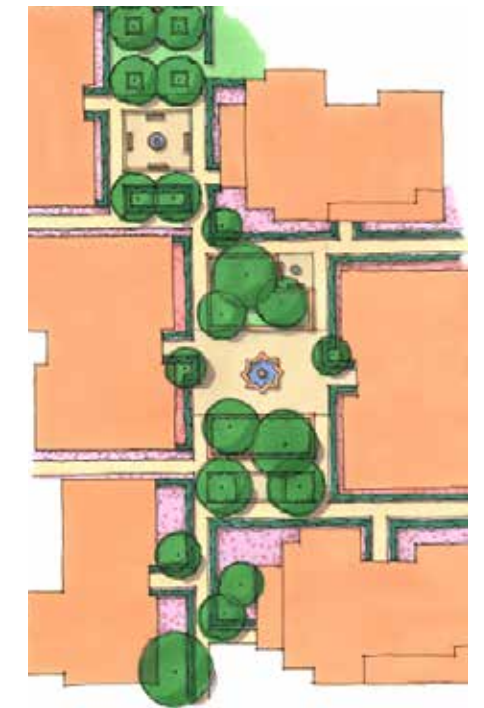

Illustrative shared zones in court apartment lots

Landscape Patterns – Shared Courtyard Elements

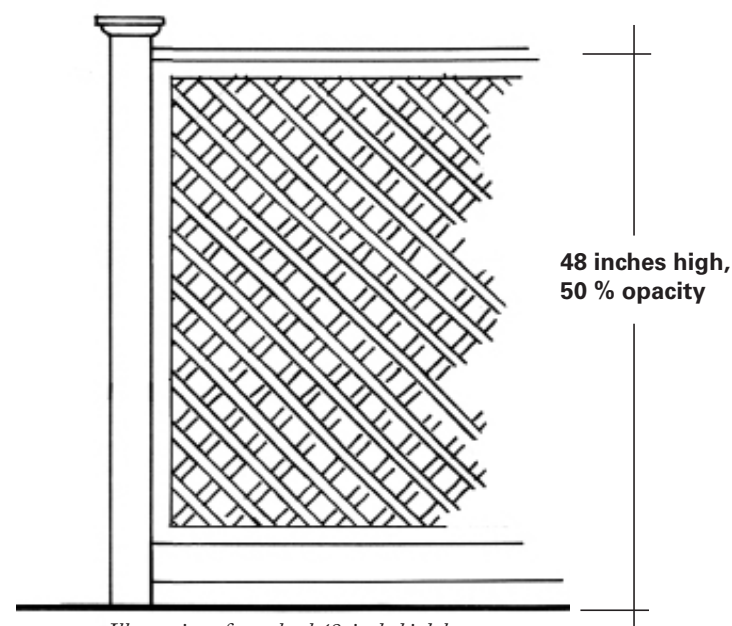
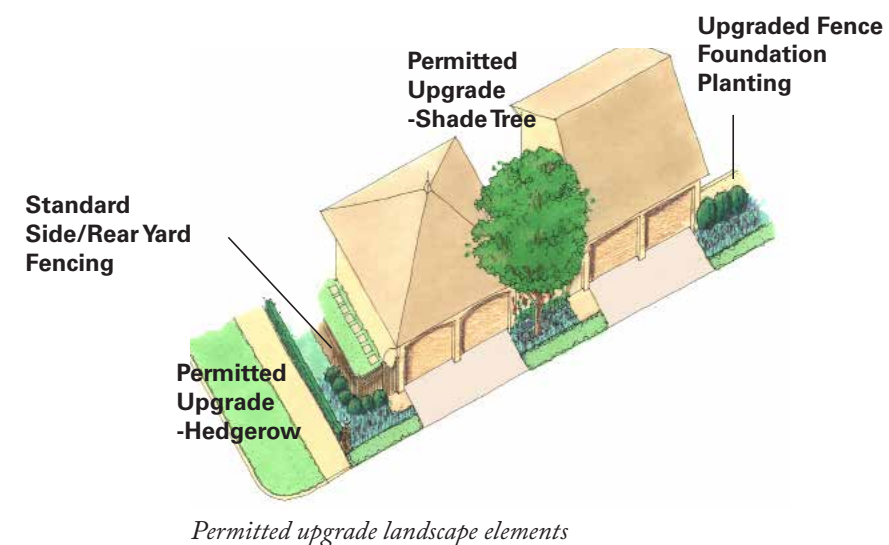
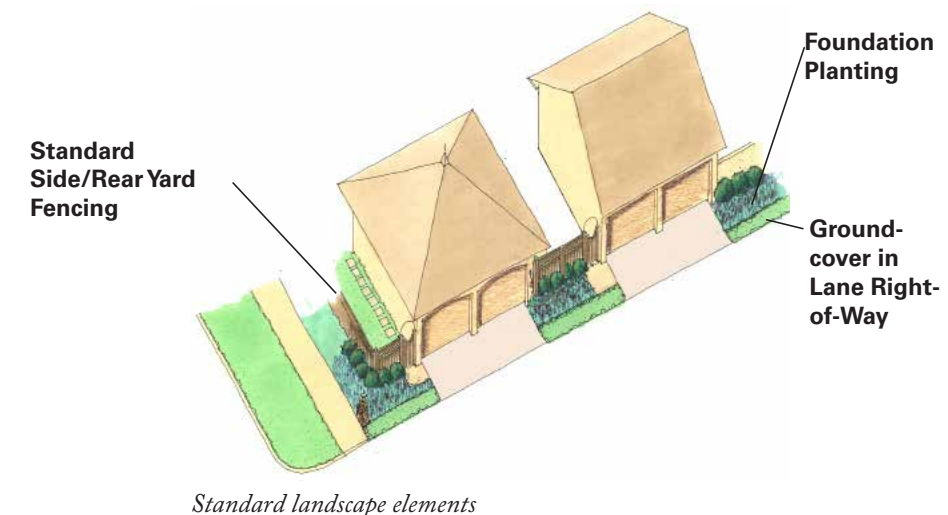

Illustration of standard 48-inch-high lane screen fence

Lane Elements

Lanes will define the rear property lines of each lot. The Rear Yard Setback Zone shall be landscaped with a palette of plantings to enhance the appearance of lanes. A 48-inch-high screen fence along the lane is required. This fence must have a minimum of 50% opacity. Drought-tolerant groundcovers, shrubs, and perenni-

als are required at the base of the fence. Trees are a permitted upgrade. To maintain the required 20-foot clear zone for emergency vehicles, the landscaping shall provide a 36-inch strip of low-spreading grasses or groundcovers such as Thyme or the Silvery or Greek varieties of Yarrow on each side of the lane.



Landscape Patterns – Lane Elements



Picket detail



Stucco wall with gate

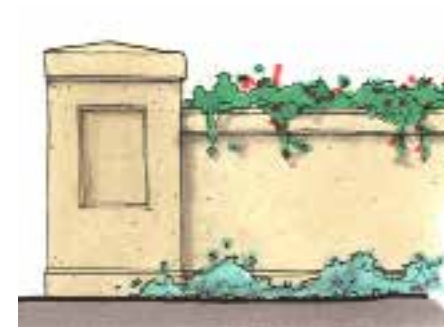

Illustrative stucco wall elevation



Illustrative stone wall elevation



Illustrative picket fence elevation

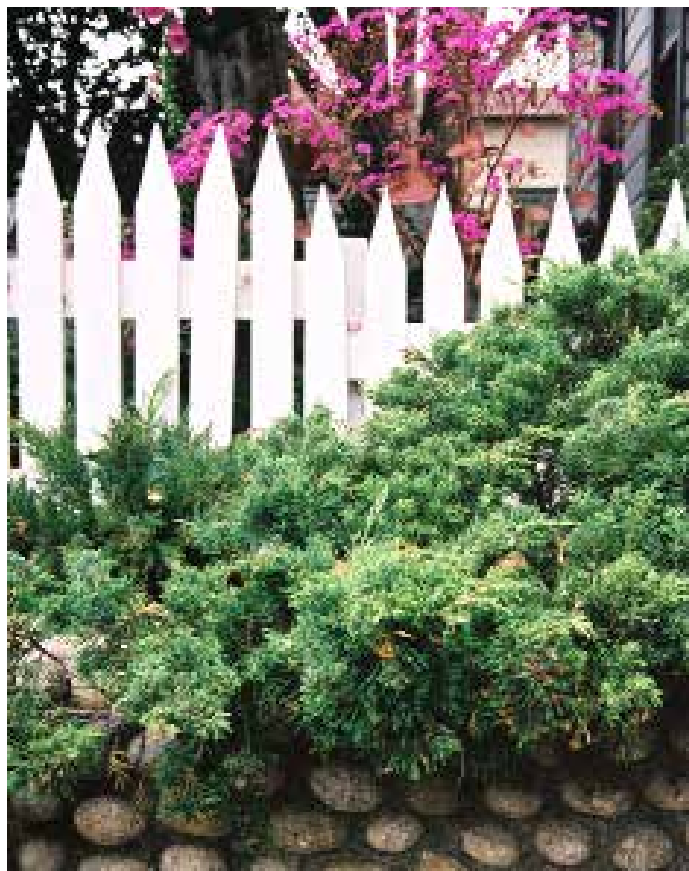

Picket fence with stone accent



Stucco wall with fence

Permitted Upgrades – Front Yard Fences & Walls

Front yard fences and walls are a permitted builder upgrade at East Garrison. When used, walls, fences, and hedges up to a maximum of 36 inches high will define the transition from the street to the yard. Fences and walls should be

consistent with the architectural style of the house. Materials shall be selected from the permitted materials list in the Architectural Patterns section of this Pattern Book.



Stone wall

Permitted Upgrades – Front Yard Fences & Walls



Solid rear yard fence



Rustic stucco screen fence



Rear yard entry off of alley



Rear yard screen fence



Typical rear yard fence

Rear/Side Yard Fences & Screens

Rear/side yard fences and screens are required for privacy at East Garrison. Materials shall be selected from the permitted materials list in the Architectural Patterns section of this Pattern Book. Walls and fences shall be four to six feet

in height. The appearance can be softened with vines and plantings. The top two feet of fences are required to have 50% opacity. Gates are permitted. Arbors are a permitted upgrade.

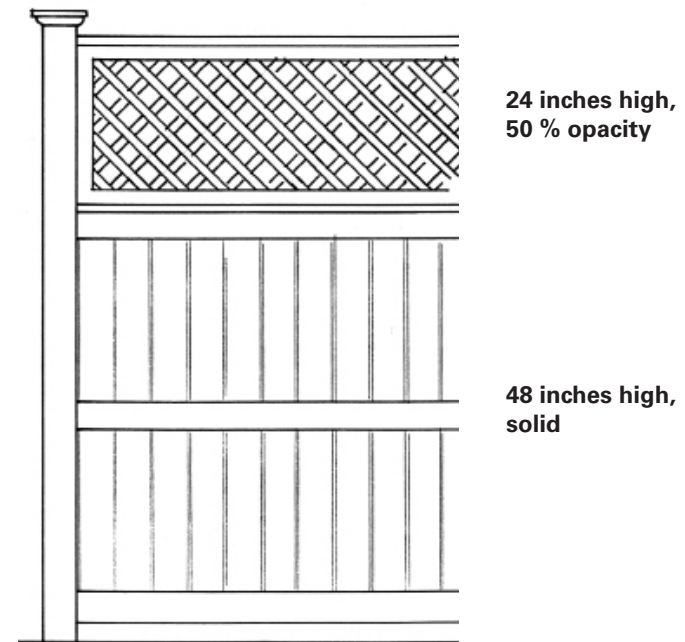
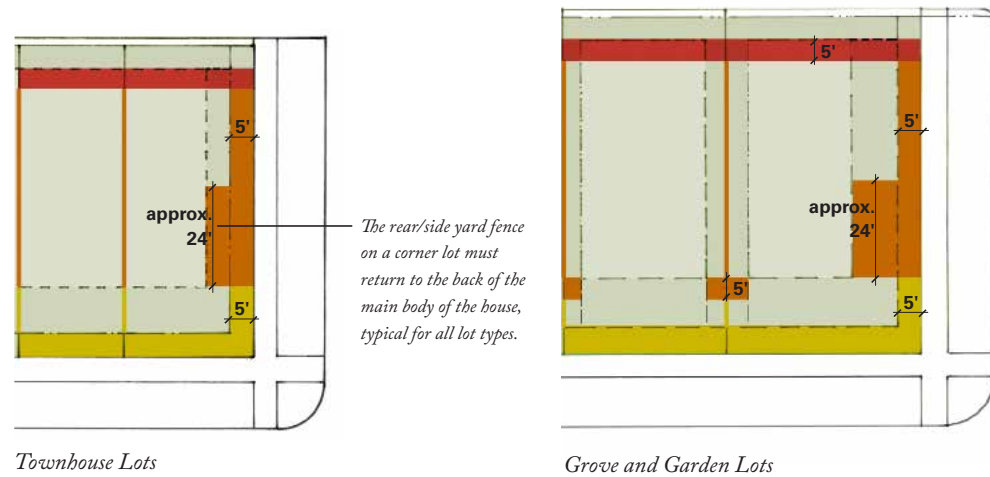

Illustration of standard 72-inch-high rear/side yard fence (not permitted in lanes)

Rear/Side Yard Fences & Screens



Key: Permitted Fence Locations

- Lane Fence Zone
- Rear/Side Yard Fence Zone
- Rear/Side Yard Fence Line
- Front Yard Fence Line
- Front Yard Fence Zone



Permitted Fence Locations

There are three different fence types in East Garrison: front yard, rear/side yard, and lane. Each plays an important role in the character of the streets and lanes, making fence locations critical.

The lot types in this plan have a set of zones and lines that describe where each fence type may be located. The zones have been made large enough to accommodate any landscaping or grading that

may be necessary and to ensure flexibility in the location of returns. In the case of rear/side yard fences at side streets, the zone has been increased in depth to allow the fence to return to the back of the main body of the house, wherever it may be sited.

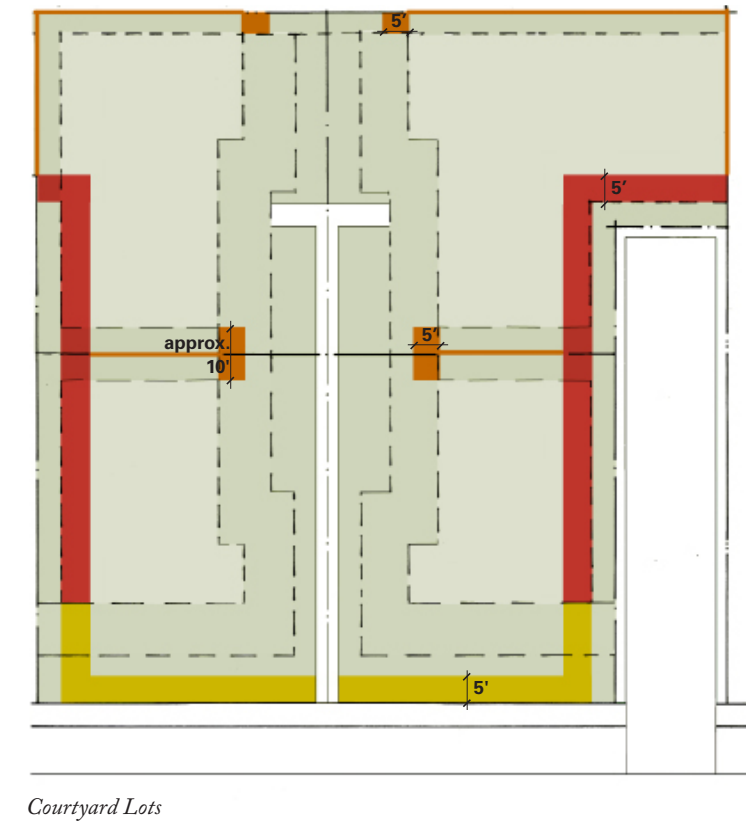
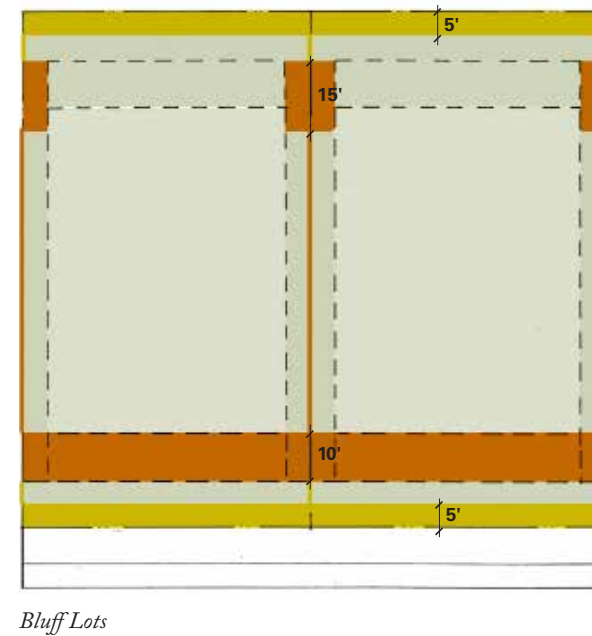
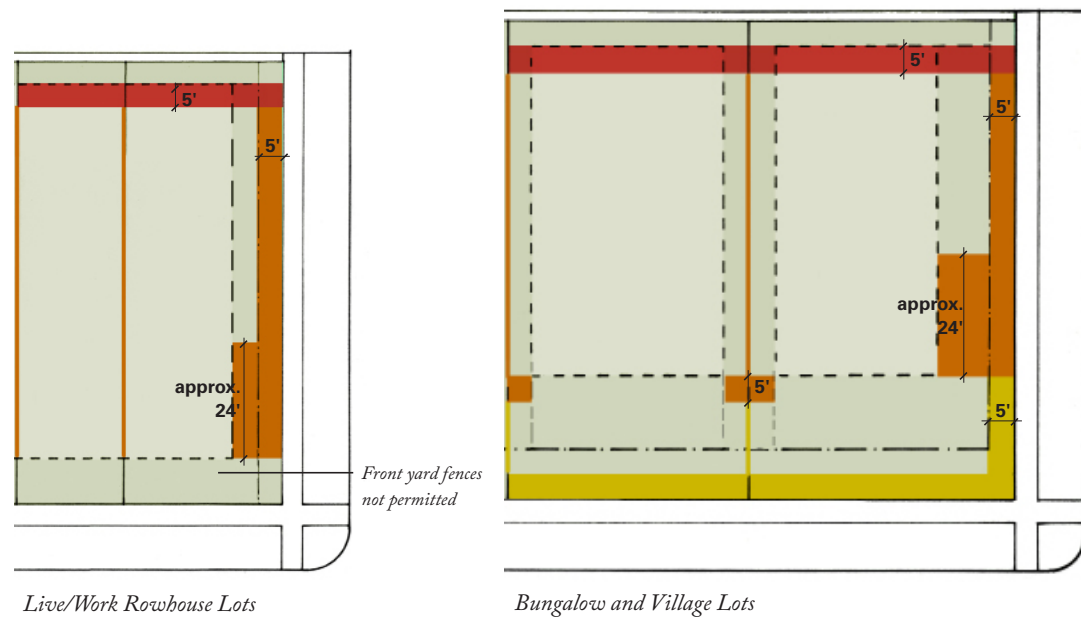

Permitted Fence Locations

Permitted Upgrades – Paving Surfaces

Concrete is the standard material for surface paving. Ornamental paving is a permitted upgrade. Entry landscapes may be enhanced by the use of materials including aggregate concrete, brick, or

stone. Homeowners can express their individual preferences in the private, interior gardens. Porous materials are recommended to enhance drainage.

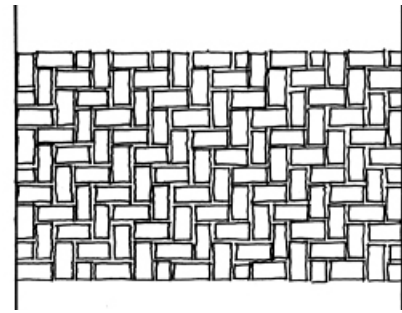

Typical brick paving pattern



Typical brick paving pattern

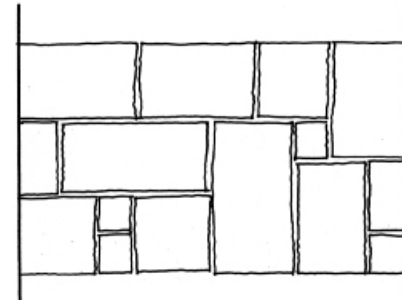

Gravel



Stone paving

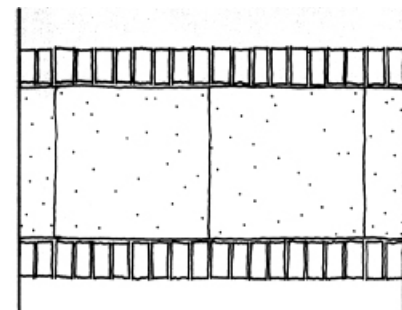

Exposed aggregate concrete paving



Porous concrete pavers with brick

Permitted Upgrades – Paving Surfaces

Plants Appropriate for A Non-Irrigated Native Landscape

Trees

Aesculus californica
Quercus agrifolia
Umbellularia californica

California Buckeye
Coastal Live Oak
California Bay Laurel

Grasses

Carex tumulicola
Festuca rubra cv.
Leymus condensatus cv.
Leymus condensatus cv.
Sidalcea malvaeflora
Nassella pulchra

Foothill Sedge
'Molate Blue'
'Canyon Prince'
'El Capitan'
Checkerbloom
Purple Needlegrass



Shrubs, Vines, and Herbaceous

Berberis aquifolium repens
Ceanothus cuneatus rigidus
Ceanothus cuneatus rigidus
Ceanothus incanus
Fremontodendron cv.
Garrya elliptica
Heteromeles arbutifolia
Mimulus aurantiacus cv.
Prunus illicifolia
Ribes malvaceum
Ribes speciosum
Rhamnus californica
Salvia clevelandii x leucophylla
Salvia clevelandii x leucophylla
Salvia clevelandii x leucophylla

Creeping Barberry
Monterey Ceanothus
'Snowball'
Coast Whitethorn
'California Glory'
Coast Silk Tassel
Toyon
'Jelly Bean Yellow'
Holly-Leaved Cherry
Chaparral Currant
Fuchsia Flowered Gooseberry
Coffeeberry
'Pozo Blue' Sage
'Allen Chickering'
'Whirly Blue'

Groundcover

Arctostaphylos edmundsii 'Carmel Sur'
Arctostaphylos pumila
Ceanothus gloriosus
Ceanothus gloriosus exaltatus
Ceanothus griseus horizontalis
Ceanothus griseus horizontalis 'Varigated'
Rhamnus californica cv.
Salvia mellifera 'terra seca'
Satureja douglasii

Carmel Sur Manzanita
Sandmat Manzanita
'Anchor Bay'
'Emily Brown'
Carmel Creeper
Variegated Carmel Creeper
'Eve Case' Coffee Berry
Creeping Black Sage
Yerba Buena

Annual Wildflowers

Eschscholzia californica
Lupinus nanus
Laylia platyglossa
Nemophila menziesii
Collinsia heterophylla

California Poppy
Sky Lupine
Tidy Tips
Baby Blue-Eyes
Chinese Houses



*Note: Approved equal(s) may be substituted for plants included in this list.

Landscape Palette – Non-Irrigated

Plants Appropriate for An Irrigated Landscape



Trees

Acer macrophyllum
Acer negundo californicum
Arbutus unedo
Juglans californica hindsii
Myrica californica
Quercus agrifolia

Big-Leaf Maple
 California Box Elder
 Strawberry Tree
 California Walnut
 Pacific Wax Myrtle
 Coastal Live Oak

Groundcover

Erigeron glaucus cv.
Ceanothus griseus horizontalis
Erigeron glaucus cv.
Stachys bullata
Zauschneria californica cv.

Sea Breeze
 'Carmel Creeper'
 'Wayne Roderick'
 Wood Mint
 'Everetts Choice'

Shrubs, Vines, and Herbaceous

Arctostaphylos x
Artemisia californica cv.
Carpenteria californica
Ceanothus
Ceanothus
Ceanothus
Ceanothus griseus
Ceanothus griseus
Ceanothus thyrsiflorus
Ceanothus thyrsiflorus
Garrya elliptica cv.
Rhamnus californica cv.
Rhamnus californica cv.
Rhus ovata
Ribes malvaceum cv.
Ribes malvaceum cv.
Ribes sanguineum glutinosum cv.
Ribes speciosum
Salvia mellifera prostrata
Vaccinium ovatum

'Sunset'
 'Montara'
 Tree Anemone
 'Joyce Coulter'
 'Julia Phelps'
 'Frosty Blue'
 'Ray Hartman'
 'Kurt Zadnick'
 'Louis Edmonds'
 'El Dorado'
 'Snow Flurry'
 'James Roof'
 'Eve Case' Coffee Berry
 'Mound San Bruno'
 Sugar Bush
 'Dancing Tassels'
 'Rana White'
 'Claremont'
 Fuchsia Flowered Gooseberry
 'Terra Seca'
 Evergreen Huckleberry

Succulents

Arctostaphylos x
Arctostaphylos edmundsii cv.
Dudleya caespitosa
Dudleya cymosa
Dudleya farinosa
Dudleya hassei
Dudleya lanceolata
Sedum obtusatum
Sedum spathulifolium

'Emerald Carpet'
 'Carmel Sur'
 Sea Lettuce
 Spreading Dudleya
 Bluff Lettuce
 Hass's Live-Forever
 Lance Leaved Live-Forever
 Sierra Stonecrop
 Stonecrop

Perennials

*Heuchera x**
*Heuchera x**
*Heuchera x**
Iris douglasiana
Mimulus aurantiacus cv.
Mimulus aurantiacus cv.
Mimulus hybrids
Penstemon heterophyllus x
*Romneya coulterii **

'Chiqui'
 'Canyon Pink'
 'Wendy'
 Douglas Iris
 'Jelly Bean White'
 'Jelly Bean Yellow'
 Persoff Hybrids
 'Margarita BOP'
 Matilija Poppy



*Notes: Approved equal(s) may be substituted for plants included in this list.

Plants listed as moderate or high water users by the California State Water Resources Department and therefore must be limited (in any combination) to 5% of the total planted area.

Landscape Palette – Irrigated



Front facade of the Chapel



Battle Simulation Building



Theater elevation facing Sloat Street

THIS SECTION OF THE PATTERN BOOK contains design guidelines for the rehabilitation of the wood buildings on site. There is one wood building, the Chapel, that will be retained in the Historic District. The Theater and the Battle Simulation Building will also be retained if economically feasible. The existing addition on the Battle Simulation Building is likely an early addition (possibly during the historic period) and could be either restored or removed. Although not contributors to the district, these buildings will be rehabilitated based on guidelines similar to those for the historic concrete buildings. All feature two-story-high interior spaces with a mezzanine level. The buildings rest on poured-concrete foundations. The roofs are supported by wood trusses, purlins, and rafters.

The doors were likely paneled, but many have been replaced with hollow-core (metal and wood) and several openings are boarded up. The windows are typically double-hung with wood frames, sashes, and sills. Light patterns vary based on the size of the window. Currently, many windows are simply covered by wire mesh.

Character Defining Elements

EXTERIOR

- Wood frame construction covered with wood sheathing (the Battle Simulation Building is clad with composite shingles)
- Moderately-pitched gabled roofs
- Composite shingle roof
- Regular fenestration patterns
- Wood double-hung windows
- Wood panel doors

INTERIOR

- Open ceilings with exposed truss and duct work
- Concrete floors (the chapel has a wood floor)

SETTING

- Green space and pavement around the buildings

Overview

Wood

A number of wood buildings were constructed at the East Garrison during World War II, including the Theater, Chapel, and Battle Simulation Building.

Moisture, usually in combination with other influences, such as insects and fungi, weakens the structure of wood and is the main cause of wood deterioration. Paint is one of the most effective means of waterproofing a wood surface; and most exterior wood at the East Garrison has been painted. Treatments for insect and fungal attack include treating wood with insecticides and preservatives, treating the surrounding soil, and fumigating. However, each of these methods is also harmful to the environment and can damage certain types of metal, paint, and interior finishes.



Chapel rear elevation

Identify, Retain, & Preserve

RECOMMENDED

- Identify, retain, and preserve wood features that are important in defining the overall traditional character of the building, such as siding, cornices, brackets, window architraves, and doorway pediments, and their paints, finishes, and colors.
- Identify species of wood, grain pattern, dimensions, and means of fastening.
- Determine if a wood element functions as a structural, decorative, or finish material and select the appropriate treatment.

NOT RECOMMENDED

- Removing or radically changing wood features that are important in defining the overall traditional character of the building, such that the character is diminished.
- Removing a major portion of the historic wood from an elevation (instead of repairing or replacing only the deteriorated wood), then reconstructing the elevation with new material to achieve a uniform or “improved” appearance.
- Radically changing the type of finish or its color or accent scheme so that the historic character of the exterior is diminished.
- Stripping historically painted surfaces to bare wood, then applying clear finishes or stains to create a “natural look.”

Wood

Protect & Maintain

RECOMMENDED

- Protect and maintain wood features by providing proper drainage so that water is not allowed to stand on flat, horizontal surfaces.
- Retain coatings, such as paint, that help protect the wood from moisture and ultraviolet light. Paint removal should be considered only where there is paint deterioration and as part of an overall maintenance program that involves repainting or applying other appropriate protective coatings.
- Remove deteriorated paint to the next sound layer using the gentlest method possible (hand scraping and hand sanding), and then repaint.
- Carefully use electric heat plates on flat wood surfaces when paint is so deteriorated that it must be totally removed prior to repainting.
- Use chemical strippers primarily to supplement other methods, such as hand scraping, hand sanding, and the above-recommended thermal devices. With the proper safeguards, detachable wooden elements, such as doors and windows, can be chemically dip-stripped.
- Limit paint removal. Generally, wood should be stripped only if it is necessary to make elements operable (such as windows), or to remove lead-containing paint.
- Correct conditions that allow moisture intrusion.
- Provide adequate ventilation.
- Evaluate the overall condition of the wood features to determine if protection and maintenance are sufficient, or if repair is necessary.
- Apply compatible paint-coating systems following proper surface preparation.
- Repaint with the historic color.
- Inspect wood surfaces and structural elements regularly for signs of moisture retention and insect or fungal attack. Peeling paint, spongy wood, discoloration, staining, and the presence of fungi are clear indicators. Insect damage often occurs on the interior of a wood member and may be hidden until the structural integrity is compromised. Wood joints or connections with concrete are particularly susceptible to rot because they are frequently subject to moisture.

NOT RECOMMENDED

- Failing to identify, evaluate, and treat the causes of wood deterioration, including faulty flashing, missing roof shingles, deteriorated caulking in joints and seams, plant material growing too close to wood surfaces, or insect or fungal infestation.
- Using chemical preservatives, such as creosote, that can change the appearance of wood features.
- Removing paint or other coatings to reveal bare wood, thus exposing historically coated surfaces to the effects of accelerated weathering.
- Removing paint that is firmly adhering to, and thus protecting, wood surfaces.
- Using destructive paint-removal methods, such as propane or butane torches, sandblasting, or water blasting. These methods can irreversibly damage woodwork.
- Failing to thoroughly neutralize the wood after using chemicals; unless the wood is neutralized, new paint will not adhere.
- Allowing detachable wood features to soak too long in a caustic solution, which raises the wood grain and roughens the surface.
- Failing to follow manufacturer's product and application instructions when repainting exterior woodwork.
- Using new colors that are inappropriate to the traditional building or district.
- Failing to undertake adequate measures to ensure the protection of wood features.
- Relying on brush- or spray-applied insecticides or preservatives, or those incorporated into paint coatings. These are generally ineffective, because penetration is superficial and the interior of the member is unprotected.
- Treating wood with preservatives that alter its appearance. Preservatives can stain or corrode adjacent materials, and may affect future paint application.
- Applying sealants without addressing the cause of the problem or as a substitute for good detailing of joints and flashing.

Wood

Protect & Maintain (cont'd)

RECOMMENDED

- Maintain successful existing details of joints and flashing that keep water out of wood assemblies, and consider traditional detail reconstruction before caulking.
- To reduce paint buildup on the exterior and interior, paint only those elements that require repainting. However, spot painting is generally not recommended, because it creates an irregular appearance.

NOT RECOMMENDED

Repair

RECOMMENDED

- Repair wood features by patching, piecing-in (Dutchman), consolidating, or otherwise reinforcing the wood using recognized preservation methods. Where there are prototypes, repair may also include the limited replacement in kind or with compatible substitute material, of extensively deteriorated or missing parts of features.
- Strengthen weakened wood members by adding new members alongside the original. Wood structures are most commonly weakened when the original cross section of a structural member is reduced by cutting out portions during alterations, by fire, or by insect damage or fungal rot. Rot on the original member must be treated or removed before installing new material.
- Replace missing wood features, especially those on the exterior, in a timely manner. Exterior wood components are usually designed and joined to prevent water from penetrating joints. One missing element can compromise the entire system.
- Remove damaged or decayed sections only, rather than the entire wood member. Repair wood elements using wood that matches the original in dimension, finish, and species, unless the species is endangered, in which case an appropriate substitute should be used.
- Repair voids left after removal of damaged wood by inlaying pieces of wood cut to precisely fit the void. In this type of repair, called a Dutchman, the wood should match the original in species and color, and care should be taken to continue the grain pattern.
- Cut vertical replacement pieces on a diagonal to direct water from the joint. Horizontal joints tend to collect water.
- Consolidate deteriorated wood rather than replacing the original, where possible. In some nonstructural locations, such as wood sills, injection of a polymer composite material (e.g., a flexible epoxy restoration compound that can be carved) is an appropriate means to extend the life of a wood component.
- Use pre-drilling and screws in old brittle wood rather than nails to minimize cracking and splitting.

NOT RECOMMENDED

- Replacing an entire wood feature, when repair of the wood and limited replacement of deteriorated or missing parts are appropriate.
- Using substitute material for the replacement part that does not have the appearance of the surviving parts of the wood feature or that is physically or chemically incompatible.
- Using nongalvanized fasteners in moist conditions. These can discolor and chemically attack certain woods, including redwood, Douglas fir, and oak.
- Nailing old brittle wood, causing it to split.

Replace

RECOMMENDED

- Use the physical evidence as a model and replace in kind an entire wood feature that is too deteriorated to repair.
- Where repair and restoration are not possible, match the original wood as exactly as possible in wood species (if not endangered), grain, dimensions, finish texture, and coating. Current dimensions of lumber are often different from historic dimensions, and custom milled lumber will probably be necessary.
- Replace wood features using the same joining techniques as found in the original feature.
- Replace exterior composite shingles (Battle Simulation Building) with cement siding shingles of similar dimension and appearance.

NOT RECOMMENDED

- Removing an entire wood feature that is beyond repair and not replacing it, or replacing it with a new feature that does not have the same appearance.
- Replacing milled lumber with plywood. Plywood is both historically inappropriate and visually distinct from traditional wood.

Design for Missing Traditional Features

RECOMMENDED

- Design and install a new wood feature, such as a doorway, when the original feature is completely missing. Accurate restoration may be based on historic photographs or plans, or physical documentation of identical features on the building or another building of the same exact type.

NOT RECOMMENDED

- Creating a false traditional appearance because the replaced wood feature is based on insufficient pictorial or physical documentation.
- Introducing a new wood feature that is incompatible in size, scale, material, or color.
- Introducing inappropriate materials that mimic traditional materials, such as aluminum siding. These are unacceptable because they substantially alter a building's visual characteristics.

Windows

With minor variations, there are only a few window types used in the wood buildings at the East Garrison. Wood double-hung windows are the primary type, with a variety of light configurations. The windows and frames are simple. The fenestration is generally regular and symmetrical. Daylight is an important feature of most interiors.

As one of the few parts of a building serving as both an interior and an exterior feature, windows are always an important part of the traditional character of a building. In the Chapel and the Battle Simulation Building, windows form a considerable amount of the traditional fabric of the wall plane, and thus are deserving of special consideration in a rehabilitation project.

Some window sash replacement has occurred at the East Garrison, primarily evident in the change from multi-light, small-paned windows to single-paned sashes. Many of the windows are covered with chain link fencing and plywood panels (some with vents). These were installed to protect the windows and can be easily removed.

The primary cause of window deterioration is rain driving against and into windows, and standing water on sills. At the East Garrison, this condition is exacerbated by extended periods of damp weather, which prevent windows from drying out and encourage expansion and rot.

In some cases, the installation of insulating or low-E glazing or glass-applied film may be an appropriate energy-saving device. Well-maintained, operable windows will be an important and preferred component in creating an efficient ventilating system for most buildings. Replacement windows and components, when required, should be replaced in kind and constructed of materials of the highest quality.

Identify, Retain, & Preserve

RECOMMENDED

- Identify, retain, and preserve windows – and their functional and decorative features – that are important in defining the overall traditional character of the building.
- Conduct a survey of the conditions of windows early in rehabilitation planning so that repair and upgrade methods and possible replacement options can be fully explored.
- Consider a window's place as a component of the principal exterior facade and its contribution to an interior space when determining its significance.
- Preserve all remaining original glazing. Historic glass often has distortions and imperfections not found in modern glass.

NOT RECOMMENDED

- Removing or radically changing windows that are important in defining the traditional character of the building.
- Changing the number, location, size, or glazing pattern of windows, through cutting new openings, blocking in windows, enlarging openings, or installing a replacement sash that does not fit the existing window opening.
- Changing the traditional appearance of windows through the use of inappropriate designs, materials, finishes, or colors that noticeably change the sash, depth of reveal, muntin configuration, reflectiveness or glazing color, or the appearance of the frame.
- Obscuring traditional window trim with metal or other material, or stripping windows of original materials, such as wood.
- Replacing windows solely because of peeling paint, broken glass, stuck sash, or air infiltration. These conditions, in themselves, are not indications that windows are beyond repair.

Windows

Protect & Maintain



RECOMMENDED

- Protect wood window frames, sash, muntins, and surrounds, through appropriate surface treatments like cleaning, limited paint removal, and reapplication of protective coating systems.
- Make windows weather tight and thermally efficient by recaulking and installing weather stripping.
- Evaluate the overall condition of materials to determine whether repairs to windows or window features are needed.
- Keep glazing clear to maximize the natural light.
- Preserve operating systems for historic windows (e.g., weights on double-hung windows), repairing or replacing components as needed.
- Consider using storm windows, installed on the interior, when their impact on interior features would be minimal and reversible.

NOT RECOMMENDED

- Failing to provide adequate protection of materials on a cyclical basis, such that deterioration of the windows results.
- Retrofitting or replacing windows rather than maintaining the sash, frame, sill, muntins, and glazing.
- Failing to undertake adequate measures to ensure the protection of existing windows.
- Painting over windows to limit the entry of daylight for new building use.

Windows

Repair

RECOMMENDED

- Repair window frames and sash by patching, splicing, consolidating, or otherwise reinforcing. Repair may also include replacement in-kind of parts that are extensively deteriorated or missing, when there are surviving prototypes.
- Repair defective sills to permit drainage. Window deterioration usually begins on horizontal surfaces and at joints where water collects, saturating wood.
- Repairing of original windows is always preferred to replacement. Usually the sill must be replaced first, then the lower sash parts. Splicing or Dutchman repair can be an effective method of repairs.
- If replacement is required, limit it to severely deteriorated components.
- Clean and oil hardware that was painted over; in most cases, repair, rather than replacement, should be possible.
- Remove built-up paint that causes sashes to be inoperable.
- Remove earlier repairs that are insensitive to the historic features and materials, and repair according to accepted standards.

NOT RECOMMENDED

- Replacing an entire window when repair of materials and limited replacement of deteriorated parts are appropriate.
- Failing to reuse serviceable window hardware, such as sash lifts and sash locks.
- Using substitute material for the replacement part that does not have the appearance of the surviving parts of the window or that is physically or chemically incompatible.

Replace

RECOMMENDED

- Replace in-kind an entire window that is too deteriorated to repair, using the same sash and pane configuration, other design details, and original material.
- Always keep replacement to a minimum. Where sash replacement is required, attempt to retain the window frame, hardware, and trim.
- Replacement may be the only feasible option when substantial structural damage to a window has occurred. Choose a replacement window with particular care. Ideally the new window should be an exact match of the old one. If this is not possible, carefully consider all of the window's characteristics, both interior and exterior, and its importance in the facade, and select a replacement that matches the original as closely as possible.

NOT RECOMMENDED

- Removing a window that is beyond repair and blocking it in.
- Replacing an existing window with a new window that does not have the same appearance.
- Replacing existing windows simply to enhance the energy conservation performance of a building.

Design for Missing Traditional Features

RECOMMENDED

- Design and install new windows when the original windows (frames, sashes, and glazing) are completely missing. The replacement windows may be an accurate restoration using pictorial and physical documentation.
- Restore windows that were blocked in or boarded up after World War II, where possible, and where adequate documentation exists. Other buildings of the same type may be used as models.

NOT RECOMMENDED

- Creating a false traditional appearance because the replaced window is based on insufficient pictorial or physical documentation.

Windows

Alterations & Additions for New Use

RECOMMENDED

- Design and install additional windows on elevations that are not highly visible.
- Consider the effect of any interior changes on existing windows and trim, and the appearance of these changes from outside the building (as seen through the windows).
- Weatherization and maintenance of windows, and the installation of curtains or interior shutters, will alleviate some noise, but in some situations, additional measures, such as new glazing, may be necessary. Laminated glazing is preferable to double or triple glazing.
- Design modification details so that they have a minimal visual impact on the traditional appearance of a building.
- Address energy conservation by changing to insulated glazing when new windows are required, adding exterior or interior shading devices or storm windows, or, when appropriate, applying solar control film to window glass. Interior blinds, curtains, and other treatments can also be effective, and can be detailed in such a way that there is no damage to the original building. In all cases the appropriate treatment will depend on the type and location of the window.

NOT RECOMMENDED

- Installing new windows, including frames, sash, and muntin configurations, that are incompatible with a building's original appearance or obscure, damage, or destroy features.
- A new building use that will require the addition or blocking of windows on primary elevations or in any location that is highly visible and will compromise the building's historic character.
- Constructing new interior walls, partitions, or floors that intersect windows, damage their fabric on the interior, or create a negative impact on the windows' appearance from the exterior.
- Removing original windows partially or completely or damaging them to install through-wall mechanical equipment or vents.

Windows

Entrances & Porches

Of the wood buildings, only the Theater and Battle Simulation Building have porches. Because the buildings are relatively unornamented, the porches are very important in defining the overall character of the buildings. The porches are one-story, and span the full length of the main elevations. The porches are simple in both design and construction; they have shed roofs supported by wood posts, and the floors of the porches are concrete.

The porches serve as transitional spaces from the outside that help to keep the building clean and protect interior finishes. East Garrison porches, which are built of wood, require regular but low-impact maintenance.



The simplicity of porches at the East Garrison is reflective of the utilitarian nature of the East Garrison buildings and should be maintained.

Entrances & Porches

Identify, Retain, & Preserve

RECOMMENDED

- Identify, retain, and preserve porches and their functional and decorative features, such as posts, open ceilings, and concrete floors.
- Retain and preserve primary entrances even if they no longer provide primary pedestrian access to the structure.

NOT RECOMMENDED

- Removing or radically changing entrances and porches that are important in defining the overall character of the building, such that the character is diminished.
- Stripping entrances and porches of traditional material.
- Removing a porch because the building has been reoriented to accommodate a new use.
- Cutting new entrances on a primary elevation.
- Altering utilitarian or secondary entrances so they appear to be formal entrances by adding elaborate doors, fanlights, or sidelights.

Protect & Maintain

RECOMMENDED

- Protect and maintain the wood and other materials of entrances and porches through appropriate surface treatments, such as cleaning, rust removal, limited paint removal, and reapplication of protective coating systems.
- Evaluate the overall condition of materials to determine whether repairs to entrance and porch features will be necessary.
- Identify porch maintenance problems caused by general wear, improper roof drainage, or by inappropriate changes and find solutions that are compatible with the original features.

NOT RECOMMENDED

- Failing to provide adequate protection to materials on a cyclical basis, such that deterioration of entrances and porches results.
- Failing to undertake adequate measures to ensure the protection of historic entrances and porches.

Repair

RECOMMENDED

- Repair entrances and porches by reinforcing the historic materials.
- Repair deteriorated elements of porches, such as wood posts, rafters, or clay tiles, rather than replacing the entire porch. In many cases, only a small part of an element needs to be replaced, such as a single rafter, instead of the entire roofing system.
- Improve the structural capacity of a porch, where necessary, by adding additional concealed supports and shoring existing members, rather than replacing entire structural systems.

NOT RECOMMENDED

- Replacing an entire entrance or porch when the repair of materials and limited replacement of parts are appropriate.
- Using a substitute material for the replacement parts that does not have the appearance of the surviving parts of the entrance and porch or that is physically or chemically incompatible.

Replace

RECOMMENDED

- Replace in-kind an entire entrance or porch that is too deteriorated to repair – if the form and detailing are still evident – using the physical evidence as a model to reproduce the feature. If using the same kind of material is not technically feasible, then compatible substitute material may be considered.
- Give careful consideration to hardware, security equipment, signage, and lighting, so as not to detract from the original features.

NOT RECOMMENDED

- Removing an entrance or porch that is beyond repair and not replacing it, or replacing it with a new entrance or porch that does not have the same appearance.
- Changing the traditional doors, door openings, surrounds, hardware, or other original features, or changing the location of the doors.

Entrances & Porches

Design for Missing Traditional Features

RECOMMENDED

- Use pictorial and physical documentation to guide the design of missing features. Other Fort Ord buildings of the same type may be used as models.

NOT RECOMMENDED

- Creating a historic appearance because the replaced entrance or porch is based on insufficient pictorial and physical documentation.
- Introducing a new entrance or porch that is incompatible in size, scale, materials, or color.

Alterations & Additions for New Use

RECOMMENDED

- Design enclosures for traditional porches only when required by the new use in a manner that preserves the traditional character of the building. This can include using large sheets of glass and recessing the enclosure wall behind existing posts.
- Design and install additional entrances or porches only when required for a new use in a manner that preserves the traditional character of the buildings (e.g., limiting such alterations to secondary elevations).
- Because the buildings are utilitarian, take particular care that new elements will not be mistaken for traditional elements.
- Retain the ceremonial functions of an original primary entrance, even when traffic patterns have shifted. Rear entrances frequently become the primary entrance, usually as a result of a change in the vehicular access to a building.

NOT RECOMMENDED

- Enclosing porches in a manner that results in a diminution or loss of traditional character (e.g., using solid materials, such as wood, stucco, or masonry).
- Installing secondary service entrances and porches that are incompatible in size and scale with the traditional building, or that obscure, damage, or destroy original features.
- Introducing new elements to the utilitarian buildings that disregard the unornamented and simple nature of the original entrances and porches.
- Changing doors and entry details or changing the location of original doors and entries.

Entrances & Porches

Additions

An attached exterior addition to an existing wood building will expand its profile. Because such expansion has the capability to radically change the historic appearance, an exterior addition should be considered only after it has been determined that a new use cannot be met successfully by altering non-character-defining interior spaces. If a new use cannot be met in this way, an attached exterior addition is usually an acceptable alternative. New additions should be designed and constructed so that the character-defining features of the historic building are not radically changed, obscured, damaged, or destroyed in the process. New design should always be clearly differentiated so that the addition does not appear to be part of the historic resource. Each style, whether historic or contemporary, has its own design vocabulary, and successfully designed additions will reflect the inherent differences of individual styles.

Additions to existing East Garrison buildings should be considered as a last resort, after all other alternatives have proved inadequate. Additions to many of the buildings at the East Garrison should be undertaken with great care. Many of the buildings, such as the Mess Halls and Latrines, are bordered on two opposing sides by public roadways, and, as a result, all facades are prominently visible and are character-defining features. In addition, most of the buildings are a standardized type, and changes to one could alter the uniformity and relationship of the buildings of the group – one of the most important character-defining features at the East Garrison. The symmetry of the majority of the buildings should also be a major consideration when designing additions.

An addition should be compatible with the historic structure. A new addition may be made more compatible by: being architecturally subordinate, constructed of the same materials, designed to emphasize the original structure's massing, and/or to repeat the fenestration pattern. At the same time, character-defining features must be preserved and the new addition must be differentiated from the existing structure. However, even if sensitively designed, an addition can still easily disrupt the original cohesiveness; therefore, the necessity of any addition should be carefully considered.

Additions

Design Guidelines

RECOMMENDED

- Place functions and services required for the new use in non-character-defining interior spaces rather than installing a new addition.
- Evaluate whether the proposed use of a building is appropriate. Consider an alternative use if the proposed use requires a new exterior addition, or alter the building program to better meet the existing configuration of the building.
- Consider the impact of an addition on the attached building, surrounding buildings, and buildings of the same type.
- Take into account the context of the East Garrison as a whole. Design additions that are compatible with the larger context, but that also respond to the immediate surroundings and the building-type group. Locate necessary attached or detached additions in less sensitive zones of the cultural landscape, in inconspicuous areas of the site. An addition in the back of a particular building (like the Latrines and Mess Halls) may still be perceived in the setting due to the system of roadways at the East Garrison where there are many vantage points.
- Integrate a new addition into the building and the site as a whole. Preserve the natural features of the site. Pay particular attention to existing trees and grading. Address the change of circulation routes to and around the buildings. Maintain the original sense of arrival and entry.
- Identify whether a building is part of a group of buildings of the same type. Consider how a new addition will affect the whole group. Maintain the uniformity and character of the group.
- Examine the stylistic complexity of the building to make informed decisions about changes. The East Garrison buildings have simple detailing and massing. Design of an even more restrained addition requires special consideration and calls for a creative solution so as not to obscure the already understated character-defining features of the original.

NOT RECOMMENDED

- Expanding the size of the historic building by constructing a new addition, when the new use could be met by altering non-character-defining interior space.
- Designing and constructing new additions that result in the diminution or loss of the historic character of the resource, including its design, materials, workmanship, location, or setting.
- Constructing “temporary” additions for permanent functions, as opposed to carefully planned and designed additions that have a potential to become part of the history of a building and contribute to its complexity.
- Demolishing any part of the original building to make room for an addition.
- Imitating a historic style or period of architecture in new additions, especially for contemporary uses, such as drive-in banks or garages.
- Altering the character and the perception of the original building by placing an addition where it is highly visible (e.g., in front of the building, on a character-defining primary elevation, or in a place where it will be highly visible from roadways).
- Using the same wall plane, roof line, cornice height, materials, siding lap, or window type to make additions appear to be part of the historic building.
- Imitating exactly the materials of the historic structure, architectural details, and the building form. A new addition should be compatible, but should not be an exact imitation of an original structure.
- Contrasting in a manner that overpowers the architectural features of an existing building. This is particularly important since the buildings at the East Garrison are relatively simple in detail.
- Contrasting materials inappropriately, such as a brick addition to a stuccoed building. Brick is usually considered a more substantial and refined construction material than stucco; it is historically rare to find examples of brick additions to stucco or concrete structures.

Design Guidelines (cont'd)

RECOMMENDED

- Design new additions in a manner that makes clear what is historic and what is new. Allow the historic building to predominate. Reflect the original simple rectangular massing of the existing building. Like the historic buildings, the addition roofs should be low-pitched gables.
- Distinguish between new and existing elements. This may be accomplished through the use of contrasting materials appropriate for the original period of construction and the scale of the structure. For example, a small wood-sided addition to a moderately-sized stucco or concrete building provides contrasting texture and form.
- Construct a new addition to minimize the loss of historic materials and so that character-defining features are not obscured, damaged, or destroyed. Design an addition so that the impact on significant features is minimized. Where the existing building joins the new addition, preserve existing exterior details, even though they will occur on the new interior. Limit the size and number of new openings between old and new to minimize the destruction of historic fabric. Any effect of the new structure on the existing should be reversible. If an addition is removed in the future, the essential form and integrity of the original structure should remain unimpaired. Locate an attached exterior addition at the rear or on an inconspicuous side of a historic building, and limit the size and scale of the addition in relation to the historic building.
- Consider setbacks and reveals in the wall or roof plane to differentiate the addition from the existing building. The setback could become a connector that could help minimize the impact of an addition on the existing structure.
- Provide compatibility in a plan and elevation. Pay attention to interior features at transitions from old to new, such as floor level changes and variations in ceiling height.

NOT RECOMMENDED

- Attaching a new addition so that the character-defining features of the historic building are obscured, damaged, or destroyed.
- Designing a new addition so that size and scale are out of proportion to the historic structure, thus diminishing the historic character.
- Constructing additional stories so that the historic appearance of the building is radically changed, or adding stories. The uniform height of East Garrison's buildings is one of their major character-defining features.
- Duplicating the exact form, material, style, and detailing of the historic building in the new addition so that the new work appears to be part of the historic building.
- Attaching historic detail to an otherwise modern addition in an attempt to historicize it. The ornament should be an integral part of the building design, as opposed to an appliqué.

Additions

Design Guidelines (cont'd)

RECOMMENDED

- Relate existing character-defining lines or elements established by the original building, such as window sizes, cornice lines, or belt courses, to provide continuity with a new addition. For example, if wide moldings are used on the original building, consider using a similar design.
- Allude to the rhythm of existing fenestration; use similar sizes, massing, and scale of details.
- Limit any new excavation or regrading adjacent to historic foundations to avoid undermining the structural stability of the building and potential archaeological resources.

NOT RECOMMENDED

Additions