

ATTACHMENT 4

FINAL EIR



Planning for Success.

FINAL
ENVIRONMENTAL IMPACT REPORT

MONTEREY COUNTY JAIL HOUSING ADDITION

State Clearinghouse # 2013011006

PREPARED FOR
County of Monterey

May 21, 2015

EMC PLANNING GROUP INC.
A LAND USE PLANNING & DESIGN FIRM

301 Lighthouse Avenue Suite C Monterey California 93940 Tel 831-649-1799 Fax 831-649-8399
www.emcplanning.com

FINAL
ENVIRONMENTAL IMPACT REPORT

MONTEREY COUNTY JAIL HOUSING ADDITION

State Clearinghouse # 2013011006

PREPARED FOR
County of Monterey Department of Public Works
168 West Alisal, 2nd Floor
Salinas, CA 93901

PREPARED BY
EMC Planning Group Inc.
301 Lighthouse Avenue, Suite C
Monterey, CA 93940
Tel 831.649.1799
Fax 831.649.8399
kinisonbrown@emcplanning.com
www.emcplanning.com

May 21, 2015

This document was produced on recycled paper.



TABLE OF CONTENTS

1.0	INTRODUCTION	1-1
1.1	Purpose and Organization	1-1
2.0	COMMENTS ON THE DRAFT EIR	2-1
2.1	CEQA Requirements	2-1
2.2	Comments on the Draft EIR	2-1
3.0	REVISED SUMMARY	3-1
3.1	CEQA Requirements	3-1
3.2	Text of Revised Summary.....	3-1
4.0	CHANGES TO THE DRAFT EIR.....	4-1
4.1	CEQA Requirements	4-1
4.2	Changes Made.....	4-1
5.0	MITIGATION MONITORING AND REPORTING PROGRAM..	5-1
5.1	Introduction.....	5-1
5.2	Monitoring Program	5-1
5.3	Monitoring Program Procedures	5-2

Appendices (CD on Inside Back Cover)

Appendix A 2015 Hydrology Study Memo

Appendix B Conceptual Storm Water Control Plan

Tables

Table 1	Commenters and Environmental Issues	2-2
Table 2	Mitigation Monitoring and Reporting Program	5-3

This side intentionally left blank.

INTRODUCTION

I.1 PURPOSE AND ORGANIZATION

The County of Monterey (“County”), acting as the lead agency, has determined that the proposed Monterey County Jail Housing Addition (hereinafter “proposed project” or “project”) may result in significant adverse environmental effects, as defined in CEQA Guidelines section 15064. Therefore, the County had a draft environmental impact report (Draft EIR) prepared to evaluate the potentially significant adverse environmental impacts of the project. The Draft EIR was circulated for public review between Thursday, June 26, 2014 and Wednesday, August 13, 2014. CEQA Guidelines section 15200 indicates that the purposes of the public review process include sharing expertise, disclosing agency analysis, checking for accuracy, detecting omissions, discovering public concerns, and soliciting counter proposals.

This Final EIR has been prepared to address comments received during the public review period and, together with the Draft EIR, constitutes the complete Monterey County Jail Housing Addition EIR. This Final EIR is organized into the following sections:

- Section 1 contains an introduction to the Final EIR.
- Section 2 contains written comments on the Draft EIR, as well as the responses to those comments.
- Section 3 contains a revised summary of the Draft EIR, identifying the changes in the impacts and mitigation measures resulting from comments on the Draft EIR.
- Section 4 contains the revisions to the text of the Draft EIR resulting from comments on the Draft EIR.
- Section 5 contains the mitigation monitoring program.

This side intentionally left blank.

COMMENTS ON THE DRAFT EIR

2.1 CEQA REQUIREMENTS

CEQA Guidelines section 15132(c) requires that the Final EIR contain a list of persons, organizations, and public agencies that have commented on the Draft EIR. A list of the correspondence received during the public review period is presented below.

CEQA Guidelines sections 15132(b) and 15132(d) require that the Final EIR contain the comments that raise significant environmental points in the review and consultation process, and written response to those comments.

2.2 COMMENTS ON THE DRAFT EIR

The following correspondence was received during the public review period on the Draft EIR:

- California Office of Planning & Research, State Clearinghouse (August 7, 2014)
- Monterey Bay Unified Air Pollution Control District (August 13, 2014)
- L+G, LLP Attorneys at Law (August 27, 2014)

A copy of each correspondence received during the public review period for the Draft EIR is presented on the following pages. Numbers along the left-hand margin of each comment letter identify individual comments to which a response is provided. Responses are presented immediately following each letter.

[Table 1, Commenters and Environmental Issues](#), on the follow page present a summary of the issues in the comment letters.

Table 1 Commenters and Environmental Issues

	California Office of Planning & Research, State Clearinghouse	Monterey Bay Unified Air Pollution Control District	L+G, LLP Attorneys at Law
No Comments on Environmental Issues	✓		
Aesthetics			✓
Air Quality		✓	
Biological Resources			
Cultural Resources			
Geology and Soils			
Hydrology and Water Quality			✓
Land Use and Planning			
Noise			
Transportation and Traffic			
Utilities and Service Systems			
Alternatives			

Source: EMC Planning Group 2015



Edmund G. Brown Jr.
Governor

STATE OF CALIFORNIA
Governor's Office of Planning and Research
State Clearinghouse and Planning Unit



Ken Alex
Director

August 7, 2014



Paul H. Greenway
Monterey County
168 West Alisal Street, 2nd Floor
Salinas, CA 93901

Subject: Monterey County Jail Housing Addition
SCH#: 2013011006

Dear Paul H. Greenway:

1

The State Clearinghouse submitted the above named Draft EIR to selected state agencies for review. The review period closed on August 6, 2014, and no state agencies submitted comments by that date. This letter acknowledges that you have complied with the State Clearinghouse review requirements for draft environmental documents, pursuant to the California Environmental Quality Act.

Please call the State Clearinghouse at (916) 445-0613 if you have any questions regarding the environmental review process. If you have a question about the above-named project, please refer to the ten-digit State Clearinghouse number when contacting this office.

Sincerely,

Scott Morgan
Director, State Clearinghouse

**Document Details Report
State Clearinghouse Data Base**

SCH# 2013011006
Project Title Monterey County Jail Housing Addition
Lead Agency Monterey County

Type EIR Draft EIR

Description The proposed project will involve new building construction and expansion of the existing Monterey County Adult Detention Facility to accommodate 576 additional beds and associated program space for inmates housed in the detention facility. This project will increase the design (rated) bed capacity from 825 to 1,401 beds. The proposed project will be constructed in one phase. The expansion will be constructed at the southwest corner of the existing detention facility property on a portion of the existing staff parking lot and a fenced grassy area and will consist of two buildings. The main building would be a 50-foot tall, stacked structure with housing units that have cells on the main floor and on a tier level. A second smaller, single-level building located south of the main structure will be designated for administrative purposes.

Lead Agency Contact

Name Paul H. Greenway
Agency Monterey County
Phone 831 647 7748 **Fax**
email
Address 168 West Alisal Street, 2nd Floor
City Salinas **State** CA **Zip** 93901

Project Location

County Monterey
City Salinas
Region
Lat / Long 36° 41' 57.6" N / 121° 37' 50" W
Cross Streets East Laurel Drive, Constitution Blvd, Natividad Road
Parcel No. 003-851-034-000
Township **Range** **Section** **Base**

Proximity to:

Highways Hwy 101
Airports No
Railways Amtrak
Waterways Gabilan Creek
Schools 8 ES/MS/HS/AS
Land Use Public/Semipublic (City of Salinas); Public/Semipublic (PS) (City of Salinas)

Project Issues Air Quality; Archaeologic-Historic; Biological Resources; Geologic/Seismic; Noise; Public Services; Sewer Capacity; Solid Waste; Traffic/Circulation; Water Quality; Water Supply; Cumulative Effects

Reviewing Agencies Resources Agency; Department of Conservation; Department of Fish and Wildlife, Region 4; Office of Historic Preservation; Department of Parks and Recreation; Department of Water Resources; Office of Emergency Services, California; California Highway Patrol; Caltrans, District 5; Department of Housing and Community Development; Air Resources Board; Regional Water Quality Control Board, Region 3; Native American Heritage Commission

Date Received 06/20/2014 **Start of Review** 06/23/2014 **End of Review** 08/06/2014

Response to Letter I from Scott Morgan, Director, California Office of Planning and Research, State Clearinghouse (August 7, 2014)

1. The letter acknowledges that the County of Monterey has complied with the State Clearinghouse review requirements for draft environmental documents pursuant to CEQA. The letter did not raise any environmental issues. Therefore, no response is necessary.



MBUAPCD

Monterey Bay Unified Air Pollution Control District
Serving Monterey, San Benito, and Santa Cruz Counties

24580 Silver Cloud Court
Monterey, CA 93940

PHONE: (831) 647-9411 • FAX: (831) 647-8501

August 13, 2014

Submitted Via E-mail

County of Monterey RMA - Public Works
168 W. Alisal Street
Salinas, CA 93901



SUBJECT: Monterey County Jail Housing Addition (PD 080640) – Draft Environmental Impact Report

To Whom it May Concern:

Thank you for providing the Monterey Bay Unified Air Pollution Control District (Air District) the opportunity to comment on the above-referenced document. The Air District has reviewed the document and has the following comments:

- 1 • Please correct the formatting errors/missing text in the last paragraph on page 3-8, Table 5 on page 3-9, Table 7 on page 3-15, and the first two paragraphs on page 3-16. For example, in Table 5 there are pollutants missing in the first column.
- 2 • Please identify whether any new stationary sources, such as a boiler or generator, would be part of the proposed project. These types of stationary sources will be required to obtain a permit from the Air District. Please contact the Air District if you have questions about permitting at (831) 647-9411.

Please let me know if you have questions, I can be reached at (831)647-9418 ext. 227 or aclymo@mbuapcd.org.

Best regards,

Amy Clymo
Supervising Air Quality Planner

**Response to Letter 2 from Amy Clymo, Supervising Air Quality Planner,
Monterey Bay Unified Air Pollution Control District (August 13, 2014)**

1. A production error resulted in text that was subscript or superscript, or attached to subscript or superscript, being dropped from sections of the EIR as identified above. The text has been corrected. Refer to Section 4.0 Changes to the Draft EIR. These are minor textual clarifications and do not change the conclusions in the EIR.
2. The proposed project will include a new generator. As this is considered a new stationary source, the County will be required to obtain a permit from the Air District.



Jeffery R. Gilles
Dennis C. Beougher
Patrick S. M. Casey
E. Soren Diaz
Aaron Johnson
Stephen H. Kim
Gavin E. Kogan
Ronald A. Parravano
Jason S. Retterer
Paul A. Rovella
Bradley W. Sullivan
James W. Sullivan

August 27, 2014

Via Mail and E-mail

County of Monterey Resource Management Agency
Department of Public Works
Attn: Paul H. Greenway, Assistant Director of Public Works
168 West Alisal, 2nd Floor
Salinas, CA 93901

RE: Comments on Draft EIR for Jail Housing Addition Project

Dear Mr. Greenway:

Our office represents Higashi Farms, Inc. and Henry Hibino Family Farms, LLC, who own and actively farm the majority of the roughly 480-acres of Carr Lake, which is located just south and downstream of the proposed Jail Housing Addition project ("Project"). We are writing specifically to provide comments on the Draft Environmental Impact Report ("DEIR") for the Project.¹ The Project, as described in the DEIR, consists of the construction and operation of a single phase, 576 bed, jail housing addition building and a second administrative building that includes administrative support spaces on an approximately 2.6 acre portion of Monterey County Adult Detention Facility site, located at 1410 Natividad Road in the City of Salinas.

I. Introduction

① **A. The Well Documented Impacts of Upstream Development on Carr Lake Due to Undersized Drainage Facilities Downstream of Carr Lake.**

As noted in the City of Salinas 2002 General Plan, Carr Lake is an historic lake bed that lies roughly 1,000 feet south of the project site. Carr Lake, which has been drained and used as agricultural lands for much of the last century, captures runoff from approximately 64,000 acres (101 square miles) of watershed that drains through Carr Lake.² Three creeks

¹ While the public comment period officially ended on August, 13, 2014, we received a 2-week extension of time to submit comments on the DEIR based on the County's failure to provide timely notice of the Notice of Availability of the DEIR despite our written request for notice of such documents. This extension is documented in a letter from Mr. Donald Searle to me, dated August 11, 2014.

² 2002 City of Salinas General Plan, Safety Element, p. S-25

Serving California's Central Coast

- **SALINAS** 318 Cayuga Street / Salinas, CA 93901 / TEL 831.754.2444 / FAX 831.754.2011
 - **HOLLISTER** 530 San Benito Street, Suite 202 / Hollister, CA 95023 / TEL 831.630.9444 / FAX 831.630.5935
 - **MONTEREY** 270 El Dorado Street / Monterey, CA 93940 / TEL 831.717.4995 / FAX 831.717.4996
 - **PASO ROBLES** 745 Pine Street / Paso Robles, CA 93446 / TEL 805.226.0626
 - **KING CITY** 218 Bassett Street / King City, CA 93930 / TEL 831.385.0900
- TOLL FREE 888.757.2444 / www.LG-Attorneys.com

1
(cont.)

confluence in Carr Lake: Gabilan Creek to the north, Natividad Creek, and Alisal Creek to the south.³

A 2007 study of Carr Lake⁴ documented the history of Carr Lake, including the construction of the currently undersized reclamation ditch and downstream drainage facilities that continue to adversely affect agricultural production at Carr Lake, which has been actively farmed for approximately 100 years. The study stated in pertinent part:

Carr Lake is a natural depression that captures runoff from 260 km² of watershed (Fig 1.1). The Lake functions as a thru-flow detention basin, where flows exiting the lake are controlled by the lake's water elevation. Drainage out of the lake is regulated by a double 8 ft x 8 ft box culvert under the Main Street bridge. ***The box culvert itself is undersized compared to others upstream and downstream of it and therefore restricts peak flows and downstream flooding*** (SWCCE, 2002). In addition, the culvert is usually impacted by accumulated sediments which require regular dredging (Casagrande and Watson, 2006a).

Beneath the box culvert is a 36-inch diameter pipe that is used to convey water during low flow periods. When stream flow is in excess of the pipe's capacity, water is impounded until it reaches the bottom of the overriding box culvert. This generally results in partial flooding of the lake during most storm events. Figure 2.1 shows the flood patterns and water elevations in the lake during a variety of runoff conditions. During a 2-year event, more than half of the lake bottom is flooded. This has been observed several times since 2000 (e.g. cover photo) and has been a common condition for some time (Bechtel Corp, 1959). During a ten year event, nearly 90% of the lake bed is inundated and in a 25 year event, the entire lake and some areas outside including the Sherwood Lake Mobile Home Park are inundated (Fig 2.1 C). At 100 year event, water elevations could spill onto Highway 101 and into parts of downtown Salinas (SWCCE, 2002; Cameron et al. 2003).

In summer, each of the channels in the lake has surface water due to upstream sources and local tile drains within the lake. The Lake's landowners install a seasonal earthen dam to restrict water from Gabilan Creek flowing up Natividad Creek (Cameron et al. 2003).

³ Id.

⁴ Joel M. Casagrande, Fred Watson, PhD, Central Coast Watershed Studies, The Carr Lake Project: Potential Biophysical Benefits of Conversion to a Multiple-Use Park, Dec. 12, 2007 (Pertinent Excerpts of the Study are attached as **Exhibit B**)

1

(cont.)

The same study also documents the most recent flooding history:

Since its construction in 1920, *the Reclamation Ditch system has experienced significant flooding due to its limited capacity and the overall expansion of the urban areas upstream.* During the winter of 1951/52, the Reclamation Ditch was unable to handle “record flows”, which resulted in significant flooding between the Alisal neighborhood and downtown Salinas (CDPHBSE, 1952). The 1995 and 1998 El Nino events resulted in substantial flooding and property damage throughout the northern Salinas Valley, including Carr Lake and the Reclamation Ditch system. During this event, the City of Salinas received 20.1 inches of rainfall, approximately 6 inches above the annual average. Rainfall in the southern half of the Salinas Valley was more substantial (25.3 inches in King City) which caused the Salinas River to peak at 95,000 cfs at the Spreckels gage – the highest on record. The lower portions of the Gabilan Watershed were most impacted by floodwaters from the Salinas River which overtopped its banks at several locations sending river water onto the flat areas (Blanco Drain sub-watershed) between the Reclamation Ditch and the Salinas River (Fig 2.2). This caused Tembladero Slough and the Reclamation Ditch (already at or near capacity) to backup, flooding both the Espinosa and the Merritt Lake drainages to the north. Further east, Carr and Heinz Lakes were partially filled due to heavy runoff from the Gabilan, Natividad and Alisal drainages (Fig 2.2).

During the winter of 1998, the city of Salinas received 30.1 inches of rain (second highest total on record). Gabilan Creek peaked at 1,035 cfs, a 25-year event and the highest level since records began in 1970. Carr Lake reached an elevation of 42.9 feet, flooding the Sherwood Lake Mobile Home Park for 11 days and reaching 0.1 feet from flooding a home situated on one of the raised “island” areas within the lake bed. While physical property damage was not significant, damage to fields and the drainage system itself were substantial.

A separate report, which was prepared for the Monterey County Water Resources Agency, called the “Reclamation Ditch Watershed Assessment and Management Strategy” corroborated the 2007 study:

In summary, flooding remains an issue in the Reclamation Ditch Watershed. The continued increase in impervious surfaces has led to increased discharge and faster runoff response throughout the watershed has resulted in the increase in flood damage throughout the watershed. Most of the damage

① | caused from flooding in average years occurs on farmlands, of which most lies
(cont.) | within the historical lake bottoms and downstream of the City of Salinas.⁵

B. Summary of Comments

② | Based on our review of the DEIR and supporting documents, we have concluded that the DEIR does not comply with the requirements of the California Environmental Quality Act (“CEQA”). In sum, the DEIR improperly fails to analyze certain impacts based on the conclusion of an initial study that analyzed a different project and fails to disclose, analyze and mitigate the Project's impacts on hydrology/drainage patterns. In addition, the DEIR's analyses of cumulative impacts and Project alternatives fail to meet the standards of CEQA. Thus, the DEIR does not fulfill its function as an informational and decision-making document. These issues are discussed more fully below.

③ | We have prepared these comments with the assistance of Peter Hasse, M.S., P.E. and Principal Engineer of Fall Creek Engineering, Inc. (“FCE”) Mr. Hasse’s comments and resume are attached as **Exhibit A**. Please note that these experts' comments supplement the issues addressed below and should be responded to separately.

II. The DEIR Improperly Relies On The Initial Study’s Analysis Of A Different Project To Conclude That Numerous Project Impacts Are Less Than Significant And Require No Further Analysis In The DEIR.

④ | The DEIR states on page 1-7 that the an initial study was prepared for the “proposed project” and concluded that the project would have no environmental effect of a less than significant environmental effect on the areas of aesthetics, agriculture, hazards/hazardous materials, land use planning, mineral resources, populations/housing, public services, and recreation. Accordingly, the DEIR does not analyze the project’s impact on these resources. However, the initial study that is attached as Appendix A to the DEIR and purports to provide the supporting analysis and evidence to justify not analyzing these impacts is based on a different project. Specifically, the initial study analyzed a two phase project with a different building and parking footprint that is now proposed in the DEIR. While some of the impacts may indeed be similar to the impacts of the proposed impacts, other impacts, such as aesthetics, for example, may be different and have not been fully explored or analyzed. As it relates specifically to aesthetics, the initial study did not analyze the impacts of the scale and massing of a 50 foot tall, two-story structure to house all 576 beds. Instead, the initial study analyzed the impact of a predominantly one-story structure. Accordingly

⑤ |

⁵ Central Coast Watershed Studies, *Final Report - Monterey County Water Resources Agency - Reclamation Ditch Watershed Assessment and Management Strategy: Part A Watershed Assessment*, p. 84 (Pertinent excerpts from this Study, which relate to flooding history, are attached as **Exhibit C**)

6 and since the Project has fundamentally changed from the initial proposal, the County must reassess the environmental impacts it initially dismissed as insignificant in the initial study and determine whether the impacts of the current project are inconsistent with the initial study's findings. See 14 Cal Code Regs §15143.

III. The DEIR's Conclusion that Hydrology Impacts Would Be Less than Significant Is Inadequate.

A. The DEIR's Description of the Environmental Setting Fails to Comply with CEQA.

7 The DEIR fails to include a proper description of the environmental setting to fully understand the extent and magnitude of this Project's impact on existing drainage conditions. Under CEQA, an EIR's description of the environmental setting must be sufficiently comprehensive to allow the project's significant impacts "to be considered in the full environmental context." 14 Cal Code Regs §15125(c). As the California Supreme Court has noted, to provide the impact assessment that is a fundamental goal of an EIR, the EIR "must delineate environmental conditions prevailing absent the project, defining a 'baseline' against which predicted effects can be described and quantified." *Neighbors for Smart Rail v Exposition Metro Line Constr. Auth.* (2013) 57 C4th 439, 447.

8 In this case, the DEIR's discussion of existing drainage conditions is captured in one small paragraph that is limited to describing drainage conditions on-site. Specifically, the DEIR generally describes the direction that run-off flows on the site, notes that the run-off is collected in a system of inlets and pipes that discharge into a grass drainage swale, which ultimately conveys the flows to a large 48-inch pipe that discharges water off-site. The DEIR fails to describe where the run-off flows once it exits the site and provides no information on the size, capacity, or location of off-site drainage facilities and whether these facilities are appropriately sized to accommodate off-site drainage flows. This information is critically important, particularly in this portion of the City, which has a long history of downstream flooding.

9 In addition, the DEIR provides no information on Carr Lake in the environmental setting, which is a startling omission, in light of the well documented flooding that has occurred in the Carr Lake area and its proximity to the Project site. Not only must the DEIR include a thorough assessment of the capacity of downstream drainage facilities to accommodate the drainage flows that will be exiting the Project site during storm event and from on-site irrigated landscaping, it should also specifically address whether and to what extent these increased flows have the potential to increase flooding at Carr Lake.

B. The DEIR's Contains Insufficient Analysis to Support Its Conclusion that Project's Drainage Impacts Would be Less Than Significant.

1. Simply Stating that the Project Will Comply with State and County Storm Water Regulations Is Inadequate to Demonstrate that Project Will Have Less Than Significant Impacts.

The DEIR concludes that the project would have a less than significant impact on existing hydrology and drainage during construction and once the project is operational because it will comply with existing regulatory requirements, which are briefly summarized in the DEIR.

10 A determination that regulatory compliance will be sufficient to prevent significant adverse impacts must be based on a *project-specific analysis* of potential impacts and the effect of regulatory compliance. In *Californians for Alternatives to Toxics v Department of Food & Agric.* (2005) 136 Cal.App.4th 1, the court set aside an EIR for a statewide crop disease control plan because it did not include an evaluation of the risks to the environment and human health from the proposed program, but *simply presumed that no adverse impacts would occur from use of pesticides in accordance with the registration and labeling program of the California Department of Pesticide Regulation.* (See also *Ebbetts Pass Forest Watch v Department of Forestry & Fire Protection* (2008) 43 Cal.4th 936, 956 [fact that Department of Pesticide Regulation had assessed environmental effects of certain herbicides in general did not excuse failure to assess effects of their use for specific timber harvesting project]). The DEIR takes a similar approach to assessment of the Project's hydrology and drainage impacts. The DEIR simply presumes that compliance with the County and State regulations relating to the preparation of storm water management plans will ensure that the Project will not adversely affect drainage conditions or increase flooding potential. While the DEIR attempts to provide site specific details of drainage features that will be implemented to comply with these requirements, as noted below, the "conceptual drainage plan" that is discussed in the DEIR was prepared for a different project with a different building footprint.

11 In addition, the DEIR assumes that a key component of compliance with these regulatory requirements (e.g. the County's Municipal NPDES Permit), on-site retention, which is incorporated into the conceptual drainage plan and required under the will ensure that project's impacts would be less than significant. For example, the DEIR notes that the final drainage control plan will "identify Low Impact Design measures such as bioretention areas or infiltration zones" and "in ground retention structures to control the storage and rate of release not to exceed present levels." (DEIR, p. 3-57) While on-site retention might be appropriate on some sites to reduce the discharge of storm water off-site, the

11

(cont.)

Geotechnical Report concludes that on-site retention will not be feasible for this particular project:

The soil encountered in the upper 10 feet generally consists of lean and fat clays. It is our opinion ***that on-site retention of collected storm drainage is not feasible given low percolation rates of the in-situ soil***” (p. 8. Emphasis Added.)

Accordingly, the DEIR’s conclusion that compliance with regulatory standards and the drainage plan will ensure that project impacts would be less than significant is not supported by substantial evidence.

12

In addition, because compliance with these regulatory standards, which include the preparation of future plans (e.g. a Storm Water Pollution Prevention Plan and a post-construction final on-site storm water drainage plan), are not incorporated into the project as mitigation measures or conditions of approval, there is no guarantee or assurance that the County will actually prepare and implement the required plans. In other words, because these plans are basically incorporated into the Project as regulatory requirements to purportedly avoid or minimize drainage impacts, the Project’s drainage impacts would be less than significant. In the recent case, *Lotus v. Department of Transportation* (2014) 223 Cal.App.4th 645, the Court of Appeal concluded that an EIR for a highway construction project violated CEQA where it effectively incorporated proposed mitigation measures into the project, rather than separately identifying and analyzing them as actual mitigation measures. The Court of Appeal explained:

The failure of the EIR to separately identify and analyze the significance of the impacts to the root zones of old growth redwood trees before proposing mitigation measures is not merely a harmless procedural failing. Contrary to the trial court’s conclusion, this short-cutting of CEQA requirements subverts the purposes of CEQA by omitting material necessary to informed decision-making and informed public participation. It precludes both identification of potential environmental consequences arising from the project and also thoughtful analysis of the sufficiency of measures to mitigate those consequences. *Id.* at 658.

13

2. Compliance with the Conceptual Drainage Plan that Was Prepared For a Different Project Is Not Evidence that This Project will Have a Less Than Significant Drainage Impact.

13
(cont.)

The DEIR's conclusion that the Project would purportedly have a less than significant drainage impact is also based on hydrologic analysis that was prepared for a different project. The hydrologic analysis set forth in the BKF Monterey County Jail Housing Addition Project – Hydrology Study, dated August 19, 2013, and attached as Appendix E to the DEIR ("Hydrology Study") is based on a different, two phase, project that was initially described in the 2013 Initial Study, and is no longer being contemplated (see p. 2, Figures 2 & 3). The conceptual storm water treatment plan (Figure 4) and conceptual utility plan (Scheme 4) that are attached to the Hydrology Study are also based on this same two-phase project and building layout. However, as the 2014 DEIR explains in the Project Description, "the project will be constructed in one phase" and the site plan in the DEIR appears to show two buildings connected by a corridor in a configuration that is different than the site plan that was analyzed in the Hydrology Study (See Figure 4). Accordingly, the Hydrology Study and its related analysis must be revised and recirculated to reflect the current Project site plan to fully understand and address the effectiveness of the Project's drainage plan to reduce impacts, which is the conclusion of the DEIR. Importantly, it appears that the two-phase project analyzed in the Hydrology Study includes a larger percentage of pervious coverage than the Project described and depicted in the DEIR. Therefore, the Project described in the DEIR will have a greater impact on area drainage and hydrology.

14

FCE conducted a peer review of the DEIR's Hydrology analysis and identified numerous deficiencies in its analysis. (See **Exhibit A**). According to FCE, the detention system that is described in the Hydrology Study "is substantially smaller than what will be required to comply with the Regional Water Board's requirements," which means that a greater volume of storm water will be discharged off-site. FCE further explains, among other deficiencies identified in their independent assessment of the Project's hydrologic impacts, that even controlling off-site discharges to a 2-year event could create impacts if the downstream channel is not adequately sized or armored, which is the case with drainage facilities downstream of the Project site. Accordingly, the DEIR's conclusion is not supported by substantial evidence and fails provide sufficient information regarding the Project's significant drainage impacts. The County must undertake a more thorough review and analysis of the capacity of off-site drainage facilities in order to conclude that the Project will have a less than significant impact relating to the alteration of existing drainage facilities or potential off-site flooding impacts.

3. The DEIR'S Analysis of Cumulative Hydrology and Drainage Impacts is Inadequate.

The purpose of an EIR's cumulative impacts analysis is to avoid considering projects in a vacuum, because failure to consider cumulative harm may risk environmental

14
(cont.)

disaster. *Whitman v Board of Supervisors* (1979) 88 Cal.App.3d 397, 408. Without this analysis, piecemeal approval of several projects with related impacts could lead to severe environmental harm. *San Joaquin Raptor/Wildlife Rescue Ctr. v County of Stanislaus* (1994) 27 Cal.App.4th 713, 720; *Las Virgenes Homeowners Fed'n v County of Los Angeles* (1986) 177 Cal.App.3d 300, 306. An adequate analysis of cumulative impacts is particularly important when another related project might significantly worsen the project's adverse environmental impacts. *Friends of the Eel River v. Sonoma County Water Agency* (2003) 108 CA4th 859.

15

In this case and despite the well documented conclusion regarding the impact of upstream development on Carr Lake due to the undersized drainage facilities, the DEIR inexplicably concludes that the Project's increase in storm water flows would not result in significant cumulative impact. In fact, the conclusion of at least one EIR for one of the cumulative projects that is listed in the DEIR concluded that the Project would have a significant impact when its contribution of off-site storm water flows are combined with the flows of these other projects. The Final Supplemental EIR that the City of Salinas prepared and certified for the City of Salinas Future Growth Area concluded as follows as it relates to Storm Drainage Impacts:

Future development identified in the Salinas General Plan has the potential to modify the surface runoff generated from the Project area local watershed that is tributary to the receiving waters or adjacent creek systems compared to the natural runoff conditions. This includes the addition of more impervious surfaces, increasing the quantity of local storm water runoff. This condition creates a potentially significant drainage (surface hydrology) impact requiring mitigation.

In general, future urban development in the Project area could potentially result in direct modifications to surface hydrology through several areas that include (1) decreasing the development watershed response time associated with a more hydraulically efficient drainage conveyance system of streets and pipes, (2) increasing runoff volume, (3) reducing infiltration through increased impervious areas, and (4) increasing peak runoff rates. In addition, urban runoff can result in increased concentrations of different constituent pollutants that can result in impacts to water quality. The quantity of runoff can potentially influence the stability of the river process in alluvial stream systems directly related to sediment transport and affect the downstream existing hydrologic operation of Carr Lake.

Even though the Project's incremental contribution of storm water flows may not be significant as the DEIR concludes, when these off-site flows are combined with build-out of

15
(cont.)

the City's Future Growth Area and other nearby projects that are upstream of Carr Lake, including the Salinas Soccer Complex Project, and the Residential Project at Constitution and Independent Boulevard, these flows are significant and mitigation must be identified to address this impact. The DEIR does not include any pertinent information regarding the additional impervious coverage and anticipated storm water flows or drainage impacts that are expected to occur from these others projects to demonstrate that the Project would have a less than significant cumulative drainage impact. This information is critical because as documented above and in the attached FCE analysis, the drainage facilities downstream of this Project simply do not have the capacity to accommodate storm water flows from any upstream "cumulative" projects. For example, according the Salinas Soccer Complex Mitigated Negative Declaration/Initial Study prepared by the same environmental consultant, EMC Planning Group Inc., "the proposed project would add approximately 7.1 acres of impervious area to the site by constructing a building, parking areas and other facilities."⁶ In order to mitigate this cumulative impact, nothing short of increasing the capacity of these facilities will reduce the significant cumulative impacts of this Project and other upstream projects to a less than significant level. If this Project or these other projects are not required to increase downstream drainage capacity, or at least contribute their fair share for the cost of improvements that are required to increase capacity, the inescapable conclusion is that this Project and these other projects will have a significant and unavoidable drainage and hydrology impact.

16

IV. CONCLUSION

The County's DEIR violates CEQA. The Project would result in significant impacts that are either undisclosed, erroneously evaluated or insufficiently mitigated in the DEIR. Accordingly, the County must prepare a revised DEIR to correct these deficiencies, and the revised DEIR must be circulated for public review and comment.

We appreciate the opportunity to comment on the DEIR.

Very truly yours,
L+G, LLP Attorneys at Law



Jason S. Retterer
Enclosures

⁶ See EMC Planning Group Inc., Mitigated Negative Declaration/Initial Study, Salinas Soccer Complex, dated August 7, 2013, p. 66

EXHIBIT A



FALL CREEK ENGINEERING, INC.

Civil • Environmental • Water Resource Engineering and Sciences

Tel. (831) 426-9054

P.O. Box 7894, Santa Cruz, CA 95061

Fax. (831) 426-4932

August 27, 2014

Jason S. Retterer
L+G, LLP
318 Cayuga Street
Salinas, CA 93901
Jason@lg-attorneys.com

Subject: **Review of Hydrologic Impact Assessment
Draft Environmental Impact Report for Monterey County
Jail Housing Addition, Salinas, California**

Dear Jason:

Fall Creek Engineering, Inc. (FCE) reviewed Section 3.6, Hydrology and Water Quality, and Section 4.2, Cumulative Impacts, of the Draft Environmental Impact (DEIR) for the proposed Monterey County Jail House Addition project (Project). FCE also reviewed the technical memorandum (Technical Memorandum) prepared by BFK Engineers entitled "Monterey County Jail House Addition Project – Hydrology Study", dated August 19, 2013, which is the supporting technical document referenced in the DEIR. The purpose of FCE's review was to determine whether the DEIR's conclusions are adequately supported by the evidence relied upon in the DEIR based on our knowledge of the watershed area and the existing drainage infrastructure in this area.

FCE has completed several engineering studies and drainage improvements projects in the vicinity of the subject project and has a good technical understanding of the drainage issues in Carr Lake and the Reclamation District. FCE designed the Natividad Creek Stormwater Detention Facility for the City of Salinas, and developed a hydraulic model of the Natividad Creek and Carr Lake Basin to evaluate drainage and hydrologic conditions in this watershed area. FCE has also modeled and designed the Reclamation Ditch channel improvement projects along Sherwood and Harrod Drives and has analyzed drainage and hydrologic conditions in the Reclamation Ditch.

Peter Haase, Principal Engineer for FCE conduct this review and has over 29 years of professional experience in civil engineering and in the fields of drainage and hydrology. A copy of Mr. Haase's resume is attached.

FCE has reviewed the DEIR and Technical Memorandum to determine whether the evidence set forth in these documents supports the DEIR's conclusion that the Project falls below the significant thresholds set forth in the DEIR for hydrologic impacts. (See p. 3-54 – 3-55) The DEIR sets forth the following *Standards of Significance*:

- *Substantially alter the existing drainage pattern of the site or area, including through the alteration of the course of a stream or river, in a manner which would result in substantial erosion or siltation on- or off-site;*

- *Substantially alter the existing drainage pattern of the site or area, including through the alteration of the course of a stream or river, or **substantially increase the rate or amount of surface run-off in a manner which would result in flooding on- or off-site**; or*
- *Create or contribute runoff water, **which would exceed the capacity of existing or planned storm water drainage systems** or provide additional sources of polluted run-off.*

In an abbreviated analysis that covers roughly one page, the DEIR concludes that the project would have a less than significant impact as it relates to all of the above significance thresholds. The DEIR's conclusion is based on the project's compliance with County and State storm water regulations, which are generally summarized in the DEIR and the conclusions of the Technical Memorandum. (See pp.s 3-56 – 3-57) The DEIR concludes that the "conceptual drainage plan" described in the Technical Memorandum will "ensure the proposed project does not result [sic] hydrologic impacts associated with drainage." (p. 3-56). We also note the Technical Memorandum states, based on a review of the 10-year old, "City of Salinas Storm Water Master Plan," that the "existing city drainage system functions well." (See p. 1)

Based on our review DEIR's abbreviated analysis, FCE has determined that the DEIR and supporting documents do not fully assess the potential hydrologic impacts associated with the subject project and therefore are inadequate to support the DEIR's conclusion. Until a more comprehensive analysis of hydrologic impacts is undertaken, it is impossible to conclude that this project will not "substantially alter the existing drainage patterns of...the area,...or substantially increase the rate of amount or amount of surface run-off in a manner which would result in flooding...off-site." In addition, it is impossible to conclude that the project would not "contribute runoff water, which would exceed the capacity of existing or planned storm water drainage systems."

Specifically, FCE offers the following comments:

1. The hydrologic analysis set forth in the Technical Memorandum is based on a different, two phase, project that was initially described in the 2013 Initial Study, and is no longer being contemplated (see p. 2, Figures 2 & 3). The conceptual stormwater treatment plan (Figure 4) and conceptual utility plan (Scheme 4) that are attached to the Technical Memorandum are also based on this same two-phase project and building layout. However, as the 2014 DEIR explains in the Project Description, "the project will be constructed in one phase" and the site plan in the DEIR appears to show two buildings connected by a corridor in a configuration that is different than the site plan that was analyzed in the Technical Memorandum (See Figure 4). Accordingly, the Technical Memorandum and its related analysis must be revised and recirculated to reflect the current Project site plan to fully understand and address the effectiveness of the Project's drainage plan to reduce impacts, which is the conclusion of the DEIR. Importantly, it appears that the two-phase project analyzed in the Technical Memorandum includes a larger percentage of pervious coverage than the Project described and depicted in the DEIR.
2. In any event, the Technical Memorandum concludes that under the Phase I of the old project the 100 year return event will increase peak runoff rates from 4.1 cubic feet per second (cfs) to 4.8 cfs, an increase of 0.7 cfs. During the Phase 2 improvements some existing impervious areas will be converted to pervious landscaped areas and the peak

18
(cont.)

runoff rate for the overall site will decrease to 4.4 cfs, which will increase the overall difference by 0.3 cfs. Page 3-56 of the DEIR indicates that the “increase in the peak flow rate for the 100-year storm event of approximately 0.3 cfs.” However, as discussed above the runoff rates presented in the DEIR are based on the Technical Memorandum that presents a phased project that does not represent the plan presented in the DEIR. Therefore, the peak runoff rates presented in the DEIR do not reflect the proposed project.

19

3. The Technical Memorandum indicates that to mitigate the net increase in runoff, the Project must include a detention structure will need to be sized to detain the difference in flow between the existing and the post-development 100 year storm event or 0.7 cfs. However, Page 3-57 of the DEIR indicates that “to comply with the Regional Water Board’s post construction requirements” the “drainage control plan will include a design of the storm water detention facilities to limit the 100-year post development runoff rate to the 2-year pre-development rate”.

The detention system described in the DEIR and technical memorandum is substantially smaller than what will be required to comply with the Regional Water Board’s requirements. The DEIR should provide a more thorough hydrologic analysis to more accurately describe the extent of improvements required for the project and to demonstrate that there is sufficient space on the site to accommodate a large storm water detention facility.

20

4. A storm water detention facility is designed to retain and slowly meter out runoff over a sustained period of time. Although, the State requirements require that peak runoff events are detained and released at the pre-development 2-year design flow, this flow regime can be still be significant if sustained over many hours and can result in downstream erosion of earthen channels. Further, a 2-year flow event can result in bankfull and channel forming flows, and if the downstream channel is not adequately sized or armored, it can be substantially impacted by these flow conditions. A more thorough drainage and erosion potential assessment is required to assess if the project will, or will not, alter downstream drainage facilities, and whether or not mitigation is required to address this impact.

21

5. The Technical Memorandum states that “BFK reviewed the report (City of Salinas Storm Water Master Plan, May 2004) to see if there are any known capacity issues around the Project site. The memo further states that “Section 2.3 of the report states that City staff indicated that the existing city drainage system functions well.”

The project site is located in the Carr Lake watershed, and according to Section 5.2.1. of the City of Salinas’s Storm Water Master Plan (May 2004), “the City’s existing storm drain systems is already operating at its maximum capacity.” The Reclamation Ditch system, which is the receiving water from the project site “does not have capacity to handle additional runoff.” “All new development must construct detention storage as part of the planned development or participate in implementation of the regional detention basins.”

Although, the project is planning to install a storm water detention facility, the project will increase the overall volume of runoff to the City’s storm water system and to the Reclamation Ditch, which are both reportedly at capacity. According to *Standards of*

21
(cont.)

Significance the proposed project may contribute runoff to drainage facilities that are already at capacity, which can be a significant hydrologic impact. A more thorough hydrologic analysis of potential capacity of downstream facilities is required to assess if the project will impact downstream facilities and what mitigation, if any, is required to reduce this impact.

22

6. The DEIR states that since "the project will be required to comply with Monterey County's Municipal NPDES Permit and the Regional Water Board's post construction requirements to ensure that potential impacts associate with drainage would be less than significant, therefore; the contribution of the proposed project to cumulative impacts to hydrology and water quality is not cumulatively considerable and less than cumulatively significant".

County and State requirements impose general design standards for specific projects. However, County and State standards do not require that the project evaluate the potential cumulative downstream impacts associated with hydrology and water quality. As already noted, the project is located in the Carr Lake watershed area, which has significant drainage capacity limitations. The DEIR needs to complete a more thorough assessment of cumulative impacts before it can assess if the cumulative hydrologic impacts are significant or not and this analysis has not been completed.

If you have any questions or require additional information, please contact me at (831) 426-9054 or email me at phaase@fallcreekengineering.com.

Sincerely,



PETER HAASE, M.S., P.E.
Principal Engineer

PETER H. HAASE

EDUCATION

B.S., 1985, Environmental Resource Engineering, Humboldt State University
M.S., 2009, Environmental Systems, International Development and Technology, Humboldt State University

PROFESSIONAL CERTIFICATION

California Registered Civil Engineer, No. C055605

PROFESSIONAL EXPERIENCE

1998-Present. Principal Engineer. Fall Creek Engineering, Inc. Santa Cruz, CA
Specializes in small community water and wastewater system design, surface water hydrology, water resource planning and management, surface and ground water pollution control, and water quality/quantity monitoring system design.

1994-1997. Senior Engineer. Applied Science and Engineering, Inc. Santa Cruz, CA
Project manager and senior engineer on a variety of projects in the areas of surface water hydrology, water resource planning and management, small community water and wastewater system designs, irrigation system evaluation and designs.

1993 – 1994. Consulting Engineer. Municipal Water Agency, County of San Pedro Sula. Honduras, Central America. Independently contracted by the Water Agency to develop a water resources management plan for surface and ground water resources in the county. Developed preliminary water pollution control legislation (this was the first environmental control legislation developed in the country) and a feasibility study for its implementation. Completed a technical study to establish land use controls to protect ground water resources in the region.

1990-1992. Project Engineer (Volunteer). U.S. Peace Corps, Water and Sanitation Project. Honduras, Central America. Job responsibilities included assessment and troubleshooting of rural water systems, project feasibility studies, topographic surveys, system designs, material and cost estimation, execution and management of labor contracts, transportation and construction planning, and construction supervision.

1986-1990. Water Resource Control Engineer. California State Water Quality Control Board, Central Valley Region. Sacramento Office. Responsible for the preparation of State and Federal permits for municipal and industrial wastewater facilities, private and public solid waste landfills. Implemented state underground storage tank laws, supervised municipal industrial pretreatment programs, and conducted technical evaluations of land treatment of waste projects, ground water investigations, surface water modeling and monitoring programs and toxicity identification/evaluation studies.

1985-1986. Associate Engineer. Grice Engineering, Inc., Salinas, California.
Responsible for design projects and technical studies. Design projects included water supply (ground water wells) and distribution systems, grading and drainage plans and storm runoff

control facilities, onsite wastewater treatment systems and small agro-industrial wastewater treatment systems. Technical studies included ground water hydrology studies, soils investigations, and concrete floor and foundation studies.

PROFESSIONAL ASSOCIATIONS: American Water Works Association, American Society of Civil Engineers, Water Environment Federation, California Environmental Health Association

PUBLICATIONS/PRESENTATIONS

1. "Municipal Water Resource Planning and Management", Presentation at Seminar on Water Resource Protection and Management in San Pedro Sula, Cortes, Honduras, Central America, 9 December 1993 (presentation in Spanish)
2. Betancourt, D. and P.H. Haase, 1992, "Monitoreo Intensivo de los Puntos de Descargas de la Red de Alcantarillado Sanitario para la Ciudad de San Pedro Sula, Cortes, (Wastewater Characterization Study of all Discharges from the Municipal Sanitary Sewer of San Pedro Sula, Cortes), prepared for the Municipal Water Division of San Pedro Sula, Cortes, Honduras (DIMA) and the Interamerican Development Bank.
3. Haase, P.H., 1993, "Presentacion de las Normas de Control de Aguas Residuales Establecidas en Otros Paises y Costos de Tratamiento (Summary of Industrial Wastewater Control Standards in Different Countries and the Cost of Compliance by Several Types of Industries)", presented to DIMA and the Panamerican Health Organization (PAHO).
4. Haase, P.H. and M. Sagastume, 1993, "Control sobre Usos del Suelo para Proteger las Aguas Subterranas de San Pedro Sula, Cortes (Land Use Controls to protect Ground Water Resources in the Region of San Pedro Sula, Cortes), presented to DIMA, PAHO and the Honduran National Water Agency (SANAA).
5. "Towards Water Resource Management in San Pedro Sula, Cortes, Honduras", Technical Paper presented at the 1996 Annual Conference of the California/Nevada Section of the American Water Works Association, April 1996.
6. Batis, E., R. Rivera, G. Hill and P.Haase, 1996, "Computer Use for Laboratory Quality Assurance and Water Treatment Plant Operations", Technical Paper presented at the 1996 Annual Conference of Computer Use in Water Facility Operations, American Water Works Association, Austin, Texas.
7. Haase, P. H. and M. Sagastume, 1997, "A Model Program: Management and Protection of Ground Water Resources in San Pedro Sula, Cortes, Honduras", Technical Paper presented at Water Resources Management: Preparing for the 21st Century Conference, American Water Works Association, Seattle, Washington.
8. Buchanan, M., E. Corwin, P. Haase and M. Los Huertos, 2005, "Large Scale Sediment Source Identification and Load Estimation Designed to Inform the TMDL Process", Technical Paper presented at Watershed Management Conference, 2005. American Society of Civil Engineers, Williamsburg, Virginia

9. "Wastewater Treatment and Reuse with Natural Treatment Systems", 2006, Co-taught 40-hour course at the National University of Benito Juarez in Oaxaca, Oaxaca, Mexico
10. "Onsite Wastewater Treatment Wetlands Meet California's Nitrogen Reduction Requirements", 2006, California Onsite Wastewater Association News
11. "Guide for Rural Wastewater Management in China", Technical Guide prepared for World Bank China, 2011
12. Haase, P., A. Carter and T. Garrison, 2013, "High Rate Multi-Stage Recirculation Trickling Filters for Advanced Wastewater Treatment for Small Communities and Commercial Centers in Central California", 11th IWA Conference on Small Water and Wastewater Systems and Sludge Management, Harbin, China

EXHIBIT B



*Central
Coast
Watershed
Studies*

CCoWS



The Carr Lake Project: Potential Biophysical Benefits of Conversion to a Multiple-Use Park

Publication No. WI-2007-05
12 December 2007

Joel M. Casagrande¹
Fred Watson, PhD¹

The Watershed Institute
Division of Science & Environmental Policy
California State University Monterey Bay
<http://watershed.csumb.edu>

100 Campus Center, Seaside, CA, 93955-8001
831 582 4452 / 4431

¹Watershed Institute, California State University Monterey Bay
fred_watson@scsumb.edu

Created in 2005, the “1000 Friends of Carr Lake,” a group of community members and educators, are now working closely with local partners, such as the Watershed Institute, the City of Salinas, and the Big Sur Land Trust to make a multi-use park at Carr Lake a reality.

1.2 Objective and Report Structure

The objective of this document is to provide a summary of the current conditions in the Carr Lake Watershed and to discuss potential benefits to flood control, water quality, and habitat for wildlife if the lake is converted to a multi-use park.

This report contains a review of current hydrologic conditions, followed by a review of known water quality conditions and biological resources in the vicinity of the Carr Lake Watershed. The final chapter discusses the anticipated socio-economic and bio-physical benefits to converting Carr Lake into a multi-use regional park by drawing from relevant local studies and the literature.

1.3 Study Area

Carr Lake is a mainly privately owned, approximately 182-hectare (450 acre) historic lake bed that lies in the center of the City of Salinas in northern Monterey County (Fig. 1.1). The Lake, which has been drained and used as agricultural lands for much of the last century, captures runoff from approximately 260 km² (101 mi²) of the Gabilan Watershed and is a critical influence on flooding in the City of Salinas and downstream areas (SWCCE, 2002). Three creeks confluence in the Lake: Gabilan Creek to the north, Natividad Creek, and Alisal Creek to the south. The Lake is drained by the Reclamation Ditch, flowing northwest towards Castroville. Near Castroville the Reclamation Ditch becomes Tembladero Slough which flows into the Old Salinas River Channel before emptying into Moss Landing Harbor.

The Lake is an island of agricultural fields encircled by urban developments. Its upstream boundary is defined by East Laurel Ave and its downstream boundary is bordered by Highway 101. The lands between Highway 101 and East Laurel Ave as well as some developed areas, including the Sherwood Lake Mobile Home Park, are designated by FEMA as floodway (SWCCE, 2002). The floodway designation restricts future development plans in the Lake. In the updated 2002 General Plan, the City of Salinas designated Carr Lake as park space, rather than agricultural lands, suggesting a vision for Carr Lake as a park in the future.

Several parks and open space areas are in close proximity to the Lake (Fig 1.1). Just upstream is Upper Carr Lake, a remnant arm of the Lake restored in 2003. Further upstream is Natividad Creek Park, a partially restored multi-use park along Natividad Creek. To the northwest are the Salinas Rodeo Grounds and Sherwood Park and to the south Caesar E. Chavez Memorial Park.

1.4 Historical Conditions

Prior to large urban and agricultural developments much of the lower Gabilan Watershed was occupied by a large wetland complex, including a series of shallow lakes (Figs 1.2 & 1.3). Carr Lake, one of the larger water bodies, usually contained water year-round (SWCCE, 2002). The lakes and swamp areas were rich with wildlife some of which are now extirpated or extinct (Breschini et al. 2000; Gordon, 1996; Shumate, 1983).

After the turn of the 20th Century, agricultural developments expanded rapidly. The Reclamation Ditch was constructed between 1917 and 1920 for the purpose of draining the wetlands to be used for agriculture. The ditch was an enlargement of an existing waterway (Gabilan Creek) that connected the series of historic lakes (Fig 1.3). Carr Lake was first reclaimed by Jesse D. Carr in the early 1890's (Anderson, 2000; Breschini et al. 2000). Heavy rains during the winter of 1890 filled the lake causing it to spill into Salinas. This prompted Carr and others to modify the outlet of the lake and in doing so they were able to reclaim 1,475 acres. After the Reclamation Ditch was completed in 1920, Carr Lake and most of the other lakes were permanently reclaimed for agricultural uses. In the 1920's, Carr sold the lake and surrounding lands to a Japanese family who finished reclaiming the lands for farming. These lands are still farmed today by the descendants of this family which include the Ikedas, the Hibinos, and the Higashis (Cameron et al. 2003).

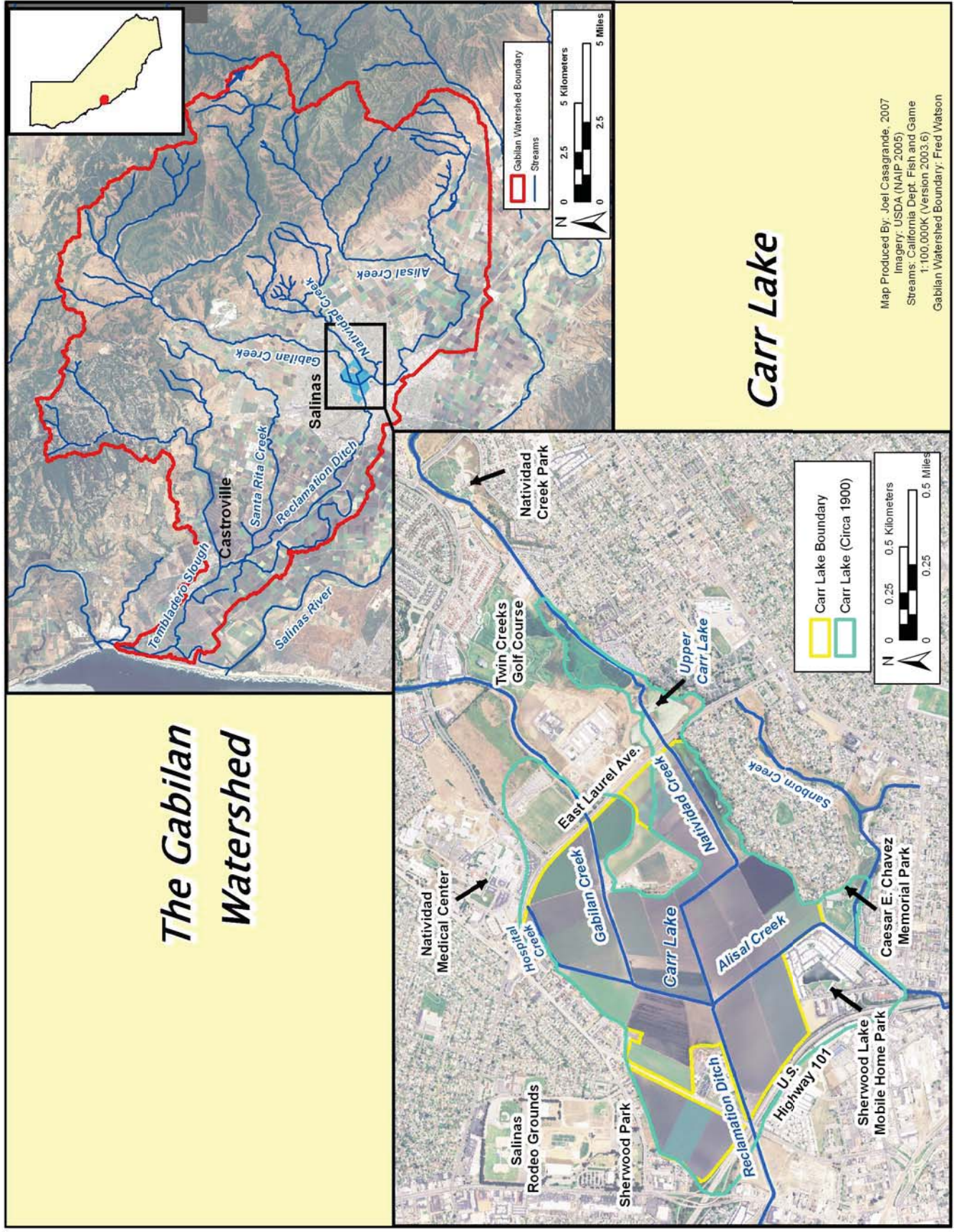

Figure 1.1 The Gabilan Watershed (upper right) and the Carr Lake basin and surrounding areas (lower left). Carr Lake boundary circa 1900 was estimated using the maps presented in Figures 1.2 and 1.3.

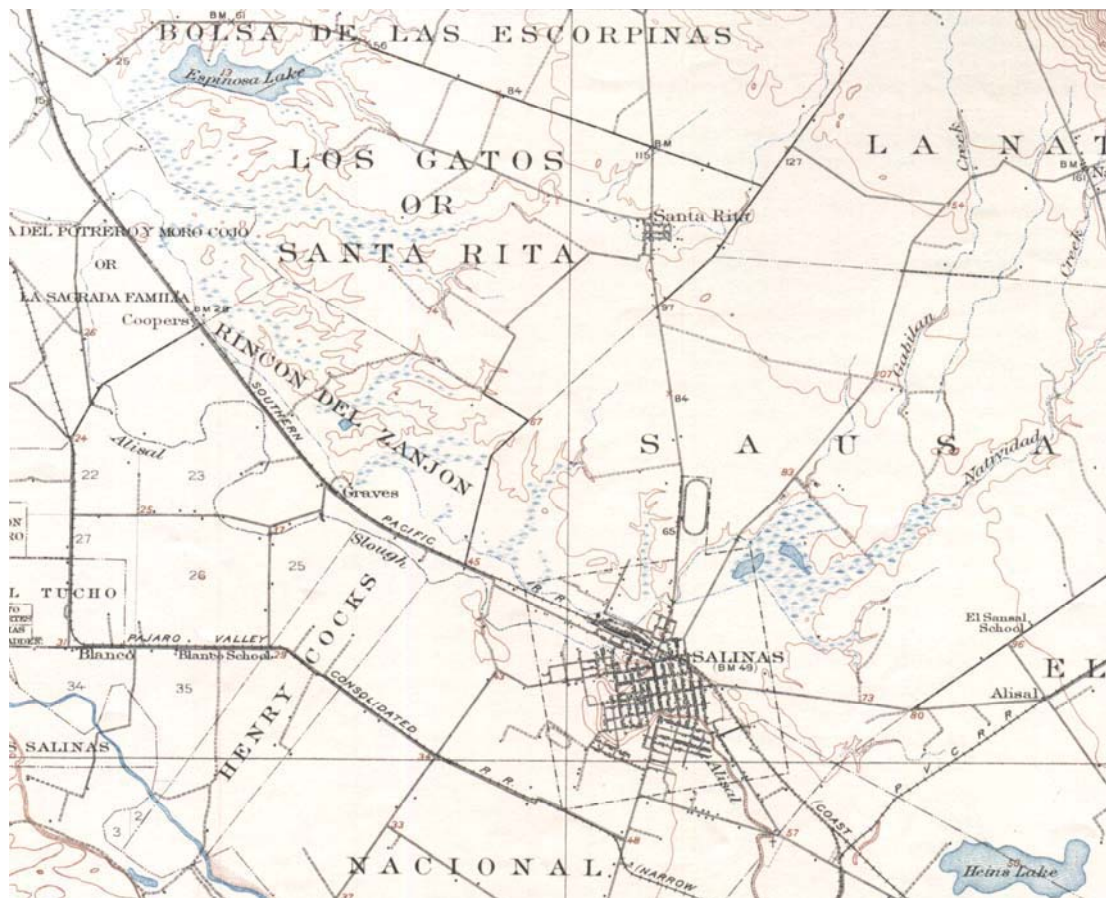

Figure 1.2 This 1912 USGS topo map of the Salinas vicinity (pre-Reclamation Ditch construction) shows some of the historic wetlands of the lower Gabilan Watershed including Espinosa Lake (upper left), Carr Lake (center right) and Heinz Lake (lower right corner).

1.5 Future Developments Upstream

In recent decades, lands upstream of Carr Lake along Gabilan and Natividad Creeks have experienced a large increase in suburban development. The City of Salinas's General Plan (2002) outlines locations for future growth (Fig 1.4). Most of the proposed development will occur north and east of the city limits (upstream of Carr Lake) on lands currently used for row crop agriculture (Fig 1.4). The new developments will be constructed in phases and will include a mixture of suburban residential and commercial uses (COS, 2002).

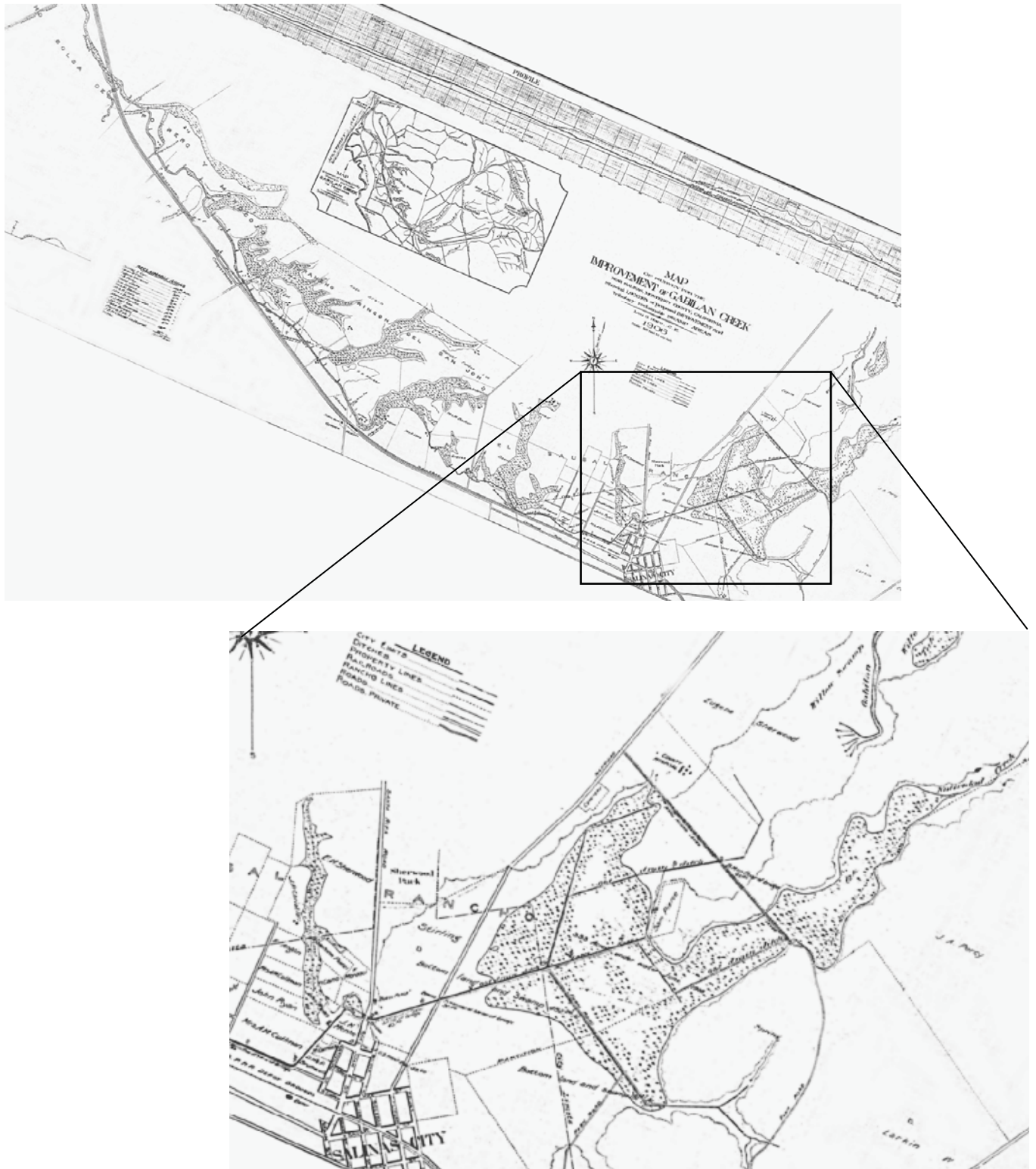

Figure 1.3 This reproduction of the original 1906 blue-print by Lou Hare, titled the “Improvement of Gabilan Creek”, is the initial design for the Reclamation Ditch and shows most of the historic chain of lakes (including Carr Lake in detail lower right).

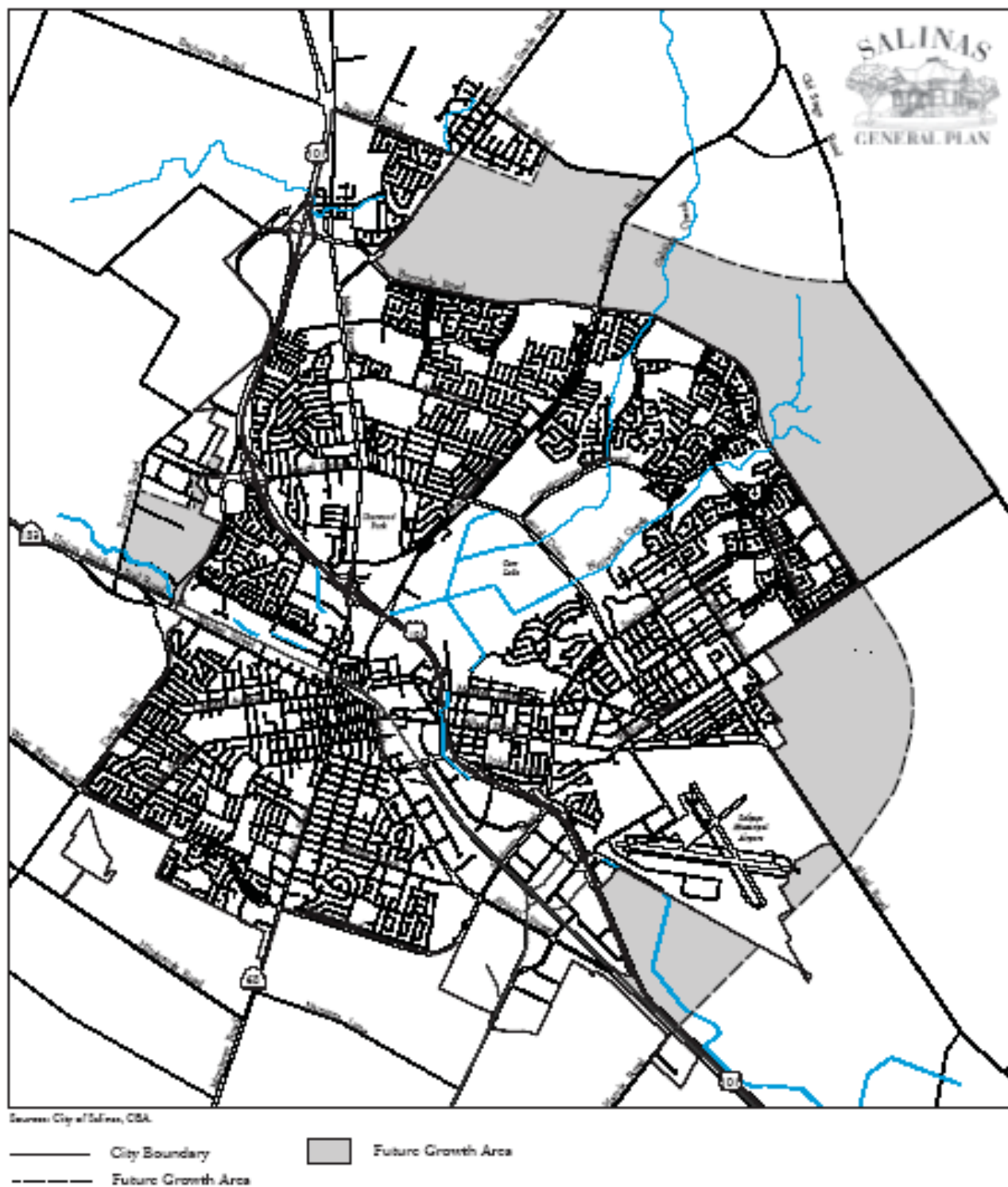

Figure 1.4 Future growth areas (gray shading) for the City of Salinas. Map reproduced from the City of Salinas General Plan (2002).

2 Hydrology

2.1 Watershed Overview

The Gabilan Watershed originates in the northern corner of the Gabilan Mountain Range northeast of the City of Salinas (Fig 1.1). There are three sub-watersheds that drain into Carr Lake, Gabilan to the north, Natividad Creek, and Alisal Creek to the south. Carr Lake is drained by the Reclamation Ditch which empties into Tembladero Slough just south of Castroville.

In their headwaters, Gabilan and Alisal Creeks maintain perennial flow down to the foothill region just east of Old Stage Road (Casagrande and Watson, 2006a). Lower Natividad and Alisal creeks usually have summer flow in most years due to agricultural runoff. Lower Gabilan Creek, just upstream of Carr Lake, maintains some flow during most conditions due to continuous groundwater pumping from beneath Alvarez High School.

Each of the major creek channels are key components to the flood control system. In the urbanized areas, runoff response is quick following moderate to heavy precipitation (USGS stream gage data online). Runoff is routed into the creeks through a network of storm drains and by agricultural ditches near the City's northern and eastern boundaries. Further upstream, in the agricultural and natural areas, runoff response to precipitation is slower (Casagrande and Watson, 2006a). Sediment loading into the creek channels is of concern to local agencies as it reduces channel capacities and increases maintenance costs for the City, County and local land owners (CDM, 2004; COS 2006a).

2.2 Carr Lake Hydrology

Carr Lake is a natural depression that captures runoff from 260 km² of watershed (Fig 1.1). The Lake functions as a thru-flow detention basin, where flows exiting the lake are controlled by the lake's water elevation. Drainage out of the lake is regulated by a double 8 ft x 8 ft box culvert under the Main Street bridge. The box culvert itself is undersized compared to others upstream and downstream of it and therefore restricts peak flows and downstream flooding (SWCCE, 2002). In addition, the culvert is usually impacted by accumulated sediments which require regular dredging (Casagrande and Watson, 2006a).

Beneath the box culvert is a 36-inch diameter pipe that is used to convey water during low flow periods. When stream flow is in excess of the pipe's capacity, water is impounded until it reaches the bottom of the overriding box culvert. This generally results in partial flooding of the lake during most storm events. Figure 2.1 shows the flood patterns and water elevations in the lake during a variety of runoff conditions. During a 2-year event, more than half of the lake bottom is flooded. This has been observed several times since 2000 (e.g. cover photo) and has been a common condition for some time (Bechtel Corp, 1959). During a ten year event, nearly

90% of the lake bed is inundated and in a 25 year event, the entire lake and some areas outside including the Sherwood Lake Mobile Home Park are inundated (Fig 2.1 C). At 100 year event, water elevations could spill onto Highway 101 and into parts of downtown Salinas (SWCCE, 2002; Cameron et al. 2003).

In summer, each of the channels in the lake has surface water due to upstream sources and local tile drains within the lake. The Lake's landowners install a seasonal earthen dam to restrict water from Gabilan Creek flowing up Natividad Creek (Cameron et al. 2003). A slide gate at the exit of Upper Carr Lake, east of East Laurel Ave. is used to regulate runoff from Natividad Creek into the lake bed.

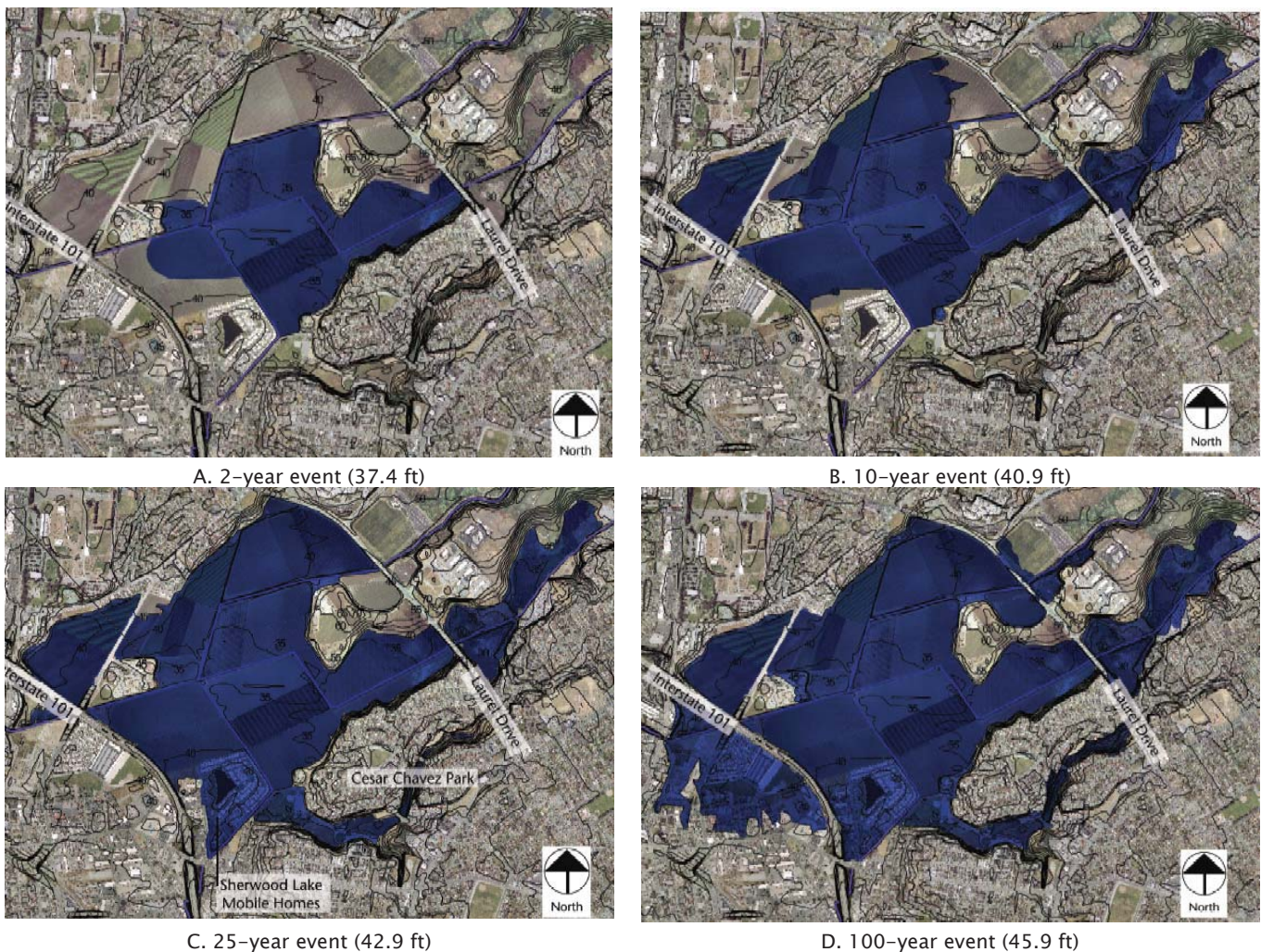

Figure 2.1 Estimated flood patterns in Carr Lake during a 2, 10, 25, and 100-year event. Water elevation values in parentheses. Images and elevation data reproduced from Cameron et al. 2003.

2.3 Recent Floods (1995 & 1998)

Since its construction in 1920, the Reclamation Ditch system has experienced significant flooding due to its limited capacity and the overall expansion of the urban areas upstream. During the winter of 1951/52, the Reclamation Ditch was unable to handle “record flows”, which resulted in significant flooding between the Alisal neighborhood and downtown Salinas (CDPHBSE, 1952).

The 1995 and 1998 El Nino events resulted in substantial flooding and property damage throughout the northern Salinas Valley, including Carr Lake and the Reclamation Ditch system. During this event, the City of Salinas received 20.1 inches of rainfall, approximately 6 inches above the annual average. Rainfall in the southern half of the Salinas Valley was more substantial (25.3 inches in King City) which caused the Salinas River to peak at 95,000 cfs at the Spreckels gage – the highest on record. The lower portions of the Gabilan Watershed were most impacted by floodwaters from the Salinas River which overtopped its banks at several locations sending river water onto the flat areas (Blanco Drain sub-watershed) between the

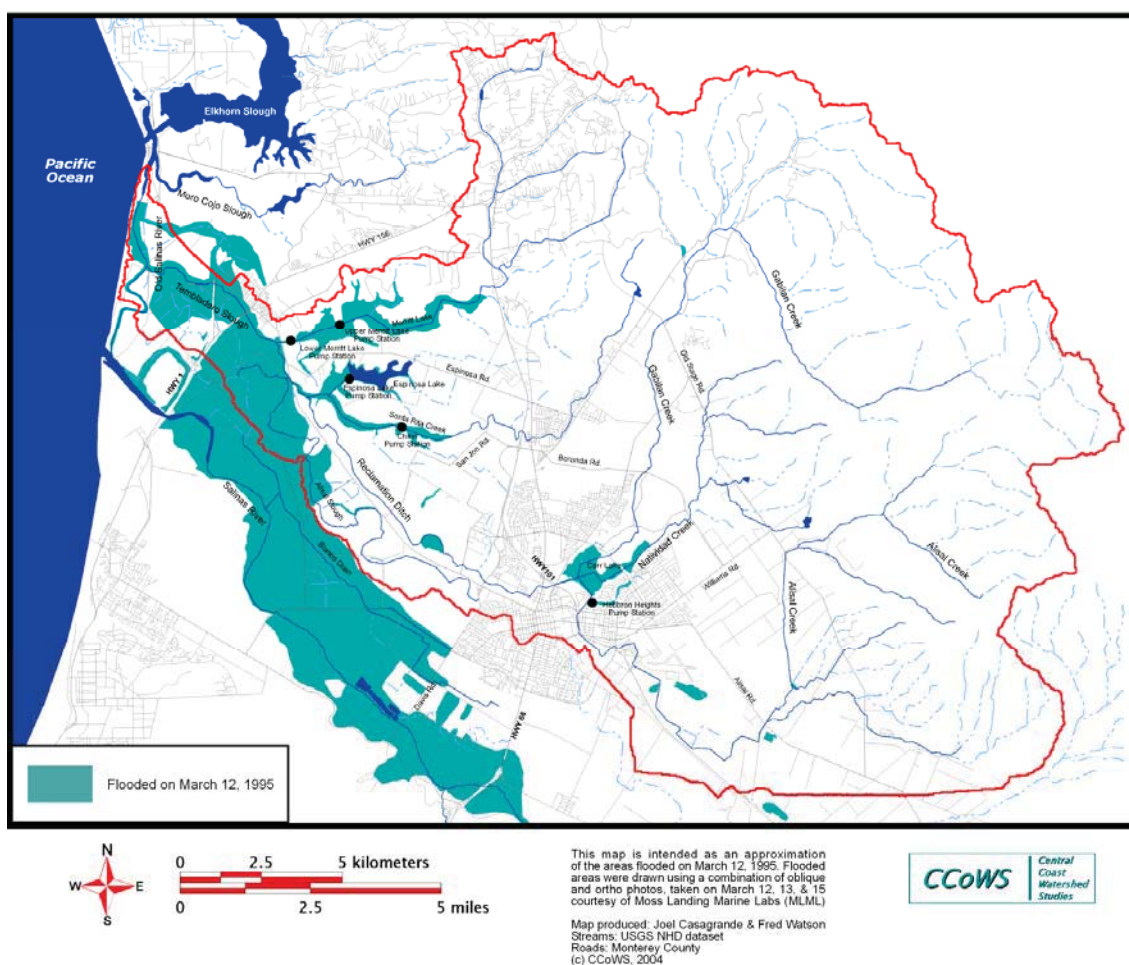

Figure 2.2 Flooded areas of the Northern Salinas River Valley and Reclamation Ditch Watershed at the peak of the flood on March 12, 1995. Reproduced from Casagrande and Watson, 2006a.

Reclamation Ditch and the Salinas River (Fig 2.2). This caused Tembladero Slough and the Reclamation Ditch (already at or near capacity) to backup, flooding both the Espinosa and the Merritt Lake drainages to the north. Further east, Carr and Heinz Lakes were partially filled due to heavy runoff from the Gabilan, Natividad and Alisal drainages (Fig 2.2).

During the winter of 1998, the city of Salinas received 30.1 inches of rain (second highest total on record). Gabilan Creek peaked at 1,035 cfs, a 25-year event and the highest level since records began in 1970. Carr Lake reached an elevation of 42.9 feet, flooding the Sherwood Lake Mobile Home Park for 11 days and reaching 0.1 feet from flooding a home situated on one of the raised “island” areas within the lake bed. While physical property damage was not significant, damage to fields and the drainage system itself were substantial.

2.4 Impacts to Carr Lake from Future Upstream Developments

Future developments upstream of the current City boundary (north of Boronda Rd and east of Williams Rd) are likely to increase runoff into the storm water system due to increases in the amount of impervious surfaces (Dunne and Leopold, 1978). The amount of additional runoff to the storm water system will ultimately depend on the extent of impervious surfaces, and whether or not management practices (e.g. detention basins, percolation basins) are constructed throughout the developments that will help reduce or slow down the amount of runoff entering the system (SWCCE, 2002; USEPA, 2004; Sayre et al. 2006).

SWCCE (2002) estimated that as of 2002, 4,372 acres of impermeable surface exists in the Carr Lake watershed. They predicted that a 66% increase in impervious surfaces (7,265 acres) would result in a 9% increase in peak flows entering Carr Lake during a 10-year event and 4% increase during a 100-year event. They also cautioned that these percentages could be greater during periods with frequent events (such as those witnessed in February 1998). SWCCE (2002) noted that the use of smaller detention basins and sediment catch-basins scattered throughout the developments could improve these percentages.

An indirect benefit of the future upstream land use conversion from predominantly row crop agriculture to suburban residential land will be reduced sediment sources from farm lands. While storm water runoff is likely to increase, sources of suspended sediment and bedload (sand and gravel) should be reduced from these lands (Charbonneau and Kondolf, 1993; Woodward and Foster, 1997).

The City of Salinas’s Storm Water Master Plan (CDM, 2004) notes that current sediment loading into the storm drain system from agricultural lands upstream of Boronda Road and Williams Rd presents a “major drainage problem” and that during high runoff events the “agricultural runoff also affects private properties”. SWCCE (2002) also remarks that efforts should be made to reduce sediment inputs from upstream sources prior to implementing any project in Carr Lake.

EXHIBIT C



Original Project Title:

**Carr Lake Watershed / Reclamation
Ditch Subwatershed Assessment and
Management Plan**

Prepared for MCWRA Board of Directors

Funded by The Federal EPA under the Clean
Water Act Section 205j Water Quality Planning
Program as,
SWRCB Grant No. 02-098-250-0 and by
Reclamation Ditch, Zone 9 Benefit
Assessment



The Watershed Institute

Division of Science and Environmental Policy
California State University Monterey Bay
watershed.csUMB.edu

100 Campus Center, Seaside, CA, 93955-8001
831 582 4452 / 4431.

*Central
Coast
Watershed
Studies*

CCoWS

Final Report:

**Monterey County Water
Resources Agency –
Reclamation Ditch
Watershed Assessment and
Management Strategy:**

Part A – Watershed Assessment

Acknowledgements

Report prepared by:

- Joel Casagrande (Watershed Institute, FCSUMB)
- Fred Watson, PhD (Project Leader, Watershed Institute, FCSUMB)
- In conjunction with MCWRA Project Manager and Technical Advisory Committee (listed below)

MCWRA Project Manager:

- Manuel Quezada (MCWRA Project Manager)

Technical Advisory Committee (TAC):

- George Fontes (Comgro Inc.)
- Ross Clark (California Coastal Commission, CCC)
- Amanda Bern (CCRWQCB)
- Bryan Largay (Resource Conservation District of Monterey County RCDMC)
- Traci Roberts (Monterey County Farm Bureau, MCFB)
- Carl Niizawa (City of Salinas)
- Kathleen Thomasberg (MCWRA)

Thanks to the following individuals and agencies. Note that the listing of their names here does not necessarily imply that this report reflects their opinions and/or interpretations.

- Mark Angelo (PE) and Karen Worcester (CCRWQCB)
- Laura Lee Lienk, Restoration Ecologist (CSUMB)
- Doug Smith Ph.D, RG, Geologist/Hydrologist, (CSUMB)
- CCoWS Technicians: Julie Hager, Don Kozlowski, Joy Larson, Wendi Newman
- CSUMB Students: Janna Hameister, Jessica Masek, Morgan Wilkinson
- MCWRA: Curtis Weeks, Richard Boyer, German Criollo, Rob Johnson
- City of Salinas: Denise Estrada, Chuck Lerable, Ron Cole
- Vasiliki Vassil (Soquel Creek Watershed Council and CSUMB)
- Jerry J. Smith Ph.D, Fisheries Biologist, (SJSU)
- John Oliver Ph.D, Wetland Ecologist (MLML)
- Gabilan Cattle Company: The Reeves Family, Darrell Boyle
- Emily Hanson & Melanie Bojanowski, Resource Conservation District of Monterey County (RCDMC)
- Don Roberson, co-author of *Atlas of Breeding Birds of Monterey County* (1993)
- David Suddjian, Local bird expert
- Brian Anderson, Department of Environmental Toxicology, University of California, Davis
- Chris Bunn, Crown Packing Co., Inc.
- Dennis Sites, Agricultural Consultant
- Eric Van Dyke (Geographical Ecologist, Elkhorn Slough National Estuarine Research Reserve)
- Michael Cahn, UC Cooperative Extension

Flooding

Historical records of significant flooding, specifically in the Carr Lake Watershed, are not well documented. . Photos documented by Breschini et al., (2000) show flooding on Lake Street⁷ in Salinas on March 11, 1911. This flood resulted after Carr Lake (a FEMA Floodway) filled and spread out onto the neighboring streets in the City of Salinas. More recently, during the winter of 1951/52, the Reclamation Ditch was unable to handle “record flows”, which resulted in flooding between the Alisal neighborhood and the City of Salinas (CDPHBSE, 1952).

In 1982/83, a significant storm hit the Central Coast of California. Anderson (2000) noted that 23.44 inches of rain fell on the City of Salinas that year and that the Blanco area along the Salinas River experienced the greatest damage. However, flooding was primarily water flowing slowly over an area causing less harm than faster, scouring flows.

⁷ Lake Street is located in the City of Salinas just downstream of Carr Lake.

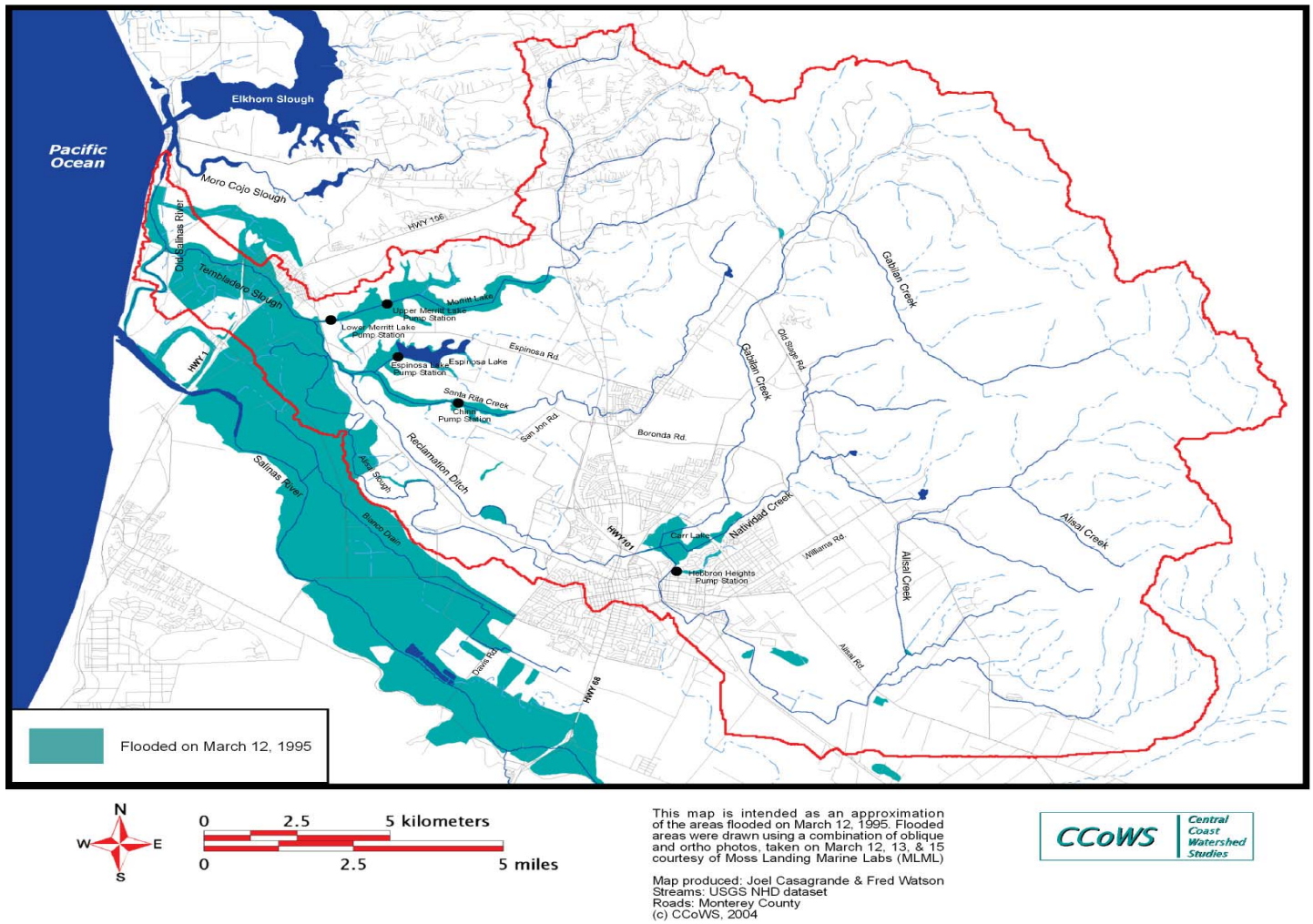

Figure 4.21 Flooded areas of the Northern Salinas River Valley and Reclamation Ditch Watershed at the peak of the flood on March 12, 1995. The flooded areas were interpreted from both oblique aerial photographs (taken March 12 and NASA ER-2, Color IR photos (taken March 15), and then drawn into GIS software.



Figure 4.22. Flooded areas during the March 1995 flood event, looking upstream at the Salinas River.



Figure 4.23. Flooded areas during the March 1995 flood event. Image B shows a nearly filled Carr Lake (upper-center). Images A, B, C illustrate the extent of the flooding in the northern Salinas Valley on March 12, 1995. Photos: John Oliver,



Figure 4.24 An example of the photos used for the evaluating flood extent on March 15, 1995. The photos are NASA ER-2, color infrared. Castroville is shown in the upper left corner and the Salinas River Lagoon in the lower left corner.

Tembladero and Moro Cojo Sloughs were unable to drain fast enough due to the addition of Salinas River water. Each of the pump stations, at Merritt and Espinosa Lakes and on the lower Santa Rita Creek drainage, were not able to discharge incoming runoff due to the additional water from the Salinas River. This led to substantial and prolonged inundation of these areas (Fig.). As a result, Castroville experienced significant flooding throughout much the town, including the entire intersection of HWY 156 and HWY 183.

Flooding was kept to a minimum within the City of Salinas and lands to the east and north of the city. Much of the flooding in this region of the watershed occurred in the historical lake bottom areas, although Carr and Heinz Lakes nearly filled.

During the winter of 1997/98, 30.09 inches of rain fell on the City of Salinas. This was the second highest annual rainfall total recorded since 1861/62. As a result, streamflow in Gabilan Creek reached 1,030 cfs, a 25-year event and the highest flow recorded since records began in 1970. Once again, local flooding occurred in the historical lake bottoms. Carr, Merritt, & Espinosa Lakes were filled with water backed up from the Reclamation Ditch as well as their own local runoff (SWCCE, 1999). Water elevations in Carr Lake reached an elevation of 42.9 ft, only 0.1 ft away from flooding structures

above the lake bottom (SWCCE, 1999). However, the Sherwood Lake Mobile Home Park, located in a FEMA Floodway along the southwest corner of the lake, was flooded for 11 days (SWCCE, 2002). For the Salinas River Valley, serious flooding of urban and agricultural lands was largely avoided because the events were smaller, occurred further north, and were less compounding.

Figure compares the hydrographs for Gabilan Creek at Hebert Rd during the 1995 and 1998 flood events. The hydrograph in 1995 shows a much lower peak daily mean flow than the 1998 hydrograph and thus flooding in Salinas and in the lands east and north of Carr Lake was less substantial than in 1998. Conversely, in 1998, rainfall and runoff totals were higher in the northern portion of the watershed and thus flood damage in the Carr Lake Basin was much more intense.

In summary, flooding remains an issue in the Reclamation Ditch Watershed. The continued increase in impervious surfaces has led to increased discharge and faster runoff response throughout the watershed has resulted in the increase in flood damage throughout the watershed. Most of the damage caused from flooding in average years occurs on farmlands, of which most lies within the historical lake bottoms and downstream of the City of Salinas.

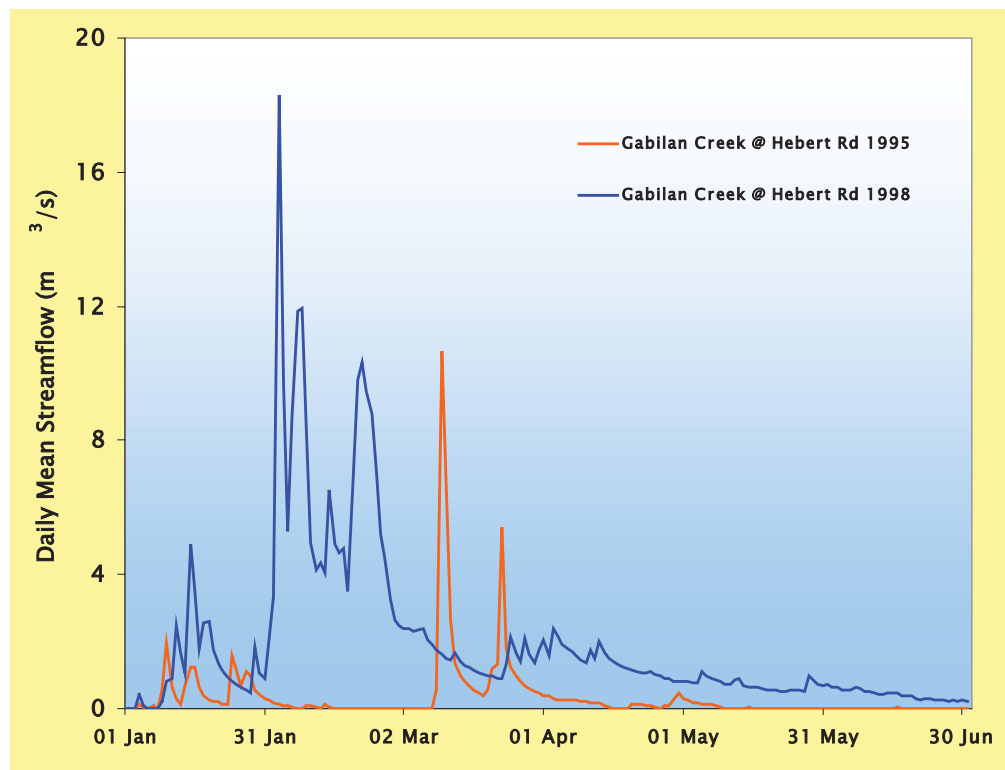

Figure 4.25 A comparison of Gabilan Creek stream flow during the 1995 and 1998 storm season. Stream flow data is from USGS.

Response to Letter 3 from Jason S. Retterer, L+G, LLP Attorneys at Law (August 27, 2014)

1. The commenter has included background information regarding flood control challenges on Carr Lake over time as Exhibit B and Exhibit C to the comment letter. It is acknowledged that commenter has provided documentation that identifies that increased impervious surfaces has resulted in the increase in flood damage throughout the watershed. The information included is known to the lead agency. The hydrology setting section of the EIR has been amended to include the expanded discussion provided by the commenter, which is incorporated by reference. This is an expansion of the existing setting discussion and does not change the conclusions in the Draft EIR. See Section 4.0 of this Final EIR for the text addition.
2. The commenter states that “the DEIR improperly fails to analyze certain impacts based on the conclusion of an initial study that analyzed a different project and fails to disclose, analyze and mitigate the Project's impacts on hydrology/drainage patterns. In addition, the DEIR's analyses of cumulative impacts and Project alternatives fail to meet the standards of CEQA. Thus, the DEIR does not fulfill its function as an informational and decision making document.” Specific comments regarding these issues are presented throughout the commenter’s letter and are addressed in the responses to comments numbered 3-22 below.

In summary, regarding the project description, the initial study evaluated both the potential impacts that may occur if only a portion of the project was developed (Phase I), and the potential impacts that may occur with full buildout of the project (as may occur with Phase II). Following distribution of the initial study, funding for Phase II (buildout of the project) was secured and the building design was further refined. The EIR evaluated construction of the project in a single phase. Therefore, the project description evaluated in the Draft EIR is substantially consistent with the project description evaluated in the initial study and the Draft EIR properly analyzed potential impacts identified in the initial study, and in accordance with CEQA, did not provide additional analysis of impacts that were determined to have “no impact.” Refer specifically to response to comments 4, 5 and 6 below.

The Draft EIR properly analyzed the project's impacts on hydrology/drainage patterns and determined impacts to be less than significant; therefore, no mitigation is necessary. Refer specifically to response to comments 8-20 below.

The Draft EIR complies with CEQA and the responses to comments provided in this Final EIR do not change the conclusions in the Draft EIR.

3. Comments identified in Exhibit A of the comment letter are responded to individually below (response to comments 17-22).
4. At the time the initial study was prepared, the County had only secured funding for construction of a 61,000 square-foot addition to the jail facility (referred to as Phase I in the initial study). However, funding for an additional 61,000 square feet of development for full buildout of the project (referred to as Phase II in the initial study) was reasonably foreseeable and was evaluated. The initial study evaluated both the potential impacts that may occur if only a portion of the project was developed (Phase I), and the potential impacts that may occur with full buildout of the project (as may occur with Phase II).

The initial study was based on conceptual project plans. The conceptual plans identified Phase I as 61,000 square feet of new construction consisting of either a) two 24-foot high, single-story buildings or b) one 48-foot high, two-story building (initial study page 8; Figure 3, Phase I Conceptual Design Option A; and Figure 4, Phase I Conceptual Design Option B) and Phase II as an additional 61,000 square feet of new construction consisting of either a) two 24-foot high, single-story buildings or b) one 48-foot high, two-story building (initial study page 8; Figure 5, Phase II Buildout Conceptual Design Option A; and Figure 4, Phase II Buildout Conceptual Design Option B).

Following distribution of the initial study, funding for Phase II (buildout of the project) was secured and the building design was further refined. The EIR therefore evaluated construction of the project in a single phase consisting of two adjacent buildings, a main 50-foot stacked structure with a second smaller, single-level building for administrative buildings. Total program area of the new buildings would be 134,370 gross square feet (gsf) with a building footprint of 57,000 gsf. The project evaluated in the EIR is consistent with the Phase II Option A option evaluated in the initial study but constructed in one phase with a slightly smaller footprint and a maximum height of 50, rather than 48 feet.

The project description evaluated in the Draft EIR is substantially consistent with the project description evaluated in the initial study.

5. As identified in the response to comment 4 above, the initial study evaluated four design options over two phases. This included an evaluation of the scale and massing of two 48-foot, two-story structures to house all 576 beds (Phase II Conceptual Design Conceptual Design Option B as described on page 8 and illustrated on Figure 6 of the initial study). The initial study determined that (at 48 feet high) the proposed buildings will not be taller than the tallest buildings currently within the complex (including the two- and three-story Natividad Medical Center) and that the existing jail facility cannot be seen from U.S. Highway 101, which is more than a mile away from the project site. Therefore, the proposed project would have no impact on a scenic vista and would not degrade the

existing visual character or quality of the site and its surroundings (initial study page 29). An additional two feet of building height would not change this conclusion. See also response to comment 4.

6. The initial study evaluated a maximum development scenario with a slightly larger footprint and massing and a two-foot lower building height than the refined design evaluated in the Draft EIR. In addition, the development evaluated in the initial study would be constructed over two phases rather than one. This project description is not fundamentally different than what was analyzed in the EIR.

CCR Section 15143 states “Effects dismissed in an Initial Study as clearly insignificant and unlikely to occur need not be discussed further in the EIR unless the Lead Agency subsequently receives information inconsistent with the finding in the Initial Study.” The County has not produced or received information inconsistent with the findings of the Initial Study. See also response to comment 4.

7. For clarification, the EIR has been amended to include the expanded discussion regarding the description of the environmental setting provided by the commenter. See Section 4.0 of this Final EIR for the text addition, which is included as an attachment to the comment letter and incorporated by reference. See also response to comment 1.
8. The hydrology analysis in the Draft EIR relies in part on a hydrology study prepared by BKF for the project entitled *Monterey County Jail Housing Addition Project - Hydrology Study* (BKF 2013) (hereinafter “2013 hydrology memo”), which is included as Appendix E of the Draft EIR. In response to concerns raised in this comment letter, the analysis presented in the 2013 hydrology memo was further refined in a subsequent *Monterey County Jail Housing Addition Project - Hydrology Study* memo (BKF 2015) (hereinafter “2015 hydrology memo”). The 2015 hydrology memo is included as [Appendix A](#) of this Final EIR.

References to the project being developed in two phases has been eliminated the 2015 hydrology memo to identify that the project will be built in a single phase. The discussion of existing drainage conditions has been expanded in the background section of the memo to identify that once the 48-inch diameter pipe exits the property, it crosses under East Laurel Drive and outfalls into Carr Lake, which in turn outfalls to the Reclamation Ditch that flows northwesterly to the Pacific Ocean (2015 hydrology memo page 1). The 2015 hydrology memo also provides greater distinction between “detention” versus “retention” facilities. The discussion of size, capacity, location and functioning of on-site and off-site drainage facilities has also been expanded with additional detail regarding drainage facilities.

In addition, a Conceptual Storm Water Control Plan (Kimley Horn 2015) has been prepared which further details the function of the existing drainage system. The Conceptual Storm Water Control Plan is included as [Appendix B](#) of this Final EIR.

For clarification, the EIR has been amended to include the expanded discussion and clarifications provided in both the 2015 hydrology memo, and Conceptual Storm Water Control Plan. See Section 4.0 of this Final EIR for the text addition. See also response to comment 7.

9. Regarding information on Carr Lake in the environmental setting section of the EIR, please refer to comment 1 and to comment 7.

The results of the analysis presented in the 2013 hydrology memo, which is included as Appendix E of the Draft EIR, indicated that with buildout of the project there would be a 0.3 cubic feet per second (cfs) increase in the peak flow rate for the 100-year storm event. As identified in the Draft EIR, the project will limit post-development runoff rates to be at pre-development runoff rates, consistent with the Regional Water Quality Control Board requirements. The 2015 hydrology memo, included as [Appendix A](#) of this Final EIR, determined that with the current design and footprint, the peak flow rate would increase by only 0.14 cfs from existing conditions, as opposed to 0.3 cfs in the 2013 report. In either case, as identified in both memos, the project will comply with applicable requirements to reduce peak flow to pre-developed rates for the two-year through 100-year rainfall events. The 2015 Conceptual Storm Water Control Plan prepared for the project demonstrates that all increases in flow are eliminated. Since the proposed project would result in no net increase in peak flow rate for the two-year through 100-year rainfall events, extensive discussion of the existing off-site storm drainage/flood setting, including the Carr Lake setting, was not deemed necessary. For clarification, the EIR has been amended to include the additional text, incorporated by reference, provided by the commenter. See also response to comment 1 and comment 7.

10. As identified in the Draft EIR, the proposed project must conform to post-construction requirements for hydromodification control and Low Impact Development requirements that have been established for projects under the jurisdiction of the Central Coast Regional Water Quality Control Board. The project will comply with the Post Construction Storm Water Management Requirements for Development Projects in the Central Coast Region, Resolution R3-2013-0032 (Post-Construction Requirements), adopted by the Central Coast Regional Water Quality Control Board on July 12, 2013 which defines post construction requirements for storm water management in Monterey County.

The Regional Water Quality Control Board requirements provide “at-the-source” solutions to the impacts of development on watersheds and encourage runoff from watersheds to mimic pre-development conditions. The Regional Water Quality Control

Board's Post Construction Requirements are intended, in part, to reduce changes in storm water peak flow runoff from new development relative to pre-project conditions in small storm events.

The proposed project will be required to provide a storm water management system that meets Regional Water Quality Control Board requirements including the specific post construction requirements identified in the County's Post Construction Requirements that the project be designed to include facilities that would reduce peak flow rates for the two-year through ten-year rainfall events to pre-developed rates and retain the runoff volume from the 95th percentile rainfall event.

As stated in the 2015 hydrology memo, included as [Appendix A](#) of this Final EIR, by providing sufficient retention storage on site for this purpose, the project would also have more than adequate storage volume for the runoff volume generated by the additional surface area for the 100-year event (pages 3 through 4).

A Conceptual Storm Water Control Plan (Kimley Horn 2015) included as Appendix B of this response to comments, has been prepared which further details the functioning of the proposed storm water management system. As identified in the Conceptual Storm Water Control Plan (pages 2 and 3), the Monterey County Jail Addition storm water management system is based upon the December 2013 Storm Water Development Standards for New Development and Redevelopment Projects ("Storm Water Development Standards") for the City of Salinas. These standards were selected in order to meet the concerns of the County and the surrounding community regarding runoff during storm events.

It was determined after evaluating the requirements set forth in the City's Storm Water Development Standards and the requirements of the County's Post Construction Requirements that the requirements of the City's Storm Water Development Standards is more conservative. The County standards require peak flow control through the 10-year rainfall event, whereas the City's Storm Water Development Standards require peak flow control through the 100-year rainfall event.

The results of the analysis included in the Conceptual Storm Water Control Plan shows that due to the project's drainage design, the post-project peak flow rate is less than the pre-project peak flow rate for the two-year through the 100-year storm events. Since the project is located in the Carr Lake watershed, peak flow rates from the 100-year, 72-hour storm event were also analyzed, and the results from this analysis show that the post-project peak flow rate is less than the pre-project peak flow rate for this storm event (pages 6 and 7). Due to the fact that infiltration is not possible on the site, the required detention volume will be detained and then metered off site through orifices that discharge flows at rates less than the pre-project peak flow rates.

Therefore, the project's drainage design will avoid increase in both peak flow rate and volume of runoff to not exceed existing conditions for the 100-year event thereby avoiding impacts on receiving waters, including Carr Lake.

11. The 2013 hydrology memo and the 2015 hydrology memos each identify bioretention areas as components of the conceptual storm water management system for the site. The 2015 hydrology memo, included as [Appendix A](#) of this Final EIR, specifically states that:

The geotechnical report states that "it is our opinion that on-site retention of collected storm drainage is not feasible given the low percolation rates of the insitu soil. (Butano 2013, pg 8)

The 2013 hydrology memo and the 2015 hydrology memos identify that because the existing soils have low percolation rates, runoff will be stored in bioretention facilities or a detention structure, such as a large diameter pipe. As stated in both memos, for either facility, existing two-year to 100-year peak flow rates and volumes will not be exceeded and the project is in compliance with all applicable regulatory standards for design to reduce peak flow to pre-project conditions. Therefore, as a result of the project meeting the requirements in the Regional Water Quality Control Board's Post Construction Requirements, the project will prevent offsite storm water discharges from events up to the 95th percentile rainfall event and limit the rate and volume of runoff discharge to not exceed existing conditions for the 100-year event. No increase in off-site storm water discharge is necessary and no change to downstream flood conditions, including those at Carr Lake, would occur.

The Conceptual Storm Water Control Plan prepared for the project (Kimley Horn 2015) also cites the 2013 Butano Geotechnical Engineering report's conclusion that no infiltration is possible on the site and states that the bioretention basins included in the project's storm water drainage design will address runoff reduction requirements and meet peak flow requirements (page 4).

As discussed in response to comment 10, and detailed in the Conceptual Storm Water Control Plan, in order to meet the concerns of the County and the surrounding community regarding runoff during storm events, the Monterey County Jail Addition storm water drainage design is based upon the City's Storm Water Development Standards, which are considered to be even more conservative than County standards. The storm water development standards require peak flow control through the 100-year rainfall event and require that low impact development principles and storm water Best Management Practices be included in the site design. Since the project is located in the Carr Lake watershed, peak flow rates from the 100-year, 72-hour storm event were also analyzed. The results from the analysis show that the post-project peak flow is less than the pre-project peak flow for the two-year through 100-year events and during the 100-year, 72-hour storm event (page 7).

The requirements of Monterey County, as defined within the Central Coast Regional Water Quality Control Board's Post-Construction Requirements (2013), have been incorporated into the project design in order to meet storm water water quality volumetric requirements for the project site (page 7). The Post Construction Requirements call for the prevention of offsite discharge from events up to the 95th percentile event and to retain this water onsite. These minimum required storage volumes will be retained onsite as a part of the onsite drainage system. This may be achieved via a variety of methods, which include an onsite storage and reuse system since infiltration is not possible within the project site.

As a result of the project meeting the County's Post-Construction Requirements and the City's Storm Water Development Standards, the project will prevent additional offsite storm water discharges and in fact will limit the rate and volume of runoff to be less than pre-project flow rate and volume. Therefore, even though the project will increase the impervious surface area of the site, resulting in an increase in storm water generated by the site, the project's installation of storm water control measures (bio-filtration/bio-retention facilities), results in a slight reduction of post-project peak flow rates and volumes (a reduction over existing conditions) which could be considered a beneficial impact to cumulative conditions.

The project's contribution to flood effects on Carr Lake would not be cumulatively considerable and less than cumulatively significant. Therefore, no changes to the conclusions in the Draft EIR are necessary.

12. The final overall project site plan/design will be required to incorporate storm water management measures and detention facilities to meet state and local requirements. As reported in the response to comment 7 and response to comment 10, the project is designed to meet the County's storm water management requirements and the City's Storm Water Development Standards such that peak-flow would not change relative to existing, pre-project conditions. As stated in the Conceptual Storm Water Control Plan (Kimley Horn 2015), the project's storm water management system design prevents offsite storm water discharges up to the 95th percentile rainfall event and limits the peak discharge rates and volumes of runoff to be less than pre-project peak discharge rates and volumes.

Since by design, and as required by existing regulations, the proposed project would reduce peak flow rates to pre-project rates for the two-year through 100-year events and during the 100-year, 72-hour storm event, mitigation measures are not required. The project storm water design elements are distinct and different from mitigation measures that are applied to a proposed project to mitigate residual impacts that are not avoided or substantially reduced by nature of the project design, or the regulations that are applicable. All projects

within the urbanized areas of Monterey County are subject to the same requirements to incorporate storm water management features into their project designs to meet the regulatory framework. In all cases, in all projects, as a result of the regulatory framework, these elements must be designed into the project or there is no project.

A Conceptual Storm Water Control Plan has been prepared and demonstrates that feasible design components are available to ensure that existing two-year through 100-year peak flow rates, as well as peak flow rates from the 100-year, 72-hour storm event are not exceeded. As identified in the Draft EIR, a final drainage plan will be subject to the review and approval by the County prior to the approval of any construction plans.

13. The Conceptual Storm Water Control Plan (Kimley Horn 2015) identifies site-specific drainage features that will be incorporated into the final design to ensure compliance with County storm water development standards. The intent of the Conceptual Storm Water Control Plan was to demonstrate that drainage facilities could feasibly be incorporated into the project that would meet the Regional Water Board's Post Construction Requirements and the City's Storm Water Development Standards such that post construction peak-flow rates and discharge volumes would not change relative to existing, pre-project conditions.

As identified in the 2015 Conceptual Storm Water Control Plan, the project will meet the County's Post-Construction Requirements and the City's Storm Water Development Standards, and limit the peak flow rate and runoff volume to no greater than existing conditions. The actual location and size of facilities may change with final configuration of the buildings. By providing sufficient retention storage and potential detention storage areas the project will be designed to avoid impacts due to increased peak flow rates on receiving waters, including Carr Lake. See also response to comment 11 above.

14. Fall Creek Engineering's specific comments regarding the Draft EIR's hydrology analysis are responded to below (response to comments 17-22).
15. See the response to comment 11 regarding cumulative impacts.

The *Final Supplement for the Salinas General Plan Final Program EIR* (City of Salinas 2007) concluded that, with implementation of detention/retention facility improvements and low impact development features as are proposed by development within the Future Growth Area, downstream impacts from increases in storm water flow rates or flow volumes would be less than significant (page 5.4-7).

As discussed in the response to comments 9, 10, 12 and 13, the proposed project will be required to include storm water control measures that meet the County's Post Construction Requirements that will ensure that the proposed project results in no discharge in small storm events up to the 95th percentile rainfall event. The project's

Conceptual Storm Water Control Plan also demonstrates that the standards of the City's 2013 Storm Water Development Standards for New Development and Redevelopment Projects, which are considered to be even more conservative than the County's standards will be met, resulting in no increase in peak flow rates relative to the existing, pre-project conditions. In addition, there will be no increase, in discharged storm water volumes relative to existing, pre-project conditions and therefore, no project-specific significant flood effects relative to existing, pre-project conditions. The proposed project's contribution to cumulative, off-site drainage impacts is also not significant and its effect is not cumulatively considerable. Therefore, no mitigation is required.

16. As described in the response to comment 11 the proposed project would not have a cumulatively considerable impact on flood conditions at Carr Lake. The proposed project would not be required to mitigate for existing deficiencies in hydraulic capacity of the Reclamation Ditch or other related flood control/drainage facilities located downstream of Carr Lake.

Exhibit A to the L+P LLC Comment Letter – Comments from Fall Creek Engineering

17. As identified in response to comment 8, the hydrology analysis in the Draft EIR relies in part on the 2013 hydrology memo prepared for the project, which is included as Appendix E of the Draft EIR. When the 2013 hydrology memo was prepared, the County had only secured funding for construction of a 61,000 square foot addition to the jail facility (Phase I). However, funding for an additional 61,000 square feet of development for full buildout of the project was reasonably foreseeable and was evaluated in the hydrology memo as "Phase II" buildout of the project. The conclusions and findings of the 2013 hydrology memo in regards to potential impacts associated with Phase II buildout of the project are consistent with the Draft EIR's evaluation of a single-phase project.

Regardless, in response to concerns raised in this comment letter, the 2013 hydrology memo was revised in a 2015 hydrology memo to specifically identify a single-phase project (included as [Appendix A](#) of this Final EIR). In addition, a Conceptual Storm Water Control Plan was developed based upon the December 2013 Storm Water Development Standards for New Development and Redevelopment Projects for the City of Salinas (included as Appendix B of this Final EIR). The information in the 2015 hydrology memo and in the Conceptual Storm Water Control Plan does not change the conclusions of the Draft EIR; therefore, no changes to the Draft EIR are necessary. Also see response to comment 4.

18. As discussed under response to comment 17, the hydrology analysis in the Draft EIR is based on the 2013 hydrology memo prepared for the project. Specifically, the Draft EIR relies on the findings in the memo associated with Phase II of the project (which is consistent with the buildout of the project).

Regardless, in response to concerns raised in this comment letter, the 2013 hydrology memo was revised in a 2015 hydrology memo to specifically identify a single-phase project. In addition, a Conceptual Storm Water Control Plan was developed based upon the December 2013 Storm Water Development Standards for New Development and Redevelopment Projects for the City (Kimley Horn 2015). The Conceptual Storm Water Control Plan demonstrated that the project’s design would meet the City’s storm water development standards such that peak-flow rate and volume would not change relative to existing, pre-project conditions. The information in the 2015 hydrology memo and the Conceptual Storm Water Control Plan does not change the conclusions of the Draft EIR; therefore, no changes to the Draft EIR are necessary. The 2015 hydrology memo and the Conceptual Storm Water Control Plan are included as Appendix A and B, respectively.

19. As identified in the 2015 hydrology memo, there would have been a very minor increase in impervious area that would result in an increase in the 100-year peak flow rate by only 0.14 cfs from existing conditions. The increase in flow rate would be limited so the existing two-year to 100-year flow rates are not exceeded. Please see [Appendix A](#) (2015 hydrology memo).

The Conceptual Storm Water Control Plan prepared for the project is based upon the December 2013 Storm Water Development Standards for New Development and Redevelopment Projects for the City (Kimley Horn 2015). The Conceptual Storm Water Control Plan demonstrated that the project’s design would meet the City’s storm water development standards such that peak-flow rates and discharge volumes would not change relative to existing, pre-project conditions. This additional information does not change the conclusions of the Draft EIR; therefore, no changes to the Draft EIR are necessary. See also response to comment 11.

20. The proposed project is required to ensure that post development flow rate does not exceed pre-development rates. If the pre-development two-year flow is causing erosion issues, it is an existing condition that is not caused by, or exacerbated by, the proposed project. Therefore, it is not the responsibility of the project to evaluate or mitigate potential erosion impacts on downstream facilities. No changes to the Draft EIR are necessary.
21. See the response to comment 11.
22. See response to comment 11.

This side intentionally left blank.

3.0

REVISED SUMMARY

3.1 CEQA REQUIREMENTS

CEQA Guidelines section 15123 requires that an EIR contain a brief summary of the proposed project and its consequences. The summary must identify each significant effect with proposed mitigation measures and alternatives that would reduce or avoid that effect; areas of controversy known to the lead agency; and issues to be resolved, including the choice among alternatives and whether or how to mitigate the significant effects. The Final EIR presents this revised summary as a concise overview of the EIR as revised through the public comment process.

3.2 TEXT OF REVISED SUMMARY

Beginning on the following page is a revised version of the summary from the Draft EIR. Additions to the text are shown with underlines and deletions are shown with ~~strikethroughs~~. Also refer to Section 4.0 Changes to the Draft EIR for other changes to the Draft EIR.

SUMMARY

CEQA REQUIREMENTS

CEQA Guidelines section 15123 requires an EIR to contain a brief summary of the proposed project and its consequences. The summary identifies each significant effect and the proposed mitigation measures and alternatives to reduce or avoid that effect; areas of controversy known to the lead agency; and issues to be resolved, including the choice among alternatives and whether or how to mitigate the significant effects.

PROJECT DESCRIPTION

This section contains a condensed description of the proposed project. For a detailed description of the proposed project, refer to Section 2.0 Project Description.

The proposed project will involve new building construction and expansion of the existing Monterey County Adult Detention Facility to accommodate 576 additional beds and associated program space for inmates housed in the detention facility. This project will increase the design (rated) bed capacity from 825 to 1,401 beds. As inmate populations fluctuate daily, the Sheriff's Department will continue to manage their inmate population at the design bed capacity of 1,401.

The proposed project will be constructed in one phase. The expansion will be constructed at the southwest corner of the existing detention facility property on a portion of the existing staff parking lot and a fenced grassy area and will consist of two adjacent buildings. The main building would be a 50-foot tall, stacked structure with housing units that have cells on the main floor and on a tier level. Additional program and support areas would be located on the main and second floors. A second smaller, single-level building located south west of the main structure will be designated for administrative purposes. The two buildings will be connected via a secured corridor to ~~an existing~~ sallyport within the existing jail.

SUMMARY OF IMPACTS AND MITIGATION MEASURES

This draft EIR identifies significant or potentially significant environmental impacts in several areas as identified below. The impacts are presented in a summarized format in [Table S-1](#). The full text of the environmental setting, project analysis, and impacts and the mitigation measures can be found in [Section 3.0, Environmental Setting, Impacts, and Mitigation Measures](#).

Significant Unavoidable Impacts

There are no significant and unavoidable impacts.

AREAS OF CONTROVERSY

CEQA Guidelines section 15123(b)(2) requires an EIR summary to identify areas of controversy known to the lead agency including issues raised by agencies and the public. Although the lead agency is not aware of any controversial issues, the following issues were raised by other agencies during the Notice of Preparation process. Letters are included in [Appendix A, Notice of Preparation and Responses](#). They are briefly summarized as follows:

- Potential impacts similar to other projects in the area such as the Salinas Regional Soccer Complex including but not limited to traffic, storm water, etc.;
- Hydrology and water quality (degradation from erosion or polluted runoff or increased flooding/plan preparation and filing requirements);
- Land use and planning (consistency with applicable land use plans/agency approvals);
- Energy conservation;
- Public services and utilities (consistency with master plans/review/approval/payment of fees);
- Traffic and transportation (expansion of traffic analysis to include additional intersections/payment of fees);
- Traffic and transportation (parking);
- Aesthetics (exterior design);
- Hazards (building code conformance), and
- Air Quality (construction emissions).

Table S-1 Significant Impacts and Mitigation Measure Summary

Area of Concern	Significant Impact	Mitigation Number	Mitigation Measure Summary	Residual Impact
Biology	Special-Status Species (Nesting Birds) (Potential Impact)	BIO-1	Avoidance measures and/or pre-construction surveys to ensure development activities will not disrupt nesting activities.	Less than significant
Cultural Resources	Damage to Buried Historical or Archaeological Resources (Potential Impact)	CR-1	Implementation of the County’s standard requirements for accidental discovery of cultural, archaeological, historical or paleontological resources.	Less than significant
Cultural Resources	Disturbance of Human Remains (Potential Impact)	CR-2	Implementation of the County’s requirements for accidental discovery of human remains.	Less than significant
Noise	Exposure of People to Excessive Groundborne Vibration (Construction Noise) (Potential Impact)	N-1	Restrictions in the project plans and specifications to mitigate construction vibration: limiting the hours of construction and use of sonic pile drivers (if the use of pile drivers are necessary).	Less than significant
Noise	Exposure of People to Substantial Temporary or Periodic Increases in Noise Levels (Construction Noise) (Potential Impact)	N-2	Restrictions in the project plans and specifications to mitigate construction noise: limiting the noise level of equipment, limiting the hours of construction, and ensuring that noise control devices (such as mufflers) and methods (such as buffering and equipment location) is used.	Less than significant

Area of Concern	Significant Impact	Mitigation Number	Mitigation Measure Summary	Residual Impact
Transportation/Traffic	Conflict with an Policy Establishing Measures of Effectiveness for the Performance of the Circulation System (Natividad Road/Laurel Drive intersection)	T-1	Payment of the City of Salinas Traffic Impact Fee to contribute toward the transportation improvements identified in the City of Salinas Traffic Fee Ordinance Program for the Natividad Road/Laurel Drive intersection.	Less than significant
Transportation/Traffic	Decrease the Performance or Safety of Pedestrian Facilities	T-2	Final development plans must include sidewalks, pathways or directional signage on the project site between the existing adult detention facility entrance and both Natividad Road and Constitution Boulevard.	Less than significant
Transportation/Traffic (Cumulative)	Cumulative (Natividad Road/Laurel Drive, Constitution Boulevard/Medical Center Driveway and Constitution Boulevard/North Driveway intersections)	Cumulative T-1	Payment of the City of Salinas Traffic Impact Fee to contribute towards the long-range transportation improvements identified in the City of Salinas Traffic Improvement Program, as well as a pro-rata share of the cost of signalization of the Constitution Boulevard/Medical Center Driveway intersection and the Constitution Boulevard/North Driveway intersection.	Less than significant

Source: EMC Planning Group Inc. 2014

This side intentionally left blank.

4.0

CHANGES TO THE DRAFT EIR

4.1 CEQA REQUIREMENTS

CEQA Guidelines section 15132 requires that a Final EIR contain either the draft EIR or a revision of the Draft EIR. This Final EIR incorporates the Draft EIR by reference and includes the revisions to the Draft EIR, as presented on the following pages.

4.2 CHANGES MADE

This section contains text, tables and graphics from the Draft EIR with changes indicated. Additions to the text are shown with underlines and deletions are shown with ~~striketroughs~~. Also refer to Section 3.0 Revised Summary for an updated EIR summary.

Text on page 2-12 of the Draft EIR is revised to identify that one, not two desks will be incorporated into each double occupancy cell.

Double occupancy cells will be provided for medium-security inmates. Stainless steel combination fixtures will be used. All cell doors will be hung doors constructed of steel. Two beds, one toilet, one washbasin and ~~two~~ one desks will be mounted.

Text on page 2-14 of the Draft EIR is revised to reflect current refinements to the project design including a small decrease in building footprint and re-orientation of the buildings on the project site.

Project Design

The proposed project will be constructed in one phase. The new construction was designed to provide modern housing facilities for 1,125 inmates currently housed in the existing detention facility, and provide housing for an additional 276 inmates. The expansion is to be constructed

at the southwest corner of the existing detention facility property and will consist of two adjacent buildings. The main building is a 50-foot tall, stacked structure with housing units that have cells on the main floor and on a tier level. Additional program and support areas are on the main and second floors. A second smaller, single-level building located ~~south~~ west of the main structure will be designated for administrative purposes. The two buildings will be connected via a secured corridor to ~~an existing~~ a sallyport within the existing jail.

The project will be located on a portion of the existing staff parking lot and a fenced grassy area. No existing structures are proposed for demolition. Total program area of the new buildings is 134,370 gsf. The building footprint is ~~57,000~~ 55,500 gsf. The proposed detention facility housing addition is shown as [Figure 4, Site Plan](#). An aerial view of the proposed building footprint is shown as [Figure 5, Site Plan – Aerial View](#).

Figure 4, Site Plan on page 2-15, and Figure 5, Site Plan – Aerial View on page 2-17 of the Draft EIR are revised to reflect current refinements to the project design including a small decrease in building footprint and re-orientation of the buildings on the project site as identified in the revised text above.

Text on page 2-20 Table 3, Contrast Pre-Conditions with Post-Project Conditions, last row is revised for clarification.

Lack of adequate unit control stations for housing areas.	Unit control stations will have direct visual supervision of all housing areas.
---	--

Text on page 3-8 of the Draft EIR is revised to capture text that was dropped due to a computer software error.

State and Federal Air Quality Standards for Criteria Pollutants. In general, criteria pollutants are pervasive constituents, such as those emitted in vast quantities by the combustion of fossil fuels. Both the State of California and the federal government have developed ambient air quality standards for the criteria pollutants, which include O₃, CO, NO₂, SO₂, and PM₁₀.

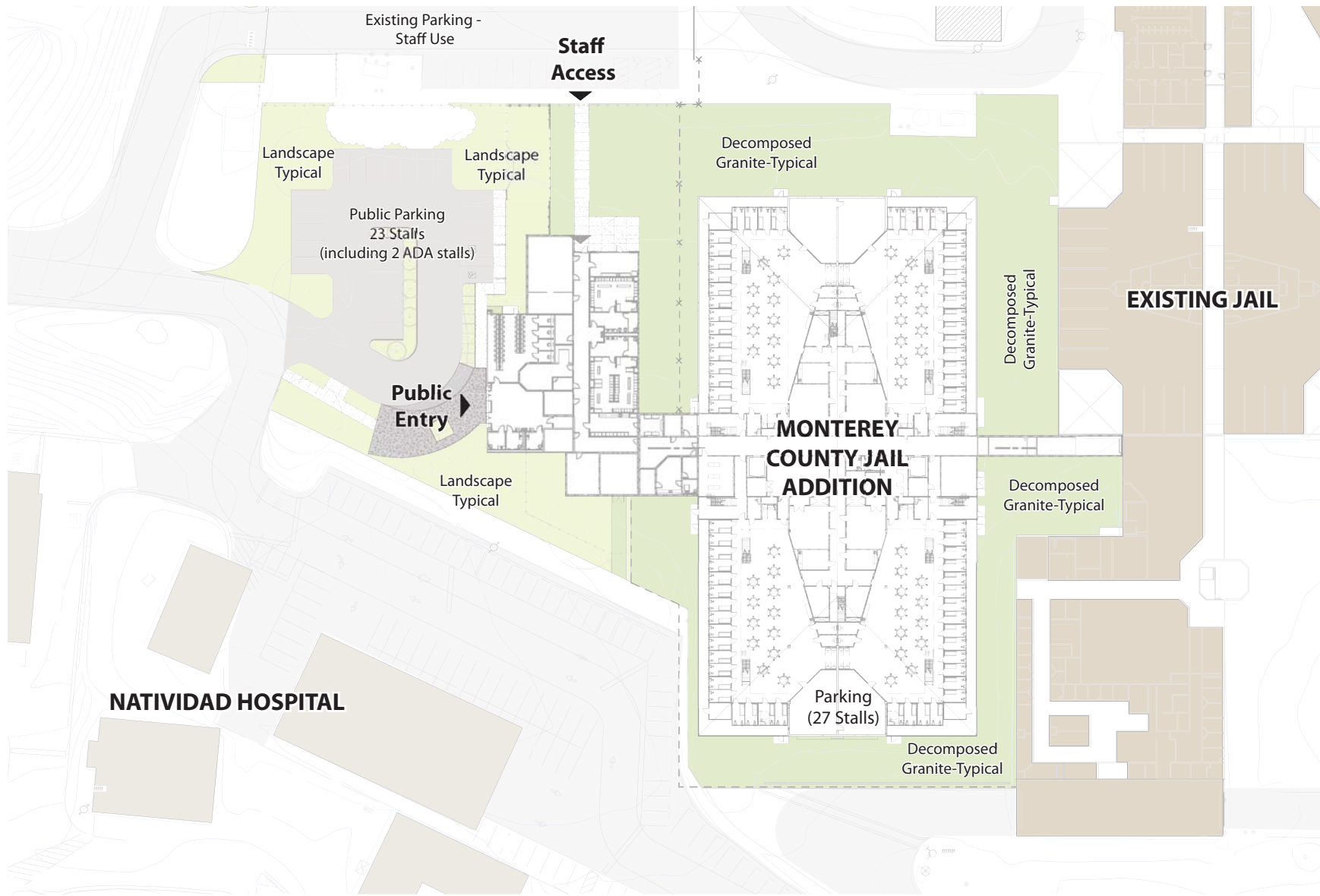

Source: Lionakis 2014

Figure 4
Site Plan



This side intentionally left blank.

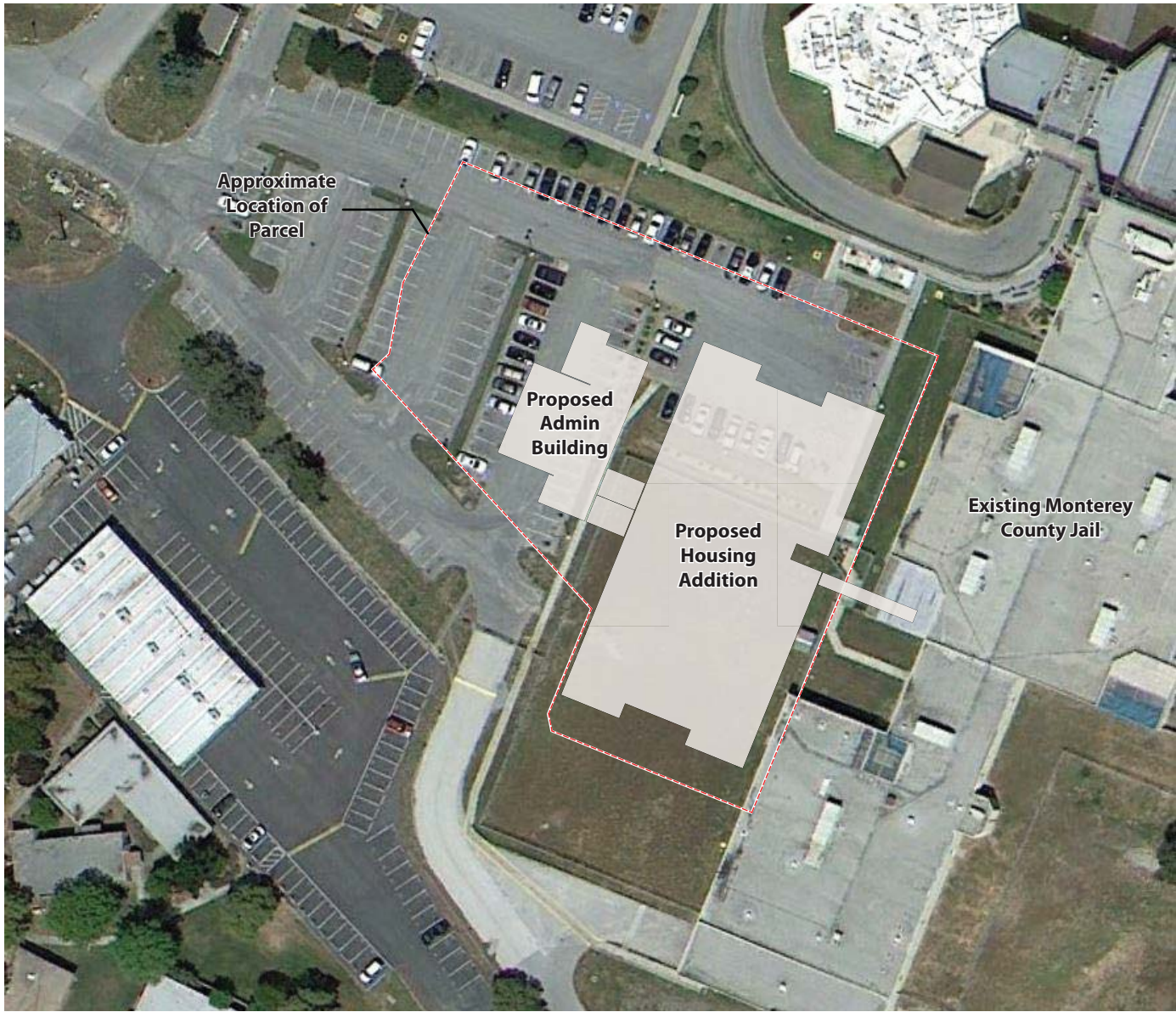

0 90 feet

--- Parcel Line (APN #003-851-034-000)

Source: Lionakis 2014, Google Earth 2012



Figure 5
Site Plan - Aerial View

Monterey County Jail Housing Addition EIR

This side intentionally left blank.

Text in Table 5 on page 3-9 of the Draft EIR is revised to capture text that was dropped due to a production error.

Table 5 Federal and State Ambient Air Quality Standards

Pollutant	Averaging Time	California Standards ¹		Federal Standards ²			
		Concentration ³		Primary ^{3,4}		Secondary ^{3,5}	
		ppm	µg/m ³	ppm	µg/ m ³	ppm	µg/ m ³
Ozone	1 Hour	0.09	180	-	-	-	-
	8 Hour	0.07	137	0.075	147	0.075	147
PM ₁₀	24 Hour	-	50	-	150	-	150
	Annual	-	20	-	-	-	-
PM _{2.5}	24 Hour	-	-	-	35	-	35
	Annual	-	12	-	15	-	15
Carbon Monoxide (CO)	1 Hour	20	23,000	35	40,000		
	8 Hour	9	10,000	9	10,000		
Nitrogen Dioxide (NO ₂)	1 Hour	0.18	339	0.100 ⁶	188	-	-
	Annual Mean	0.03	57	0.053	100	0.053	100
Sulfur Dioxide (SO ₂)	1 Hour	0.25	655	0.075	196	-	-
	3 Hour	-	-	-	-	0.5	1,300
	24 Hour	0.04	105	-	-	-	-
Lead ⁷	30 Day Average	-	1.5	-	-	-	-
	Rolling 3 Month	-	-	-	0.15	-	0.15
	Calendar Quarter	-	-	-	1.5	-	1.5
Visibility Reducing Particles	8 Hour	Extinction coefficient of 0.23 per kilometer -visibility of ten miles or more due to particles when relative humidity is less than 70 percent. Method: Beta attenuation and transmittance through filter tape.		No Federal Standards			
Sulfates	24 Hour	-	25				
Hydrogen Sulfide	1 Hour	0.03	42				
Vinyl Chloride ⁷	24 Hour	0.01	26				

Source: California Air Resources Board 2012

Notes:

1. California standards for ozone, carbon monoxide (except Lake Tahoe), sulfur dioxide (1 and 24 hour), nitrogen dioxide, suspended particulate matter—PM₁₀, PM_{2.5}, and visibility reducing particles, are values that are not to be exceeded. All others are not to be equaled or exceeded. California ambient air quality standards are listed in the Table of Standards in Section 70200 of Title 17 of the California Code of Regulations.
2. National standards (other than ozone, particulate matter, and those based on annual averages or annual arithmetic mean) are not to be exceeded more than once a year. The ozone standard is attained when the fourth highest eight hour concentration in a year, averaged over three years, is equal to or less than the standard. For PM₁₀, the 24 hour standard is attained when the expected number of days per calendar year with a 24-hour average concentration above 150 µg/m³ is equal to or less than one. For PM_{2.5}, the 24 hour standard is attained when 98 percent of the daily concentrations, averaged over three years, are equal to or less than the standard. Contact U.S. EPA for further clarification and current federal policies.

Text on page 3-15, Table 7 of the Draft EIR is revised to capture text that was dropped due to a computer software error.

Table 7 Unmitigated Operational Criteria Air Pollutant Emissions (Pounds per Day)

Pollutant Source	VOC	NO _x	SO ₂	CO
Total Emissions	5.31 lbs/day	2.52 lbs/day	0.02	10.51
<i>Air District Threshold</i>	<i>137 lbs/day</i>	<i>137 lbs/day</i>	<i>150 lbs/day</i>	<i>550 lbs/day</i>
Violation?	No	No	No	No

Text on page 3-16 of the Draft EIR is revised to capture text that was dropped due to a computer software error.

The project site is located adjacent to the existing County of Monterey Adult Detention facilities and Natividad Medical Center. The jail cells at the existing facility and hospital could be sensitive receptors, if jail inmates/hospital patients have access to outdoor areas, or access to operable windows. Operation of the project would not result in significant pollution emissions as discussed above; however, construction activities would result in emission of PM₁₀, and CO which can affect sensitive receptors.

Construction would result in emissions of PM₁₀, but these would not exceed standards (refer to previous impact discussion above). Maximum daily construction period CO emission levels would be about 95 pounds per day (Appendix B, Table 2.1 Overall Construction (Maximum Daily Emission)), far below the threshold of 550 pounds per day. The proposed project would be below thresholds for PM₁₀ and CO; therefore, the proposed project would not result in substantial pollutant concentrations that could impact sensitive receptors. The impact is less than significant.

Text on page 3-52 of the DEIR has been expanded to provide additional hydrologic setting information regarding off-site drainage flow and exiting conditions at Carr Lake, provided by L+G during the public comment period.

Drainage Conditions

The project area is within the Carr Lake watershed. In the area west of the existing adult detention facility, the site is mostly developed with buildings, roadways, and surface parking lots. The existing drainage patterns are influenced by the existing infrastructure, including but not limited to a series of gutters, catch basin inlets and storm drains. Runoff from the project site generally flows from the east to the west. Runoff is collected in a system of inlets and pipes that ultimately outfall to the grassy drainage swale to the west of the site. The grassy swale conveys flow to a 48-inch diameter pipe that flows south through the County property where it exits the property, crosses under East Laurel Drive and outfalls in to Carr Lake. Carr Lake outfalls to the Reclamation Ditch which flows northwesterly to the Pacific Ocean.

Carr Lake Watershed

As identified above, the project area is within the Carr Lake watershed. The following pertinent excerpts of *The Carr Lake Project: Potential Biophysical Benefits of Conversion to a Multiple-Use Park* (Joel M. Casagrande, Fred Watson, PhD, Central Coast Watershed Studies 2007) and page 84, related to Carr Lake flooding history from the *Final Report - Monterey County Water Resources Agency - Reclamation Ditch Watershed Assessment and Management Strategy: Part A Watershed Assessment* (Central Coast Watershed Studies 2001, page 84) were provided to describe the watershed and are incorporated by reference. They are Exhibit B and Exhibit C from Comment Letter 3.

Text on page 3-78 of the Draft EIR is revised to reflect the currently proposed parking areas (which were modified due to the refinements to the project design identified above).

The proposed project would not impact the parking spaces currently provided in Lots B and C. The ~~132~~ 5 spaces in these lots will be maintained, and designated as staff parking. However, the project would displace the parking provided in Lot A. The project will provide ~~40 new spaces; 27 spaces at the southeast corner of the new building and 13~~ 23 new spaces ~~on~~ to the west side of the new buildings. This will provide ~~152~~ 158 total parking spaces for the expanded facility, which will exceed the estimated parking demand for the project (146 spaces). See Figure 8, Proposed Parking.

The project will displace parking spaces used for Natividad Medical Center and County employee parking. The elimination of these spaces will be offset by using other areas identified for the Natividad Medical Center parking including but not limited to the area on the west side of the former hospital, which contains 84 parking spaces.

An adequate number of parking spaces will be provided for the project; therefore, the impact to parking would be less than significant.

Figure 8, Proposed Parking, on page 3-81 is revised to reflect the currently proposed parking areas (which were modified due to the refinements to the project design identified above).

Text on page 7-3 of the DEIR has been expanded to provide an additional source listing (for the additional text provided per these revisions to the EIR).

Cayan, Dan, Mary Tyree, and Sam Iacobellis (Scripps Institution of Oceanography, University of California, San Diego). *Climate Change Scenarios for the San Francisco Region. California Energy Commission*. Publication number: CEC-500-2012-042. 2012.

Central Coast Watershed Studies Final Report - Monterey County Water Resources Agency - Reclamation Ditch Watershed Assessment and Management Strategy: Part A Watershed Assessment. 2007.

City of Salinas. *City of Salinas General Plan*. September 2002.

Text on page 7-4 of the DEIR has been expanded to provide an additional source listing (for the additional text provided per these revisions to the EIR).

ICF Jones and Stokes. *2007 Monterey County General Plan Draft Environmental Impact Report*. September 2008.

Joel M. Casagrande, Fred Watson, PhD, Central Coast Watershed Studies. The Carr Lake Project: Potential Biophysical Benefits of Conversion to a Multiple-Use Park. 2007.

Monterey Bay Unified Air Pollution Control District. *Air District Attainment Status*. January 2013 (a).

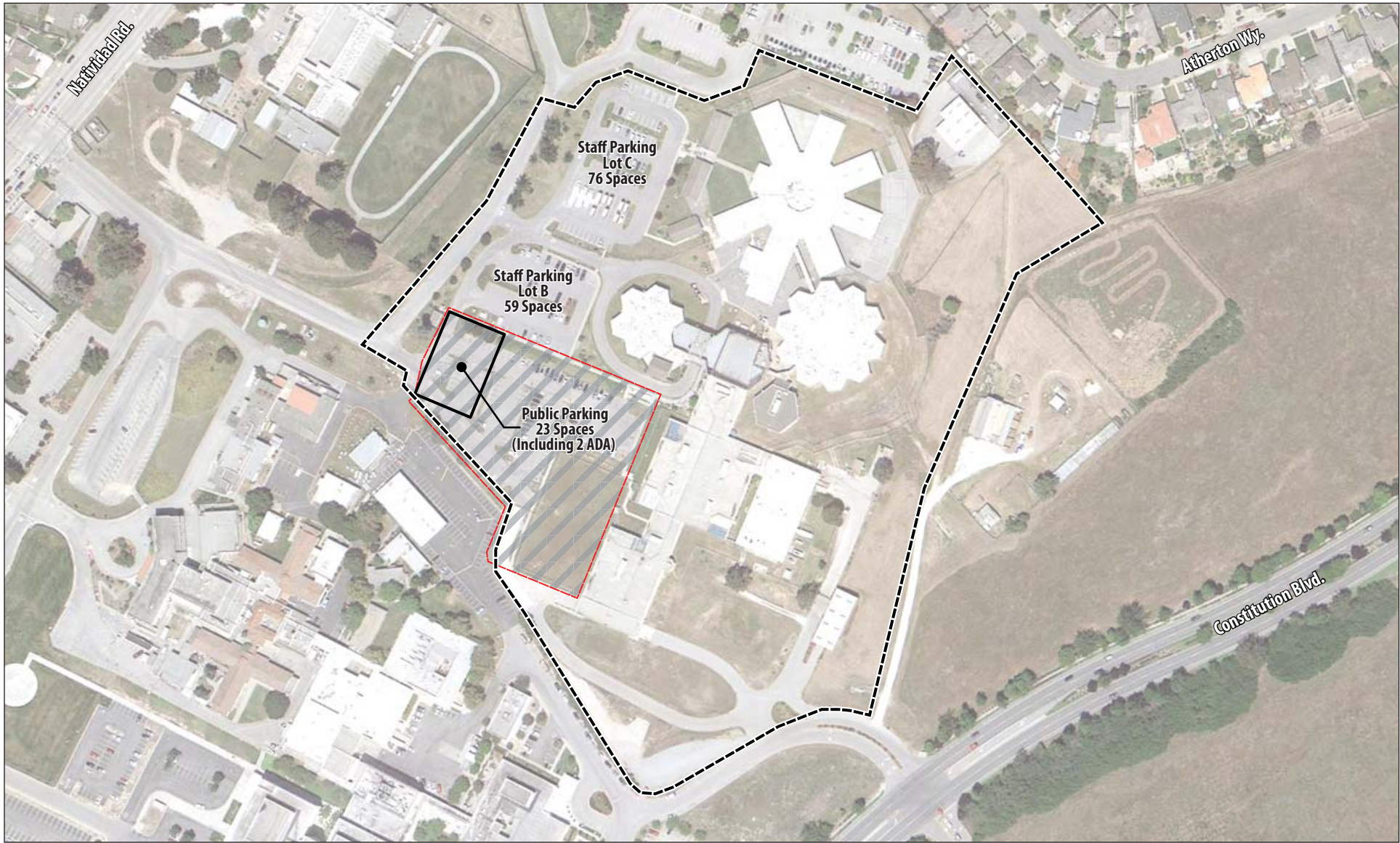

Source: Lionakis 2014, Google Earth 2012



Figure 8
Proposed Parking
 Monterey County Jail Housing Addition EIR

This side intentionally left blank.

5.0

MITIGATION MONITORING AND REPORTING PROGRAM

5.1 INTRODUCTION

CEQA Guidelines section 15097 requires public agencies to adopt reporting or monitoring programs when they approve projects subject to an environmental impact report or a negative declaration that includes mitigation measures to avoid significant adverse environmental effects. The reporting or monitoring program is to be designed to ensure compliance with conditions of project approval during project implementation in order to avoid significant adverse environmental effects. The law was passed in response to historic non-implementation of mitigation measures presented in environmental documents and subsequently adopted as conditions of project approval. In addition, monitoring ensures that mitigation measures are implemented and thereby provides a mechanism to evaluate the effectiveness of the mitigation measures.

5.2 MONITORING PROGRAM

The basis for this monitoring program is the mitigation measures included in the project Draft EIR. These mitigation measures are designed to eliminate or reduce significant adverse environmental effects to less-than-significant levels. These mitigation measures become conditions of project approval, which the County, acting as the project applicant and lead agency, is required to complete during and after implementation of the proposed project. This monitoring program is designed to provide a mechanism to ensure that mitigation measures and subsequent conditions of project approval are implemented.

Table 2, [Mitigation Monitoring Reporting Plan](#), presented on the following page, is proposed for monitoring the implementation of the mitigation measures. This monitoring program contains all mitigation measures in the Draft EIR.

5.3 MONITORING PROGRAM PROCEDURES

The County of Monterey is responsible for coordination of the monitoring program. The County of Monterey should be responsible for completing the monitoring program and distributing the monitoring program to the responsible individuals or agencies for their use in monitoring the mitigation measures.

Each listed responsible individual or agency is responsible for determining whether the mitigation measures contained in the monitoring program have been complied with. Once all mitigation measures have been complied with, the responsible individual or agency should submit a copy of the monitoring program with evidence of compliance to the County of Monterey to be placed in the project file. If the mitigation measure has not been complied with, the monitoring program should not be returned to the County of Monterey.

The County of Monterey will review the monitoring program to ensure that appropriate mitigation measures included in the monitoring program have been complied with at the appropriate time. Compliance with mitigation measures is required for project approvals.

If a responsible individual or agency determines that non-compliance has occurred, a written notice should be delivered by certified mail to the County of Monterey within 10 calendar days, describing the non-compliance and requiring compliance within a specified period of time. If non-compliance still exists at the expiration of the specified period of time, construction may be halted and fines may be imposed at the discretion of the County of Monterey.

Table 2 Mitigation Monitoring Reporting Program

Department: Monterey County RMA - Public Works Condition Compliance & Mitigation Monitoring and/or Reporting Program	Project Name: Monterey County Jail Housing Addition File No: _____ APNs: <u>APN #003-851-034-000</u> Approval by: <u>Monterey County Board of Supervisors</u> Date: _____
---	--

***Monitoring or Reporting refers to projects with an EIR or adopted Mitigated Negative Declaration per Section 21.081.6 of the Public Resources Code.**

Permit Cond. Number	Mitig. Number	Conditions of Approval and/or Mitigation Measures and Responsible Land Use Department	Compliance or Monitoring Actions to be performed. Where applicable, a certified professional is required for action to be accepted.	Responsible Party for Compliance	Timing	Verification of Compliance (name/date)
	MM #1	<p>(Biological Resources) If noise generation, ground disturbance, vegetation removal, or other construction activities begin during the nesting bird season (February 1 to September 15), or if construction activities are suspended for at least two weeks and recommence during the nesting bird season, the County will retain a qualified biologist to conduct a pre-construction survey for nesting birds. The survey will be performed within suitable nesting habitat areas on and adjacent to the site to ensure that no active nests would be disturbed during project implementation. This survey will be conducted no more than two weeks prior to the initiation of disturbance and/or construction activities. A report documenting survey results and plan for active bird nest avoidance (if needed) will be completed by the qualified biologist and</p>	<p>If grading activities begin outside of the nesting bird season, then no monitoring activities are necessary.</p> <p>If grading activities begin during the nesting bird season, then prior to the start of grading activities, Monterey County RMA - Public Works shall hire a qualified biologist to conduct a pre-construction survey for nesting birds.</p>	County of Monterey	Prior to site disturbance and/or construction	

5.0 MITIGATION MONITORING PROGRAM

Permit Cond. Number	Mitig. Number	Conditions of Approval and/or Mitigation Measures and Responsible Land Use Department	Compliance or Monitoring Actions to be performed. Where applicable, a certified professional is required for action to be accepted.	Responsible Party for Compliance	Timing	Verification of Compliance (name/date)
		<p>submitted to Monterey County RMA - Planning for review and approval prior to disturbance and/or construction activities.</p> <p>If no active bird nests are detected during the survey, then project activities can proceed as scheduled. However, if an active bird nest of a native species is detected during the survey, then a plan for active bird nest avoidance shall determine and clearly delineate an appropriately sized, temporary protective buffer area around each active nest, depending on the nesting bird species, existing site conditions, and type of proposed disturbance and/or construction activities. The protective buffer area around an active bird nest is typically 75-250 feet, determined at the discretion of the qualified biologist and in compliance with applicable project permits.</p> <p>To ensure that no inadvertent impacts to an active bird nest will occur, no disturbance and/or construction activities will occur within the protective buffer area(s) until the juvenile birds have fledged (left the nest), and there is no evidence of a second attempt at nesting, as determined by the qualified biologist.</p>				

Permit Cond. Number	Mitig. Number	Conditions of Approval and/or Mitigation Measures and Responsible Land Use Department	Compliance or Monitoring Actions to be performed. Where applicable, a certified professional is required for action to be accepted.	Responsible Party for Compliance	Timing	Verification of Compliance (name/date)
	MM #2	<p>(Cultural Resources) Due to the possibility that significant buried cultural resources might be found during construction, the following language shall be included as notes on all building and grading plans, subject to the review and approval of the Monterey County RMA - Planning Department:</p> <p>“If, during the course of construction, cultural, archaeological, historical or paleontological resources are uncovered at the site (surface or subsurface resources) work shall be halted immediately within 50 meters (165 feet) of the find until a qualified professional archaeologist can evaluate it. Monterey County RMA - Planning and a qualified archaeologist (i.e., an archaeologist registered with the Register of Professional Archaeologists) shall be immediately contacted by the responsible individual present on-site. When contacted, the project planner and the archaeologist shall immediately visit the site to determine the extent of the resources and to develop proper mitigation measures required for the discovery.”</p>	<p>If during the course of construction, cultural, archaeological, historical, or paleontological resources are uncovered on the site, immediately contact Monterey County RMA - Public Works and a qualified archaeologist/historian. The qualified archaeologist and/or historian shall determine the extent of the resources and develop the proper mitigation measures required for the discovery.</p> <p>Keep a certified daily log of each activity performed during construction including date and photographs, as necessary. Monthly reports shall be submitted to Monterey County RMA - Planning.</p>	County of Monterey	Anytime during earth-disturbing activities.	

5.0 MITIGATION MONITORING PROGRAM

Permit Cond. Number	Mitig. Number	Conditions of Approval and/or Mitigation Measures and Responsible Land Use Department	Compliance or Monitoring Actions to be performed. Where applicable, a certified professional is required for action to be accepted.	Responsible Party for Compliance	Timing	Verification of Compliance (name/date)
	MM #3	<p>(Cultural Resources) Due to the possibility of accidental discovery of human remains during construction, the following language shall be included as notes on all building and grading plans, subject to the review and approval of the Monterey County RMA - Planning Department:</p> <p>“If, during the course of construction, human remains are found, there will be no further excavation or disturbance of the site or any nearby area reasonably suspected to overlie adjacent human remains until the Monterey County Sheriff contacts the coroner of Monterey County to determine that no investigation of the cause of death is required. If the coroner determines the remains to be Native American, the coroner shall contact the Native American Heritage Commission within 24 hours. The Native American Heritage Commission shall identify the person or persons it believes to be the most likely descendent (MLD) from the deceased Native American. The MLD may then make recommendations to the landowner or the person responsible for the excavation work, for means of treating or disposing of, with appropriate dignity, the human remains and</p>	<p>If during the course of construction, human remains are found, stop activities until the Monterey County Sheriff contacts the coroner and determines cause of death. If the coroner determines the remains to be Native American, the coroner shall contact the Native American Heritage Commission within 24 hours.</p> <p>Keep a certified daily log of each activity performed during construction including date and photographs, as necessary. Monthly reports shall be submitted to Monterey County RMA - Planning.</p>	County of Monterey	Anytime during earth-disturbing activities.	

Permit Cond. Number	Mitig. Number	Conditions of Approval and/or Mitigation Measures and Responsible Land Use Department	Compliance or Monitoring Actions to be performed. Where applicable, a certified professional is required for action to be accepted.	Responsible Party for Compliance	Timing	Verification of Compliance (name/date)
		<p>associated grave goods as provided in Public Resources Code Section 5097.98. The landowner or his authorized representative shall rebury the Native American human remains and associated grave goods with appropriate dignity on the property in a location not subject to further disturbance if: a) the Native American Heritage Commission is unable to identify a MLD or the MLD failed to make a recommendation within 24 hours after being notified by the commission; b) the descendent identified fails to make a recommendation; or c) the landowner or his authorized representative rejects the recommendation of the descendent, and the mediation by the Native American Heritage Commission fails to provide measures acceptable to the landowner.”</p>				
	<p>MM #4</p>	<p>(Noise) Prior to issuance of a grading permit for the proposed project, Monterey County RMA - Public Works shall incorporate the following restrictions into the project plans and specifications to mitigate construction vibration, subject to the review and approval of Monterey County RMA - Planning:</p> <ul style="list-style-type: none"> ▪ Use of construction equipment or heavy truck traffic capable of producing 	<p>Include language on project plans as required by the mitigation measure.</p> <p>Submit evidence to the Monterey County RMA - Planning that the required restrictions have been incorporated into project plans and specifications</p>	<p>County of Monterey</p> <p>County of Monterey</p>	<p>Prior to issuance of grading or building permits</p> <p>Prior to construction</p>	

5.0 MITIGATION MONITORING PROGRAM

Permit Cond. Number	Mitig. Number	Conditions of Approval and/or Mitigation Measures and Responsible Land Use Department	Compliance or Monitoring Actions to be performed. Where applicable, a certified professional is required for action to be accepted.	Responsible Party for Compliance	Timing	Verification of Compliance (name/date)
		<p>excessive vibration (e.g. pile drivers, jackhammers, etc.) will be limited to the hours between 7:00 AM and 6:00 PM Monday through Saturday and construction will not be allowed Sundays or on holidays.</p> <ul style="list-style-type: none"> ▪ If the use of piles drivers is necessary, sonic pile drivers will be used rather than the more noise/vibration intensive impact pile drivers. 	<p>Keep a certified daily log of each activity performed during construction including date and photographs, as necessary. Monthly reports shall be submitted to Monterey County RMA - Planning.</p>	<p>County of Monterey</p>	<p>During grading and construction</p>	
	<p>MM #5</p>	<p>(Noise) Prior to issuance of a grading permit for the proposed project, Monterey County RMA - Public Works shall incorporate the following restrictions into the project plans and specifications to mitigate construction vibration, subject to the review and approval of Monterey County RMA - Planning:</p> <ul style="list-style-type: none"> ▪ All construction equipment operated on the project site shall be equipped to limit noise generation to a maximum of 85 decibels at a distance of 50 feet from the noise source. The contractor will prepare and submit a written roster of equipment anticipated to be used on the project site, including noise generation information on each for review and approval of Monterey County RMA - Planning. 	<p>Include language on project plans as required by the mitigation measure.</p>	<p>County of Monterey</p>	<p>Prior to issuance of grading or building permits</p>	
			<p>Submit evidence to the Monterey County RMA - Planning that the required restrictions have been incorporated into project plans and specifications.</p>	<p>County of Monterey</p>	<p>Prior to construction</p>	
			<p>Keep a certified daily log of each activity performed during construction including date and photographs, as necessary. Monthly reports shall be submitted to Monterey County RMA - Planning.</p>	<p>County of Monterey</p>	<p>During grading and construction</p>	

Permit Cond. Number	Mitig. Number	Conditions of Approval and/or Mitigation Measures and Responsible Land Use Department	Compliance or Monitoring Actions to be performed. Where applicable, a certified professional is required for action to be accepted.	Responsible Party for Compliance	Timing	Verification of Compliance (name/date)
		<p>Only those pieces of equipment meeting the standards of this mitigation measure shall be permitted to operate. If equipment not meeting the noise standards is found to be operating on the project site, work shall be stopped until that equipment is removed or made to meet noise standards;</p> <ul style="list-style-type: none"> ▪ All noise-generating construction activities shall be limited to the hours between 7:00 am and 6:00 pm Monday through Saturday and construction will not be allowed on Sundays or on holidays; ▪ All internal combustion engine-driven equipment will be equipped with mufflers that are in good condition and appropriate for the equipment; ▪ Temporary berms or noise barriers, such as lumber or other material stockpiles will be utilized, where feasible; and ▪ Stationary noise-generating equipment (e.g. generators and compressors) will be located as far as possible from sensitive receptors and housed in acoustical enclosures. 				

5.0 MITIGATION MONITORING PROGRAM

Permit Cond. Number	Mitig. Number	Conditions of Approval and/or Mitigation Measures and Responsible Land Use Department	Compliance or Monitoring Actions to be performed. Where applicable, a certified professional is required for action to be accepted.	Responsible Party for Compliance	Timing	Verification of Compliance (name/date)
	MM #6	(Transportation and Traffic) Prior to the commencement of construction activities, the County will pay the City of Salinas Traffic Impact Fee to contribute toward the transportation improvements identified in the City of Salinas Traffic Fee Ordinance Program for the Natividad Road/Laurel Drive intersection.	Pay the pro rata share City of Salinas traffic impact fee to City of Salinas, based on that project component’s share of build-out traffic, and the then-current cost estimates for improvements at the Natividad Road/Laurel Drive intersection as identified in the City of Salinas Traffic Fee Ordinance Program.	County of Monterey	Prior to construction	
	MM #7	(Transportation and Traffic) To ensure adequate pedestrian facilities are provided, final development plans will include sidewalks, pathways or directional signage on the project site between the existing adult detention facility entrance and both Natividad Road and Constitution Boulevard. Final plans are subject to the review and approval of Monterey County RMA - Planning and RMA - Public Works.	Prepare an off-site improvement plan for the listed improvements and submit the plans to Monterey County RMA – Planning for approval.	County of Monterey	Prior to approval of final development plans	
			Construct the improvements identified by this mitigation measure.	County of Monterey	Prior to occupancy	
	MM #8	(Cumulative Transportation and Traffic) The County will pay the Salinas Traffic Impact Fee to contribute towards the long-range transportation improvements identified in the City of Salinas Traffic Improvement Program, as well as a pro-rata share of the cost of signalization of the Constitution Boulevard/Medical Center Driveway	Pay the pro rata share long-range transportation improvements identified in the City of Salinas Traffic Improvement Program, as well as a pro-rata share of the cost of signalization of the Constitution Boulevard/Medical Center Driveway intersection and the Constitution Boulevard/North Driveway intersection to the City of Salinas.	County of Monterey	Prior to construction activities	

Permit Cond. Number	Mitig. Number	Conditions of Approval and/or Mitigation Measures and Responsible Land Use Department	Compliance or Monitoring Actions to be performed. Where applicable, a certified professional is required for action to be accepted.	Responsible Party for Compliance	Timing	Verification of Compliance (name/date)
		<p>intersection and the Constitution Boulevard/North Driveway intersection. The County will consult with the City regarding the pro-rata fee. These improvements are not included in the Salinas Traffic Impact Fee program and will be subject to a Memorandum of Understanding between the City and the County.</p> <p>The Salinas Traffic Impact Fee and the pro-rata share of the intersection improvements will be paid prior to the commencement of construction activities.</p>				

This side intentionally left blank.

APPENDIX A

2015 HYDROLOGY STUDY MEMO



MEMORANDUM

Date: March 3, 2015
From: Brian Scott, BKF Engineers
To: Art Lytle, County of Monterey
Subject: Monterey County Jail Housing Addition Project
Preliminary Hydrology Study

This purpose of this memo is to present a preliminary study of the existing hydrologic conditions around the proposed Monterey County Jail Housing Addition Project (Project) site and the possible changes in hydrology and water quality that could result from the Project.

1. BACKGROUND

The Project site is located in the town of Salinas within Monterey County. The existing jail is located at the County's Detention facility on Natividad Road, bounded by East Laurel Road to the south, Natividad Road to the west and Constitution Boulevard to the east. In the area west of the existing jail, the site is mostly developed with buildings, roadways, and surface parking lots. Runoff from the project site generally flows from the east to the west. Runoff is collected in a system of inlets and pipes that ultimately outfall to the grassy drainage swale to the west of the site. The grassy swale conveys flow to a 48-inch diameter pipe that flows south through the County property where it exits the property, crosses under East Laurel Drive and outfalls in to Carr Lake. Carr Lake outfalls to the Reclamation Ditch which flows northwesterly to the Pacific Ocean.

The City has prepared a storm water master plan report (City of Salinas Storm Water Master Plan, May 2004). BKF reviewed the report to see if there are any known capacity issues around the Project site. The site is located within the Carr Lake watershed. Carr Lake is a dry lakebed that captures runoff from approximately 64,000 acres of watershed. The lake functions as a detention storage facility for the watershed. Per Section 2.3 of the report: *"City staff provided input on existing drainage problems within the City. In general, the existing drainage system functions well, unless there are blockages due to pipe or catch basin obstructions"*.

In addition, BKF spoke with the City of Salinas engineering staff to discuss city utility system. City staff indicated the most current information regarding storm drain capacity issues is in the master plan report. The report does not indicate there are any system capacity issues around the project site. Section 5 of the master plan report provides a recommended Capital Improvement Program (CIP) for the City's drainage system, with a priority ranking of 1 to 5 for each project. Based on the report, there are no proposed CIP projects around the project site.

2. EXISTING CONDITIONS

The total area for the Project is approximately 113,000 sf (2.59 acres), which represents about 0.004% of the total drainage area to Carr Lake. Figure 1 shows the Project site located



within the County property. Figure 2 shows the existing pervious and impervious surfaces for the Project site. Peak storm drainage flows were calculated using the Rational Method. The following information has been used to calculate peak 10-year and 100-year storm drainage flows:

- C-factor for impervious surfaces = 0.90
- C-factor for pervious surfaces = 0.30
- $T_c = 10$ minutes
- The rainfall intensity for the project site was obtained using Caltrans WinIDF program. This program provides an intensity, duration and frequency curve in table format. The IDF curve is based on local rainfall data that is closest to the project’s longitude and latitude.

Existing Peak Flows

Return Period	Weighted C-Factor	Intensity (in/hr)	Area (ac)	Flow (cfs)
10-year	0.66	1.68	2.59	2.86
100-year	0.66	2.48	2.59	4.22

3. PROPOSED CONDITIONS

The Project includes the construction of a new housing building, administration wing, surface parking lot and adjacent sitework. Figure 3 shows the conceptual site plan and pervious and impervious areas for the Project.

Proposed Peak Flows

Return Period	Weighted C-Factor	Intensity (in/hr)	Area (ac)	Flow (cfs)
10-year	0.68	1.68	2.59	2.95
100-year	0.68	2.48	2.59	4.36

4. STORMWATER TREATMENT

Based on discussions between the County and the City of Salinas, it was determined the project will be required to comply with the County’s stormwater management requirements. The Central Coast Water Board adopted Order R3-2012-0032 which defines Post-Construction Requirements (PCRs) for stormwater management for Monterey County. The County prepared the “Stormwater Technical Guide for Low Impact Design” to ensure projects comply with the PCRs.

As described in the Technical Guide, since the project will replace and/or create more than 22,500 sf of impervious surface, it will need to comply with the Tier 4 requirements which are outlined below:

- Prevent offsite stormwater discharge from events up to the 95th percentile rainfall event using Stormwater Control Measures.
- Control peak flow rates to not exceed pre-project rates for the 2-year through 10-year events.

To prevent offsite discharge from events up to the 95th percentile event, the project will need



to direct runoff from roofs, pavement and other impervious surfaces to a stormwater control measure (SCM) that retains runoff on site. Per the Technical Guide, the simplified method to calculate the water quality volume (WQV) for each SCM is:

$$\text{WQV (cf)} = \text{DMA}^1 \text{ (sf)} \times \text{Runoff Factor} \times \text{Storm Depth (ft)}$$

Per the Central Coast Region 95th Percentile 24-Hour Rainfall Depth map, the storm depth for the site is approximately 1.15 inches (0.096 feet). Refer to the attached table for the approximate WQV for each DMA. Figure 4 shows conceptual locations and areas for the SCMs. Each SCM will have an overflow drain to convey runoff to the site drainage system when the storage volume is full.

During the design process, the project will need to make a final determination with the County whether or not on-site retention is actually feasible for the project. The geotechnical report states that *“it is our opinion that on-site retention of collected storm drainage is not feasible given the low percolation rates of the in-situ soil.”* (Butano 2013, pg 8)

Per page 3-8 of the Technical Guide, there are two Alternative Compliance Options for projects that are not able to comply with on-site retention. The “Ten Percent Adjustment” option allows the use of other SCMs provided the area of the SCMs is equal to or greater than 10% of Equivalent Impervious Surface Area of the site. The second option allows an off-site mitigation project, which is not likely for the Project.

Because the existing soils have low percolation rates, the project is likely to request compliance with the “Ten Percent Adjustment” approach by providing bioretention facilities that are 10% of the equivalent impervious surface area of the Project site. The approximate size of the bioretention areas are at a minimum 4% of the impervious drainage area flowing to the bioretention area. The bioretention areas are located near the buildings and parking lots so runoff can easily be directed to them. A typical bioretention area consists of 18-inches of highly permeable soil over a minimum of 12-inches of drain rock. For each bioretention area, an overflow inlet is installed about 6-inches above the soil to allow runoff to pond and infiltrate prior to entering the inlet. The bioretention areas are sized so the WQV is stored within the soil and rock layers. Each layer is assumed to have a void ratio of 0.40.

5. FLOOD CONTROL

Controlling the peak rate of runoff is accomplished by storing runoff and discharging it at specific rate. For the Project, runoff will either be stored in bioretention facilities or in a detention structure, such as a large diameter pipe. For either facility, the storage volume must be calculated based on the pre- and post-construction peak flow rates. Runoff discharge is typically controlled by a small diameter pipe, or orifice opening, with a cross sectional area calculated such that the discharge rate does not exceed the pre-construction rate.

The water quality volume per the PCRs is approximately 6,777 CF (refer to the calculations), treating runoff from all newly created and replaced impervious areas (70,713 sf). The actual increase in impervious surface area created by the project is approximately 4,088 sf. Per



**ENGINEERS
SURVEYORS
PLANNERS**

NOAA Atlas 14, the 100-year rainfall depth is approximately 4-inches. The runoff volume generated by the additional impervious surface area for the 100-year event is 1,363 CF. This increase in the volume of runoff is far less than the storage volume required by the PCRs. Therefore the project will mitigate the small increase in rate and volume of runoff to not exceed existing conditions for the 100-year event.

6. CONCLUSION

The 2.59 acre Project site, located within the 64,000 acre Carr Lake drainage basin, represents only 0.004% of the total drainage basin. Based on the conceptual site plan, there would be a very minor increase in impervious area that would result in an increase the 100-year peak flow rate by only 0.14 cfs from existing conditions. As a result of the project meeting the requirements in the County's PCRs, the Project will prevent offsite stormwater discharge from events up to the 95th percentile rainfall event and limit the rate and volume of runoff to not exceed existing conditions for the 100-year event.

K:\MAIN\2008\080121\06 Design\C Storm Drain System\20150303 Storm Drainage Memo.doc

**MONTEREY COUNTY JAIL ADDITION
 PRELIMINARY HYDROLOGY CALCULATIONS**

C-Factors

C (pervious)	0.30
C (impervious)	0.90

WEIGHTED C-FACTORS

	Pervious (sf)	Impervious (sf)	Total Area (sf)	Weighted C-Factor
Existing	45,851	67,149	113,000	0.66
Proposed	41,763	71,237	113,000	0.68

EXISTING PEAK FLOW RATES

Return Period	C-Factor	Intensity (in/hr)	Area (ac)	Flow (cfs)
10-year	0.66	1.68	2.59	2.86
100-year	0.66	2.48	2.59	4.22

PROPOSED PEAK FLOW RATES

Return Period	C-Factor	Intensity (in/hr)	Area (ac)	Flow (cfs)
10-year	0.68	1.68	2.59	2.95
100-year	0.68	2.48	2.59	4.36

WATER QUALITY VOLUME (WQV)

	Inches	Feet
95th % Rainfall Depth	1.15	0.096

DMA	Area (sf)	C-Factor	Rainfall Depth (ft)	WQV (cf)
1	21,706	1.00	0.096	2,080
2	21,706	1.00	0.096	2,080
3	11,973	1.00	0.096	1,147
4	15,328	1.00	0.096	1,469
	70,713			6,777

Per the Technical Guide, a runoff factor of 1.0 is used for impervious surfaces for small storm events

STORMWATER CONTROL MEASURE SIZING (SCM) - BIORETENTION AREAS

DMA	Required Volume (cf)	Surface Area (sf)	Soil Layer Storage Volume (cf)	Stone Layer Depth (in)	Soil Layer Storage Volume (cf)	Soil + Stone Volume (cf)
1	2,080	2,000	1,200	13.2	880	2,080
2	2,080	2,000	1,200	13.2	880	2,080
3	1,147	1,654	992	12.0	662	1,654
4	1,469	1,531	919	12.0	612	1,531
	6,777					7,345

Per the Technical Guide, the soil and stone layers are assumed to have a porosity of 0.40.

The minimum depth of the soil layer is 18".

The minimum stone layer depth is 12". The stone layer depth is adjusted to achieve the required WQV.

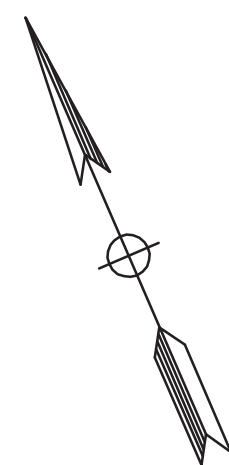
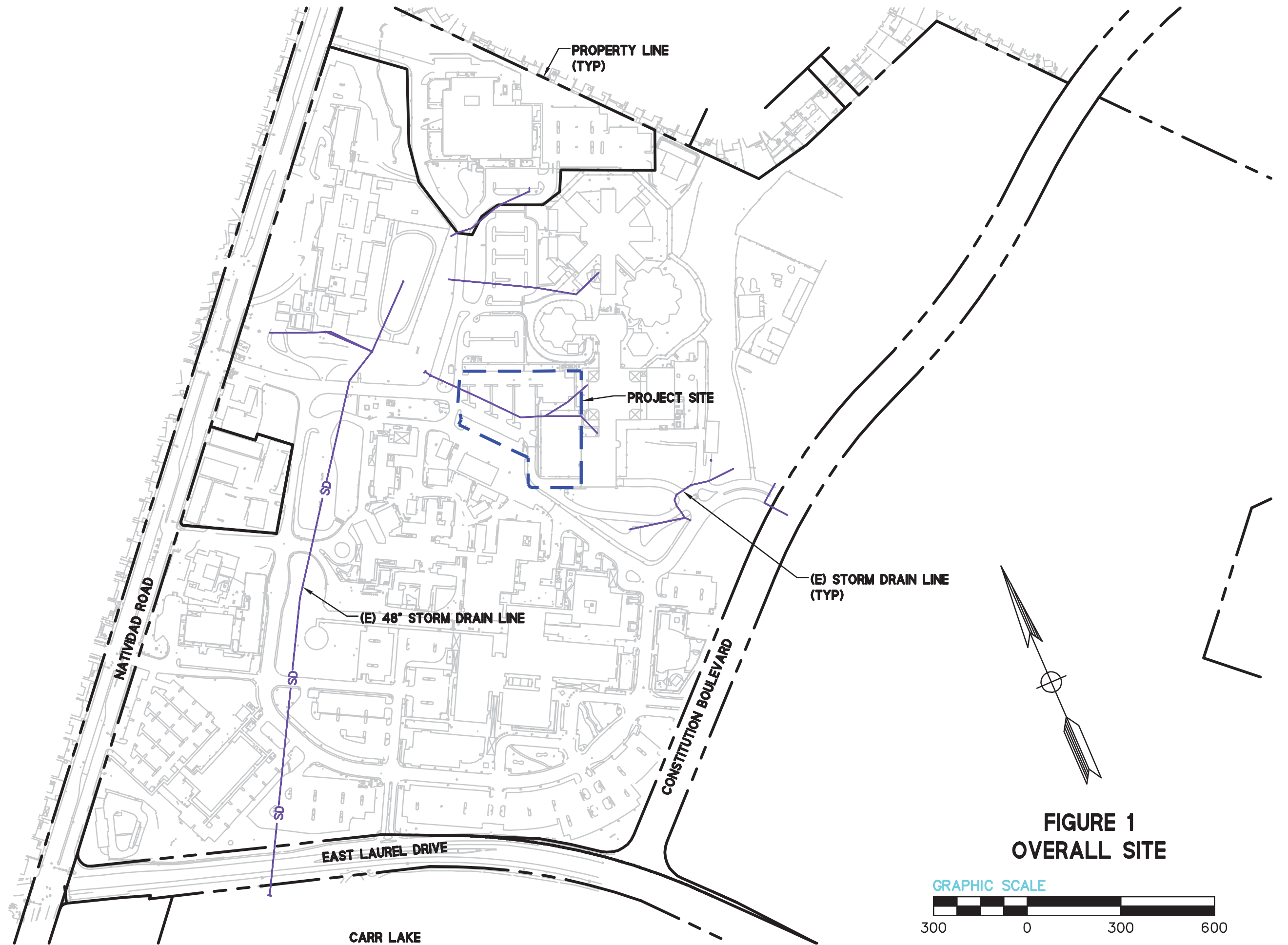
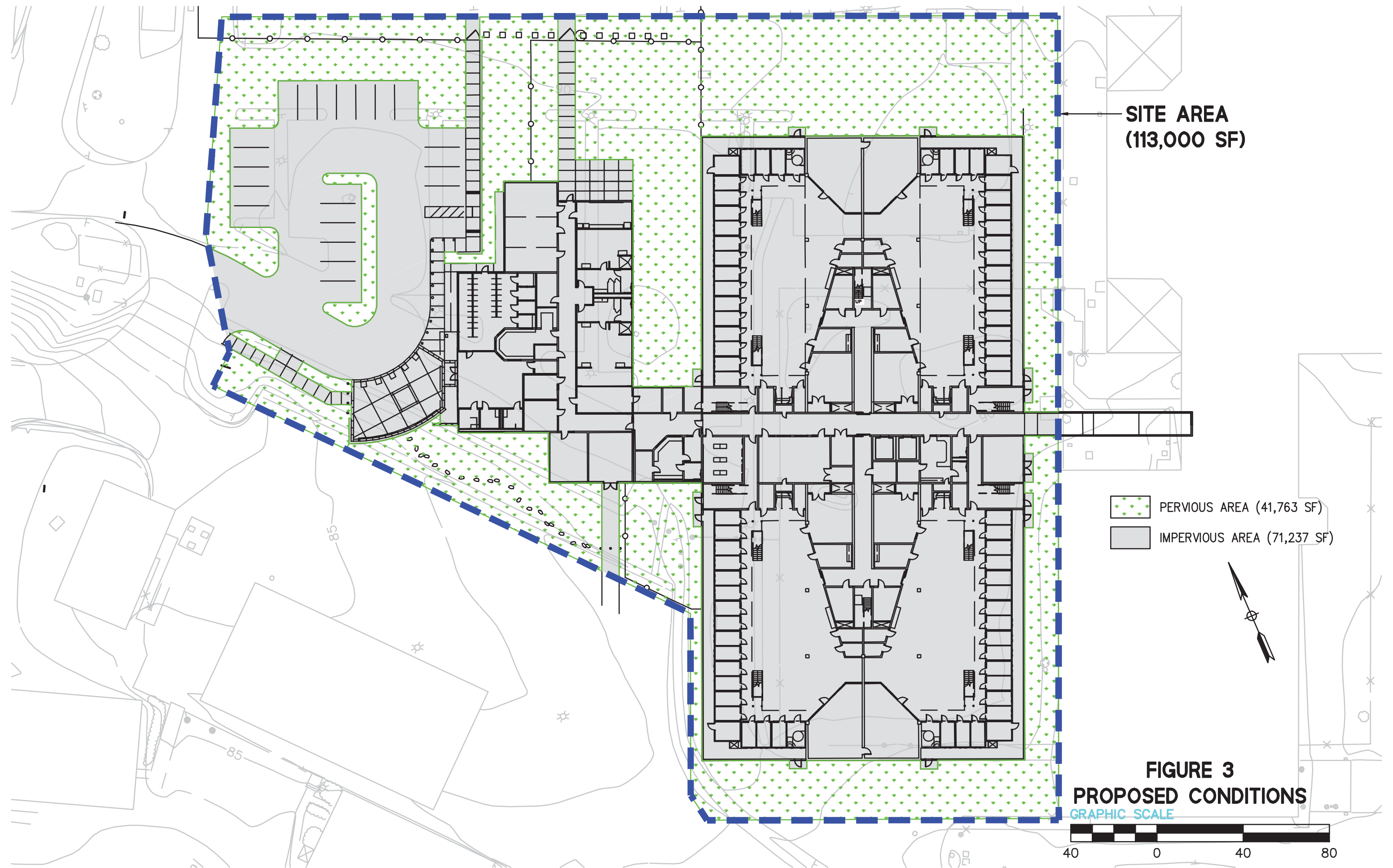

**FIGURE 1
OVERALL SITE**





J:\E\08080121\DWG\HYDROLOGY\Figure 2_Existing.dwg 23 Oct 2014 3:52:46pm chia





**SITE AREA
(113,000 SF)**

-  PERVIOUS AREA (41,763 SF)
-  IMPERVIOUS AREA (71,237 SF)

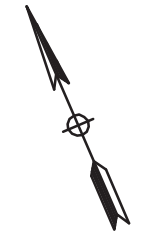

**FIGURE 3
PROPOSED CONDITIONS**
GRAPHIC SCALE

40 0 40 80

J:\Eg08080121\DWG\HYDROLOGY\Figure 4_Treatment.dwg 23 Oct 2014 3:54:56pm chua

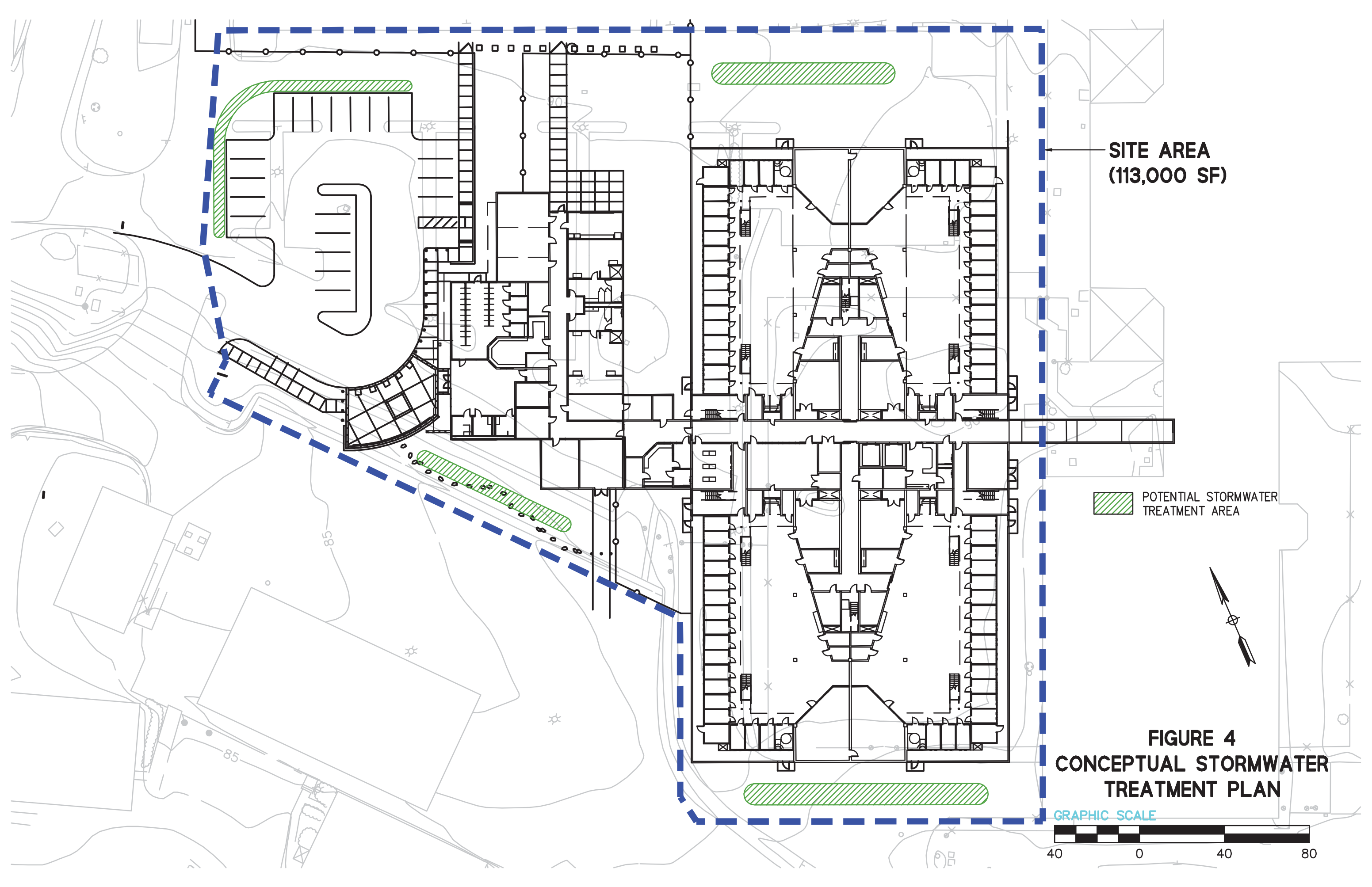

**SITE AREA
(113,000 SF)**

 **POTENTIAL STORMWATER
TREATMENT AREA**

**FIGURE 4
CONCEPTUAL STORMWATER
TREATMENT PLAN**

GRAPHIC SCALE
40 0 40 80

APPENDIX B

CONCEPTUAL STORM WATER CONTROL PLAN

CONCEPTUAL STORMWATER CONTROL PLAN

For

MONTEREY COUNTY JAIL ADDITION

COUNTY OF MONTEREY

APNs: 003-851-033-000, 003-851-034-000, 003-851-035-000 and 003-851-036-000

1410 Natividad Road

Salinas, California 93906

Prepared by:

Kimley»Horn

6 Quail Run Circle, Suite 102

Salinas, CA 93907

Phone: (916) 858-5800

April 29, 2015

Project Description

The Project site is located in the City of Salinas (City) within the County of Monterey (County). The proposed Monterey County Adult Jail Housing Addition (Project) located at the County's Detention facility on Natividad Road, bounded by East Laurel Road to the south, Natividad Road to the west and Constitution Boulevard to the east. In the area west of the existing jail, the site is mostly developed with buildings, roadways, and surface parking lots. Exhibit 2 in Appendix A shows the conceptual site plan. The project site is located within the following properties designated with the following Assessor's Parcel Numbers: 003-851-033-000, 003-851-034-000, 003-851-035-000 and 003-851-036-000. The project is owned by the County. As a result, the project applicant is the County.

Hydrologic Setting

The existing drainage patterns are influenced by the existing infrastructure, including but not limited to a series of gutters, catch basin inlets and storm drains. Runoff from the project site generally flows from the east to the west. Runoff is collected in a system of inlets and pipes that ultimately outfall to the grassy drainage swale to the west of the site. The grassy swale conveys flow to a 48-inch diameter pipe that flows south through the County property where it exits the property, crosses under East Laurel Drive and outfalls in to Carr Lake. Carr Lake outfalls to the Reclamation Ditch which flows northwesterly to the Pacific Ocean.

The site has minimal to no run-on from the surrounding areas. The existing vegetation is proposed to be removed and replaced with vegetation that requires minimal irrigation and within the bioretention basins, provides sufficient water quality treatment. The existing structures are to be removed from the project site.

According to the Clean Water Act Section 303(d) List, the Reclamation Ditch is impaired with the following pollutants: Ammonia, Chlorpyrifos, Copper, Diazion, Escherichia coli, Fecal Coliform, Low Dissolved Oxygen, Nitrate, Pesticides, pH, Priority Organics, Sediment Toxicity, Turbidity and Unknown Toxicity. The pollutants are primarily from agriculture and grazing-related sources. The anticipated pollutants from the Project are hydrocarbons, from the parking lots and roads; sediment, produced during construction; metals, from automobile use; and litter, from human activities.

Soils and Infiltration Rates

Butano Geotechnical Engineering, Inc. performed the design phase geotechnical investigation for the Project. In their October 2013 Geotechnical Investigation Design Phase report, they provide site characteristics and recommendations. The report indicates that the project site is primarily clayey soils with some sands and that the sands encountered were medium to very

dense and the clays were stiff to hard. According to the report, groundwater was encountered between 40 and 46 feet below the ground surface. See Appendix B for a copy of the Geotechnical Investigation – Design Phase.

There are no known unique geology and soil and/or groundwater contamination for the site. There are no known groundwater wells present on the site. The report identified the following geotechnical hazards for the site: fault surface rupture, intense seismic shaking, collateral seismic hazards, landside and erosion. Bedrock was not located in the site soil exploratory borings performed by Butano Geotechnical Engineering, Inc.

Supplemental analysis was performed to determine the infiltration capabilities of the site soil. The Draft Percolation Testing Report is included in Appendix B. From the infiltration evaluation, it was determined that no infiltration is possible on the site. According to the Web Soil Survey, the soil present on the site is hydrologic soil group D.

Stormwater Treatment Design Criteria

The Monterey County Jail Addition stormwater drainage design is based upon the December 2013 Stormwater Development Standards for New Development and Redevelopment Projects (SWDS) for the City. These standards were selected in order to meet the concerns of the County and the surrounding community regarding runoff during storm events. It was determined after evaluating the requirements set forth in the SWDS and the requirements of the County's Stormwater Technical Guide For Low Impact Design (2014), that the requirements of the SWDS is more conservative. The County standards require peak flow control through the 10-year rainfall event, whereas the SWDS requires peak flow control through the 100-year rainfall event.

These standards require that low impact development principles and stormwater Best Management Practices (BMPs) be included in the site design. These principles include but are not limited to the following:

- 1) Site layout
 - a) Minimize impervious areas
 - b) Limit disturbance of creeks and natural drainage features and provide setbacks according to Permit Provision L.1.d
 - c) Minimize compaction of highly permeable soils
 - d) Limit clearing and grading of native vegetation to the minimum needed to build the project and provide fire protection
- 2) Source control BMPs, where applicable, including:
 - a) Storm drain stenciling and signage

- b) Landscaping that minimizes irrigation and runoff – promotes surface infiltration and minimizes the use of pesticides and fertilizers
- c) Irrigation water application methods that minimize runoff of excessive irrigation water into storm drains

Using the SWDS methodology, the Threshold Determination Spreadsheet, included in Appendix A, indicates that the project is required to comply with Requirements 1, 4 and 5 as the total new and replaced impervious area in the project exceeds 22,500 square feet. The Threshold Determination Exhibit, Exhibit 1 in Appendix A, shows the new impervious area, replaced impervious area, new pervious area, and replaced pervious area.

The main design requirements are treatment design, peak management and runoff reduction. The treatment design is based on the impervious area, including, but not limited to, roofs, parking lots and sidewalks. The treatment design requirements will be met through flow or volume based treatment measures. Volume based treatment measures will be used to meet the runoff reduction and peak management requirements. The runoff reduction requirements require detention and infiltration. Due to the fact that infiltration is not possible on the site, the required detention volume will be detained and then metered off site through orifices that discharge flows at less than the pre-project peak flows. The lower flow provided by the flow control or peak control measures will be used to meter flow out of the detention area. The area required for runoff reduction is based on the sum all of the new impervious area and half of the replaced impervious area. Summarized below are a number of the key site design and stormwater treatment criteria that apply to the project.

- The design will use the Salinas Hydrology Model (SalinasHM) to perform a continuous simulation model to meet Post Development Peak flow requirements.
- The project will prevent offsite discharge from all rainfall events with up to 0.98 inches of rainfall in 24 hours (95th percentile rainfall event) through infiltration. For projects with the design infiltration rate is less than or equal to 0.3 inches per hour, a low flow control system with the capacity of no more than 0.01 cubic feet per second per tributary acre is permitted.
- To meet the peak management requirement, the site's Post Project Peak Flows cannot exceed the pre-project peak flows for 2- through 100-year rainfall events and perform a continuous simulation model provided by the City.
- The project will match the pre-project flow rates for the 100-year, 72-hour storm event imbedded within the 1 year rainfall record.

Opportunities and Constraints

One opportunity of the Project is the amount of impervious surface pre-project and the amount of impervious surface post project. There is an increase in the post-project impervious area.

However, with unmitigated pre-project impervious area, adding mitigation helps meet the stormwater design criteria.

One of the major constraints of the project is that the existing site soils have no infiltration capabilities. Butano Geotechnical Engineering, Inc. performed a percolation analysis to determine the infiltration capabilities of the site soil. The Draft Percolation Testing Report is included in Appendix B. From the infiltration evaluation, it was determined that no infiltration is possible on the site. According to the Web Soil Survey, the soil present on the site is hydrologic soil group D.

The project is not located in the area affected by water body setbacks per Section L of the NPDES permit as the project is located more than 100 feet from Gabilan Creek.

Using the Flood Insurance Rate Map (FIRM) from the area, it was determined that the project site is not within a FEMA Special Flood Hazard Area. The project site is located within an area classified by FEMA as Zone X. According to FEMA, Zone X is defined as “areas of 0.2% annual chance flood; areas of 1% annual chance flood with average depths of less than 1 foot or with drainage areas less than 1 square mile; and areas protected by levees from 1% annual flood.” A copy of the FIRM is located in Appendix A.

Stormwater Control Approach

The project consists of six Drainage Management Areas (DMA), see Appendix A for Exhibit 2 - Civil Site Plan Exhibit with Drainage Management Areas. Within each of the six DMAs, stormwater treatment measures have been designed to address Requirements 1, 4, and 5. Bioretention basins were used to treat the stormwater runoff in four of the six DMAs. Permeable Pavement was used to treat the incident rainfall in two DMAs to help ensure that those two DMAs are self-treating. The two self-treating DMAs 5 and 6 were combined into one DMA 5 in the Threshold Determination and BMP Sizing Spreadsheet. A seventh and eighth DMAs do not have treatment requirements as the work performed will be maintenance. It is expected that the pavement in this area will be damaged due to construction traffic.

Bioretention basins are proposed to provide the required water quality treatment. Each bioretention basin will provide six inches of surface ponding on top of three inches of mulch, 24 inches of engineered soil mix that meets the specifications of Appendix D in the SWDS and 12 inches of gravel with a perforated underdrain pipe.

The bioretention basin will also provide a source of detention to slow the stormwater discharges down so as to meet the peak flow requirements. During large storm events, when

the stormwater volume exceeds the storage provided in the basin, the additional volume will flow into the riser pipe and will be metered out to the existing stormwater system.

Bioretention Basins

Bioretention Basins are proposed as the primary treatment measure for four of the DMAs. This BMP was selected to treat the stormwater runoff, address runoff reduction requirements and to meet peak flow requirements.

Existing utility locations made including sufficient treatment area in bioretention basins difficult. As a result, two of the four proposed basins were broken up into two smaller basins. The two smaller proposed basins, that would have constituted one single basin had existing utilities allowed sufficient footprint, in each case are linked with a pipe to equalize the water surface between the two basins. See Exhibit 2 in Appendix A for the basin layout.

Permeable Pavement

Permeable pavement is proposed for sidewalks in two DMAs to the east side of the building. Permeable pavement is proposed there to minimize impervious area in those DMAs and to ensure that the DMAs remain self-treating with no runoff from impervious area contributing to that area. The permeable pavement sections are only required to capture the incident rainfall from the 95th percentile of 0.98 inches. The permeable pavement section in the City of Salinas Standard Plans will be sufficient for pedestrian access and to ensure that the DMA is self-treating.

Stormwater Control Measure Sizing – Sizing to Meet Requirement 5

A unit sizing approach based on Section 4.5 was used to comply with the Requirements 4 and 5 of the SWDS. The BMPs were initially sized using the Threshold Determination and BMP Sizing spreadsheet received from the City. For ease of use, the areas divided in the Threshold Determination spreadsheet were divided between impervious and pervious areas regardless of what type of pervious or impervious area. Table 1 summarizes the new and replaced project areas included in the Threshold Determination Spreadsheet included in Appendix A.

Table 1 Project Area Summary

New Impervious Area	34,520 square feet
Replaced Impervious Area	41,502 square feet
New Pervious Area	25,338 square feet
Replaced Pervious Area	23,404 square feet
Unchanging Impervious Area	66 square feet
Unchanged Pervious Area	229 square feet
Total Project Site Area	125,059 square feet

The sizes determined using the Threshold Determination and BMP Sizing spreadsheet were then brought into a SalinasHM model generated for the pre- and post-project site conditions. The SalinasHM model was run to ensure that the post-project conditions meet the Peak Flow requirements with appropriately sized orifices and weir overflow structures. The orifices, notch and weir, sized using the unit sizing approach were insufficient to convey flows from the bioretention basins without the basins overtopping. The orifices and notches were resized to meet peak flow requirements using SalinasHM. However, notches were not used to meter off the stormwater runoff. In each of the basins, half inch orifices, located one inch above the bottom of the basin, were used to meter out the flow. There is a slight increase in total impervious area due to the proposed project.

Within the Salinas HM precipitation data, the May 4, 1996 storm event is approximately equivalent to the 95th percentile storm event. Due to poor infiltration rates, it is not feasible to prevent discharge from the 95th percentile storm event. With infiltration being infeasible, the project will meter the 95th percentile storm event discharges out after the water has been treated in the bioretention basins. From the Salinas HM analysis, the pre-project discharge is larger than the post-project discharge.

To meet the peak flow requirements, SalinasHM results show that orifices were not necessary to restrict flow. The bioretention basins treatment and storage criteria provided sufficient mitigation for the peak flow requirements. In SalinasHM, the six DMAs were connected to a natural channel that represents the existing site stormwater discharge conditions.

The peak flow results from the SalinasHM model generated for this project are shown in the table below. The results from the SalinasHM model are included in Appendix A. The post-project peak flow is less than the pre-project peak flow for the 2-year through the 100-year storm events.

Since the project is located in the Carr Lake watershed, peak flow rates from the 100-year, 72-hour storm event were also analyzed. The modeled discharge hydrographs for the pre-

project and mitigated project conditions during the 100-year, 72-hour storm event were analyzed. The results from this analysis show that the post-project peak flow is less than the pre-project peak flow for this storm event.

Table 2 Peak Flow Results

Rainfall Event	Pre-Project Peak Flow (cfs)	Post-Project Peak Flow (cfs)
2-Year	0.560	0.125
5-Year	0.759	0.282
10-Year	0.884	0.432
25-Year	1.034	0.680
100-Year	2.140	1.684
100-Year (72-Hour)	2.140	1.694

Stormwater Quality Volume

The requirements of Monterey County, as defined within the Stormwater Technical Guide for Low Impact Design (2014), have been incorporated into the project design in order to meet stormwater water quality volumetric requirements for the project site. The Technical Guide calls for the prevention of offsite discharge from events up to the 95th percentile event and to retain this water onsite. The results from this analysis is provided in the table below.

Table 3 Stormwater Quality Volume Results

DMA	Minimum Required Storage Volume (ft ³)	Minimum Required Storage Volume (Gal)
DMA 1	1,334	9,978
DMA 2	2,203	16,748
DMA 3	1,658	12,402
DMA 4	1,215	9,088
Total	6,410	48,216

These minimum required storage volumes will be retained onsite as a part of the onsite drainage system. This may be achieved via a variety of methods which include an onsite storage and reuse system since infiltration is not possible within the project site.

Operation and Maintenance Guidance

Operation and Maintenance of the BMPs is important to maintain the effectiveness of the stormwater treatment measures. The following inspection and maintenance measures are suggested to maintain the effectiveness of the bioretention basins and porous concrete sidewalks

Bioretention Basins

Inspection and Maintenance

Primary maintenance activities include vegetation management and sediment removal. Mosquito control is also a concern in extended detention basins that are designed to include pools of standing water. The typical maintenance requirements include:

- Conduct semi-annual inspection as follows:
 - Evaluate the health of the vegetation and remove and replace any dead or dying plants.
 - Remove any trash and debris.
 - Inspect the outlet, embankments, dikes, berms, and side slopes for structural integrity and signs of erosion or rodent burrows. Fill in any holes detected in the side slopes.
 - Examine outlets and overflow structures and remove any debris plugging the outlets.
 - Identify and minimize any sources of sediment and debris. Check rocks or other erosion control and replace, if necessary.
 - Check inlets to make sure piping is intact and not plugged. Remove accumulated sediment and debris near the inlet. Ensure that engineered energy dissipation is functioning adequately by checking for evidence of local scour around the inlet.
 - Inspect for standing water and correct any problems that prevent the extended detention basin from draining as designed.
 - Confirm that any fences around the facility are secure.
- Maintenance activities at the bottom of the basin shall NOT be performed with heavy equipment, which would compact the soil and limit infiltration.
- Harvest vegetation annually, during the summer.
- Trim vegetation at beginning and end of the wet season and inspect monthly to prevent establishment of woody vegetation and for aesthetic and mosquito control reasons.
- Invasive vegetation contributing up to 25% of vegetation of all species shall be removed and replaced.
- Dead vegetation shall be removed to maintain less than 10% of area coverage or when vegetative filter strip function is impaired. Vegetation shall be replaced immediately to control erosion where soils are exposed and within 3 months to maintain cover density.

- Avoid the use of pesticides and quick release synthetic fertilizers, and follow the principles of integrated pest management (IPM) followed. Check with the local jurisdiction for any local policies regarding the use of pesticides and fertilizers.
- Remove sediment from the forebay when the sediment level reaches the level shown on the fixed vertical sediment marker.
- Remove accumulated sediment and regrade about every 10 years or when the accumulated sediment volume exceeds 10 % of the basin volume.

Porous Concrete

Inspection and Maintenance

- Accumulated debris and litter shall be routinely removed as a source control measure.
- Inspect porous asphalt and concrete several times during the first few storms to insure proper infiltration and drainage. After the first year, inspect at least once a year.
- Permeable pavements and materials shall be cleaned with a vacuum-type street cleaner a minimum of twice a year (before and after the rainy season).
- Hand held pressure washers can be effective for cleaning the void spaces of small areas and shall follow vacuum cleaning.
- Maintenance personnel must be instructed not to seal or pave with non-porous materials.
- Pervious pavements must not be sanded in the winter to avoid clogging the void spaces



Appendix A



MONTEREY COUNTY JAIL ADDITION

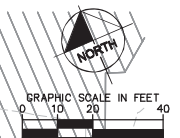

LEGEND:

- ASPHALT PAVEMENT
- LANDSCAPE AREA
- DECOMPOSED GRANITE
- SAWCUT LINE
- PARKING COUNT

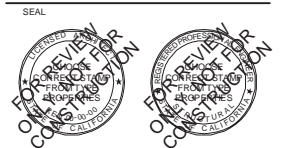
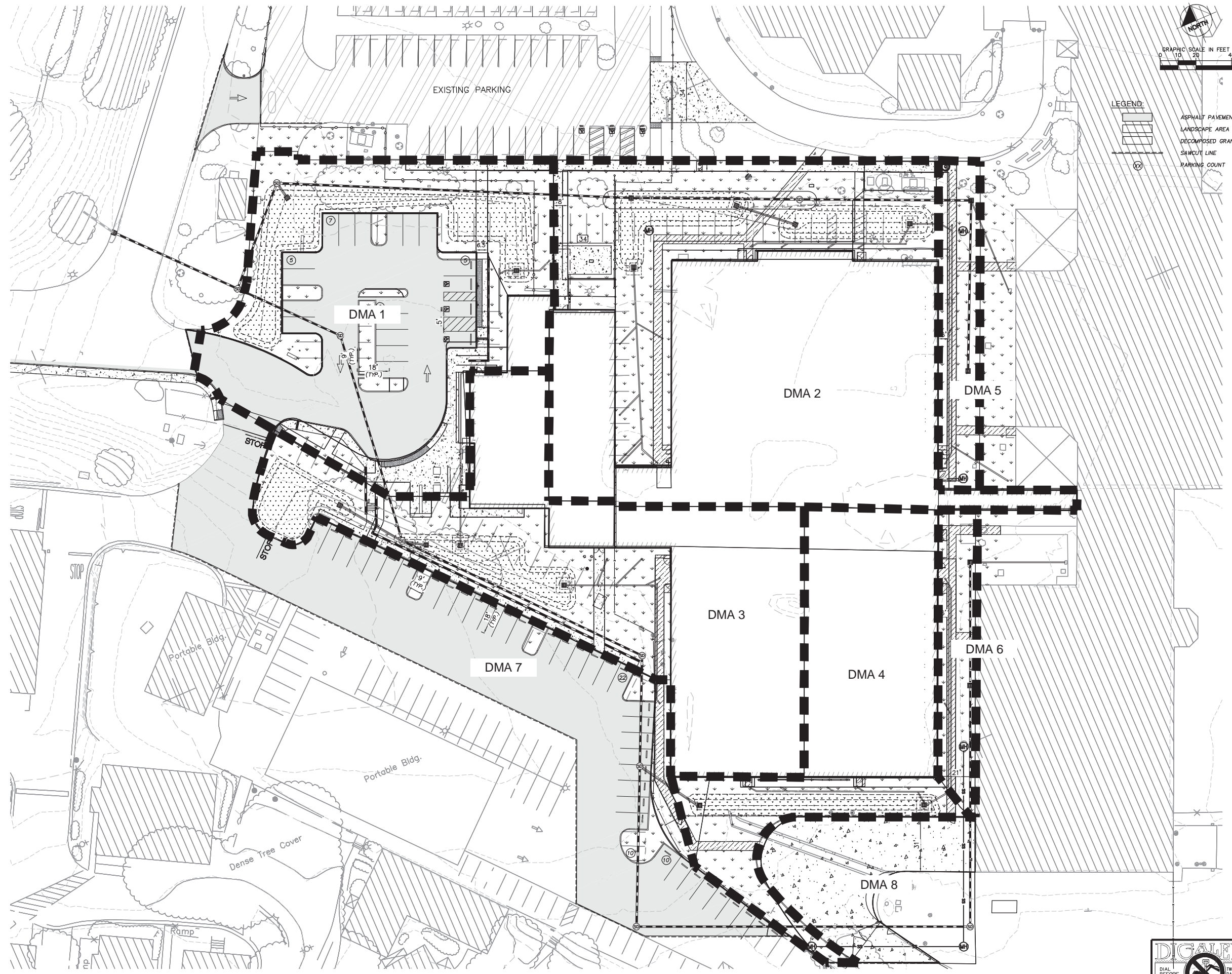

PROJECT
MONTEREY JAIL HOUSING ADDITION

1410 Natividad Road
SALINAS, CA 93906

CLIENT
MONTEREY COUNTY JAIL

MARK	DATE	DESCRIPTION

**100% DD SUBMITTAL
APRIL 13, 2015
NOT FOR CONSTRUCTION**

MANAGEMENT

LIONAKIS PROJECT NO.:	012388
CLIENT PROJECT NO.:	087429005
DRAWN BY:	CD
CHECKED BY:	SS
COPYRIGHT:	LIONAKIS 2013

AGENCY
AB800
**CALIFORNIA STATE FIRE MARSHAL
APPROVED**

Approval of this plan does not authorize or approve any omission or deviation from applicable regulations. Final approval is subject to field inspections. One set of approved plans shall be available on the project site at all times.

Reviewed by: _____

TITLE
CIVIL SITE PLAN EXHIBIT

SHEET
EXHIBIT 2



K:\SAC_DEV\097429005 MONTEREY COUNTY JAIL ADDITION\08 CADD\EXHIBITS\BMP_SIZING\THRESHOLD\HBIT_20150429.DWG

NOTES TO USERS

This map is for use in administering the National Flood Insurance Program. It does not necessarily identify all areas subject to flooding, particularly from local drainage sources of small size. The community map repository should be consulted for possible updated or additional flood hazard information.

To obtain more detailed information in areas where Base Flood Elevations (BFEs) and/or floodways have been determined, users are encouraged to consult the Flood Profiles and Floodway Data and/or Summary of Stillwater Elevations tables contained within the Flood Insurance Study (FIS) report that accompanies this FIRM. Users should be aware that BFEs shown on the FIRM represent rounded whole-foot elevations. These BFEs are intended for flood insurance rating purposes only and should not be used as the sole source of flood elevation information. Accordingly, flood elevation data presented in the FIS report should be utilized in conjunction with the FIRM for purposes of construction and/or floodplain management.

Coastal Base Flood Elevations shown on this map apply only landward of 0.0' North American Vertical Datum of 1988 (NAVD 88). Users of this FIRM should be aware that coastal flood elevations are also provided in the Summary of Stillwater Elevations tables in the Flood Insurance Study report for this jurisdiction. Elevations shown in the Summary of Stillwater Elevations tables should be used for construction and/or floodplain management purposes when they are higher than the elevations shown on this FIRM.

Boundaries of the floodways were computed at cross sections and interpolated between cross sections. The floodways were based on hydraulic considerations with regard to requirements of the National Flood Insurance Program. Floodway widths and other pertinent floodway data are provided in the Flood Insurance Study report for this jurisdiction.

Certain areas not in Special Flood Hazard Areas may be protected by flood control structures. Refer to Section 2.4 "Flood Protection Measures" of the Flood Insurance Study report for information on flood control structures for this jurisdiction.

The projection used in the preparation of this map was Universal Transverse Mercator (UTM) Zone 10. The horizontal datum was NAD 83, GRS80 spheroid. Differences in datum, spheroid, projection or UTM zones used in the production of FIRMs for adjacent jurisdictions may result in slight positional differences in map features across jurisdiction boundaries. These differences do not affect the accuracy of this FIRM.

Flood elevations on this map are referenced to the North American Vertical Datum of 1988. These flood elevations must be compared to structure and ground elevations referenced to the same vertical datum. For information regarding conversion between the National Geodetic Vertical Datum of 1929 and the North American Vertical Datum of 1988, visit the National Geodetic Survey website at <http://www.ngs.noaa.gov> or contact the National Geodetic Survey at the following address:

NGS Information Services
NOAA, NNGS12
National Geodetic Survey
SSM0-3, #9202
1315 East-West Highway
Silver Spring, Maryland 20910-3282
(301) 713-3242

To obtain current elevation, description, and/or location information for bench marks shown on this map, please contact the Information Services Branch of the National Geodetic Survey at (301) 713-3242, or visit its website at <http://www.ngs.noaa.gov>.

Base map information shown on this FIRM was derived from U.S. Geological Survey Digital Orthophoto Quadrangles produced at a scale of 1:12,000 from photography dated 1987 or later.

This map reflects more detailed and up-to-date stream channel configurations than those shown on the previous FIRM for this jurisdiction. The floodplains and floodways that were transferred from the previous FIRM may have been adjusted to conform to these new stream channel configurations. As a result, the Flood Profiles and Floodway Data tables in the Flood Insurance Study Report (which contains authoritative hydraulic data) may reflect stream channel distances that differ from what is shown on this map.

Corporate limits shown on this map are based on the best data available at the time of publication. Because changes due to annexations or de-annexations may have occurred after this map was published, map users should contact appropriate community officials to verify current corporate limit locations.

Please refer to the separately printed Map Index for an overview map showing the layout of map panels; community map repository addresses; and a Listing of Communities table containing National Flood Insurance Program dates for each community as well as a listing of the panels on which each community is located.

Contact the FEMA Map Service Center at 1-800-358-9616 for information on available products associated with this FIRM. Available products may include previously issued Letters of Map Change, a Flood Insurance Study report, and/or digital versions of this map. The FEMA Map Service Center may also be reached by Fax at 1-800-358-9620 and its website at <http://msc.fema.gov>.

If you have questions about this map or questions concerning the National Flood Insurance Program in general, please call 1-877-FEMA MAP (1-877-336-2627) or visit the FEMA website at <http://www.fema.gov>.



LEGEND

SPECIAL FLOOD HAZARD AREAS SUBJECT TO INUNDATION BY THE 1% ANNUAL CHANCE FLOOD

The 1% annual flood (100-year flood), also known as the base flood, is the flood that has a 1% chance of being equaled or exceeded in any given year. The Special Flood Hazard Area is the area subject to flooding by the 1% annual chance flood. Areas of Special Flood Hazard include Zones A, AE, AH, AO, AR, A99, V, and VE. The Base Flood Elevation is the water-surface elevation of the 1% annual chance flood.

ZONE A No Base Flood Elevations determined.

ZONE AE Base Flood Elevations determined.

ZONE AH Flood depths of 1 to 3 feet (usually areas of ponding); Base Flood Elevations determined.

ZONE AO Flood depths of 1 to 2 feet (usually sheet flow on sloping terrain); average depths determined. For areas of alluvial fan flooding, velocities also determined.

ZONE AR Special Flood Hazard Area formerly protected from the 1% annual chance flood by a flood control system that was subsequently destroyed. Zone AR indicates that the former flood control system is being restored to provide protection from the 1% annual chance or greater flood.

ZONE A99 Area to be protected from 1% annual chance flood by a Federal flood protection system under construction; no Base Flood Elevations determined.

ZONE V Coastal flood zone with velocity hazard (wave action); no Base Flood Elevations determined.

ZONE VE Coastal flood zone with velocity hazard (wave action); Base Flood Elevations determined.

FLOODWAY AREAS IN ZONE AE

The floodway is the channel of a stream plus any adjacent floodplain areas that must be kept free of encroachment so that the 1% annual chance flood can be carried without substantial increases in flood heights.

OTHER FLOOD AREAS

ZONE X Areas of 0.2% annual chance flood; areas of 1% annual chance flood with average depths of less than 1 foot or with drainage areas less than 1 square mile; and areas protected by levees from 1% annual chance flood.

OTHER AREAS

ZONE X Areas determined to be outside the 0.2% annual chance floodplain.

ZONE D Areas in which flood hazards are undetermined, but possible.

COASTAL BARRIER RESOURCES SYSTEM (CBRS) AREAS

OTHERWISE PROTECTED AREAS (OPAs)

CBRS areas and OPAs are normally located within or adjacent to Special Flood Hazard Areas.

1% annual chance floodplain boundary
0.2% annual chance floodplain boundary
Floodway boundary
Zone D boundary
CBRS and OPA boundary
Boundary dividing Special Flood Hazard Area Zones and boundary dividing Special Flood Hazard Areas of different Base Flood Elevations, flood depths or flood velocities.
Base Flood Elevation line and value; elevation in feet*
Base Flood Elevation value where uniform within zone; elevation in feet*

* Referenced to the North American Vertical Datum of 1988

○ Cross section line
○ Transsect line
87°07'45", 32°22'30" Geographic coordinates referenced to the North American Datum of 1983 (NAD 83), Western Hemisphere
100-meter Universal Transverse Mercator grid values, zone 10
76°N
600000 FT
DX5510 x
● M1.5 River Mile

MAP REPOSITORY
Refer to listing of Map Repositories on Map Index.

EFFECTIVE DATE OF COUNTYWIDE FLOOD INSURANCE RATE MAP
April 2, 2009

EFFECTIVE DATE(S) OF REVISION(S) TO THIS PANEL

For community map revision history prior to countywide mapping, refer to the Community Map History table located in the Flood Insurance Study report for this jurisdiction.

To determine if flood insurance is available in this community, contact your insurance agent or call the National Flood Insurance Program at 1-800-638-6623.

MAP SCALE 1" = 500'
250 0 500 1000 FEET
150 0 150 300 METERS

NATIONAL FLOOD INSURANCE PROGRAM

PANEL 0209G

FIRM

FLOOD INSURANCE RATE MAP

MONTEREY COUNTY, CALIFORNIA AND INCORPORATED AREAS

PANEL 209 OF 2050
(SEE MAP INDEX FOR FIRM PANEL LAYOUT)

CONTAINS

COMMUNITY	NUMBER	PANEL	SUFFIX
MONTEREY COUNTY	060195	0209	G
SALINAS, CITY OF	060202	0209	G

Notice to User: The Map Number shown below should be used when placing map orders; the Community Number shown above should be used on insurance applications for the subject community.

MAP NUMBER
06053C0209G

EFFECTIVE DATE
APRIL 2, 2009

Federal Emergency Management Agency

Infiltration Feasibility Worksheet

City of Salinas

Stormwater Development Standards

Complete this worksheet for Projects subject to Requirement 3 to determine the feasibility of treating the stormwater runoff generated by the 85th percentile storm event through either direct or indirect infiltration BMPs.

Complete this worksheet for Projects subject to Requirement 4 to determine the feasibility of treating and retaining the stormwater runoff generated by the 95th percentile storm event by employing direct or indirect infiltration BMPs. Size BMP(s) selected by following the procedures in Section 4 of the City of Salinas Stormwater Development Standards for New Development and Redevelopment Projects.

If infiltration feasibility differs among the project Drainage Management Areas (DMAs), this worksheet shall be filled out for each condition.

This Infiltration Feasibility worksheet identifies conditions on project sites, other than infiltration rates, that would prohibit infiltration. For projects with low design infiltration rates, where infiltration is deemed feasible by this worksheet, the project will be designed to permit incidental disposal but shall not be intended for total infiltration of stormwater runoff.

1. Enter Project Data.

- 1.1 Project Name: Monterey County Jail Addition
- 1.2 Project Address: 1410 Natividad Road, Salinas, California 93906
- 1.3 Applicant/Agent Name: County of Monterey
- 1.4 Applicant/Agent Address: 168 West Alisal Street Salinas, California 93901
- 1.5 Applicant/Agent Email: _____ Applicant / Agent Phone: _____
- 1.6 Evaluated DMA(s): ALL (1-6)

2. Evaluate infiltration feasibility.

Check "Yes" or "No" to indicate whether the following conditions apply to the project. If "Yes" is checked for any question, then infiltration is infeasible, and you can continue to Item 3.1 without answering any further questions in Section 2. If all of the answers in Section 2 are "No," then infiltration is feasible. If infiltration is infeasible, STOP after Section 3. If infiltration is feasible, proceed to Section 4 to determine direct infiltration feasibility. If all of the answers in Section 4 are "No," then direct infiltration is feasible.

- | | Yes | No |
|--|--------------------------|-------------------------------------|
| 2.1 Would infiltration facilities at this site conflict with the location of existing or proposed underground utilities or easements, or would the siting of infiltration facilities at this site result in their placement on top of underground utilities, or otherwise oriented to underground utilities, such that they would discharge to the utility trench, restrict access, or cause stability concerns? (If yes, attach evidence documenting this condition.) | <input type="checkbox"/> | <input checked="" type="checkbox"/> |
| 2.2 Is there a water well within 100 feet of the location where an infiltration device would be constructed? (If yes, attach map showing the well.) | <input type="checkbox"/> | <input checked="" type="checkbox"/> |
| 2.3 Would construction of an infiltration device require that it be located less than 100 feet away from a septic system, other potential underground source of pollution, or less than 500 feet away from an underground fuel tank with hazardous materials? (If yes, attach evidence documenting this claim.) | <input type="checkbox"/> | <input checked="" type="checkbox"/> |
| 2.4 Is there a seasonal high groundwater that would be within 5 feet of the base of an infiltration device constructed on the site? (If yes, attach documentation of high groundwater.) | <input type="checkbox"/> | <input checked="" type="checkbox"/> |
| 2.5 Is there a documented concern that there is a potential on the site for soil or groundwater pollutants to be mobilized or is there any known groundwater contamination plume that could be further dispersed by infiltration at the subject location? If known contaminated plume is within 500 feet, evaluate to determine mobilization concern. (If yes, attach documentation of mobilization concerns.) | <input type="checkbox"/> | <input checked="" type="checkbox"/> |

Infiltration Feasibility Worksheet

- | | Yes | No |
|---|--------------------------|-------------------------------------|
| 2.6 Do local water district or other agency's policies or guidelines regarding the locations where infiltration may occur, the separation from seasonal high groundwater, or setbacks from potential sources of pollution prevent infiltration devices from being implemented at this site? (If yes, attach evidence documenting this condition.) | <input type="checkbox"/> | <input checked="" type="checkbox"/> |

3. Results of Feasibility Determination

- | | Infeasible | Feasible |
|--|--------------------------|-------------------------------------|
| 3.1 Based on the results of the Section 2 feasibility analysis, infiltration is (check one): | <input type="checkbox"/> | <input checked="" type="checkbox"/> |

If infiltration is feasible, proceed to Section 4 to determine if Direct Infiltration is feasible. If infiltration is infeasible, stop here.

4. Is Direct Infiltration Feasible?

- | | Yes | No |
|---|--------------------------|-------------------------------------|
| 4.1 Is there a seasonal high groundwater that would be within 10 feet of the base of an infiltration device constructed on the site? (If yes, attach documentation of high groundwater.) | <input type="checkbox"/> | <input checked="" type="checkbox"/> |
| 4.2 Are there land uses that pose a high threat to water quality – including but not limited to industrial and light industrial activities, high vehicular traffic (i.e., 25,000 or greater average daily traffic on a main roadway or 15,000 or more average daily traffic on any intersecting roadway), automotive repair shops, car washes, fleet storage areas, or nurseries? (If yes, attach evidence documenting this claim.) | <input type="checkbox"/> | <input checked="" type="checkbox"/> |
| 4.3 Is there a significant potential for spills or highly polluted runoff to be conveyed to the infiltration system? | <input type="checkbox"/> | <input checked="" type="checkbox"/> |
| 4.4 Is there a water well within 150 feet of the location where an infiltration device would be constructed? (If yes, attach map showing the well.) | <input type="checkbox"/> | <input checked="" type="checkbox"/> |
| 4.5 Would construction of an infiltration device require that it be located less than 150 feet away from a septic system, other potential underground source of pollution? (If yes, attach evidence documenting this claim.) | <input type="checkbox"/> | <input checked="" type="checkbox"/> |

5 Results of Direct Infiltration Feasibility Determination

- | | Infeasible | Feasible |
|---|--------------------------|-------------------------------------|
| 5.1 Based on the results of the Section 4 feasibility analysis, direct infiltration is (check one): | <input type="checkbox"/> | <input checked="" type="checkbox"/> |

Name of Applicant (Print)

Name of Applicant (Sign)

Date

Salinas Stormwater Development Standards

Please see the instructions tab before using this Workbook.

Project Name:	Monterey County Jail	
Number of Drainage Management Areas:	5	
SWDS Requirement Set	Requirement 5 - For Preliminary Design Only	
Project Site Area	125059	ft
Total Accounted for Area	124840	ft
Percentage of Total Site Unaccounted For	0%	
Percentage of Pervious Area Unaccounted For	0%	
	Required	Provided
Impervious Area for Treatment Design	76088	76088
Impervious Area for Peak Management	9182	35277
Impervious Area for Runoff Reduction	55271	64113

Land Cover	Area	C-Value	CA
Impervious areas including roofs, pavements and areas with impermeable barriers	76088	1	76088
BMPS (to account for directly incident rainfall)	11174	1	11174
Crushed aggregate	0	0.4	0
Sod and areas with non-amended hydrologic soil group D soils	0	0.35	0
Other pervious area	37578	0.1	3757.8
Total	124840	0.729	91019.8

	Cell/Sheet Reference
	B11
	B14
	B16
	B17
	B19
Treatment Type	B5
Impervious Area Treated (ft ²)	
Is this BMP being designed for Peak Management?	B27
Treatment Design Impervious Area	
Peak Management Impervious Area	
Runoff Reduction Impervious Area	
BMP Drawdown Time (Max to Orifice)	B29

DMA 1	DMA 2	DMA 3	DMA 4
16938	28836	18339	11826
3940	3360	3121	753
0	0	0	0
0	0	0	0
7547	10791	6738	4924
Volume Based	Volume Based	Volume Based	Flow Based
16938	28836	18339	11826
Yes	No	Yes	No
16938	28836	18339	11826
16938	0	18339	0
16938	28836	18339	0
167.6598024	174.2903688	175.5280158	558.3149022

DMA 5

149

0

0

0

7578

Self Treating

149

No

149

0

0

#N/A

Threshold Determination Process Spreadsheet

Project Name:	Monterey County Jail	
Street address:	1410 Natividad Road, Salinas California	
APN:	003-851-033-000, 003-8	Project Type: Commercial
Project Site Area:	125,059	ft ²
Pre-Project Impervious Area:	66,906	ft ²
Unchanging Impervious Area:	66	ft ²
Post-Project Impervious Area:	76,088	ft ²
Unchanging Pervious Area:	229	ft ²

Note: Applicant may use the 'All' category or provide details, except 'Turf' must be listed separately.

Impervious Area

	Replaced		
Building Footprint:	34,520	ft ²	41,502 ft ²
Parking:		ft ²	
Driveways:		ft ²	
Patios:		ft ²	
Sidewalks:		ft ²	
All or Other:		ft ²	
Total:	34,520	ft²	41,502 ft ²
Total New and Replaced Impervious Area:			76,022 ft ²

New impervious area is impervious area placed on existing pervious area and replaced impervious area is where existing impervious area is modified.

Pervious Area

	New	Replaced	
Turf:	25,338	ft ²	23,404 ft ²
Landscaping:		ft ²	
Parking:		ft ²	
Driveways:		ft ²	
Patios:		ft ²	
Sidewalks:		ft ²	
All or Other, except Turf:		ft ²	
Total:	25,338	ft²	23,404 ft ²
Total New and Replaced Pervious Area:			48,742 ft ²

New pervious area is pervious area placed on existing impervious area and replaced pervious area is where existing pervious area is modified.

Conclusion

Is the project in an Urban Sustainability Area? No

Is there existing detention on the site? No

Applicable Requirement:	1, 4 & 5
Impervious Area for Treatment Design:	76088 ft ²
Impervious Area for Peak Management:	9182 ft ²
Impervious Area for Runoff Reduction:	55271 ft ²

See Section 4 for calculation procedures

Area check, set F11+E24+C37-C11=0:	-
Area check, set C9-C11-E37-C24≥0:	229
Area check, set C9-C13-E39≥0:	229
Land disturbance estimate:	124,764 ft ²

Salinas Stormwater Development Standards

Drainage Management Area 4

Project Name:	Monterey County Jail
SWDS Requirement Set	Requirement 5 - For Preliminary Design Only
Treatment Type	Flow Based
BMP Tributary Area	17503 ft ²
Surface Area within BMP	753 ft ²
Design Infiltration Rate	0 in/hr (enter "infeasible" or value) Value used will be value equal to or less than design value from table.

Land Cover	Area	C-Value	CA
Impervious areas including roofs (including green roofs), pavements and areas with impermeable barriers	11826	1	11826
BMPs (to account for directly incident rainfall) (excluding green roofs)	753	1	753
Crushed aggregate	0	0.4	0
Sod (turf) and areas with non-amended hydrologic soil group D soils	0	0.35	0
Other previous area	4924	0.1	492.4
	17503	0.7468	13071.40

For Flow Based Treatment

Flow Based Treatment BMP Type	Biofilter or Planter
Surface Area at Overflow	753 square feet
Elevation at Overflow	87.50 ft
Elevation of Orifice Centerline	83.75 ft
BMP Tributary Area	13071.40 ft ²
Water Quality Flow Rate (WQ ₂)	0.060 cfs
Area Required	518.53 sq ft
Area Provided	753.00 sq ft
Orifice Diameter	1.085 in
Elevation at Orifice Bottom	83.70 ft

Note: If Biofiltration is the pre-treatment BMP prior to direct infiltration, 18 inches of soil topped with 3 inches of mulch will provide sufficient treatment

Salinas Stormwater Development Standards

Drainage Management Area 5

Project Name:	Monterey County Jail
SWDS Requirement Set	Requirement 5 - For Preliminary Design Only
Treatment Type	Self Treating
BMP Tributary Area	7727 ft ²
Surface Area within BMP	0 ft ²
Design Infiltration Rate	0 in/hr (enter "infeasible" or value) Value used will be value equal to or less than design value from table.

Land Cover	Area	C-Value	CA
Impervious areas including roofs (including green roofs), pavements and areas with impermeable barriers	149	1	149
BMPS (to account for directly incident rainfall) (excluding green roofs)	0	1	0
Crushed aggregate	0	0.4	0
Sod (turf) and areas with non-amended hydrologic soil group D soils	0	0.35	0
Other previous area	7578	0.1	757.8
	7727	0.1174	906.80

SalinasHM
PROJECT REPORT

General Model Information

Project Name: MontereyCountyJailHM1_withOrificeML
Site Name: Monterey County Jail
Site Address:
City:
Report Date: 3/24/2015
Gage:
Data Start: 1978/10/01
Data End: 2008/09/30
Timestep: Hourly
Precip Scale: 1.00
Version: 2014/12/10

POC Thresholds

Low Flow Threshold for POC1: 50 Percent of the 2 Year
High Flow Threshold for POC1: 50 Year

Low Flow Threshold for POC2: 50 Percent of the 2 Year
High Flow Threshold for POC2: 50 Year

Low Flow Threshold for POC3: 50 Percent of the 2 Year
High Flow Threshold for POC3: 50 Year

Low Flow Threshold for POC4: 50 Percent of the 2 Year
High Flow Threshold for POC4: 50 Year

Low Flow Threshold for POC5: 50 Percent of the 2 Year
High Flow Threshold for POC5: 50 Year

Landuse Basin Data

Predeveloped Land Use

Basin 1

Bypass: No

GroundWater: No

Pervious Land Use Acres
C D,Urban,Flat(0-5%) 1.38

Pervious Total 1.38

Impervious Land Use Acres
Sidewalks,Flat(0-5%) 1.63
Parking,Flat(0-5%) 0.07

Impervious Total 1.7

Basin Total 3.08

Element Flows To:
Surface Interflow Groundwater

Mitigated Land Use

Bypass: No

GroundWater: No

Pervious Land Use	Acres
C D,Urban,Mod(5-10%)	0.203
C D,Urban,Flat(0-5%)	0.023

Pervious Total 0.226

Impervious Land Use	Acres
Roof Area	0.023
Parking,Flat(0-5%)	0.367

Impervious Total 0.39

Basin Total 0.616

Element Flows To:

Surface	Interflow	Groundwater
Surface Bio Swale 1	Surface Bio Swale 1	

DMA 4

Bypass:	No
GroundWater:	No
Pervious Land Use C D, Urban, Flat(0-5%)	Acres 0.189
Pervious Total	0.189
Impervious Land Use Roof Area Sidewalks, Flat(0-5%)	Acres 0.259 0.136
Impervious Total	0.395
Basin Total	0.584

Element Flows To:

Surface	Interflow	Groundwater
Surface Bio Swale 4	Surface Bio Swale 4	

DMA 2

Bypass: No

GroundWater: No

Pervious Land Use Acres

C D,Urban,Flat(0-5%) 0.046

C D,Urban,Mod(5-10%) 0.288

Pervious Total 0.334

Impervious Land Use Acres

Roof Area 0.61

Sidewalks,Flat(0-5%) 0.056

Impervious Total 0.666

Basin Total 1

Element Flows To:

Surface Interflow Groundwater

Surface Bio Swale 2 Surface Bio Swale 2

DMA 3

Bypass: No

GroundWater: No

Pervious Land Use	Acres
C D,Urban,Flat(0-5%)	0.0516
C D,Urban,Mod(5-10%)	0.115

Pervious Total 0.1666

Impervious Land Use	Acres
Roof Area	0.379
Sidewalks,Flat(0-5%)	0.042

Impervious Total 0.421

Basin Total 0.5876

Element Flows To:

Surface	Interflow	Groundwater
Surface Bio Swale 3	Surface Bio Swale 3	

DMA 5A

Bypass: No

GroundWater: No

Pervious Land Use Acres
C D,Urban,Mod(5-10%) 0.149

Pervious Total 0.149

Impervious Land Use Acres
Sidewalks,Flat(0-5%) 0.0096

Impervious Total 0.0096

Basin Total 0.1586

Element Flows To:

Surface	Interflow	Groundwater
Channel 1	Channel 1	

DMA 5B

Bypass: No

GroundWater: No

Pervious Land Use Acres
C D,Urban,Mod(5-10%) 0.079

Pervious Total 0.079

Impervious Land Use Acres

Impervious Total 0

Basin Total 0.079

Element Flows To:

Surface	Interflow	Groundwater
Channel 1	Channel 1	

Routing Elements
Predeveloped Routing

Mitigated Routing

Bio Swale 1

Bottom Length: 285.00 ft.
 Bottom Width: 10.00 ft.
 Material thickness of first layer: 2.25
 Material type for first layer: Loamy fine sand
 Material thickness of second layer: 1
 Material type for second layer: GRAVEL
 Material thickness of third layer: 0
 Material type for third layer: GRAVEL
 Underdrain used
 Underdrain Diameter (ft): 0.5
 Orifice Diameter (in): 6
 Offset (in): 0
 Flow Through Underdrain (ac-ft): 7.6
 Total Outflow (ac-ft): 7.66
 Percent Through Underdrain: 99.22
 Discharge Structure
 Riser Height: 0.5 ft.
 Riser Diameter: 12 in.
 Orifice 1 Diameter: 0.5 in. Elevation:0.083 ft.
 Element Flows To:
 Outlet 1 Outlet 2
 Channel 1

Landscape Swale Hydraulic Table

Stage(ft)	Area(ac)	Volume(ac-ft)	Discharge(cfs)	Infilt(cfs)
82.750	0.0654	0.0000	0.0000	0.0000
82.797	0.0654	0.0012	0.0000	0.0000
82.843	0.0654	0.0023	0.0000	0.0000
82.890	0.0654	0.0035	0.0000	0.0000
82.937	0.0654	0.0046	0.0000	0.0000
82.984	0.0654	0.0058	0.0000	0.0000
83.030	0.0654	0.0069	0.0002	0.0000
83.077	0.0654	0.0081	0.0003	0.0000
83.124	0.0654	0.0093	0.0004	0.0000
83.170	0.0654	0.0104	0.0005	0.0000
83.217	0.0654	0.0116	0.0007	0.0000
83.264	0.0654	0.0127	0.0009	0.0000
83.310	0.0654	0.0139	0.0012	0.0000
83.357	0.0654	0.0151	0.0015	0.0000
83.404	0.0654	0.0162	0.0018	0.0000
83.451	0.0654	0.0174	0.0022	0.0000
83.497	0.0654	0.0185	0.0027	0.0000
83.544	0.0654	0.0197	0.0032	0.0000
83.591	0.0654	0.0208	0.0037	0.0000
83.637	0.0654	0.0220	0.0043	0.0000
83.684	0.0654	0.0232	0.0049	0.0000
83.731	0.0654	0.0243	0.0056	0.0000
83.777	0.0654	0.0255	0.0064	0.0000
83.824	0.0654	0.0266	0.0072	0.0000
83.871	0.0654	0.0278	0.0081	0.0000
83.918	0.0654	0.0290	0.0090	0.0000
83.964	0.0654	0.0301	0.0100	0.0000
84.011	0.0654	0.0313	0.0111	0.0000

84.058	0.0654	0.0324	0.0122	0.0000
84.104	0.0654	0.0336	0.0134	0.0000
84.151	0.0654	0.0347	0.0147	0.0000
84.198	0.0654	0.0359	0.0160	0.0000
84.245	0.0654	0.0371	0.0174	0.0000
84.291	0.0654	0.0382	0.0189	0.0000
84.338	0.0654	0.0394	0.0204	0.0000
84.385	0.0654	0.0405	0.0221	0.0000
84.431	0.0654	0.0417	0.0238	0.0000
84.478	0.0654	0.0428	0.0255	0.0000
84.525	0.0654	0.0440	0.0274	0.0000
84.571	0.0654	0.0452	0.0293	0.0000
84.618	0.0654	0.0463	0.0314	0.0000
84.665	0.0654	0.0475	0.0334	0.0000
84.712	0.0654	0.0486	0.0356	0.0000
84.758	0.0654	0.0498	0.0379	0.0000
84.805	0.0654	0.0510	0.0402	0.0000
84.852	0.0654	0.0521	0.0427	0.0000
84.898	0.0654	0.0533	0.0452	0.0000
84.945	0.0654	0.0544	0.0478	0.0000
84.992	0.0654	0.0556	0.0505	0.0000
85.038	0.0654	0.0568	0.0532	0.0000
85.085	0.0654	0.0580	0.0561	0.0000
85.132	0.0654	0.0593	0.0566	0.0000
85.179	0.0654	0.0605	0.0566	0.0000
85.225	0.0654	0.0617	0.0566	0.0000
85.272	0.0654	0.0629	0.0566	0.0000
85.319	0.0654	0.0641	0.0566	0.0000
85.365	0.0654	0.0654	0.0566	0.0000
85.412	0.0654	0.0666	0.0566	0.0000
85.459	0.0654	0.0678	0.0566	0.0000
85.505	0.0654	0.0690	0.0566	0.0000
85.552	0.0654	0.0703	0.0566	0.0000
85.599	0.0654	0.0715	0.0566	0.0000
85.646	0.0654	0.0727	0.0566	0.0000
85.692	0.0654	0.0739	0.0566	0.0000
85.739	0.0654	0.0751	0.0566	0.0000
85.786	0.0654	0.0764	0.0566	0.0000
85.832	0.0654	0.0776	0.0566	0.0000
85.879	0.0654	0.0788	0.0566	0.0000
85.926	0.0654	0.0800	0.0566	0.0000
85.973	0.0654	0.0813	0.0566	0.0000
86.000	0.0654	0.0820	0.0566	0.0000

Landscape Swale Hydraulic Table

Stage(ft)	Area(ac)	Volume(ac-ft)	Discharge(cfs)	To Amended(cfs)	Infiltr(cfs)
3.2500	0.0654	0.0820	0.0000	0.0578	0.0000
3.2967	0.0673	0.0851	0.0000	0.0578	0.0000
3.3434	0.0691	0.0883	0.0007	0.0590	0.0000
3.3901	0.0709	0.0915	0.0016	0.0601	0.0000
3.4368	0.0728	0.0949	0.0021	0.0613	0.0000
3.4835	0.0746	0.0983	0.0025	0.0625	0.0000
3.5302	0.0764	0.1019	0.0029	0.0637	0.0000
3.5769	0.0783	0.1055	0.0032	0.0648	0.0000
3.6236	0.0801	0.1092	0.0035	0.0660	0.0000
3.6703	0.0819	0.1129	0.0038	0.0672	0.0000
3.7170	0.0838	0.1168	0.0041	0.0684	0.0000
3.7637	0.0856	0.1208	0.0200	0.0696	0.0000

3.8104	0.0874	0.1248	0.1492	0.0707	0.0000
3.8571	0.0893	0.1289	0.3463	0.0719	0.0000
3.9038	0.0911	0.1331	0.5926	0.0731	0.0000
3.9505	0.0929	0.1374	0.8798	0.0743	0.0000
3.9973	0.0948	0.1418	1.2027	0.0754	0.0000
4.0440	0.0966	0.1463	1.5577	0.0766	0.0000
4.0907	0.0984	0.1508	1.9421	0.0778	0.0000
4.1374	0.1003	0.1555	2.3539	0.0790	0.0000
4.1841	0.1021	0.1602	2.7912	0.0801	0.0000
4.2308	0.1039	0.1650	3.2528	0.0813	0.0000
4.2500	0.1047	0.1670	3.7373	0.0818	0.0000

Surface Bio Swale 1

Element Flows To:

Outlet 1

Channel 1

Outlet 2

Bio Swale 1

Bio Swale 2

Bottom Length: 150.00 ft.
 Bottom Width: 13.00 ft.
 Material thickness of first layer: 2.25
 Material type for first layer: Loamy fine sand
 Material thickness of second layer: 1
 Material type for second layer: GRAVEL
 Material thickness of third layer: 0
 Material type for third layer: GRAVEL
 Underdrain used
 Underdrain Diameter (ft): 0.5
 Orifice Diameter (in): 6
 Offset (in): 0
 Flow Through Underdrain (ac-ft): 13.299
 Total Outflow (ac-ft): 14.719
 Percent Through Underdrain: 90.35
 Discharge Structure
 Riser Height: 0.5 ft.
 Riser Diameter: 12 in.
 Orifice 1 Diameter: 0.5 in. Elevation:0.083 ft.
 Element Flows To:
 Outlet 1 Outlet 2
 Channel 1

Landscape Swale Hydraulic Table

Stage(ft)	Area(ac)	Volume(ac-ft)	Discharge(cfs)	Infilt(cfs)
83.750	0.0448	0.0000	0.0000	0.0000
83.797	0.0448	0.0008	0.0000	0.0000
83.843	0.0448	0.0016	0.0000	0.0000
83.890	0.0448	0.0024	0.0000	0.0000
83.937	0.0448	0.0032	0.0000	0.0000
83.984	0.0448	0.0040	0.0000	0.0000
84.030	0.0448	0.0048	0.0000	0.0000
84.077	0.0448	0.0055	0.0000	0.0000
84.124	0.0448	0.0063	0.0000	0.0000
84.170	0.0448	0.0071	0.0000	0.0000
84.217	0.0448	0.0079	0.0000	0.0000
84.264	0.0448	0.0087	0.0000	0.0000
84.310	0.0448	0.0095	0.0000	0.0000
84.357	0.0448	0.0103	0.0000	0.0000
84.404	0.0448	0.0111	0.0000	0.0000
84.451	0.0448	0.0119	0.0000	0.0000
84.497	0.0448	0.0127	0.0000	0.0000
84.544	0.0448	0.0135	0.0000	0.0000
84.591	0.0448	0.0143	0.0000	0.0000
84.637	0.0448	0.0151	0.0000	0.0000
84.684	0.0448	0.0158	0.0000	0.0000
84.731	0.0448	0.0166	0.0000	0.0000
84.777	0.0448	0.0174	0.0000	0.0000
84.824	0.0448	0.0182	0.0000	0.0000
84.871	0.0448	0.0190	0.0000	0.0000
84.918	0.0448	0.0198	0.0000	0.0000
84.964	0.0448	0.0206	0.0000	0.0000
85.011	0.0448	0.0214	0.0000	0.0000
85.058	0.0448	0.0222	0.0000	0.0000
85.104	0.0448	0.0230	0.0000	0.0000

85.151	0.0448	0.0238	0.0000	0.0000
85.198	0.0448	0.0246	0.0000	0.0000
85.245	0.0448	0.0254	0.0000	0.0000
85.291	0.0448	0.0261	0.0000	0.0000
85.338	0.0448	0.0269	0.0000	0.0000
85.385	0.0448	0.0277	0.0000	0.0000
85.431	0.0448	0.0285	0.0000	0.0000
85.478	0.0448	0.0293	0.0000	0.0000
85.525	0.0448	0.0301	0.0000	0.0000
85.571	0.0448	0.0309	0.0000	0.0000
85.618	0.0448	0.0317	0.0000	0.0000
85.665	0.0448	0.0325	0.0000	0.0000
85.712	0.0448	0.0333	0.0000	0.0000
85.758	0.0448	0.0341	0.0000	0.0000
85.805	0.0448	0.0349	0.0000	0.0000
85.852	0.0448	0.0357	0.0000	0.0000
85.898	0.0448	0.0364	0.0000	0.0000
85.945	0.0448	0.0372	0.0000	0.0000
85.992	0.0448	0.0380	0.0000	0.0000
86.038	0.0448	0.0389	0.0000	0.0000
86.085	0.0448	0.0397	0.0000	0.0000
86.132	0.0448	0.0405	0.0000	0.0000
86.179	0.0448	0.0414	0.0000	0.0000
86.225	0.0448	0.0422	0.0000	0.0000
86.272	0.0448	0.0431	0.0000	0.0000
86.319	0.0448	0.0439	0.0000	0.0000
86.365	0.0448	0.0447	0.0000	0.0000
86.412	0.0448	0.0456	0.0000	0.0000
86.459	0.0448	0.0464	0.0000	0.0000
86.505	0.0448	0.0472	0.0000	0.0000
86.552	0.0448	0.0481	0.0000	0.0000
86.599	0.0448	0.0489	0.0000	0.0000
86.646	0.0448	0.0497	0.0000	0.0000
86.692	0.0448	0.0506	0.0000	0.0000
86.739	0.0448	0.0514	0.0000	0.0000
86.786	0.0448	0.0523	0.0000	0.0000
86.832	0.0448	0.0531	0.0000	0.0000
86.879	0.0448	0.0539	0.0000	0.0000
86.926	0.0448	0.0548	0.0000	0.0000
86.973	0.0448	0.0556	0.0000	0.0000
87.000	0.0448	0.0561	0.0000	0.0000

Landscape Swale Hydraulic Table

Stage(ft)	Area(ac)	Volume(ac-ft)	Discharge(cfs)	To Amended(cfs)	Infiltr(cfs)
3.2500	0.0448	0.0561	0.0000	0.0395	0.0000
3.2967	0.0457	0.0582	0.0000	0.0395	0.0000
3.3434	0.0467	0.0604	0.0000	0.0403	0.0000
3.3901	0.0477	0.0626	0.0000	0.0412	0.0000
3.4368	0.0486	0.0648	0.0000	0.0420	0.0000
3.4835	0.0496	0.0671	0.0000	0.0428	0.0000
3.5302	0.0506	0.0694	0.0001	0.0436	0.0000
3.5769	0.0515	0.0718	0.0002	0.0444	0.0000
3.6236	0.0525	0.0743	0.0003	0.0452	0.0000
3.6703	0.0535	0.0767	0.0004	0.0460	0.0000
3.7170	0.0544	0.0792	0.0005	0.0468	0.0000
3.7637	0.0554	0.0818	0.0006	0.0476	0.0000
3.8104	0.0563	0.0844	0.0008	0.0484	0.0000
3.8571	0.0573	0.0871	0.0010	0.0492	0.0000

3.9038	0.0583	0.0898	0.0013	0.0500	0.0000
3.9505	0.0592	0.0925	0.0015	0.0508	0.0000
3.9973	0.0602	0.0953	0.0018	0.0516	0.0000
4.0440	0.0612	0.0981	0.0022	0.0524	0.0000
4.0907	0.0621	0.1010	0.0025	0.0532	0.0000
4.1374	0.0631	0.1039	0.0029	0.0540	0.0000
4.1841	0.0641	0.1069	0.0034	0.0548	0.0000
4.2308	0.0650	0.1099	0.0038	0.0556	0.0000
4.2500	0.0654	0.1112	0.0044	0.0560	0.0000

Surface Bio Swale 2

Element Flows To:

Outlet 1

Channel 1

Outlet 2

Bio Swale 2

Bio Swale 3

Bottom Length: 121.00 ft.
 Bottom Width: 20.00 ft.
 Material thickness of first layer: 2.25
 Material type for first layer: Loamy fine sand
 Material thickness of second layer: 1
 Material type for second layer: GRAVEL
 Material thickness of third layer: 0
 Material type for third layer: GRAVEL
 Underdrain used
 Underdrain Diameter (ft): 0.5
 Orifice Diameter (in): 6
 Offset (in): 0
 Flow Through Underdrain (ac-ft): 7.859
 Total Outflow (ac-ft): 7.917
 Percent Through Underdrain: 99.27
 Discharge Structure
 Riser Height: 0.5 ft.
 Riser Diameter: 12 in.
 Orifice 1 Diameter: 0.5 in. Elevation:0.083 ft.
 Element Flows To:
 Outlet 1 Outlet 2
 Channel 1

Landscape Swale Hydraulic Table

Stage(ft)	Area(ac)	Volume(ac-ft)	Discharge(cfs)	Infilt(cfs)
80.250	0.1097	0.0000	0.0000	0.0000
80.299	0.1091	0.0010	0.0000	0.0000
80.349	0.1083	0.0021	0.0000	0.0000
80.398	0.1075	0.0032	0.0000	0.0000
80.448	0.1067	0.0043	0.0000	0.0000
80.497	0.1058	0.0054	0.0000	0.0000
80.547	0.1050	0.0065	0.0000	0.0000
80.596	0.1042	0.0077	0.0000	0.0000
80.646	0.1034	0.0088	0.0000	0.0000
80.695	0.1025	0.0100	0.0000	0.0000
80.745	0.1017	0.0112	0.0000	0.0000
80.794	0.1009	0.0124	0.0000	0.0000
80.843	0.1001	0.0136	0.0000	0.0000
80.893	0.0992	0.0148	0.0000	0.0000
80.942	0.0984	0.0161	0.0000	0.0000
80.992	0.0976	0.0174	0.0000	0.0000
81.041	0.0968	0.0186	0.0000	0.0000
81.091	0.0959	0.0199	0.0000	0.0000
81.140	0.0951	0.0212	0.0000	0.0000
81.190	0.0943	0.0226	0.0000	0.0000
81.239	0.0935	0.0239	0.0000	0.0000
81.288	0.0926	0.0253	0.0000	0.0000
81.338	0.0918	0.0266	0.0000	0.0000
81.387	0.0910	0.0280	0.0000	0.0000
81.437	0.0902	0.0294	0.0000	0.0000
81.486	0.0893	0.0309	0.0000	0.0000
81.536	0.0885	0.0323	0.0000	0.0000
81.585	0.0877	0.0337	0.0000	0.0000
81.635	0.0869	0.0352	0.0000	0.0000
81.684	0.0861	0.0367	0.0000	0.0000

81.734	0.0852	0.0382	0.0000	0.0000
81.783	0.0844	0.0397	0.0000	0.0000
81.832	0.0836	0.0412	0.0000	0.0000
81.882	0.0828	0.0428	0.0000	0.0000
81.931	0.0819	0.0443	0.0000	0.0000
81.981	0.0811	0.0459	0.0000	0.0000
82.030	0.0803	0.0475	0.0000	0.0000
82.080	0.0795	0.0491	0.0000	0.0000
82.129	0.0786	0.0507	0.0000	0.0000
82.179	0.0778	0.0524	0.0000	0.0000
82.228	0.0770	0.0540	0.0000	0.0000
82.277	0.0762	0.0557	0.0000	0.0000
82.327	0.0753	0.0574	0.0000	0.0000
82.376	0.0745	0.0591	0.0000	0.0000
82.426	0.0737	0.0608	0.0000	0.0000
82.475	0.0729	0.0625	0.0000	0.0000
82.525	0.0720	0.0643	0.0000	0.0000
82.574	0.0712	0.0662	0.0000	0.0000
82.624	0.0704	0.0681	0.0000	0.0000
82.673	0.0696	0.0700	0.0000	0.0000
82.723	0.0687	0.0719	0.0000	0.0000
82.772	0.0679	0.0738	0.0000	0.0000
82.821	0.0671	0.0757	0.0000	0.0000
82.871	0.0663	0.0777	0.0000	0.0000
82.920	0.0654	0.0796	0.0000	0.0000
82.970	0.0646	0.0816	0.0000	0.0000
83.019	0.0638	0.0836	0.0000	0.0000
83.069	0.0630	0.0857	0.0000	0.0000
83.118	0.0621	0.0877	0.0000	0.0000
83.168	0.0613	0.0897	0.0000	0.0000
83.217	0.0605	0.0918	0.0000	0.0000
83.266	0.0597	0.0939	0.0000	0.0000
83.316	0.0589	0.0960	0.0000	0.0000
83.365	0.0580	0.0981	0.0000	0.0000
83.415	0.0572	0.1003	0.0000	0.0000
83.464	0.0564	0.1024	0.0000	0.0000
83.500	0.0556	0.1040	0.0000	0.0000

Landscape Swale Hydraulic Table

Stage(ft)	Area(ac)	Volume(ac-ft)	Discharge(cfs)	To Amended(cfs)	Infiltr(cfs)
3.2500	0.1097	0.1040	0.0000	0.0491	0.0000
3.2995	0.1105	0.1094	0.0000	0.0491	0.0000
3.3489	0.1114	0.1149	0.0000	0.0502	0.0000
3.3984	0.1122	0.1204	0.0000	0.0512	0.0000
3.4478	0.1130	0.1260	0.0000	0.0523	0.0000
3.4973	0.1138	0.1316	0.0000	0.0534	0.0000
3.5467	0.1147	0.1373	0.0002	0.0544	0.0000
3.5962	0.1155	0.1429	0.0003	0.0555	0.0000
3.6456	0.1163	0.1487	0.0004	0.0565	0.0000
3.6951	0.1171	0.1545	0.0005	0.0576	0.0000
3.7445	0.1180	0.1603	0.0007	0.0586	0.0000
3.7940	0.1188	0.1661	0.0009	0.0597	0.0000
3.8434	0.1196	0.1720	0.0012	0.0608	0.0000
3.8929	0.1204	0.1779	0.0015	0.0618	0.0000
3.9423	0.1213	0.1839	0.0018	0.0629	0.0000
3.9918	0.1221	0.1899	0.0022	0.0639	0.0000
4.0412	0.1229	0.1960	0.0026	0.0650	0.0000
4.0907	0.1237	0.2021	0.0031	0.0660	0.0000

4.1401	0.1246	0.2082	0.0036	0.0671	0.0000
4.1896	0.1254	0.2144	0.0042	0.0682	0.0000
4.2390	0.1262	0.2206	0.0048	0.0692	0.0000
4.2885	0.1270	0.2269	0.0055	0.0703	0.0000
4.3379	0.1279	0.2332	0.0062	0.0713	0.0000
4.3874	0.1287	0.2395	0.0070	0.0724	0.0000
4.4368	0.1295	0.2459	0.0079	0.0734	0.0000
4.4863	0.1303	0.2523	0.0088	0.0745	0.0000
4.5000	0.1306	0.2541	0.0098	0.0748	0.0000

Surface Bio Swale 3

Element Flows To:

Outlet 1

Channel 1

Outlet 2

Bio Swale 3

Bio Swale 4

Bottom Length: 150.00 ft.
 Bottom Width: 8.00 ft.
 Material thickness of first layer: 2.25
 Material type for first layer: Loamy fine sand
 Material thickness of second layer: 1
 Material type for second layer: GRAVEL
 Material thickness of third layer: 0
 Material type for third layer: GRAVEL
 Underdrain used
 Underdrain Diameter (ft): 0.5
 Orifice Diameter (in): 0
 Offset (in): 0
 Flow Through Underdrain (ac-ft): 12.215
 Total Outflow (ac-ft): 12.629
 Percent Through Underdrain: 96.72
 Discharge Structure
 Riser Height: 0.5 ft.
 Riser Diameter: 12 in.
 Orifice 1 Diameter: 0.5 in. Elevation:0.083 ft.
 Element Flows To:
 Outlet 1 Outlet 2
 Channel 1

Landscape Swale Hydraulic Table

Stage(ft)	Area(ac)	Volume(ac-ft)	Discharge(cfs)	Infilt(cfs)
83.750	0.0947	0.0000	0.0000	0.0000
83.799	0.0940	0.0005	0.0000	0.0000
83.849	0.0929	0.0011	0.0000	0.0000
83.898	0.0919	0.0016	0.0000	0.0000
83.948	0.0909	0.0022	0.0000	0.0000
83.997	0.0899	0.0028	0.0000	0.0000
84.047	0.0889	0.0034	0.0000	0.0000
84.096	0.0878	0.0041	0.0000	0.0000
84.146	0.0868	0.0047	0.0000	0.0000
84.195	0.0858	0.0054	0.0000	0.0000
84.245	0.0848	0.0061	0.0000	0.0000
84.294	0.0837	0.0068	0.0000	0.0000
84.343	0.0827	0.0076	0.0000	0.0000
84.393	0.0817	0.0083	0.0000	0.0000
84.442	0.0807	0.0091	0.0000	0.0000
84.492	0.0797	0.0099	0.0000	0.0000
84.541	0.0786	0.0107	0.0000	0.0000
84.591	0.0776	0.0115	0.0000	0.0000
84.640	0.0766	0.0124	0.0000	0.0000
84.690	0.0756	0.0133	0.0000	0.0000
84.739	0.0745	0.0142	0.0000	0.0000
84.788	0.0735	0.0151	0.0000	0.0000
84.838	0.0725	0.0160	0.0000	0.0000
84.887	0.0715	0.0169	0.0000	0.0000
84.937	0.0705	0.0179	0.0000	0.0000
84.986	0.0694	0.0189	0.0000	0.0000
85.036	0.0684	0.0199	0.0000	0.0000
85.085	0.0674	0.0209	0.0000	0.0000
85.135	0.0664	0.0220	0.0000	0.0000
85.184	0.0654	0.0230	0.0000	0.0000

85.234	0.0643	0.0241	0.0000	0.0000
85.283	0.0633	0.0252	0.0000	0.0000
85.332	0.0623	0.0263	0.0000	0.0000
85.382	0.0613	0.0275	0.0000	0.0000
85.431	0.0602	0.0286	0.0000	0.0000
85.481	0.0592	0.0298	0.0000	0.0000
85.530	0.0582	0.0310	0.0000	0.0000
85.580	0.0572	0.0322	0.0000	0.0000
85.629	0.0562	0.0334	0.0000	0.0000
85.679	0.0551	0.0347	0.0000	0.0000
85.728	0.0541	0.0360	0.0000	0.0000
85.777	0.0531	0.0373	0.0000	0.0000
85.827	0.0521	0.0386	0.0000	0.0000
85.876	0.0510	0.0399	0.0000	0.0000
85.926	0.0500	0.0413	0.0000	0.0000
85.975	0.0490	0.0426	0.0000	0.0000
86.025	0.0480	0.0441	0.0000	0.0000
86.074	0.0470	0.0456	0.0000	0.0000
86.124	0.0459	0.0471	0.0000	0.0000
86.173	0.0449	0.0486	0.0000	0.0000
86.223	0.0439	0.0501	0.0000	0.0000
86.272	0.0429	0.0517	0.0000	0.0000
86.321	0.0419	0.0533	0.0000	0.0000
86.371	0.0408	0.0549	0.0000	0.0000
86.420	0.0398	0.0565	0.0000	0.0000
86.470	0.0388	0.0582	0.0000	0.0000
86.519	0.0378	0.0598	0.0000	0.0000
86.569	0.0367	0.0615	0.0000	0.0000
86.618	0.0357	0.0632	0.0000	0.0000
86.668	0.0347	0.0650	0.0000	0.0000
86.717	0.0337	0.0667	0.0000	0.0000
86.766	0.0327	0.0685	0.0000	0.0000
86.816	0.0316	0.0703	0.0000	0.0000
86.865	0.0306	0.0721	0.0000	0.0000
86.915	0.0296	0.0739	0.0000	0.0000
86.964	0.0286	0.0758	0.0000	0.0000
87.000	0.0275	0.0771	0.0000	0.0000

Landscape Swale Hydraulic Table

Stage(ft)	Area(ac)	Volume(ac-ft)	Discharge(cfs)	To Amended(cfs)	Infiltr(cfs)
3.2500	0.0947	0.0771	0.0000	0.0244	0.0000
3.2995	0.0957	0.0818	0.0000	0.0244	0.0000
3.3489	0.0967	0.0866	0.0000	0.0249	0.0000
3.3984	0.0978	0.0914	0.0000	0.0254	0.0000
3.4478	0.0988	0.0962	0.0000	0.0259	0.0000
3.4973	0.0998	0.1011	0.0000	0.0265	0.0000
3.5467	0.1008	0.1061	0.0000	0.0270	0.0000
3.5962	0.1018	0.1111	0.0000	0.0275	0.0000
3.6456	0.1029	0.1162	0.0000	0.0280	0.0000
3.6951	0.1039	0.1213	0.0000	0.0286	0.0000
3.7445	0.1049	0.1265	0.0000	0.0291	0.0000
3.7940	0.1059	0.1317	0.0000	0.0296	0.0000
3.8434	0.1070	0.1369	0.0000	0.0301	0.0000
3.8929	0.1080	0.1422	0.0000	0.0307	0.0000
3.9423	0.1090	0.1476	0.0000	0.0312	0.0000
3.9918	0.1100	0.1530	0.0000	0.0317	0.0000
4.0412	0.1110	0.1585	0.0000	0.0322	0.0000
4.0907	0.1121	0.1640	0.0000	0.0327	0.0000

4.1401	0.1131	0.1696	0.0000	0.0333	0.0000
4.1896	0.1141	0.1752	0.0000	0.0338	0.0000
4.2390	0.1151	0.1809	0.0000	0.0343	0.0000
4.2885	0.1162	0.1866	0.0000	0.0348	0.0000
4.3379	0.1172	0.1923	0.0000	0.0354	0.0000
4.3874	0.1182	0.1982	0.0000	0.0359	0.0000
4.4368	0.1192	0.2040	0.0000	0.0364	0.0000
4.4863	0.1202	0.2100	0.0000	0.0369	0.0000
4.5000	0.1205	0.2116	0.0000	0.0371	0.0000

Surface Bio Swale 4

Element Flows To:

Outlet 1

Channel 1

Outlet 2

Bio Swale 4

Channel 1

Bottom Length: 15.00 ft.
 Bottom Width: 10.00 ft.
 Manning's n: 0.03
 Channel bottom slope 1: 0.003 To 1
 Channel Left side slope 0: 5 To 1
 Channel right side slope 2: 5 To 1
 Discharge Structure
 Riser Height: 0 ft.
 Riser Diameter: 0 in.
 Element Flows To:
 Outlet 1 Outlet 2

Channel Hydraulic Table

Stage(ft)	Area(ac)	Volume(ac-ft)	Discharge(cfs)	Infilt(cfs)
0.0000	0.003	0.000	0.000	0.000
0.1111	0.003	0.000	0.711	0.000
0.2222	0.004	0.000	2.307	0.000
0.3333	0.004	0.001	4.637	0.000
0.4444	0.005	0.001	7.667	0.000
0.5556	0.005	0.002	11.39	0.000
0.6667	0.005	0.003	15.81	0.000
0.7778	0.006	0.003	20.96	0.000
0.8889	0.006	0.004	26.83	0.000
1.0000	0.006	0.005	33.46	0.000
1.1111	0.007	0.006	40.86	0.000
1.2222	0.007	0.006	49.06	0.000
1.3333	0.008	0.007	58.08	0.000
1.4444	0.008	0.008	67.93	0.000
1.5556	0.008	0.009	78.66	0.000
1.6667	0.009	0.010	90.27	0.000
1.7778	0.009	0.011	102.8	0.000
1.8889	0.010	0.012	116.2	0.000
2.0000	0.010	0.013	130.6	0.000
2.1111	0.010	0.015	146.0	0.000
2.2222	0.011	0.016	162.4	0.000
2.3333	0.011	0.017	179.8	0.000
2.4444	0.011	0.018	198.3	0.000
2.5556	0.012	0.020	217.9	0.000
2.6667	0.012	0.021	238.5	0.000
2.7778	0.013	0.022	260.2	0.000
2.8889	0.013	0.024	283.1	0.000
3.0000	0.013	0.025	307.2	0.000
3.1111	0.014	0.027	332.4	0.000
3.2222	0.014	0.029	358.8	0.000
3.3333	0.014	0.030	386.4	0.000
3.4444	0.015	0.032	415.3	0.000
3.5556	0.015	0.034	445.4	0.000
3.6667	0.016	0.035	476.9	0.000
3.7778	0.016	0.037	509.6	0.000
3.8889	0.016	0.039	543.6	0.000
4.0000	0.017	0.041	579.0	0.000
4.1111	0.017	0.043	615.8	0.000
4.2222	0.018	0.045	653.9	0.000
4.3333	0.018	0.047	693.5	0.000

4.4444	0.018	0.049	734.4	0.000
4.5556	0.019	0.051	776.8	0.000
4.6667	0.019	0.053	820.7	0.000
4.7778	0.019	0.055	866.0	0.000
4.8889	0.020	0.058	912.9	0.000
5.0000	0.020	0.060	961.2	0.000
5.1111	0.021	0.062	1011.	0.000
5.2222	0.021	0.065	1062.	0.000
5.3333	0.021	0.067	1115.	0.000
5.4444	0.022	0.069	1170.	0.000
5.5556	0.022	0.072	1226.	0.000
5.6667	0.023	0.074	1284.	0.000
5.7778	0.023	0.077	1343.	0.000
5.8889	0.023	0.080	1405.	0.000
6.0000	0.024	0.082	1467.	0.000
6.1111	0.024	0.085	1532.	0.000
6.2222	0.024	0.088	1598.	0.000
6.3333	0.025	0.091	1666.	0.000
6.4444	0.025	0.093	1736.	0.000
6.5556	0.026	0.096	1808.	0.000
6.6667	0.026	0.099	1881.	0.000
6.7778	0.026	0.102	1956.	0.000
6.8889	0.027	0.105	2033.	0.000
7.0000	0.027	0.108	2112.	0.000
7.1111	0.028	0.111	2193.	0.000
7.2222	0.028	0.114	2275.	0.000
7.3333	0.028	0.118	2360.	0.000
7.4444	0.029	0.121	2446.	0.000
7.5556	0.029	0.124	2534.	0.000
7.6667	0.029	0.127	2624.	0.000
7.7778	0.030	0.131	2717.	0.000
7.8889	0.030	0.134	2811.	0.000
8.0000	0.031	0.138	2907.	0.000
8.1111	0.031	0.141	3005.	0.000
8.2222	0.031	0.145	3105.	0.000
8.3333	0.032	0.148	3208.	0.000
8.4444	0.032	0.152	3312.	0.000
8.5556	0.033	0.155	3418.	0.000
8.6667	0.033	0.159	3527.	0.000
8.7778	0.033	0.163	3637.	0.000
8.8889	0.034	0.167	3750.	0.000
9.0000	0.034	0.170	3865.	0.000
9.1111	0.034	0.174	3982.	0.000
9.2222	0.035	0.178	4101.	0.000
9.3333	0.035	0.182	4222.	0.000
9.4444	0.036	0.186	4346.	0.000
9.5556	0.036	0.190	4472.	0.000
9.6667	0.036	0.194	4600.	0.000
9.7778	0.037	0.198	4730.	0.000
9.8889	0.037	0.202	4863.	0.000
10.000	0.038	0.207	4997.	0.000
10.111	0.038	0.211	5134.	0.000

Analysis Results

POC 1

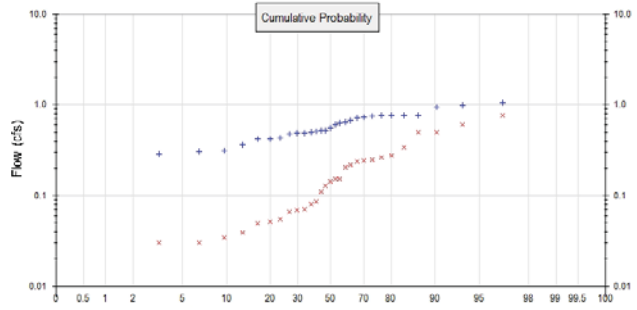
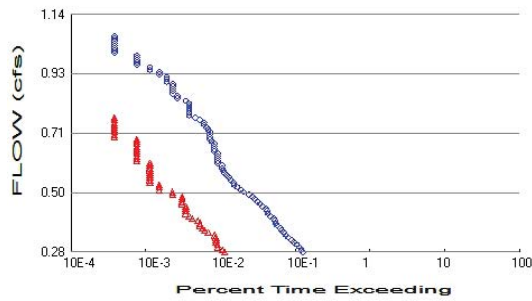

+ Predeveloped x Mitigated

Predeveloped Landuse Totals for POC #1

Total Pervious Area: 1.38
 Total Impervious Area: 1.7

Mitigated Landuse Totals for POC #1

Total Pervious Area: 1.1436
 Total Impervious Area: 1.8816

Flow Frequency Method: Log Pearson Type III 17B

Flow Frequency Return Periods for Predeveloped. POC #1

Return Period	Flow(cfs)
2 year	0.559759
5 year	0.758992
10 year	0.883828
25 year	1.034339

Flow Frequency Return Periods for Mitigated. POC #1

Return Period	Flow(cfs)
2 year	0.125099
5 year	0.28229
10 year	0.431963
25 year	0.67993

Annual Peaks

Annual Peaks for Predeveloped and Mitigated. POC #1

Year	Predeveloped	Mitigated
1979	0.718	0.153
1980	0.994	0.152
1981	0.600	0.143
1982	0.762	0.216
1983	0.741	0.276
1984	0.311	0.049
1985	0.501	0.034
1986	0.674	0.128
1987	0.771	0.497
1988	0.246	0.030
1989	0.424	0.071
1990	0.765	0.086
1991	0.420	0.080
1992	0.494	0.246

1993	0.507	0.241
1994	0.361	0.055
1995	0.749	0.498
1996	0.769	0.341
1997	0.939	0.605
1998	1.064	0.770
1999	0.482	0.070
2000	0.559	0.239
2001	0.642	0.265
2002	0.289	0.026
2003	0.488	0.039
2004	0.520	0.205
2005	0.639	0.110
2006	0.432	0.066
2007	0.519	0.051
2008	0.307	0.030

Ranked Annual Peaks

Ranked Annual Peaks for Predeveloped and Mitigated. POC #1

Rank	Predeveloped	Mitigated
1	1.0639	0.7702
2	0.9942	0.6051
3	0.9393	0.4982
4	0.7706	0.4975
5	0.7687	0.3410
6	0.7646	0.2756
7	0.7617	0.2650
8	0.7491	0.2460
9	0.7407	0.2411
10	0.7177	0.2392
11	0.6737	0.2158
12	0.6424	0.2052
13	0.6389	0.1534
14	0.5996	0.1524
15	0.5587	0.1433
16	0.5205	0.1283
17	0.5192	0.1096
18	0.5065	0.0860
19	0.5012	0.0803
20	0.4941	0.0710
21	0.4878	0.0697
22	0.4816	0.0663
23	0.4323	0.0547
24	0.4244	0.0512
25	0.4201	0.0491
26	0.3615	0.0391
27	0.3108	0.0343
28	0.3069	0.0303
29	0.2887	0.0301
30	0.2458	0.0256

Duration Flows

The Facility PASSED

Flow(cfs)	Predev	Mit	Percentage	Pass/Fail
0.2799	336	30	8	Pass
0.2886	318	28	8	Pass
0.2973	299	24	8	Pass
0.3060	275	24	8	Pass
0.3147	252	23	9	Pass
0.3234	235	23	9	Pass
0.3321	212	23	10	Pass
0.3408	200	22	11	Pass
0.3495	186	18	9	Pass
0.3582	172	16	9	Pass
0.3669	167	15	8	Pass
0.3756	150	14	9	Pass
0.3843	144	14	9	Pass
0.3931	141	13	9	Pass
0.4018	135	11	8	Pass
0.4105	122	10	8	Pass
0.4192	113	9	7	Pass
0.4279	110	9	8	Pass
0.4366	106	9	8	Pass
0.4453	96	9	9	Pass
0.4540	89	8	8	Pass
0.4627	82	8	9	Pass
0.4714	76	8	10	Pass
0.4801	71	8	11	Pass
0.4888	63	6	9	Pass
0.4975	54	6	11	Pass
0.5062	49	4	8	Pass
0.5149	44	4	9	Pass
0.5236	40	4	10	Pass
0.5323	39	3	7	Pass
0.5411	36	3	8	Pass
0.5498	34	3	8	Pass
0.5585	32	3	9	Pass
0.5672	30	3	10	Pass
0.5759	29	3	10	Pass
0.5846	28	3	10	Pass
0.5933	28	3	10	Pass
0.6020	24	3	12	Pass
0.6107	24	2	8	Pass
0.6194	24	2	8	Pass
0.6281	24	2	8	Pass
0.6368	24	2	8	Pass
0.6455	22	2	9	Pass
0.6542	22	2	9	Pass
0.6629	22	2	9	Pass
0.6716	22	2	9	Pass
0.6803	20	2	10	Pass
0.6891	19	2	10	Pass
0.6978	19	1	5	Pass
0.7065	19	1	5	Pass
0.7152	19	1	5	Pass
0.7239	18	1	5	Pass
0.7326	17	1	5	Pass

0.7413	16	1	6	Pass
0.7500	16	1	6	Pass
0.7587	14	1	7	Pass
0.7674	12	1	8	Pass
0.7761	10	0	0	Pass
0.7848	10	0	0	Pass
0.7935	10	0	0	Pass
0.8022	10	0	0	Pass
0.8109	10	0	0	Pass
0.8196	10	0	0	Pass
0.8283	9	0	0	Pass
0.8371	7	0	0	Pass
0.8458	7	0	0	Pass
0.8545	6	0	0	Pass
0.8632	6	0	0	Pass
0.8719	6	0	0	Pass
0.8806	6	0	0	Pass
0.8893	6	0	0	Pass
0.8980	5	0	0	Pass
0.9067	5	0	0	Pass
0.9154	5	0	0	Pass
0.9241	4	0	0	Pass
0.9328	4	0	0	Pass
0.9415	3	0	0	Pass
0.9502	3	0	0	Pass
0.9589	2	0	0	Pass
0.9676	2	0	0	Pass
0.9763	2	0	0	Pass
0.9851	2	0	0	Pass
0.9938	2	0	0	Pass
1.0025	1	0	0	Pass
1.0112	1	0	0	Pass
1.0199	1	0	0	Pass
1.0286	1	0	0	Pass
1.0373	1	0	0	Pass
1.0460	1	0	0	Pass
1.0547	1	0	0	Pass
1.0634	1	0	0	Pass
1.0721	0	0	0	Pass
1.0808	0	0	0	Pass
1.0895	0	0	0	Pass
1.0982	0	0	0	Pass
1.1069	0	0	0	Pass
1.1156	0	0	0	Pass
1.1243	0	0	0	Pass
1.1331	0	0	0	Pass
1.1418	0	0	0	Pass

Water Quality

Drawdown Time Results

Pond: Surface Bio Swale 1

Days	Stage(feet)	Percent of Total Run Time
1	0.980	100.00
2	0.980	100.00
3	0.980	100.00
4	0.980	100.00
5	0.980	100.00

Maximum Stage: 82.80 Drawdown Time: Less than 1 day

Pond: Bio Swale 1

Days	Stage(feet)	Percent of Total Run Time
1	0.341	100.00
2	3.250	100.00
3	3.250	100.00
4	3.250	100.00
5	3.250	100.00

Maximum Stage: 84.41 Drawdown Time: Exceeds 5 days.

Pond: Bio Swale 2

Days	Stage(feet)	Percent of Total Run Time
1	0.386	100.00
2	0.440	100.00
3	0.519	100.00
4	0.648	100.00
5	0.917	100.00

Maximum Stage: 86.64 Drawdown Time: Exceeds 5 days.

Pond: Bio Swale 3

Days	Stage(feet)	Percent of Total Run Time
1	0.381	100.00
2	0.427	100.00
3	0.489	100.00
4	0.578	100.00
5	0.722	100.00

Maximum Stage: 82.77 Drawdown Time: Exceeds 5 days.

Pond: Bio Swale 4

Days	Stage(feet)	Percent of Total Run Time
1	0.000	N/A
2	0.000	N/A
3	0.000	N/A
4	0.000	N/A
5	0.000	N/A

Maximum Stage: 86.87 Drawdown Time: Exceeds 5 days.

Pond: Surface Bio Swale 3

Days	Stage(feet)	Percent of Total Run Time
1	1.000	100.00
2	1.000	100.00
3	1.000	100.00

4	1.000	100.00
5	1.000	100.00

Maximum Stage: 80.59 Drawdown Time: Less than 1 day

Pond: Channel 1

Days	Stage(feet)	Percent of Total Run Time
1	N/A	N/A
2	N/A	N/A
3	N/A	N/A
4	N/A	N/A
5	N/A	N/A

Maximum Stage: 0.226 Drawdown Time: Less than 1 day

POC 2

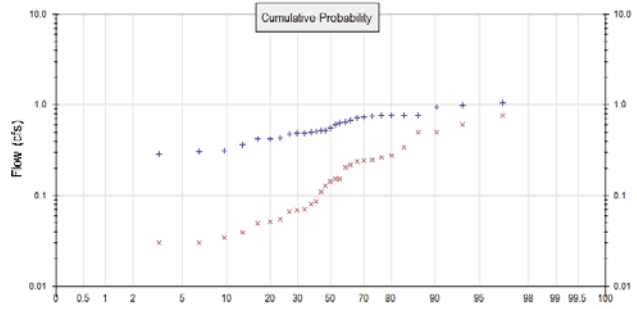
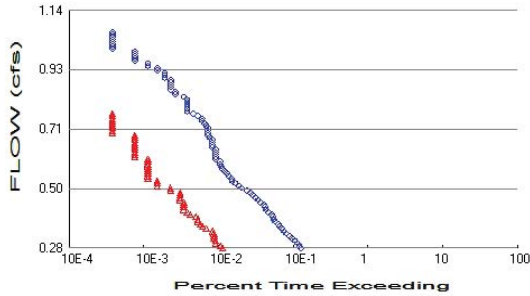

+ Predeveloped x Mitigated

Predeveloped Landuse Totals for POC #2

Total Pervious Area: 0
 Total Impervious Area: 0

Mitigated Landuse Totals for POC #2

Total Pervious Area: 0.226
 Total Impervious Area: 0.39

Flow Frequency Method: Log Pearson Type III 17B

Flow Frequency Return Periods for Predeveloped. POC #2

Return Period	Flow(cfs)
2 year	0
5 year	0
10 year	0
25 year	0

Flow Frequency Return Periods for Mitigated. POC #2

Return Period	Flow(cfs)
2 year	0
5 year	0
10 year	0
25 year	0

Annual Peaks

Annual Peaks for Predeveloped and Mitigated. POC #2

Year	Predeveloped	Mitigated
2 year	0	0
5 year	0	0
10 year	0	0
25 year	0	0

Ranked Annual Peaks

Ranked Annual Peaks for Predeveloped and Mitigated. POC #2

Rank	Predeveloped	Mitigated
1	0	0
2	0	0
3	0	0
4	0	0
5	0	0
6	0	0
7	0	0
8	0	0
9	0	0
10	0	0

Duration Flows
The Facility PASSED

Flow(cfs)	Predev	Mit	Percentage	Pass/Fail
0.0000	0	0	0	Pass
0.0000	0	0	0	Pass
0.0000	0	0	0	Pass
0.0000	0	0	0	Pass
0.0000	0	0	0	Pass
0.0000	0	0	0	Pass
0.0000	0	0	0	Pass
0.0000	0	0	0	Pass
0.0000	0	0	0	Pass
0.0000	0	0	0	Pass
0.0000	0	0	0	Pass
0.0000	0	0	0	Pass
0.0000	0	0	0	Pass
0.0000	0	0	0	Pass
0.0000	0	0	0	Pass
0.0000	0	0	0	Pass
0.0000	0	0	0	Pass
0.0000	0	0	0	Pass
0.0000	0	0	0	Pass
0.0000	0	0	0	Pass
0.0000	0	0	0	Pass
0.0000	0	0	0	Pass
0.0000	0	0	0	Pass
0.0000	0	0	0	Pass
0.0000	0	0	0	Pass
0.0000	0	0	0	Pass
0.0000	0	0	0	Pass
0.0000	0	0	0	Pass
0.0000	0	0	0	Pass
0.0000	0	0	0	Pass
0.0000	0	0	0	Pass
0.0000	0	0	0	Pass
0.0000	0	0	0	Pass
0.0000	0	0	0	Pass
0.0000	0	0	0	Pass
0.0000	0	0	0	Pass
0.0000	0	0	0	Pass
0.0000	0	0	0	Pass
0.0000	0	0	0	Pass
0.0000	0	0	0	Pass
0.0000	0	0	0	Pass
0.0000	0	0	0	Pass
0.0000	0	0	0	Pass
0.0000	0	0	0	Pass
0.0000	0	0	0	Pass
0.0000	0	0	0	Pass
0.0000	0	0	0	Pass
0.0000	0	0	0	Pass
0.0000	0	0	0	Pass

Water Quality

Drawdown Time Results

Pond: Surface Bio Swale 1

Days	Stage(feet)	Percent of Total Run Time
1	0.980	100.00
2	0.980	100.00
3	0.980	100.00
4	0.980	100.00
5	0.980	100.00

Maximum Stage: 82.80 Drawdown Time: Less than 1 day

Pond: Bio Swale 1

Days	Stage(feet)	Percent of Total Run Time
1	0.341	100.00
2	3.250	100.00
3	3.250	100.00
4	3.250	100.00
5	3.250	100.00

Maximum Stage: 84.41 Drawdown Time: Exceeds 5 days.

Pond: Bio Swale 2

Days	Stage(feet)	Percent of Total Run Time
1	0.386	100.00
2	0.440	100.00
3	0.519	100.00
4	0.648	100.00
5	0.917	100.00

Maximum Stage: 86.64 Drawdown Time: Exceeds 5 days.

Pond: Bio Swale 3

Days	Stage(feet)	Percent of Total Run Time
1	0.381	100.00
2	0.427	100.00
3	0.489	100.00
4	0.578	100.00
5	0.722	100.00

Maximum Stage: 82.77 Drawdown Time: Exceeds 5 days.

Pond: Bio Swale 4

Days	Stage(feet)	Percent of Total Run Time
1	0.000	N/A
2	0.000	N/A
3	0.000	N/A
4	0.000	N/A
5	0.000	N/A

Maximum Stage: 86.87 Drawdown Time: Exceeds 5 days.

Pond: Surface Bio Swale 3

Days	Stage(feet)	Percent of Total Run Time
1	1.000	100.00
2	1.000	100.00
3	1.000	100.00

4	1.000	100.00
5	1.000	100.00

Maximum Stage: 80.59 Drawdown Time: Less than 1 day

Pond: Channel 1

Days	Stage(feet)	Percent of Total Run Time
1	N/A	N/A
2	N/A	N/A
3	N/A	N/A
4	N/A	N/A
5	N/A	N/A

Maximum Stage: 0.226 Drawdown Time: Less than 1 day

POC 3

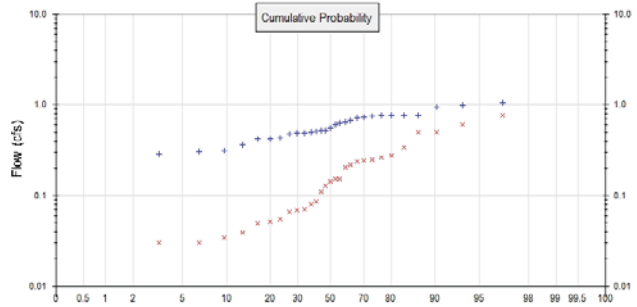

+ Predeveloped x Mitigated

Predeveloped Landuse Totals for POC #3

Total Pervious Area: 0
 Total Impervious Area: 0

Mitigated Landuse Totals for POC #3

Total Pervious Area: 0.334
 Total Impervious Area: 0.666

Flow Frequency Method: Log Pearson Type III 17B

Flow Frequency Return Periods for Predeveloped. POC #3

Return Period	Flow(cfs)
2 year	0
5 year	0
10 year	0
25 year	0

Flow Frequency Return Periods for Mitigated. POC #3

Return Period	Flow(cfs)
2 year	0
5 year	0
10 year	0
25 year	0

Annual Peaks

Annual Peaks for Predeveloped and Mitigated. POC #3

Year	Predeveloped	Mitigated
------	--------------	-----------

Ranked Annual Peaks

Ranked Annual Peaks for Predeveloped and Mitigated. POC #3

Rank	Predeveloped	Mitigated
------	--------------	-----------

Duration Flows

The Facility PASSED

Flow(cfs)	Predev	Mit	Percentage	Pass/Fail
0.0000	0	0	0	Pass
0.0000	0	0	0	Pass
0.0000	0	0	0	Pass
0.0000	0	0	0	Pass
0.0000	0	0	0	Pass
0.0000	0	0	0	Pass
0.0000	0	0	0	Pass
0.0000	0	0	0	Pass
0.0000	0	0	0	Pass
0.0000	0	0	0	Pass
0.0000	0	0	0	Pass
0.0000	0	0	0	Pass
0.0000	0	0	0	Pass
0.0000	0	0	0	Pass
0.0000	0	0	0	Pass
0.0000	0	0	0	Pass
0.0000	0	0	0	Pass
0.0000	0	0	0	Pass
0.0000	0	0	0	Pass
0.0000	0	0	0	Pass
0.0000	0	0	0	Pass
0.0000	0	0	0	Pass
0.0000	0	0	0	Pass
0.0000	0	0	0	Pass
0.0000	0	0	0	Pass
0.0000	0	0	0	Pass
0.0000	0	0	0	Pass
0.0000	0	0	0	Pass
0.0000	0	0	0	Pass
0.0000	0	0	0	Pass
0.0000	0	0	0	Pass
0.0000	0	0	0	Pass
0.0000	0	0	0	Pass
0.0000	0	0	0	Pass
0.0000	0	0	0	Pass
0.0000	0	0	0	Pass
0.0000	0	0	0	Pass
0.0000	0	0	0	Pass
0.0000	0	0	0	Pass
0.0000	0	0	0	Pass
0.0000	0	0	0	Pass
0.0000	0	0	0	Pass
0.0000	0	0	0	Pass
0.0000	0	0	0	Pass
0.0000	0	0	0	Pass
0.0000	0	0	0	Pass
0.0000	0	0	0	Pass
0.0000	0	0	0	Pass
0.0000	0	0	0	Pass
0.0000	0	0	0	Pass
0.0000	0	0	0	Pass
0.0000	0	0	0	Pass
0.0000	0	0	0	Pass

0.0000	0	0	0	Pass
0.0000	0	0	0	Pass
0.0000	0	0	0	Pass
0.0000	0	0	0	Pass
0.0000	0	0	0	Pass
0.0000	0	0	0	Pass
0.0000	0	0	0	Pass
0.0000	0	0	0	Pass
0.0000	0	0	0	Pass
0.0000	0	0	0	Pass
0.0000	0	0	0	Pass
0.0000	0	0	0	Pass
0.0000	0	0	0	Pass
0.0000	0	0	0	Pass
0.0000	0	0	0	Pass
0.0000	0	0	0	Pass
0.0000	0	0	0	Pass
0.0000	0	0	0	Pass
0.0000	0	0	0	Pass
0.0000	0	0	0	Pass
0.0000	0	0	0	Pass
0.0000	0	0	0	Pass
0.0000	0	0	0	Pass
0.0000	0	0	0	Pass
0.0000	0	0	0	Pass
0.0000	0	0	0	Pass
0.0000	0	0	0	Pass
0.0000	0	0	0	Pass
0.0000	0	0	0	Pass
0.0000	0	0	0	Pass
0.0000	0	0	0	Pass
0.0000	0	0	0	Pass
0.0000	0	0	0	Pass
0.0000	0	0	0	Pass
0.0000	0	0	0	Pass
0.0000	0	0	0	Pass
0.0000	0	0	0	Pass
0.0000	0	0	0	Pass
0.0000	0	0	0	Pass
0.0000	0	0	0	Pass

Water Quality

Drawdown Time Results

Pond: Surface Bio Swale 1

Days	Stage(feet)	Percent of Total Run Time
1	0.980	100.00
2	0.980	100.00
3	0.980	100.00
4	0.980	100.00
5	0.980	100.00

Maximum Stage: 82.80 Drawdown Time: Less than 1 day

Pond: Bio Swale 1

Days	Stage(feet)	Percent of Total Run Time
1	0.341	100.00
2	3.250	100.00
3	3.250	100.00
4	3.250	100.00
5	3.250	100.00

Maximum Stage: 84.41 Drawdown Time: Exceeds 5 days.

Pond: Bio Swale 2

Days	Stage(feet)	Percent of Total Run Time
1	0.386	100.00
2	0.440	100.00
3	0.519	100.00
4	0.648	100.00
5	0.917	100.00

Maximum Stage: 86.64 Drawdown Time: Exceeds 5 days.

Pond: Bio Swale 3

Days	Stage(feet)	Percent of Total Run Time
1	0.381	100.00
2	0.427	100.00
3	0.489	100.00
4	0.578	100.00
5	0.722	100.00

Maximum Stage: 82.77 Drawdown Time: Exceeds 5 days.

Pond: Bio Swale 4

Days	Stage(feet)	Percent of Total Run Time
1	0.000	N/A
2	0.000	N/A
3	0.000	N/A
4	0.000	N/A
5	0.000	N/A

Maximum Stage: 86.87 Drawdown Time: Exceeds 5 days.

Pond: Surface Bio Swale 3

Days	Stage(feet)	Percent of Total Run Time
1	1.000	100.00
2	1.000	100.00
3	1.000	100.00

4	1.000	100.00
5	1.000	100.00

Maximum Stage: 80.59 Drawdown Time: Less than 1 day

Pond: Channel 1

Days	Stage(feet)	Percent of Total Run Time
1	N/A	N/A
2	N/A	N/A
3	N/A	N/A
4	N/A	N/A
5	N/A	N/A

Maximum Stage: 0.226 Drawdown Time: Less than 1 day

POC 4

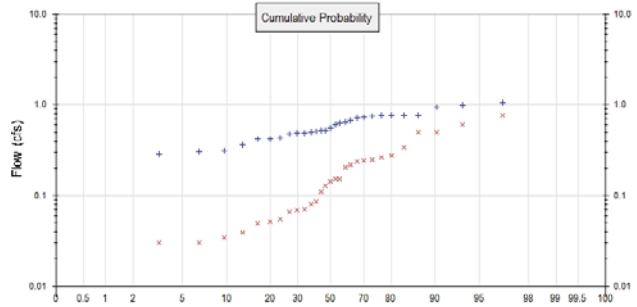

+ Predeveloped x Mitigated

Predeveloped Landuse Totals for POC #4

Total Pervious Area: 0
 Total Impervious Area: 0

Mitigated Landuse Totals for POC #4

Total Pervious Area: 0.1666
 Total Impervious Area: 0.421

Flow Frequency Method: Log Pearson Type III 17B

Flow Frequency Return Periods for Predeveloped. POC #4

Return Period	Flow(cfs)
2 year	0
5 year	0
10 year	0
25 year	0

Flow Frequency Return Periods for Mitigated. POC #4

Return Period	Flow(cfs)
2 year	0
5 year	0
10 year	0
25 year	0

Annual Peaks

Annual Peaks for Predeveloped and Mitigated. POC #4

Year	Predeveloped	Mitigated
------	--------------	-----------

Ranked Annual Peaks

Ranked Annual Peaks for Predeveloped and Mitigated. POC #4

Rank	Predeveloped	Mitigated
------	--------------	-----------

0.0000	0	0	0	Pass
0.0000	0	0	0	Pass
0.0000	0	0	0	Pass
0.0000	0	0	0	Pass
0.0000	0	0	0	Pass
0.0000	0	0	0	Pass
0.0000	0	0	0	Pass
0.0000	0	0	0	Pass
0.0000	0	0	0	Pass
0.0000	0	0	0	Pass
0.0000	0	0	0	Pass
0.0000	0	0	0	Pass
0.0000	0	0	0	Pass
0.0000	0	0	0	Pass
0.0000	0	0	0	Pass
0.0000	0	0	0	Pass
0.0000	0	0	0	Pass
0.0000	0	0	0	Pass
0.0000	0	0	0	Pass
0.0000	0	0	0	Pass
0.0000	0	0	0	Pass
0.0000	0	0	0	Pass
0.0000	0	0	0	Pass
0.0000	0	0	0	Pass
0.0000	0	0	0	Pass
0.0000	0	0	0	Pass
0.0000	0	0	0	Pass
0.0000	0	0	0	Pass
0.0000	0	0	0	Pass
0.0000	0	0	0	Pass
0.0000	0	0	0	Pass
0.0000	0	0	0	Pass
0.0000	0	0	0	Pass
0.0000	0	0	0	Pass
0.0000	0	0	0	Pass
0.0000	0	0	0	Pass
0.0000	0	0	0	Pass
0.0000	0	0	0	Pass
0.0000	0	0	0	Pass
0.0000	0	0	0	Pass
0.0000	0	0	0	Pass

Water Quality

Drawdown Time Results

Pond: Surface Bio Swale 1

Days	Stage(feet)	Percent of Total Run Time
1	0.980	100.00
2	0.980	100.00
3	0.980	100.00
4	0.980	100.00
5	0.980	100.00

Maximum Stage: 82.80 Drawdown Time: Less than 1 day

Pond: Bio Swale 1

Days	Stage(feet)	Percent of Total Run Time
1	0.341	100.00
2	3.250	100.00
3	3.250	100.00
4	3.250	100.00
5	3.250	100.00

Maximum Stage: 84.41 Drawdown Time: Exceeds 5 days.

Pond: Bio Swale 2

Days	Stage(feet)	Percent of Total Run Time
1	0.386	100.00
2	0.440	100.00
3	0.519	100.00
4	0.648	100.00
5	0.917	100.00

Maximum Stage: 86.64 Drawdown Time: Exceeds 5 days.

Pond: Bio Swale 3

Days	Stage(feet)	Percent of Total Run Time
1	0.381	100.00
2	0.427	100.00
3	0.489	100.00
4	0.578	100.00
5	0.722	100.00

Maximum Stage: 82.77 Drawdown Time: Exceeds 5 days.

Pond: Bio Swale 4

Days	Stage(feet)	Percent of Total Run Time
1	0.000	N/A
2	0.000	N/A
3	0.000	N/A
4	0.000	N/A
5	0.000	N/A

Maximum Stage: 86.87 Drawdown Time: Exceeds 5 days.

Pond: Surface Bio Swale 3

Days	Stage(feet)	Percent of Total Run Time
1	1.000	100.00
2	1.000	100.00
3	1.000	100.00

4	1.000	100.00
5	1.000	100.00

Maximum Stage: 80.59 Drawdown Time: Less than 1 day

Pond: Channel 1

Days	Stage(feet)	Percent of Total Run Time
1	N/A	N/A
2	N/A	N/A
3	N/A	N/A
4	N/A	N/A
5	N/A	N/A

Maximum Stage: 0.226 Drawdown Time: Less than 1 day

POC 5

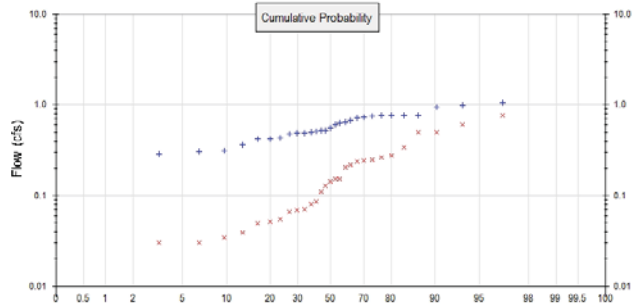

+ Predeveloped x Mitigated

Predeveloped Landuse Totals for POC #5

Total Pervious Area: 0
 Total Impervious Area: 0

Mitigated Landuse Totals for POC #5

Total Pervious Area: 0.189
 Total Impervious Area: 0.395

Flow Frequency Method: Log Pearson Type III 17B

Flow Frequency Return Periods for Predeveloped. POC #5

Return Period	Flow(cfs)
2 year	0
5 year	0
10 year	0
25 year	0

Flow Frequency Return Periods for Mitigated. POC #5

Return Period	Flow(cfs)
2 year	0
5 year	0
10 year	0
25 year	0

Annual Peaks

Annual Peaks for Predeveloped and Mitigated. POC #5

Year	Predeveloped	Mitigated
------	--------------	-----------

Ranked Annual Peaks

Ranked Annual Peaks for Predeveloped and Mitigated. POC #5

Rank	Predeveloped	Mitigated
------	--------------	-----------

Duration Flows
The Facility PASSED

Flow(cfs)	Predev	Mit	Percentage	Pass/Fail
0.0000	0	0	0	Pass
0.0000	0	0	0	Pass
0.0000	0	0	0	Pass
0.0000	0	0	0	Pass
0.0000	0	0	0	Pass
0.0000	0	0	0	Pass
0.0000	0	0	0	Pass
0.0000	0	0	0	Pass
0.0000	0	0	0	Pass
0.0000	0	0	0	Pass
0.0000	0	0	0	Pass
0.0000	0	0	0	Pass
0.0000	0	0	0	Pass
0.0000	0	0	0	Pass
0.0000	0	0	0	Pass
0.0000	0	0	0	Pass
0.0000	0	0	0	Pass
0.0000	0	0	0	Pass
0.0000	0	0	0	Pass
0.0000	0	0	0	Pass
0.0000	0	0	0	Pass
0.0000	0	0	0	Pass
0.0000	0	0	0	Pass
0.0000	0	0	0	Pass
0.0000	0	0	0	Pass
0.0000	0	0	0	Pass
0.0000	0	0	0	Pass
0.0000	0	0	0	Pass
0.0000	0	0	0	Pass
0.0000	0	0	0	Pass
0.0000	0	0	0	Pass
0.0000	0	0	0	Pass
0.0000	0	0	0	Pass
0.0000	0	0	0	Pass
0.0000	0	0	0	Pass
0.0000	0	0	0	Pass
0.0000	0	0	0	Pass
0.0000	0	0	0	Pass
0.0000	0	0	0	Pass
0.0000	0	0	0	Pass
0.0000	0	0	0	Pass
0.0000	0	0	0	Pass
0.0000	0	0	0	Pass
0.0000	0	0	0	Pass
0.0000	0	0	0	Pass
0.0000	0	0	0	Pass
0.0000	0	0	0	Pass
0.0000	0	0	0	Pass
0.0000	0	0	0	Pass
0.0000	0	0	0	Pass
0.0000	0	0	0	Pass
0.0000	0	0	0	Pass
0.0000	0	0	0	Pass

0.0000	0	0	0	Pass
0.0000	0	0	0	Pass
0.0000	0	0	0	Pass
0.0000	0	0	0	Pass
0.0000	0	0	0	Pass
0.0000	0	0	0	Pass
0.0000	0	0	0	Pass
0.0000	0	0	0	Pass
0.0000	0	0	0	Pass
0.0000	0	0	0	Pass
0.0000	0	0	0	Pass
0.0000	0	0	0	Pass
0.0000	0	0	0	Pass
0.0000	0	0	0	Pass
0.0000	0	0	0	Pass
0.0000	0	0	0	Pass
0.0000	0	0	0	Pass
0.0000	0	0	0	Pass
0.0000	0	0	0	Pass
0.0000	0	0	0	Pass
0.0000	0	0	0	Pass
0.0000	0	0	0	Pass
0.0000	0	0	0	Pass
0.0000	0	0	0	Pass
0.0000	0	0	0	Pass
0.0000	0	0	0	Pass
0.0000	0	0	0	Pass
0.0000	0	0	0	Pass
0.0000	0	0	0	Pass
0.0000	0	0	0	Pass
0.0000	0	0	0	Pass
0.0000	0	0	0	Pass
0.0000	0	0	0	Pass
0.0000	0	0	0	Pass
0.0000	0	0	0	Pass
0.0000	0	0	0	Pass
0.0000	0	0	0	Pass
0.0000	0	0	0	Pass
0.0000	0	0	0	Pass

Water Quality

Drawdown Time Results

Pond: Surface Bio Swale 1

Days	Stage(feet)	Percent of Total Run Time
1	0.980	100.00
2	0.980	100.00
3	0.980	100.00
4	0.980	100.00
5	0.980	100.00

Maximum Stage: 82.80 Drawdown Time: Less than 1 day

Pond: Bio Swale 1

Days	Stage(feet)	Percent of Total Run Time
1	0.341	100.00
2	3.250	100.00
3	3.250	100.00
4	3.250	100.00
5	3.250	100.00

Maximum Stage: 84.41 Drawdown Time: Exceeds 5 days.

Pond: Bio Swale 2

Days	Stage(feet)	Percent of Total Run Time
1	0.386	100.00
2	0.440	100.00
3	0.519	100.00
4	0.648	100.00
5	0.917	100.00

Maximum Stage: 86.64 Drawdown Time: Exceeds 5 days.

Pond: Bio Swale 3

Days	Stage(feet)	Percent of Total Run Time
1	0.381	100.00
2	0.427	100.00
3	0.489	100.00
4	0.578	100.00
5	0.722	100.00

Maximum Stage: 82.77 Drawdown Time: Exceeds 5 days.

Pond: Bio Swale 4

Days	Stage(feet)	Percent of Total Run Time
1	0.000	N/A
2	0.000	N/A
3	0.000	N/A
4	0.000	N/A
5	0.000	N/A

Maximum Stage: 86.87 Drawdown Time: Exceeds 5 days.

Pond: Surface Bio Swale 3

Days	Stage(feet)	Percent of Total Run Time
1	1.000	100.00
2	1.000	100.00
3	1.000	100.00

4	1.000	100.00
5	1.000	100.00

Maximum Stage: 80.59 Drawdown Time: Less than 1 day

Pond: Channel 1

Days	Stage(feet)	Percent of Total Run Time
1	N/A	N/A
2	N/A	N/A
3	N/A	N/A
4	N/A	N/A
5	N/A	N/A

Maximum Stage: 0.226 Drawdown Time: Less than 1 day

Model Default Modifications

Total of 0 changes have been made.

PERLND Changes

No PERLND changes have been made.

IMPLND Changes

No IMPLND changes have been made.

Appendix
Predeveloped Schematic



Mitigated Schematic

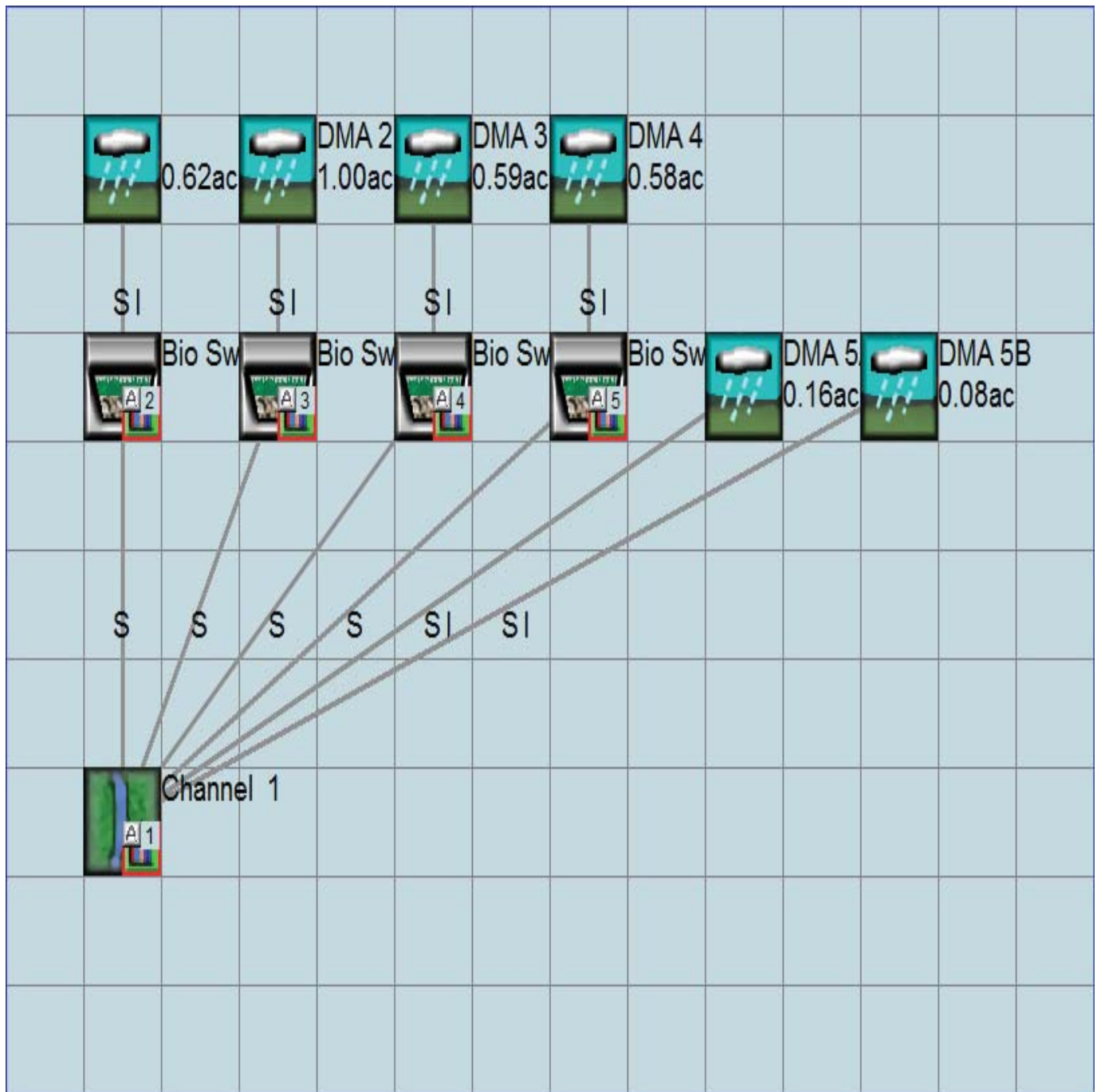

Predeveloped UCI File

RUN

GLOBAL

```
WVHM4 model simulation
START      1978 10 01      END      2008 09 30
RUN INTERP OUTPUT LEVEL  3      0
RESUME     0 RUN          1          UNIT SYSTEM      1
END GLOBAL
```

FILES

```
<File> <Un#> <-----File Name----->***
<-ID->                                     ***
WDM      26      MontereyCountyJailHM1_withOrificeML.wdm
MESSU    25      PreMontereyCountyJailHM1_withOrificeML.MES
          27      PreMontereyCountyJailHM1_withOrificeML.L61
          28      PreMontereyCountyJailHM1_withOrificeML.L62
          30      POCMontereyCountyJailHM1_withOrificeML1.dat
END FILES
```

OPN SEQUENCE

```
INGRP          INDELT 00:60
  PERLND        45
  IMPLND        10
  IMPLND        14
  COPY          501
  DISPLY        1
END INGRP
```

END OPN SEQUENCE

DISPLY

```
DISPLY-INFO1
# - #<-----Title----->***TRAN PIVL DIG1 FIL1  PYR DIG2 FIL2 YRND
1   Basin 1          MAX          1   2   30   9
END DISPLY-INFO1
```

END DISPLY

COPY

```
TIMESERIES
# - # NPT NMN ***
1   1   1   1
501 1   1   1
END TIMESERIES
```

END COPY

GENER

```
OPCODE
#   # OPCD ***
END OPCODE
PARM
#   #           K ***
END PARM
```

END GENER

PERLND

```
GEN-INFO
<PLS ><-----Name----->NBLKS      Unit-systems      Printer ***
# - #      User  t-series  Engl Metr ***
          in  out          ***
45      C/D,Urban,Flat(0-5%)  1   1   1   1   27   0
END GEN-INFO
*** Section PWATER***
```

ACTIVITY

```
<PLS > ***** Active Sections *****
# - # ATMP SNOW PWAT  SED  PST  PWG  PQAL MSTL PEST NITR PHOS TRAC ***
45   0   0   1   0   0   0   0   0   0   0   0   0
END ACTIVITY
```

PRINT-INFO

```
<PLS > ***** Print-flags ***** PIVL  PYR
# - # ATMP SNOW PWAT  SED  PST  PWG  PQAL MSTL PEST NITR PHOS TRAC  *****
45   0   0   4   0   0   0   0   0   0   0   0   0   1   9
```

END PRINT-INFO

PWAT-PARM1

```

<PLS > PWATER variable monthly parameter value flags ***
# - # CSNO RTOP UZFG VCS VUZ VNN VIFW VIRC VLE INFC HWT ***
45 0 0 0 1 0 0 0 0 0 1 0 0

```

END PWAT-PARM1

PWAT-PARM2

```

<PLS > PWATER input info: Part 2 ***
# - # ***FOREST LZSN INFILT LSUR SLSUR KVARY AGWRC
45 0 4.6 0.04 400 0.05 3 0.995

```

END PWAT-PARM2

PWAT-PARM3

```

<PLS > PWATER input info: Part 3 ***
# - # ***PETMAX PETMIN INFEXP INFILD DEEPFR BASETP AGWETP
45 40 35 3 2 0.5 0.15 0

```

END PWAT-PARM3

PWAT-PARM4

```

<PLS > PWATER input info: Part 4 ***
# - # CEPSC UZSN NSUR INTFW IRC LZETP ***
45 0 0.3 0.25 0.8 0.4 0

```

END PWAT-PARM4

MON-LZETPARM

```

<PLS > PWATER input info: Part 3 ***
# - # JAN FEB MAR APR MAY JUN JUL AUG SEP OCT NOV DEC ***
45 0.5 0.5 0.5 0.6 0.65 0.65 0.65 0.65 0.65 0.65 0.55 0.5

```

END MON-LZETPARM

MON-INTERCEP

```

<PLS > PWATER input info: Part 3 ***
# - # JAN FEB MAR APR MAY JUN JUL AUG SEP OCT NOV DEC ***
45 0.11 0.11 0.11 0.11 0.11 0.11 0.11 0.11 0.11 0.11 0.11 0.11

```

END MON-INTERCEP

PWAT-STATE1

```

<PLS > *** Initial conditions at start of simulation
ran from 1990 to end of 1992 (pat 1-11-95) RUN 21 ***
# - # *** CEPS SURS UZS IFWS LZS AGWS GWVS
45 0 0 0.01 0 3.5 1.7 0.1

```

END PWAT-STATE1

END PERLND

IMPLND

GEN-INFO

```

<PLS ><-----Name-----> Unit-systems Printer ***
# - # User t-series Engl Metr ***
in out ***

```

```

10 Sidewalks, Flat (0-5%) 1 1 1 27 0
14 Parking, Flat (0-5%) 1 1 1 27 0

```

END GEN-INFO

*** Section IWATER***

ACTIVITY

```

<PLS > ***** Active Sections *****
# - # ATMP SNOW IWAT SLD IWG IQAL ***
10 0 0 1 0 0 0
14 0 0 1 0 0 0

```

END ACTIVITY

PRINT-INFO

```

<ILS > ***** Print-flags ***** PIVL PYR
# - # ATMP SNOW IWAT SLD IWG IQAL *****
10 0 0 4 0 0 0 1 9
14 0 0 4 0 0 0 1 9

```

END PRINT-INFO

IWAT-PARM1

```

<PLS > IWATER variable monthly parameter value flags ***

```



```

# - # CSNO RTOP VRS VNN RTLI      ***
10      0      0      0      0      0
14      0      0      0      0      0
END IWAT-PARM1

```

```

IWAT-PARM2
<PLS >      IWATER input info: Part 2      ***
# - # *** LSUR      SLSUR      NSUR      RETSC
10      100      0.05      0.1      0.1
14      100      0.05      0.1      0.1
END IWAT-PARM2

```

```

IWAT-PARM3
<PLS >      IWATER input info: Part 3      ***
# - # ***PETMAX      PETMIN
10      0      0
14      0      0
END IWAT-PARM3

```

```

IWAT-STATE1
<PLS > *** Initial conditions at start of simulation
# - # *** RETS      SURS
10      0      0
14      0      0
END IWAT-STATE1

```

END IMPLND

```

SCHEMATIC
<-Source->      <--Area-->      <-Target->      MBLK      ***
<Name> #      <-factor->      <Name> #      Tbl#      ***
Basin 1***
PERLND 45      1.38      COPY 501      12
PERLND 45      1.38      COPY 501      13
IMPLND 10      1.63      COPY 501      15
IMPLND 14      0.07      COPY 501      15

```

*****Routing*****
END SCHEMATIC

```

NETWORK
<-Volume-> <-Grp> <-Member-><--Mult-->Tran <-Target vols> <-Grp> <-Member-> ***
<Name> #      <Name> # #<-factor->strg <Name> # #      <Name> # #      ***
COPY 501 OUTPUT MEAN 1 1 12.1      DISPLY 1      INPUT TIMSER 1

```

```

<-Volume-> <-Grp> <-Member-><--Mult-->Tran <-Target vols> <-Grp> <-Member-> ***
<Name> #      <Name> # #<-factor->strg <Name> # #      <Name> # #      ***
END NETWORK

```

```

RCHRES
GEN-INFO
RCHRES      Name      Nexits      Unit Systems      Printer      ***
# - #<-----><----> User T-series Engl Metr LKFG      ***
in out      ***
END GEN-INFO
*** Section RCHRES***

```

```

ACTIVITY
<PLS > ***** Active Sections *****
# - # HYFG ADFG CNFG HTFG SDFG GQFG OXFG NUFG PKFG PHFG ***
END ACTIVITY

```

```

PRINT-INFO
<PLS > ***** Print-flags ***** PIVL      PYR
# - # HYDR ADCA CONS HEAT SED GQL OXRX NUTR PLNK PHCB PIVL      PYR      *****
END PRINT-INFO

```

HYDR-PARM1

```

RCHRES  Flags for each HYDR Section                                     ***
# - #   VC A1 A2 A3  ODFVFG for each *** ODGTFG for each  FUNCT for each
        FG FG FG FG  possible exit *** possible exit    possible exit
        * * * * *   * * * * *   * * * * *   * * * * *   * * * * *
END HYDR-PARM1

HYDR-PARM2
# - #   FTABNO          LEN          DELTH          STCOR          KS          DB50          ***
<-----><-----><-----><-----><-----><-----><----->          ***
END HYDR-PARM2
HYDR-INIT
RCHRES  Initial conditions for each HYDR section                       ***
# - #   *** VOL      Initial value of COLIND      Initial value of OUTDGT
        *** ac-ft    for each possible exit      for each possible exit
<-----><----->      <-----><-----><-----><----->      *** <-----><-----><-----><----->
END HYDR-INIT
END RCHRES

SPEC-ACTIONS
END SPEC-ACTIONS
FTABLES
END FTABLES

EXT SOURCES
<-Volume-> <Member> SsysSgap<--Mult-->Tran <-Target vols> <-Grp> <-Member-> ***
<Name> # <Name> # tem strg<-factor->strg <Name> # # <Name> # # ***
WDM      2 PREC      ENGL      1          PERLND  1 999 EXTNL  PREC
WDM      2 PREC      ENGL      1          IMPLND  1 999 EXTNL  PREC
WDM      1 EVAP      ENGL      1          PERLND  1 999 EXTNL  PETINP
WDM      1 EVAP      ENGL      1          IMPLND  1 999 EXTNL  PETINP
END EXT SOURCES

EXT TARGETS
<-Volume-> <-Grp> <-Member-><--Mult-->Tran <-Volume-> <Member> Tsys Tgap Amd ***
<Name> # <Name> # #<-factor->strg <Name> # <Name> tem strg strg***
COPY 501 OUTPUT MEAN 1 1 12.1 WDM 501 FLOW ENGL REPL
END EXT TARGETS

MASS-LINK
<Volume> <-Grp> <-Member-><--Mult--> <Target> <-Grp> <-Member->***
<Name> <Name> # #<-factor-> <Name> <Name> # #***
MASS-LINK 12
PERLND PWATER SURO 0.083333 COPY INPUT MEAN
END MASS-LINK 12

MASS-LINK 13
PERLND PWATER IFWO 0.083333 COPY INPUT MEAN
END MASS-LINK 13

MASS-LINK 15
IMPLND IWATER SURO 0.083333 COPY INPUT MEAN
END MASS-LINK 15

END MASS-LINK
END RUN

```

Mitigated UCI File

RUN

GLOBAL

WVHM4 model simulation
START 1978 10 01 END 2008 09 30
RUN INTERP OUTPUT LEVEL 3 0
RESUME 0 RUN 1 UNIT SYSTEM 1
END GLOBAL

FILES

```
<File> <Un#> <-----File Name----->***  
<-ID-> ***  
WDM 26 MontereyCountyJailHM1_withOrificeML.wdm  
MESSU 25 MitMontereyCountyJailHM1_withOrificeML.MES  
27 MitMontereyCountyJailHM1_withOrificeML.L61  
28 MitMontereyCountyJailHM1_withOrificeML.L62  
30 POCMontereyCountyJailHM1_withOrificeML1.dat  
31 POCMontereyCountyJailHM1_withOrificeML2.dat  
32 POCMontereyCountyJailHM1_withOrificeML3.dat  
33 POCMontereyCountyJailHM1_withOrificeML4.dat  
34 POCMontereyCountyJailHM1_withOrificeML5.dat
```

END FILES

OPN SEQUENCE

```
INGRP INDELT 00:60  
PERLND 46  
PERLND 45  
IMPLND 5  
IMPLND 14  
IMPLND 10  
GENER 2  
RCHRES 1  
RCHRES 2  
GENER 4  
RCHRES 3  
RCHRES 4  
GENER 6  
RCHRES 5  
RCHRES 6  
GENER 8  
RCHRES 7  
RCHRES 8  
RCHRES 9  
COPY 2  
COPY 502  
COPY 3  
COPY 503  
COPY 4  
COPY 504  
COPY 5  
COPY 505  
COPY 1  
COPY 501  
DISPLY 2  
DISPLY 3  
DISPLY 4  
DISPLY 5  
DISPLY 1
```

END INGRP

END OPN SEQUENCE

DISPLY

DISPLY-INFO1

```
# - #<-----Title----->***TRAN PIVL DIG1 FIL1 PYR DIG2 FIL2 YRND  
2 Surface Bio Swale 1 MAX 1 2 31 9  
3 Surface Bio Swale 2 MAX 1 2 32 9  
4 Surface Bio Swale 3 MAX 1 2 33 9  
5 Surface Bio Swale 4 MAX 1 2 34 9  
1 Channel 1 MAX 1 2 30 9
```

END DISPLY-INFO1
 END DISPLY
 COPY

TIMESERIES
 # - # NPT NMN ***
 1 1 1
 2 1 1
 502 1 1
 3 1 1
 503 1 1
 4 1 1
 504 1 1
 5 1 1
 505 1 1
 501 1 1
 END TIMESERIES

END COPY
 GENER

OPCODE
 # # OPCD ***
 2 24
 4 24
 6 24
 8 24
 END OPCODE

PARAM
 # # K ***
 2 0.
 4 0.
 6 0.
 8 0.
 END PARAM

END GENER
 PERLND

GEN-INFO
 <PLS ><-----Name----->NBLKS Unit-systems Printer ***
 # - # User t-series Engl Metr ***
 in out ***
 46 C/D,Urban,Mod(5-10%) 1 1 1 1 27 0
 45 C/D,Urban,Flat(0-5%) 1 1 1 1 27 0
 END GEN-INFO
 *** Section PWATER***

ACTIVITY
 <PLS > ***** Active Sections *****
 # - # ATMP SNOW PWAT SED PST PWG PQAL MSTL PEST NITR PHOS TRAC ***
 46 0 0 1 0 0 0 0 0 0 0 0 0
 45 0 0 1 0 0 0 0 0 0 0 0 0
 END ACTIVITY

PRINT-INFO
 <PLS > ***** Print-flags ***** PIVL PYR
 # - # ATMP SNOW PWAT SED PST PWG PQAL MSTL PEST NITR PHOS TRAC *****
 46 0 0 4 0 0 0 0 0 0 0 0 0 1 9
 45 0 0 4 0 0 0 0 0 0 0 0 0 0 1 9
 END PRINT-INFO

PWAT-PARM1
 <PLS > PWATER variable monthly parameter value flags ***
 # - # CSNO RTOP UZFG VCS VUZ VNN VIFW VIRC VLE INFC HWT ***
 46 0 0 0 1 0 0 0 0 1 0 0
 45 0 0 0 1 0 0 0 0 1 0 0
 END PWAT-PARM1

PWAT-PARM2
 <PLS > PWATER input info: Part 2 ***
 # - # ***FOREST LZSN INFILT LSUR SLSUR KVARY AGWRC
 46 0 4.2 0.03 350 0.1 3 0.995
 45 0 4.6 0.04 400 0.05 3 0.995
 END PWAT-PARM2

```

PWAT-PARM3
<PLS > PWATER input info: Part 3 ***
# - # ***PETMAX PETMIN INFEXP INFILD DEEPFR BASETP AGWETP
46 40 35 3 2 0.5 0.15 0
45 40 35 3 2 0.5 0.15 0

```

END PWAT-PARM3

```

PWAT-PARM4
<PLS > PWATER input info: Part 4 ***
# - # CEPSC UZSN NSUR INTFW IRC LZETP ***
46 0 0.28 0.25 0.7 0.35 0
45 0 0.3 0.25 0.8 0.4 0

```

END PWAT-PARM4

```

MON-LZETPARM
<PLS > PWATER input info: Part 3 ***
# - # JAN FEB MAR APR MAY JUN JUL AUG SEP OCT NOV DEC ***
46 0.5 0.5 0.5 0.6 0.65 0.65 0.65 0.65 0.65 0.65 0.55 0.5
45 0.5 0.5 0.5 0.6 0.65 0.65 0.65 0.65 0.65 0.65 0.55 0.5

```

END MON-LZETPARM

```

MON-INTERCEP
<PLS > PWATER input info: Part 3 ***
# - # JAN FEB MAR APR MAY JUN JUL AUG SEP OCT NOV DEC ***
46 0.11 0.11 0.11 0.11 0.11 0.11 0.11 0.11 0.11 0.11 0.11 0.11
45 0.11 0.11 0.11 0.11 0.11 0.11 0.11 0.11 0.11 0.11 0.11 0.11

```

END MON-INTERCEP

```

PWAT-STATE1
<PLS > *** Initial conditions at start of simulation
ran from 1990 to end of 1992 (pat 1-11-95) RUN 21 ***
# - # *** CEPS SURS UZS IFWS LZS AGWS GWVS
46 0 0 0.01 0 3.5 1.7 0.1
45 0 0 0.01 0 3.5 1.7 0.1

```

END PWAT-STATE1

END PERLND

IMPLND

```

GEN-INFO
<PLS ><-----Name-----> Unit-systems Printer ***
# - # User t-series Engr Metr ***
in out ***
5 Roof Area 1 1 1 27 0
14 Parking, Flat (0-5%) 1 1 1 27 0
10 Sidewalks, Flat (0-5%) 1 1 1 27 0

```

END GEN-INFO

*** Section IWATER***

```

ACTIVITY
<PLS > ***** Active Sections *****
# - # ATMP SNOW IWAT SLD IWG IQAL ***
5 0 0 1 0 0 0
14 0 0 1 0 0 0
10 0 0 1 0 0 0

```

END ACTIVITY

```

PRINT-INFO
<ILS > ***** Print-flags ***** PIVL PYR
# - # ATMP SNOW IWAT SLD IWG IQAL *****
5 0 0 4 0 0 0 1 9
14 0 0 4 0 0 0 1 9
10 0 0 4 0 0 0 1 9

```

END PRINT-INFO

```

IWAT-PARM1
<PLS > IWATER variable monthly parameter value flags ***
# - # CSNO RTOP VRS VNN RTLI ***
5 0 0 0 0 0
14 0 0 0 0 0
10 0 0 0 0 0

```

END IWAT-PARM1

```

IWAT-PARM2
<PLS >          IWATER input info: Part 2          ***
# - # ***  L SUR      S L SUR      N SUR      R E T S C
5          100      0.05      0.1      0.1
14         100      0.05      0.1      0.1
10         100      0.05      0.1      0.1
END IWAT-PARM2

```

```

IWAT-PARM3
<PLS >          IWATER input info: Part 3          ***
# - # *** P E T M A X      P E T M I N
5          0          0
14         0          0
10         0          0
END IWAT-PARM3

```

```

IWAT-STATE1
<PLS > *** Initial conditions at start of simulation
# - # ***  R E T S      S U R S
5          0          0
14         0          0
10         0          0
END IWAT-STATE1

```

END IMPLND

```

SCHEMATIC
<-Source->          <--Area-->          <-Target->          MBLK          ***
<Name> #          ***          <-factor-->          <Name> #          Tbl#          ***
PERLND 46          0.203          RCHRES 1          2
PERLND 46          0.203          RCHRES 1          3
PERLND 45          0.023          RCHRES 1          2
PERLND 45          0.023          RCHRES 1          3
IMPLND 5           0.023          RCHRES 1          5
IMPLND 14          0.367          RCHRES 1          5
DMA 4***
PERLND 45          0.189          RCHRES 7          2
PERLND 45          0.189          RCHRES 7          3
IMPLND 5           0.259          RCHRES 7          5
IMPLND 10          0.136          RCHRES 7          5
DMA 2***
PERLND 45          0.046          RCHRES 3          2
PERLND 45          0.046          RCHRES 3          3
PERLND 46          0.288          RCHRES 3          2
PERLND 46          0.288          RCHRES 3          3
IMPLND 5           0.61          RCHRES 3          5
IMPLND 10          0.056          RCHRES 3          5
DMA 3***
PERLND 45          0.0516         RCHRES 5          2
PERLND 45          0.0516         RCHRES 5          3
PERLND 46          0.115          RCHRES 5          2
PERLND 46          0.115          RCHRES 5          3
IMPLND 5           0.379          RCHRES 5          5
IMPLND 10          0.042          RCHRES 5          5
DMA 5A***
PERLND 46          0.149          RCHRES 9          2
PERLND 46          0.149          RCHRES 9          3
IMPLND 10          0.0096         RCHRES 9          5
DMA 5B***
PERLND 46          0.079          RCHRES 9          2
PERLND 46          0.079          RCHRES 9          3

*****Routing*****
PERLND 46          0.203          COPY    2          12
PERLND 45          0.023          COPY    2          12
IMPLND 5           0.023          COPY    2          15
IMPLND 14          0.367          COPY    2          15
PERLND 46          0.203          COPY    2          13

```

PERLND	45	0.023	COPY	2	13
RCHRES	2	1	COPY	1	16
RCHRES	2		RCHRES	9	6
RCHRES	1	1	COPY	1	17
RCHRES	1		RCHRES	9	7
RCHRES	1	1	COPY	2	18
RCHRES	1		RCHRES	2	8
RCHRES	4	1	COPY	1	16
RCHRES	4		RCHRES	9	6
RCHRES	3	1	COPY	1	17
RCHRES	3		RCHRES	9	7
RCHRES	3	1	COPY	3	18
RCHRES	3		RCHRES	4	8
RCHRES	6	1	COPY	1	16
RCHRES	6		RCHRES	9	6
RCHRES	5	1	COPY	1	17
RCHRES	5		RCHRES	9	7
RCHRES	5	1	COPY	4	18
RCHRES	5		RCHRES	6	8
RCHRES	8	1	COPY	1	16
RCHRES	8		RCHRES	9	6
RCHRES	7	1	COPY	1	17
RCHRES	7		RCHRES	9	7
RCHRES	7	1	COPY	5	18
RCHRES	7		RCHRES	8	8
PERLND	45	0.189	COPY	5	12
IMPLND	5	0.259	COPY	5	15
IMPLND	10	0.136	COPY	5	15
PERLND	45	0.189	COPY	5	13
PERLND	45	0.046	COPY	3	12
PERLND	46	0.288	COPY	3	12
IMPLND	5	0.61	COPY	3	15
IMPLND	10	0.056	COPY	3	15
PERLND	45	0.046	COPY	3	13
PERLND	46	0.288	COPY	3	13
PERLND	45	0.0516	COPY	4	12
PERLND	46	0.115	COPY	4	12
IMPLND	5	0.379	COPY	4	15
IMPLND	10	0.042	COPY	4	15
PERLND	45	0.0516	COPY	4	13
PERLND	46	0.115	COPY	4	13
PERLND	46	0.149	COPY	1	12
IMPLND	10	0.0096	COPY	1	15
PERLND	46	0.149	COPY	1	13
PERLND	46	0.079	COPY	1	12
PERLND	46	0.079	COPY	1	13
RCHRES	2	1	COPY	502	16
RCHRES	1	1	COPY	502	17
RCHRES	4	1	COPY	503	16
RCHRES	3	1	COPY	503	17
RCHRES	6	1	COPY	504	16
RCHRES	5	1	COPY	504	17
RCHRES	8	1	COPY	505	16
RCHRES	7	1	COPY	505	17
RCHRES	9	1	COPY	501	16

END SCHEMATIC

NETWORK

<-Volume->	<-Grp>	<-Member->	<--Mult-->	Tran	<-Target vols>	<-Grp>	<-Member->	***				
<Name>	#	<Name>	#	#<-factor->	strg	<Name>	#	#				
COPY	502	OUTPUT	MEAN	1	1	12.1	DISPLY	2	INPUT	TIMSER	1	***
COPY	503	OUTPUT	MEAN	1	1	12.1	DISPLY	3	INPUT	TIMSER	1	***
COPY	504	OUTPUT	MEAN	1	1	12.1	DISPLY	4	INPUT	TIMSER	1	***
COPY	505	OUTPUT	MEAN	1	1	12.1	DISPLY	5	INPUT	TIMSER	1	***
COPY	501	OUTPUT	MEAN	1	1	12.1	DISPLY	1	INPUT	TIMSER	1	***
GENER	2	OUTPUT	TIMSER			.0002778	RCHRES	1	EXTNL	OUTDGT	1	
GENER	4	OUTPUT	TIMSER			.0002778	RCHRES	3	EXTNL	OUTDGT	1	
GENER	6	OUTPUT	TIMSER			.0002778	RCHRES	5	EXTNL	OUTDGT	1	
GENER	8	OUTPUT	TIMSER			.0002778	RCHRES	7	EXTNL	OUTDGT	1	

```

<-Volume-> <-Grp> <-Member-><--Mult-->Tran <-Target vols> <-Grp> <-Member-> ***
<Name> # <Name> # #<-factor->strg <Name> # # <Name> # # ***
END NETWORK

```

RCHRES

GEN-INFO

RCHRES	Name	Nexits	Unit	Systems	Printer				
# - #	<-----><---->	User	T-series	Engl	Metr	LKFG			
			in	out					
1	Surface Bio Swal-008	3	1	1	1	28	0	1	
2	Bio Swale 1	1	1	1	1	28	0	1	
3	Surface Bio Swal-013	3	1	1	1	28	0	1	
4	Bio Swale 2	1	1	1	1	28	0	1	
5	Surface Bio Swal-026	3	1	1	1	28	0	1	
6	Bio Swale 3	1	1	1	1	28	0	1	
7	Surface Bio Swal-029	3	1	1	1	28	0	1	
8	Bio Swale 4	1	1	1	1	28	0	1	
9	Channel 1	1	1	1	1	28	0	1	

END GEN-INFO
 *** Section RCHRES***

ACTIVITY

<PLS > ***** Active Sections *****

# - #	HYFG	ADFG	CNFG	HTFG	SDFG	GQFG	OXFG	NUFG	PKFG	PHFG	***
1	1	0	0	0	0	0	0	0	0	0	
2	1	0	0	0	0	0	0	0	0	0	
3	1	0	0	0	0	0	0	0	0	0	
4	1	0	0	0	0	0	0	0	0	0	
5	1	0	0	0	0	0	0	0	0	0	
6	1	0	0	0	0	0	0	0	0	0	
7	1	0	0	0	0	0	0	0	0	0	
8	1	0	0	0	0	0	0	0	0	0	
9	1	0	0	0	0	0	0	0	0	0	

END ACTIVITY

PRINT-INFO

<PLS > ***** Print-flags ***** PIVL PYR *****

# - #	HYDR	ADCA	CONS	HEAT	SED	GQL	OXRX	NUTR	PLNK	PHCB	PIVL	PYR	*****
1	4	0	0	0	0	0	0	0	0	0	1	9	
2	4	0	0	0	0	0	0	0	0	0	1	9	
3	4	0	0	0	0	0	0	0	0	0	1	9	
4	4	0	0	0	0	0	0	0	0	0	1	9	
5	4	0	0	0	0	0	0	0	0	0	1	9	
6	4	0	0	0	0	0	0	0	0	0	1	9	
7	4	0	0	0	0	0	0	0	0	0	1	9	
8	4	0	0	0	0	0	0	0	0	0	1	9	
9	4	0	0	0	0	0	0	0	0	0	1	9	

END PRINT-INFO

HYDR-PARM1

RCHRES Flags for each HYDR Section *****

# - #	VC	A1	A2	A3	ODFVFG	possible	exit	***	ODGTFG	possible	exit	FUNCT	for each	possible	exit	***			
	FG	FG	FG	FG															
1	0	1	0	0	4	5	6	0	0	0	1	0	0	0	2	1	2	2	2
2	0	1	0	0	4	0	0	0	0	0	0	0	0	0	2	2	2	2	2
3	0	1	0	0	4	5	6	0	0	0	1	0	0	0	2	1	2	2	2
4	0	1	0	0	4	0	0	0	0	0	0	0	0	0	2	2	2	2	2
5	0	1	0	0	4	5	6	0	0	0	1	0	0	0	2	1	2	2	2
6	0	1	0	0	4	0	0	0	0	0	0	0	0	0	2	2	2	2	2
7	0	1	0	0	4	5	6	0	0	0	1	0	0	0	2	1	2	2	2
8	0	1	0	0	4	0	0	0	0	0	0	0	0	0	2	2	2	2	2
9	0	1	0	0	4	0	0	0	0	0	0	0	0	0	2	2	2	2	2

END HYDR-PARM1

HYDR-PARM2

# - #	FTABNO	LEN	DELTH	STCOR	KS	DB50	***
<-----><-----><-----><-----><-----><-----><----->							***

1	1	0.01	0.0	82.75	0.5	0.0
2	2	0.05	0.0	82.75	0.5	0.0
3	3	0.01	0.0	83.75	0.5	0.0
4	4	0.03	0.0	83.75	0.5	0.0
5	5	0.01	0.0	80.25	0.5	0.0
6	6	0.02	0.0	80.25	0.5	0.0
7	7	0.01	0.0	83.75	0.5	0.0
8	8	0.03	0.0	83.75	0.5	0.0
9	9	0.01	0.0	0.0	0.5	0.0

END HYDR-PARM2

HYDR-INIT

RCHRES Initial conditions for each HYDR section ***

#	# *** VOL	Initial value of COLIND	Initial value of OUTDGT
	*** ac-ft	for each possible exit	for each possible exit
<-----><----->		<---><---><---><---><--->	*** <---><---><---><---><--->
1	0	4.0 0.0 6.0 0.0 0.0	0.0 0.0 0.0 0.0 0.0
2	0	4.0 0.0 0.0 0.0 0.0	0.0 0.0 0.0 0.0 0.0
3	0	4.0 0.0 6.0 0.0 0.0	0.0 0.0 0.0 0.0 0.0
4	0	4.0 0.0 0.0 0.0 0.0	0.0 0.0 0.0 0.0 0.0
5	0	4.0 0.0 6.0 0.0 0.0	0.0 0.0 0.0 0.0 0.0
6	0	4.0 0.0 0.0 0.0 0.0	0.0 0.0 0.0 0.0 0.0
7	0	4.0 0.0 6.0 0.0 0.0	0.0 0.0 0.0 0.0 0.0
8	0	4.0 0.0 0.0 0.0 0.0	0.0 0.0 0.0 0.0 0.0
9	0	4.0 0.0 0.0 0.0 0.0	0.0 0.0 0.0 0.0 0.0

END HYDR-INIT

END RCHRES

SPEC-ACTIONS

*** User-Defined Variable Quantity Lines

*** addr <----->

*** kwd	varnam	optyp	opn	vari	s1	s2	s3	tp	multiply	lc	ls	ac	as	agfn	***
<****>	<----->	<----->	<->	<----->	<->	<->	<->	<->	<----->	<><->	<><->	<->	<->	<->	***
UVQUAN	vol2	RCHRES	2	VOL					4						
UVQUAN	v2m2	GLOBAL		WORKSP	1				3						
UVQUAN	vpo2	GLOBAL		WORKSP	2				3						
UVQUAN	v2d2	GENER	2	K	1				3						

*** User-Defined Variable Quantity Lines

*** addr <----->

*** kwd	varnam	optyp	opn	vari	s1	s2	s3	tp	multiply	lc	ls	ac	as	agfn	***
<****>	<----->	<----->	<->	<----->	<->	<->	<->	<->	<----->	<><->	<><->	<->	<->	<->	***
UVQUAN	vol4	RCHRES	4	VOL					4						
UVQUAN	v2m4	GLOBAL		WORKSP	3				3						
UVQUAN	vpo4	GLOBAL		WORKSP	4				3						
UVQUAN	v2d4	GENER	4	K	1				3						

*** User-Defined Variable Quantity Lines

*** addr <----->

*** kwd	varnam	optyp	opn	vari	s1	s2	s3	tp	multiply	lc	ls	ac	as	agfn	***
<****>	<----->	<----->	<->	<----->	<->	<->	<->	<->	<----->	<><->	<><->	<->	<->	<->	***
UVQUAN	vol6	RCHRES	6	VOL					4						
UVQUAN	v2m6	GLOBAL		WORKSP	5				3						
UVQUAN	vpo6	GLOBAL		WORKSP	6				3						
UVQUAN	v2d6	GENER	6	K	1				3						

*** User-Defined Variable Quantity Lines

*** addr <----->

*** kwd	varnam	optyp	opn	vari	s1	s2	s3	tp	multiply	lc	ls	ac	as	agfn	***
<****>	<----->	<----->	<->	<----->	<->	<->	<->	<->	<----->	<><->	<><->	<->	<->	<->	***
UVQUAN	vol8	RCHRES	8	VOL					4						
UVQUAN	v2m8	GLOBAL		WORKSP	7				3						
UVQUAN	vpo8	GLOBAL		WORKSP	8				3						
UVQUAN	v2d8	GENER	8	K	1				3						

*** User-Defined Target Variable Names

*** addr or <-----> addr or <----->

*** kwd	varnam	ct	vari	s1	s2	s3	frac	oper	vari	s1	s2	s3	frac	oper	***
<****>	<----->	<->	<----->	<->	<->	<->	<----->	<->	<----->	<->	<->	<->	<----->	<->	***
UVNAME	v2m2	1	WORKSP	1			1.0	QUAN							

```

UVNAME vpo2      1 WORKSP 2          1.0 QUAN
UVNAME v2d2      1 K          1          1.0 QUAN
*** User-Defined Target Variable Names
***          addr or                      addr or
***          <----->                   <----->
*** kwd  varnam ct  vari  s1 s2 s3  frac oper  vari  s1 s2 s3  frac oper
<****> <-----><-> <-----><-><-><-> <-----> <-> <-----><-><-><-> <-----> <->
UVNAME v2m4      1 WORKSP 3          1.0 QUAN
UVNAME vpo4      1 WORKSP 4          1.0 QUAN
UVNAME v2d4      1 K          1          1.0 QUAN
*** User-Defined Target Variable Names
***          addr or                      addr or
***          <----->                   <----->
*** kwd  varnam ct  vari  s1 s2 s3  frac oper  vari  s1 s2 s3  frac oper
<****> <-----><-> <-----><-><-><-> <-----> <-> <-----><-><-><-> <-----> <->
UVNAME v2m6      1 WORKSP 5          1.0 QUAN
UVNAME vpo6      1 WORKSP 6          1.0 QUAN
UVNAME v2d6      1 K          1          1.0 QUAN
*** User-Defined Target Variable Names
***          addr or                      addr or
***          <----->                   <----->
*** kwd  varnam ct  vari  s1 s2 s3  frac oper  vari  s1 s2 s3  frac oper
<****> <-----><-> <-----><-><-><-> <-----> <-> <-----><-><-><-> <-----> <->
UVNAME v2m8      1 WORKSP 7          1.0 QUAN
UVNAME vpo8      1 WORKSP 8          1.0 QUAN
UVNAME v2d8      1 K          1          1.0 QUAN
*** opt foplop dcdts  yr mo dy hr mn d t  vnam  s1 s2 s3 ac quantity  tc  ts rp
<****><-><-><-><-><-><-> <> <> <> <><><> <-----><-><-><-><-><----->> <> <-><->
GENER  2                                v2m2                                = 3362.
*** Compute remaining available pore space
GENER  2                                vpo2                                = v2m2
GENER  2                                vpo2                                -= vol2
*** Check to see if VPORA goes negative; if so set VPORA = 0.0
IF (vpo2 < 0.0) THEN
GENER  2                                vpo2                                = 0.0
END IF
*** Infiltration volume
GENER  2                                v2d2                                = vpo2
*** opt foplop dcdts  yr mo dy hr mn d t  vnam  s1 s2 s3 ac quantity  tc  ts rp
<****><-><-><-><-><-><-> <> <> <> <><><> <-----><-><-><-><-><----->> <> <-><->
GENER  4                                v2m4                                = 2300.
*** Compute remaining available pore space
GENER  4                                vpo4                                = v2m4
GENER  4                                vpo4                                -= vol4
*** Check to see if VPORA goes negative; if so set VPORA = 0.0
IF (vpo4 < 0.0) THEN
GENER  4                                vpo4                                = 0.0
END IF
*** Infiltration volume
GENER  4                                v2d4                                = vpo4
*** opt foplop dcdts  yr mo dy hr mn d t  vnam  s1 s2 s3 ac quantity  tc  ts rp
<****><-><-><-><-><-><-> <> <> <> <><><> <-----><-><-><-><-><----->> <> <-><->
GENER  6                                v2m6                                = 4237.
*** Compute remaining available pore space
GENER  6                                vpo6                                = v2m6
GENER  6                                vpo6                                -= vol6
*** Check to see if VPORA goes negative; if so set VPORA = 0.0
IF (vpo6 < 0.0) THEN
GENER  6                                vpo6                                = 0.0
END IF
*** Infiltration volume
GENER  6                                v2d6                                = vpo6
*** opt foplop dcdts  yr mo dy hr mn d t  vnam  s1 s2 s3 ac quantity  tc  ts rp
<****><-><-><-><-><-><-> <> <> <> <><><> <-----><-><-><-><-><----->> <> <-><->
GENER  8                                v2m8                                = 3134.
*** Compute remaining available pore space
GENER  8                                vpo8                                = v2m8
GENER  8                                vpo8                                -= vol8
*** Check to see if VPORA goes negative; if so set VPORA = 0.0
IF (vpo8 < 0.0) THEN

```

```

GENER      8                               vpo8           = 0.0
END IF
*** Infiltration volume
GENER      8                               v2d8           = vpo8
END SPEC-ACTIONS

```

```

FTABLES
FTABLE      2
  71      4
  Depth      Area      Volume      Outflowl      Velocity      Travel Time***
  (ft)      (acres)    (acre-ft)    (cfs)         (ft/sec)     (Minutes)***

```

Depth (ft)	Area (acres)	Volume (acre-ft)	Outflowl (cfs)	Velocity (ft/sec)	Travel Time*** (Minutes)***
0.000000	0.065427	0.000000	0.000000		
0.046703	0.065427	0.001158	0.000000		
0.093407	0.065427	0.002316	0.000000		
0.140110	0.065427	0.003474	0.000000		
0.186813	0.065427	0.004632	0.000000		
0.233516	0.065427	0.005790	0.000000		
0.280220	0.065427	0.006949	0.000187		
0.326923	0.065427	0.008107	0.000274		
0.373626	0.065427	0.009265	0.000389		
0.420330	0.065427	0.010423	0.000536		
0.467033	0.065427	0.011581	0.000718		
0.513736	0.065427	0.012739	0.000937		
0.560440	0.065427	0.013897	0.001196		
0.607143	0.065427	0.015055	0.001496		
0.653846	0.065427	0.016213	0.001839		
0.700549	0.065427	0.017371	0.002228		
0.747253	0.065427	0.018530	0.002665		
0.793956	0.065427	0.019688	0.003150		
0.840659	0.065427	0.020846	0.003687		
0.887363	0.065427	0.022004	0.004276		
0.934066	0.065427	0.023162	0.004919		
0.980769	0.065427	0.024320	0.005618		
1.027473	0.065427	0.025478	0.006375		
1.074176	0.065427	0.026636	0.007190		
1.120879	0.065427	0.027794	0.008066		
1.167582	0.065427	0.028952	0.009003		
1.214286	0.065427	0.030110	0.010004		
1.260989	0.065427	0.031269	0.011069		
1.307692	0.065427	0.032427	0.012199		
1.354396	0.065427	0.033585	0.013397		
1.401099	0.065427	0.034743	0.014663		
1.447802	0.065427	0.035901	0.015999		
1.494505	0.065427	0.037059	0.017406		
1.541209	0.065427	0.038217	0.018885		
1.587912	0.065427	0.039375	0.020436		
1.634615	0.065427	0.040533	0.022063		
1.681319	0.065427	0.041691	0.023765		
1.728022	0.065427	0.042849	0.025543		
1.774725	0.065427	0.044008	0.027400		
1.821429	0.065427	0.045166	0.029335		
1.868132	0.065427	0.046324	0.031350		
1.914835	0.065427	0.047482	0.033446		
1.961538	0.065427	0.048640	0.035624		
2.008242	0.065427	0.049798	0.037886		
2.054945	0.065427	0.050956	0.040231		
2.101648	0.065427	0.052114	0.042661		
2.148352	0.065427	0.053272	0.045178		
2.195055	0.065427	0.054430	0.047780		
2.241758	0.065427	0.055589	0.050471		
2.288462	0.065427	0.056811	0.053249		
2.335165	0.065427	0.058033	0.056112		
2.381868	0.065427	0.059255	0.056622		
2.428571	0.065427	0.060478	0.056622		
2.475275	0.065427	0.061700	0.056622		
2.521978	0.065427	0.062922	0.056622		
2.568681	0.065427	0.064144	0.056622		
2.615385	0.065427	0.065367	0.056622		
2.662088	0.065427	0.066589	0.056622		
2.708791	0.065427	0.067811	0.056622		
2.755495	0.065427	0.069033	0.056622		

2.802198 0.065427 0.070256 0.056622
 2.848901 0.065427 0.071478 0.056622
 2.895604 0.065427 0.072700 0.056622
 2.942308 0.065427 0.073922 0.056622
 2.989011 0.065427 0.075145 0.056622
 3.035714 0.065427 0.076367 0.056622
 3.082418 0.065427 0.077589 0.056622
 3.129121 0.065427 0.078811 0.056622
 3.175824 0.065427 0.080034 0.056622
 3.222527 0.065427 0.081256 0.056622
 3.250000 0.065427 0.172147 0.056622

END FTABLE 2

FTABLE 1

23 6

Depth	Area	Volume	Outflow1	Outflow2	outflow 3	Velocity	Travel
Time***	(ft)	(acres)	(acre-ft)	(cfs)	(cfs)	(cfs)	(ft/sec)

(Minutes)***	0.000000	0.065427	0.000000	0.000000	0.056622	0.000000	
	0.046703	0.067260	0.003098	0.000000	0.057797	0.000000	
	0.093407	0.069094	0.006283	0.000670	0.058972	0.000000	
	0.140110	0.070927	0.009552	0.001569	0.060148	0.000000	
	0.186813	0.072761	0.012908	0.002116	0.061323	0.000000	
	0.233516	0.074594	0.016349	0.002547	0.062498	0.000000	
	0.280220	0.076427	0.019875	0.002916	0.063674	0.000000	
	0.326923	0.078261	0.023487	0.003243	0.064849	0.000000	
	0.373626	0.080094	0.027185	0.003540	0.066024	0.000000	
	0.420330	0.081928	0.030969	0.003814	0.067200	0.000000	
	0.467033	0.083761	0.034838	0.004069	0.068375	0.000000	
	0.513736	0.085594	0.038793	0.019988	0.069550	0.000000	
	0.560440	0.087428	0.042833	0.149246	0.070725	0.000000	
	0.607143	0.089261	0.046959	0.346307	0.071901	0.000000	
	0.653846	0.091095	0.051170	0.592646	0.073076	0.000000	
	0.700549	0.092928	0.055468	0.879835	0.074251	0.000000	
	0.747253	0.094761	0.059851	1.202715	0.075427	0.000000	
	0.793956	0.096595	0.064319	1.557702	0.076602	0.000000	
	0.840659	0.098428	0.068873	1.942114	0.077777	0.000000	
	0.887363	0.100261	0.073513	2.353850	0.078953	0.000000	
	0.934066	0.102095	0.078238	2.791203	0.080128	0.000000	
	0.980769	0.103928	0.083049	3.252751	0.081303	0.000000	
	1.000000	0.104683	0.085055	3.737286	0.081787	0.000000	

END FTABLE 1

FTABLE 4

71 4

Depth	Area	Volume	Outflow1	Velocity	Travel Time***
(ft)	(acres)	(acre-ft)	(cfs)	(ft/sec)	(Minutes)***

0.000000	0.044766	0.000000	0.000000		
0.046703	0.044766	0.000792	0.000000		
0.093407	0.044766	0.001585	0.000000		
0.140110	0.044766	0.002377	0.000000		
0.186813	0.044766	0.003170	0.000000		
0.233516	0.044766	0.003962	0.000000		
0.280220	0.044766	0.004754	0.000128		
0.326923	0.044766	0.005547	0.000187		
0.373626	0.044766	0.006339	0.000266		
0.420330	0.044766	0.007131	0.000367		
0.467033	0.044766	0.007924	0.000492		
0.513736	0.044766	0.008716	0.000641		
0.560440	0.044766	0.009509	0.000818		
0.607143	0.044766	0.010301	0.001023		
0.653846	0.044766	0.011093	0.001258		
0.700549	0.044766	0.011886	0.001525		
0.747253	0.044766	0.012678	0.001823		
0.793956	0.044766	0.013470	0.002155		
0.840659	0.044766	0.014263	0.002522		
0.887363	0.044766	0.015055	0.002926		
0.934066	0.044766	0.015848	0.003366		
0.980769	0.044766	0.016640	0.003844		
1.027473	0.044766	0.017432	0.004362		
1.074176	0.044766	0.018225	0.004920		

```

1.120879 0.044766 0.019017 0.005519
1.167582 0.044766 0.019809 0.006160
1.214286 0.044766 0.020602 0.006845
1.260989 0.044766 0.021394 0.007573
1.307692 0.044766 0.022187 0.008347
1.354396 0.044766 0.022979 0.009167
1.401099 0.044766 0.023771 0.010033
1.447802 0.044766 0.024564 0.010947
1.494505 0.044766 0.025356 0.011909
1.541209 0.044766 0.026149 0.012921
1.587912 0.044766 0.026941 0.013983
1.634615 0.044766 0.027733 0.015096
1.681319 0.044766 0.028526 0.016260
1.728022 0.044766 0.029318 0.017477
1.774725 0.044766 0.030110 0.018747
1.821429 0.044766 0.030903 0.020071
1.868132 0.044766 0.031695 0.021450
1.914835 0.044766 0.032488 0.022884
1.961538 0.044766 0.033280 0.024375
2.008242 0.044766 0.034072 0.025922
2.054945 0.044766 0.034865 0.027527
2.101648 0.044766 0.035657 0.029189
2.148352 0.044766 0.036449 0.030911
2.195055 0.044766 0.037242 0.032692
2.241758 0.044766 0.038034 0.034533
2.288462 0.044766 0.038871 0.036433
2.335165 0.044766 0.039707 0.038392
2.381868 0.044766 0.040543 0.038741
2.428571 0.044766 0.041379 0.038741
2.475275 0.044766 0.042216 0.038741
2.521978 0.044766 0.043052 0.038741
2.568681 0.044766 0.043888 0.038741
2.615385 0.044766 0.044725 0.038741
2.662088 0.044766 0.045561 0.038741
2.708791 0.044766 0.046397 0.038741
2.755495 0.044766 0.047233 0.038741
2.802198 0.044766 0.048070 0.038741
2.848901 0.044766 0.048906 0.038741
2.895604 0.044766 0.049742 0.038741
2.942308 0.044766 0.050579 0.038741
2.989011 0.044766 0.051415 0.038741
3.035714 0.044766 0.052251 0.038741
3.082418 0.044766 0.053087 0.038741
3.129121 0.044766 0.053924 0.038741
3.175824 0.044766 0.054760 0.038741
3.222527 0.044766 0.055596 0.038741
3.250000 0.044766 0.117785 0.038741

```

```

END FTABLE 4
FTABLE 3
23 6

```

Depth Time*** (ft) (Minutes)***	Area (acres)	Volume (acre-ft)	Outflow1 (cfs)	Outflow2 (cfs)	outflow 3 (cfs)	Velocity (ft/sec)	Travel
0.000000	0.044766	0.000000	0.000000	0.038741	0.000000		
0.046703	0.045731	0.002113	0.000000	0.039545	0.000000		
0.093407	0.046696	0.004272	0.000670	0.040350	0.000000		
0.140110	0.047661	0.006475	0.001569	0.041154	0.000000		
0.186813	0.048626	0.008723	0.002116	0.041958	0.000000		
0.233516	0.049591	0.011017	0.002547	0.042762	0.000000		
0.280220	0.050556	0.013355	0.002916	0.043566	0.000000		
0.326923	0.051520	0.015739	0.003243	0.044370	0.000000		
0.373626	0.052485	0.018168	0.003540	0.045175	0.000000		
0.420330	0.053450	0.020642	0.003814	0.045979	0.000000		
0.467033	0.054415	0.023160	0.004069	0.046783	0.000000		
0.513736	0.055380	0.025724	0.019988	0.047587	0.000000		
0.560440	0.056345	0.028333	0.149246	0.048391	0.000000		
0.607143	0.057310	0.030987	0.346307	0.049195	0.000000		
0.653846	0.058275	0.033686	0.592646	0.049999	0.000000		
0.700549	0.059240	0.036431	0.879835	0.050804	0.000000		

0.747253	0.060205	0.039220	1.202715	0.051608	0.000000
0.793956	0.061170	0.042054	1.557702	0.052412	0.000000
0.840659	0.062135	0.044934	1.942114	0.053216	0.000000
0.887363	0.063100	0.047858	2.353850	0.054020	0.000000
0.934066	0.064065	0.050827	2.791203	0.054824	0.000000
0.980769	0.065030	0.053842	3.252751	0.055629	0.000000
1.000000	0.065427	0.055096	3.737286	0.055960	0.000000

END FTABLE 3

FTABLE 6

67 4

Depth (ft)	Area (acres)	Volume (acre-ft)	Outflow1 (cfs)	Velocity (ft/sec)	Travel Time*** (Minutes)***
0.000000	0.109722	0.000000	0.000000		
0.049451	0.109127	0.001049	0.000000		
0.098901	0.108303	0.002113	0.000000		
0.148352	0.107479	0.003193	0.000000		
0.197802	0.106654	0.004288	0.000000		
0.247253	0.105830	0.005399	0.000000		
0.296703	0.105006	0.006525	0.000174		
0.346154	0.104182	0.007667	0.000258		
0.395604	0.103358	0.008824	0.000371		
0.445055	0.102534	0.009996	0.000515		
0.494505	0.101709	0.011184	0.000693		
0.543956	0.100885	0.012388	0.000908		
0.593407	0.100061	0.013607	0.001161		
0.642857	0.099237	0.014841	0.001454		
0.692308	0.098413	0.016091	0.001791		
0.741758	0.097589	0.017356	0.002172		
0.791209	0.096764	0.018636	0.002599		
0.840659	0.095940	0.019933	0.003075		
0.890110	0.095116	0.021244	0.003600		
0.939560	0.094292	0.022571	0.004177		
0.989011	0.093468	0.023913	0.004807		
1.038462	0.092643	0.025271	0.005492		
1.087912	0.091819	0.026645	0.006233		
1.137363	0.090995	0.028033	0.007031		
1.186813	0.090171	0.029438	0.007889		
1.236264	0.089347	0.030857	0.008807		
1.285714	0.088523	0.032292	0.009787		
1.335165	0.087698	0.033743	0.010830		
1.384615	0.086874	0.035209	0.011938		
1.434066	0.086050	0.036690	0.013111		
1.483516	0.085226	0.038187	0.014351		
1.532967	0.084402	0.039700	0.015660		
1.582418	0.083578	0.041227	0.017037		
1.631868	0.082753	0.042771	0.018486		
1.681319	0.081929	0.044329	0.020006		
1.730769	0.081105	0.045903	0.021599		
1.780220	0.080281	0.047493	0.023266		
1.829670	0.079457	0.049098	0.025008		
1.879121	0.078632	0.050718	0.026826		
1.928571	0.077808	0.052354	0.028721		
1.978022	0.076984	0.054006	0.030695		
2.027473	0.076160	0.055672	0.032748		
2.076923	0.075336	0.057355	0.034881		
2.126374	0.074512	0.059052	0.037096		
2.175824	0.073687	0.060765	0.039392		
2.225275	0.072863	0.062494	0.041772		
2.274725	0.072039	0.064335	0.044234		
2.324176	0.071215	0.066192	0.046780		
2.373626	0.070391	0.068065	0.048079		
2.423077	0.069567	0.069954	0.048079		
2.472527	0.068742	0.071860	0.048079		
2.521978	0.067918	0.073782	0.048079		
2.571429	0.067094	0.075721	0.048079		
2.620879	0.066270	0.077676	0.048079		
2.670330	0.065446	0.079647	0.048079		
2.719780	0.064621	0.081634	0.048079		
2.769231	0.063797	0.083638	0.048079		
2.818681	0.062973	0.085658	0.048079		

2.868132 0.062149 0.087694 0.048079
 2.917582 0.061325 0.089747 0.048079
 2.967033 0.060501 0.091816 0.048079
 3.016484 0.059676 0.093901 0.048079
 3.065934 0.058852 0.096002 0.048079
 3.115385 0.058028 0.098120 0.048079
 3.164835 0.057204 0.100254 0.048079
 3.214286 0.056380 0.102405 0.048079
 3.250000 0.055556 0.218332 0.048079

END FTABLE 6
 FTABLE 5

27 Time*** (Minutes)***	6 Depth (ft)	Area (acres)	Volume (acre-ft)	Outflow1 (cfs)	Outflow2 (cfs)	outflow 3 (cfs)	Velocity (ft/sec)	Travel
0.000000	0.055556	0.000000	0.000000	0.000000	0.048079	0.000000		
0.049451	0.110546	0.005446	0.000000	0.000000	0.049136	0.000000		
0.098901	0.111371	0.010933	0.000828	0.000828	0.050192	0.000000		
0.148352	0.112195	0.016461	0.001679	0.001679	0.051249	0.000000		
0.197802	0.113019	0.022029	0.002225	0.002225	0.052306	0.000000		
0.247253	0.113843	0.027639	0.002661	0.002661	0.053362	0.000000		
0.296703	0.114667	0.033289	0.003035	0.003035	0.054419	0.000000		
0.346154	0.115491	0.038979	0.003368	0.003368	0.055476	0.000000		
0.395604	0.116316	0.044711	0.003671	0.003671	0.056532	0.000000		
0.445055	0.117140	0.050483	0.003951	0.003951	0.057589	0.000000		
0.494505	0.117964	0.056296	0.004212	0.004212	0.058646	0.000000		
0.543956	0.118788	0.062150	0.004209	0.004209	0.059702	0.000000		
0.593407	0.119612	0.068044	0.0042714	0.0042714	0.060759	0.000000		
0.642857	0.120437	0.073980	0.0042769	0.0042769	0.061816	0.000000		
0.692308	0.121261	0.079956	0.0042440	0.0042440	0.062872	0.000000		
0.741758	0.122085	0.085972	1.163003	0.063929	0.063929	0.000000		
0.791209	0.122909	0.092030	1.535982	0.064986	0.064986	0.000000		
0.840659	0.123733	0.098128	1.942114	0.066042	0.066042	0.000000		
0.890110	0.124557	0.104267	2.378883	0.067099	0.067099	0.000000		
0.939560	0.125382	0.110447	2.844272	0.068156	0.068156	0.000000		
0.989011	0.126206	0.116668	3.336618	0.069213	0.069213	0.000000		
1.038462	0.127030	0.122929	3.854519	0.070269	0.070269	0.000000		
1.087912	0.127854	0.129231	4.396768	0.071326	0.071326	0.000000		
1.137363	0.128678	0.135574	4.962320	0.072383	0.072383	0.000000		
1.186813	0.129502	0.141957	5.550248	0.073439	0.073439	0.000000		
1.236264	0.130327	0.148382	6.159733	0.074496	0.074496	0.000000		
1.250000	0.130556	0.150174	6.790037	0.074789	0.074789	0.000000		

END FTABLE 5
 FTABLE 8

67	4 Depth (ft)	Area (acres)	Volume (acre-ft)	Outflow1 (cfs)	Velocity (ft/sec)	Travel Time*** (Minutes)***
0.000000	0.094697	0.000000	0.000000	0.000000		
0.049451	0.093959	0.000526	0.000000	0.000000		
0.098901	0.092937	0.001071	0.000000	0.000000		
0.148352	0.091916	0.001635	0.000000	0.000000		
0.197802	0.090894	0.002218	0.000000	0.000000		
0.247253	0.089872	0.002821	0.000000	0.000000		
0.296703	0.088851	0.003442	0.000000	0.000000		
0.346154	0.087829	0.004083	0.000000	0.000000		
0.395604	0.086807	0.004743	0.000000	0.000000		
0.445055	0.085785	0.005422	0.000000	0.000000		
0.494505	0.084764	0.006120	0.000000	0.000000		
0.543956	0.083742	0.006838	0.000000	0.000000		
0.593407	0.082720	0.007574	0.000000	0.000000		
0.642857	0.081699	0.008330	0.000000	0.000000		
0.692308	0.080677	0.009105	0.000000	0.000000		
0.741758	0.079655	0.009899	0.000000	0.000000		
0.791209	0.078633	0.010712	0.000000	0.000000		
0.840659	0.077612	0.011544	0.000000	0.000000		
0.890110	0.076590	0.012396	0.000000	0.000000		
0.939560	0.075568	0.013266	0.000000	0.000000		
0.989011	0.074547	0.014156	0.000000	0.000000		
1.038462	0.073525	0.015065	0.000000	0.000000		

1.087912 0.072503 0.015993 0.000000
 1.137363 0.071482 0.016940 0.000000
 1.186813 0.070460 0.017906 0.000000
 1.236264 0.069438 0.018891 0.000000
 1.285714 0.068416 0.019896 0.000000
 1.335165 0.067395 0.020920 0.000000
 1.384615 0.066373 0.021963 0.000000
 1.434066 0.065351 0.023025 0.000000
 1.483516 0.064330 0.024106 0.000000
 1.532967 0.063308 0.025206 0.000000
 1.582418 0.062286 0.026326 0.000000
 1.631868 0.061264 0.027464 0.000000
 1.681319 0.060243 0.028622 0.000000
 1.730769 0.059221 0.029799 0.000000
 1.780220 0.058199 0.030995 0.000000
 1.829670 0.057178 0.032210 0.000000
 1.879121 0.056156 0.033445 0.000000
 1.928571 0.055134 0.034698 0.000000
 1.978022 0.054113 0.035971 0.000000
 2.027473 0.053091 0.037263 0.000000
 2.076923 0.052069 0.038574 0.000000
 2.126374 0.051047 0.039904 0.000000
 2.175824 0.050026 0.041253 0.000000
 2.225275 0.049004 0.042622 0.000000
 2.274725 0.047982 0.044086 0.000000
 2.324176 0.046961 0.045571 0.000000
 2.373626 0.045939 0.047075 0.000000
 2.423077 0.044917 0.048601 0.000000
 2.472527 0.043895 0.050146 0.000000
 2.521978 0.042874 0.051711 0.000000
 2.571429 0.041852 0.053297 0.000000
 2.620879 0.040830 0.054903 0.000000
 2.670330 0.039809 0.056529 0.000000
 2.719780 0.038787 0.058175 0.000000
 2.769231 0.037765 0.059842 0.000000
 2.818681 0.036744 0.061529 0.000000
 2.868132 0.035722 0.063236 0.000000
 2.917582 0.034700 0.064963 0.000000
 2.967033 0.033678 0.066710 0.000000
 3.016484 0.032657 0.068478 0.000000
 3.065934 0.031635 0.070266 0.000000
 3.115385 0.030613 0.072074 0.000000
 3.164835 0.029592 0.073902 0.000000
 3.214286 0.028570 0.075750 0.000000
 3.250000 0.027548 0.161905 0.000000

END FTABLE 8
 FTABLE 7

Time***	Depth (ft)	Area (acres)	Volume (acre-ft)	Outflow1 (cfs)	Outflow2 (cfs)	outflow 3 (cfs)	Velocity (ft/sec)	Travel
(Minutes)***								
0.000000	0.027548	0.000000	0.000000	0.000000	0.000000	0.000000		
0.049451	0.095719	0.004708	0.000000	0.000000	0.024365	0.000000		
0.098901	0.096740	0.009467	0.000828	0.000828	0.024889	0.000000		
0.148352	0.097762	0.014276	0.001679	0.001679	0.025413	0.000000		
0.197802	0.098784	0.019135	0.002225	0.002225	0.025937	0.000000		
0.247253	0.099805	0.024046	0.002661	0.002661	0.026461	0.000000		
0.296703	0.100827	0.029006	0.003035	0.003035	0.026985	0.000000		
0.346154	0.101849	0.034018	0.003368	0.003368	0.027509	0.000000		
0.395604	0.102871	0.039079	0.003671	0.003671	0.028033	0.000000		
0.445055	0.103892	0.044192	0.003951	0.003951	0.028557	0.000000		
0.494505	0.104914	0.049354	0.004212	0.004212	0.029081	0.000000		
0.543956	0.105936	0.054568	0.004209	0.004209	0.029604	0.000000		
0.593407	0.106957	0.059832	0.282714	0.282714	0.030128	0.000000		
0.642857	0.107979	0.065146	0.530769	0.530769	0.030652	0.000000		
0.692308	0.109001	0.070511	0.826440	0.826440	0.031176	0.000000		
0.741758	0.110023	0.075926	1.163003	1.163003	0.031700	0.000000		
0.791209	0.111044	0.081392	1.535982	1.535982	0.032224	0.000000		
0.840659	0.112066	0.086909	1.942114	1.942114	0.032748	0.000000		

0.890110	0.113088	0.092476	2.378883	0.033272	0.000000
0.939560	0.114109	0.098093	2.844272	0.033796	0.000000
0.989011	0.115131	0.103761	3.336618	0.034320	0.000000
1.038462	0.116153	0.109480	3.854519	0.034844	0.000000
1.087912	0.117174	0.115249	4.396768	0.035368	0.000000
1.137363	0.118196	0.121068	4.962320	0.035892	0.000000
1.186813	0.119218	0.126938	5.550248	0.036416	0.000000
1.236264	0.120240	0.132859	6.159733	0.036940	0.000000
1.250000	0.120523	0.134513	6.790037	0.037086	0.000000

END FTABLE 7

FTABLE 9

91 4

Depth (ft)	Area (acres)	Volume (acre-ft)	Outflow1 (cfs)	Velocity (ft/sec)	Travel Time*** (Minutes)***
0.000000	0.003444	0.000000	0.000000		
0.111111	0.003826	0.000404	0.711670		
0.222222	0.004209	0.000850	2.307065		
0.333333	0.004592	0.001339	4.637449		
0.444444	0.004975	0.001871	7.667944		
0.555556	0.005358	0.002445	11.39286		
0.666667	0.005741	0.003061	15.81932		
0.777778	0.006124	0.003720	20.96113		
0.888889	0.006507	0.004422	26.83590		
1.000000	0.006890	0.005166	33.46352		
1.111111	0.007273	0.005953	40.86528		
1.222222	0.007656	0.006783	49.06331		
1.333333	0.008039	0.007655	58.08030		
1.444444	0.008422	0.008569	67.93920		
1.555556	0.008806	0.009526	78.66312		
1.666667	0.009189	0.010526	90.27521		
1.777778	0.009572	0.011568	102.7986		
1.888889	0.009955	0.012653	116.2564		
2.000000	0.010339	0.013781	130.6714		
2.111111	0.010722	0.014951	146.0666		
2.222222	0.011106	0.016163	162.4646		
2.333333	0.011489	0.017419	179.8879		
2.444444	0.011873	0.018716	198.3588		
2.555556	0.012256	0.020057	217.8995		
2.666667	0.012640	0.021440	238.5321		
2.777778	0.013023	0.022866	260.2784		
2.888889	0.013407	0.024334	283.1600		
3.000000	0.013791	0.025845	307.1984		
3.111111	0.014174	0.027399	332.4150		
3.222222	0.014558	0.028995	358.8310		
3.333333	0.014942	0.030634	386.4672		
3.444444	0.015326	0.032315	415.3447		
3.555556	0.015709	0.034039	445.4840		
3.666667	0.016093	0.035806	476.9057		
3.777778	0.016477	0.037616	509.6302		
3.888889	0.016861	0.039468	543.6778		
4.000000	0.017245	0.041363	579.0685		
4.111111	0.017629	0.043300	615.8224		
4.222222	0.018013	0.045280	653.9592		
4.333333	0.018397	0.047303	693.4986		
4.444444	0.018781	0.049369	734.4603		
4.555556	0.019166	0.051477	776.8636		
4.666667	0.019550	0.053628	820.7279		
4.777778	0.019934	0.055821	866.0724		
4.888889	0.020318	0.058057	912.9161		
5.000000	0.020702	0.060336	961.2781		
5.111111	0.021087	0.062658	1011.177		
5.222222	0.021471	0.065022	1062.632		
5.333333	0.021856	0.067429	1115.661		
5.444444	0.022240	0.069879	1170.284		
5.555556	0.022624	0.072372	1226.517		
5.666667	0.023009	0.074907	1284.381		
5.777778	0.023393	0.077485	1343.892		
5.888889	0.023778	0.080105	1405.069		
6.000000	0.024163	0.082769	1467.931		
6.111111	0.024547	0.085475	1532.494		

6.222222	0.024932	0.088224	1598.778
6.333333	0.025316	0.091015	1666.799
6.444444	0.025701	0.093849	1736.575
6.555556	0.026086	0.096726	1808.124
6.666667	0.026471	0.099646	1881.464
6.777778	0.026856	0.102609	1956.611
6.888889	0.027240	0.105614	2033.583
7.000000	0.027625	0.108662	2112.398
7.111111	0.028010	0.111753	2193.073
7.222222	0.028395	0.114887	2275.623
7.333333	0.028780	0.118063	2360.068
7.444444	0.029165	0.121282	2446.423
7.555556	0.029550	0.124544	2534.706
7.666667	0.029935	0.127849	2624.933
7.777778	0.030321	0.131197	2717.120
7.888889	0.030706	0.134587	2811.286
8.000000	0.031091	0.138020	2907.445
8.111111	0.031476	0.141496	3005.616
8.222222	0.031861	0.145015	3105.813
8.333333	0.032247	0.148576	3208.054
8.444444	0.032632	0.152181	3312.355
8.555556	0.033017	0.155828	3418.732
8.666667	0.033403	0.159518	3527.202
8.777778	0.033788	0.163251	3637.779
8.888889	0.034174	0.167027	3750.482
9.000000	0.034559	0.170845	3865.325
9.111111	0.034945	0.174706	3982.324
9.222222	0.035330	0.178611	4101.496
9.333333	0.035716	0.182558	4222.856
9.444444	0.036102	0.186547	4346.420
9.555556	0.036487	0.190580	4472.204
9.666667	0.036873	0.194656	4600.223
9.777778	0.037259	0.198774	4730.493
9.888889	0.037644	0.202935	4863.030
10.000000	0.038030	0.207140	4997.848

END FTABLE 9

END FTABLES

EXT SOURCES

<-Volume->	<Member>	SsysSgap<--Mult-->	Tran	<-Target vols>	<-Grp>	<-Member->	***	
<Name>	#	<Name>	#	tem strg<-factor->	strg	<Name>	# #	***
WDM	2	PREC	ENGL	1	PERLND	1 999 EXTNL	PREC	
WDM	2	PREC	ENGL	1	IMPLND	1 999 EXTNL	PREC	
WDM	1	EVAP	ENGL	1	PERLND	1 999 EXTNL	PETINP	
WDM	1	EVAP	ENGL	1	IMPLND	1 999 EXTNL	PETINP	
WDM	2	PREC	ENGL	1	RCHRES	1	EXTNL	PREC
WDM	2	PREC	ENGL	1	RCHRES	3	EXTNL	PREC
WDM	2	PREC	ENGL	1	RCHRES	5	EXTNL	PREC
WDM	2	PREC	ENGL	1	RCHRES	7	EXTNL	PREC
WDM	1	EVAP	ENGL	0.5	RCHRES	1	EXTNL	POTEV
WDM	1	EVAP	ENGL	1	RCHRES	2	EXTNL	POTEV
WDM	1	EVAP	ENGL	0.5	RCHRES	3	EXTNL	POTEV
WDM	1	EVAP	ENGL	1	RCHRES	4	EXTNL	POTEV
WDM	1	EVAP	ENGL	0.5	RCHRES	5	EXTNL	POTEV
WDM	1	EVAP	ENGL	1	RCHRES	6	EXTNL	POTEV
WDM	1	EVAP	ENGL	0.5	RCHRES	7	EXTNL	POTEV
WDM	1	EVAP	ENGL	1	RCHRES	8	EXTNL	POTEV

END EXT SOURCES

EXT TARGETS

<-Volume->	<-Grp>	<-Member->	<--Mult-->	Tran	<-Volume->	<Member>	Tsys	Tgap	Amd	***	
<Name>	#	<Name>	#	#<-factor->	strg	<Name>	#	<Name>	tem	strg	strg***
RCHRES	2	HYDR	RO	1 1	1	WDM	1000	FLOW	ENGL	REPL	
RCHRES	2	HYDR	STAGE	1 1	1	WDM	1001	STAG	ENGL	REPL	
RCHRES	1	HYDR	STAGE	1 1	1	WDM	1002	STAG	ENGL	REPL	
RCHRES	1	HYDR	O	1 1	1	WDM	1003	FLOW	ENGL	REPL	
COPY	2	OUTPUT	MEAN	1 1	12.1	WDM	702	FLOW	ENGL	REPL	
COPY	502	OUTPUT	MEAN	1 1	12.1	WDM	802	FLOW	ENGL	REPL	
RCHRES	4	HYDR	RO	1 1	1	WDM	1004	FLOW	ENGL	REPL	

RCHRES	4	HYDR	STAGE	1	1	1	WDM	1005	STAG	ENGL	REPL
RCHRES	3	HYDR	STAGE	1	1	1	WDM	1006	STAG	ENGL	REPL
RCHRES	3	HYDR	O	1	1	1	WDM	1007	FLOW	ENGL	REPL
COPY	3	OUTPUT	MEAN	1	1	12.1	WDM	703	FLOW	ENGL	REPL
COPY	503	OUTPUT	MEAN	1	1	12.1	WDM	803	FLOW	ENGL	REPL
RCHRES	6	HYDR	RO	1	1	1	WDM	1008	FLOW	ENGL	REPL
RCHRES	6	HYDR	STAGE	1	1	1	WDM	1009	STAG	ENGL	REPL
RCHRES	5	HYDR	STAGE	1	1	1	WDM	1010	STAG	ENGL	REPL
RCHRES	5	HYDR	O	1	1	1	WDM	1011	FLOW	ENGL	REPL
COPY	4	OUTPUT	MEAN	1	1	12.1	WDM	704	FLOW	ENGL	REPL
COPY	504	OUTPUT	MEAN	1	1	12.1	WDM	804	FLOW	ENGL	REPL
RCHRES	8	HYDR	RO	1	1	1	WDM	1012	FLOW	ENGL	REPL
RCHRES	8	HYDR	STAGE	1	1	1	WDM	1013	STAG	ENGL	REPL
RCHRES	7	HYDR	STAGE	1	1	1	WDM	1014	STAG	ENGL	REPL
RCHRES	7	HYDR	O	1	1	1	WDM	1015	FLOW	ENGL	REPL
COPY	5	OUTPUT	MEAN	1	1	12.1	WDM	705	FLOW	ENGL	REPL
COPY	505	OUTPUT	MEAN	1	1	12.1	WDM	805	FLOW	ENGL	REPL
RCHRES	9	HYDR	RO	1	1	1	WDM	1016	FLOW	ENGL	REPL
RCHRES	9	HYDR	STAGE	1	1	1	WDM	1017	STAG	ENGL	REPL
COPY	1	OUTPUT	MEAN	1	1	12.1	WDM	701	FLOW	ENGL	REPL
COPY	501	OUTPUT	MEAN	1	1	12.1	WDM	801	FLOW	ENGL	REPL

END EXT TARGETS

MASS-LINK

<Volume>	<-Grp>	<-Member->	<--Mult-->	<Target>	<-Grp>	<-Member->***
<Name>		<Name> #	#<-factor->	<Name>		<Name> # #***
MASS-LINK		2				
PERLND	PWATER	SURO	0.083333	RCHRES	INFLOW	IVOL
END MASS-LINK		2				
MASS-LINK		3				
PERLND	PWATER	IFWO	0.083333	RCHRES	INFLOW	IVOL
END MASS-LINK		3				
MASS-LINK		5				
IMPLND	IWATER	SURO	0.083333	RCHRES	INFLOW	IVOL
END MASS-LINK		5				
MASS-LINK		6				
RCHRES	ROFLOW			RCHRES	INFLOW	
END MASS-LINK		6				
MASS-LINK		7				
RCHRES	OFLOW	OVOL	1	RCHRES	INFLOW	IVOL
END MASS-LINK		7				
MASS-LINK		8				
RCHRES	OFLOW	OVOL	2	RCHRES	INFLOW	IVOL
END MASS-LINK		8				
MASS-LINK		12				
PERLND	PWATER	SURO	0.083333	COPY	INPUT	MEAN
END MASS-LINK		12				
MASS-LINK		13				
PERLND	PWATER	IFWO	0.083333	COPY	INPUT	MEAN
END MASS-LINK		13				
MASS-LINK		15				
IMPLND	IWATER	SURO	0.083333	COPY	INPUT	MEAN
END MASS-LINK		15				
MASS-LINK		16				
RCHRES	ROFLOW			COPY	INPUT	MEAN
END MASS-LINK		16				
MASS-LINK		17				
RCHRES	OFLOW	OVOL	1	COPY	INPUT	MEAN
END MASS-LINK		17				

MASS-LINK 18
RCHRES OFLOW OVOL 2 COPY INPUT MEAN
END MASS-LINK 18

END MASS-LINK

END RUN

Predeveloped HSPF Message File

Mitigated HSPF Message File

Disclaimer

Legal Notice

This program and accompanying documentation are provided 'as-is' without warranty of any kind. The entire risk regarding the performance and results of this program is assumed by End User. Clear Creek Solutions Inc. and the governmental licensee or sublicensees disclaim all warranties, either expressed or implied, including but not limited to implied warranties of program and accompanying documentation. In no event shall Clear Creek Solutions Inc. be liable for any damages whatsoever (including without limitation to damages for loss of business profits, loss of business information, business interruption, and the like) arising out of the use of, or inability to use this program even if Clear Creek Solutions Inc. or their authorized representatives have been advised of the possibility of such damages. Software Copyright © by : Clear Creek Solutions, Inc. 2005-2015; All Rights Reserved.

Clear Creek Solutions, Inc.
6200 Capitol Blvd. Ste F
Olympia, WA. 98501
Toll Free 1(866)943-0304
Local (360)943-0304

www.clearcreeksolutions.com

Kimley»Horn

Appendix B

GEOTECHNICAL INVESTIGATION DESIGN PHASE

FOR
MONTEREY COUNTY ADULT JAIL HOUSING ADDITION
SALINAS, CALIFORNIA

PREPARED FOR
HMC + BEVERLY PRIOR ARCHITECTS
PROJECT NO. 12-126-M



PREPARED BY

BUTANO GEOTECHNICAL ENGINEERING, INC.
OCTOBER 2013



BUTANO GEOTECHNICAL ENGINEERING, INC.

231 GREEN VALLEY ROAD, SUITE E, FREEDOM, CALIFORNIA 95019

PHONE: 831.724.2612

WWW.BUTANOGEOTECH.COM

July 29, 2013
Project No. 12-126-M

HMC + Beverly Prior Architects
417 Montgomery Street, 8th Floor
San Francisco, CA 94104

ATTENTION: Julia Hughes

SUBJECT: **GEOTECHNICAL INVESTIGATION - DESIGN PHASE**

Proposed Adult Jail Housing Addition
Monterey County Adult Jail Facility
1410 Natividad Road, Salinas, California

Dear Mrs. Hughes:

In accordance with your authorization, we have completed a geotechnical investigation for the subject project. This report summarizes the findings, conclusions, and recommendations from our field exploration, laboratory testing, and engineering analysis. It is a pleasure being associated with you on this project. If you have any questions, or if we may be of further assistance, please do not hesitate to contact our office.

Sincerely,

BUTANO GEOTECHNICAL ENGINEERING, INC.

Greg Bloom, PE, GE
Principal Engineer
R.C.E. 58819, G.E. 2691
Expires 6/30/13

Appendices	Appendix A	Figures and Standard Details
	Appendix B	Field Exploration Program
	Appendix C	Laboratory Testing Program
	Appendix D	Pavement Deflection Analysis
	Appendix E	Corrosion Analysis

Distribution: (6) Addressee

1.0 INTRODUCTION

This report presents the results of our geotechnical investigation for the proposed Monterey County Adult Jail Housing Addition at 1410 Natividad Road in Salinas, Monterey County, California.

The purpose of our investigation is to provide information regarding the surface and subsurface soil conditions and provide geotechnical recommendations for the design and construction of the proposed Jail Housing Addition Project (Project). Conclusions and recommendations related to site grading, foundations, retaining walls, pavement design, corrosion protection and drainage are presented herein.

This work included site reconnaissance, subsurface exploration, soil sampling, laboratory testing, engineering analyses and preparation of this report. The scope of services for this investigation is outlined in our agreement dated November 16, 2012.

The recommendations contained in this report are subject to the limitations presented in Section 8.0 of this report. The Association of Engineering Firms Practicing the Geosciences has produced a pamphlet for your information titled *Important Information About Your Geotechnical Report*. This pamphlet has been included with the copies of your report.

2.0 FIELD EXPLORATION AND LABORATORY TESTING PROGRAMS

Our field exploration program included drilling, logging, and interval sampling of 14 truck mounted solid stem auger borings advanced on April 10, 11, and 12, 2013. In addition, we cored and hand augered 4 borings along Chaparral Street on August 27, 2013. The borings were advanced to depths ranging from 4 to 61½ feet below existing grade. Details of the field exploration program, including the Boring Logs, Figures B-4 through B-17, are presented in Appendix B.

Representative samples obtained during the field investigation were taken to the laboratory for testing to determine physical and engineering properties. Details of the laboratory testing program are presented in Appendix C. Test results are presented on the Boring Logs and in Appendix C.

Samples for the corrosion analysis were also collected during the subsurface exploration program. The collected corrosion samples were shipped directly to JDH Corrosion Consultants, Inc. for analysis. The result of their analysis is presented in Appendix E.

R-value samples were collected by our firm and sent to Cooper Testing Laboratories for testing. Pavement Engineering Inc. performed a deflection analysis of Chaparral Street. The results of the deflection testing and deflection analysis are presented in Appendix D.

3.0 SITE AND PROJECT DESCRIPTION

3.1 Location

The Project is located east of Highway 101 in Salinas, California. The site location is shown on the Site Location Plan, Appendix B, Figure B-1.

3.2 Surface Conditions

The proposed Project area is located adjacent to the existing Monterey County Adult Jail. The Project will be located within an area that is currently occupied by a paved parking lot and an open field, currently enclosed by a cyclone fence. The paved entrance road (Chaparral Street) between Natividad Road and the Project is also within the project limits.

The area of proposed expansion is relatively flat with very gentle gradients to the south. The enclosed field area is vegetated with grass.

Chaparral Street dips down then up (through a historic drainage which has been infilled) off of Natividad Road. The rest of Chaparral is relatively level.

3.3 Subsurface Conditions

A total of 14 borings (10 within the Project and 4 along the entrance road) were advanced ranging in depth from 4 to 61 ½ feet below existing grade.

The jail expansion envelope is mapped as being underlain by older alluvial deposits. Locally, these deposits consist of lean clay, sandy lean clay, fat clay, sandy fat clay, clayey sand, sandy silty and silty sand. The clays encountered were generally stiff to hard and the sands were medium dense to very dense.

Within the enclosed field (B-5, B-6, B-9, and B-10) fill was encountered in the upper 2 to 4 feet. The fill consists of sandy lean and fat clay with some gravel. The fill is hard based on our borings.

Groundwater was encountered within our deeper (61½ foot) borings. The depth to groundwater recorded was 46, 41½, and 40 feet in B7, B8, and B9 respectively.

Complete soil profiles are presented on the Boring Logs, Appendix B, Figures B-4 through B-17. The boring locations are shown on the Boring Location Plan, Figure B-2.

4.0 PROJECT DESCRIPTION

Based on our discussions with the client the Project will consist of constructing a new one story building with housing unit tiers in Phase I and a two story building with housing unit tiers on each level in Phase II. The preliminary plan consists of a building footprint of approximately 73,700 square feet (Phase I and II combined). It is our understanding that the floor of the structure will consist of a concrete slab-on-grade.

The entrance road (Chaparral Street) between Natividad and the building envelope is also part of the project. The road was evaluated with respect to its ability to handle an increase in truck traffic associated with the addition.

5.0 GEOTECHNICAL HAZARDS

5.1 General

In our opinion the geotechnical hazards that could potentially affect the proposed project are:

- Fault surface rupture
- Intense seismic shaking
- Collateral seismic hazards
- Landslide
- Erosion

5.2 Fault Surface Rupture

The site lies outside of the State of California, Alquist-Priolo Earthquake Fault Zone. The site is approximately 18 Km from the San Andreas fault. No fault traces are mapped on the subject property. It is our opinion that the potential for fault surface rupture to affect the site and/or to damage the proposed addition is low.

5.3 Intense Seismic Shaking

Intense seismic shaking may occur at the site during the design lifetime of the proposed structure from an earthquake along one of the local fault systems. Generally, the intensity of shaking will increase the closer the site is to the epicenter of an earthquake, however, seismic shaking is a complex phenomenon and may be modified by local topography and soil conditions. The transmission of earthquake vibrations from the ground into the structure may cause structural damage.

Monterey County has adopted the seismic provisions set forth in the California Building Code to address seismic shaking. The seismic provisions in the CBC are minimum load requirements for the seismic design for the proposed structure. The provisions set forth in the CBC will not prevent structural and nonstructural damage from direct fault ground surface rupture, coseismic ground cracking, liquefaction and lateral spreading, seismically induced differential compaction, seismically induced landsliding, or seismically induced inundation.

Table 1 has been constructed based on the 2013 CBC requirements for the seismic design of the proposed structure. The Site Class has been determined based on our field investigation and laboratory testing.

Table 1. Seismic Design Parameters

S _s	S ₁	Site Class	F _a	F _v	S _{MS}	S _{M1}	S _{DS}	S _{D1}	Occupancy Category	Seismic Design Category
1.500	0.600	D	1.0	1.5	1.500	0.900	1.000	0.600	II	D

5.4 Collateral Seismic Hazards

In addition to intense seismic shaking, other seismic hazards that may have an adverse affect to the site and/or the structure are: coseismic ground cracking, seismically induced liquefaction and lateral spreading, seismically induced differential compaction, seismically induced landsliding, and seismically induced inundation (tsunami and seiche). Due to the location of the proposed development away from earthquake faults and the strength of the underlying geologic units, the potential for collateral seismic hazards to affect the site and/or to damage the proposed addition is low.

5.5 Landslide

Landslide is a general term referring to the downslope movement of soil and/or rock en masse, under the influence of gravity. The area of proposed expansion is relatively flat with very gentle gradients to the south. Due to the flat terrain and the strength of the underlying geologic units and the lack of previous landsliding in the general area, the potential for landsliding to affect the site and/or to damage the proposed addition is low.

5.6 Erosion

Erosion is the general process where surficial earth materials are loosened, dissolved or worn away and simultaneously moved from one place to another by water or wind. The area of proposed expansion has been previously graded and is relatively flat with very gentle gradients to the south. No drainage courses cross the property. The currently proposed development does not include significant changes to the surface gradients. Given that the site is developed following our recommendations and mandated erosion control guidelines, the potential for erosion to affect the site is low.

6.0 DISCUSSIONS AND CONCLUSIONS

Based on our field investigation, and discussion with the owner it is proposed that the Project will be expanded with an independent one-structure with housing tiers in Phase I and a two-story structure with housing tiers in Phase II. It is our understanding that the floor of the structure will consist of a concrete slab-on-grade.

The foundation zone soils consist of lean and fat clays. The clays are stiff to very stiff. Expansion Index tests were performed on multiple bulk samples within the foundation zone. The results vary between 2 and 78 indicating an expansion potential varying from low to medium.

The field area within the cyclone fencing is underlain by approximately 2 feet of fill. The soil sampled during our exploration is very stiff to hard. Although it appears that this material has been compacted we do not have any engineering records of its placement.

The soil encountered in the upper 10 feet generally consists of lean and fat clays. It is our opinion that on-site retention of collected storm drainage is not feasible given the low percolation rates of the in-situ soil.

7.0 RECOMMENDATIONS

7.1 General

Based on the results of our field investigation, laboratory testing, and engineering analysis it is our opinion that from the geotechnical standpoint, the subject site will be suitable for the proposed construction.

The existing entrance road pavement section was evaluated for its ability to withstand an increase in traffic loading. Based on the deflection testing and existing pavement section, the pavement is structurally adequate for a traffic index of 5.5. It is recommended that pavement section be adequately maintained. Detailed maintenance options are provided within the text of the pavement deflection analysis report in Appendix D.

The site is underlain by potentially expansive soil within the foundation zone. This report provides two detailed options to mitigate the heave. This includes a structural slab-on-grade (no soil improvement) or soil improvement to alter the swelling characteristics of the soil and found the structure on a conventional shallow foundation with non-structural slab-on-grade floors.

A corrosion analysis was performed for this project. The results and recommendations of the analysis are presented in Appendix E.

7.2 Site Grading

7.2.1 Site Clearing

The site should be cleared of loose soil, organics, and debris within the project limits.

7.2.2 Preparation of On-Site Soils

Areas to receive fill should be over-excavated down to the in-situ soil, scarified, moisture conditioned to 3 to 5 percent over optimum moisture content, and compacted to between 86 and 88 percent relative compaction.

Structural Slab-On-Grade Option

All on-site fill (lean and fat clay) should be compacted with heavy vibratory equipment to 86 to 88 percent relative compaction with moisture content between 3 to 5 percent over optimum. Fill should be compacted by mechanical means in uniform horizontal loose lifts not exceeding 8 inches in thickness. The relative compaction and required moisture content shall be based on the maximum dry density and optimum moisture content obtained in accordance with ASTM D1557.

The on-site soil may be used as engineered fill once the majority of deleterious material is removed. The material should be verified by a representative of Butano Geotechnical Engineering, Inc. in the field during grading operations. All soils, both existing on-site and imported, to be used as fill, should contain less than 3 percent organics and be free of debris and cobbles over 2½ inches in maximum dimension.

Conventional Shallow Foundation Option

Conventional shallow foundations and non-structural slab-on-grades should be founded on a minimum of 24 inches of non-expansive engineered fill. The non-expansive fill may consist of imported soil or chemically altered on-site soil. The non-expansive fill should be compacted to a minimum of 90 percent relative compaction.

Chemically altering the soil may consist of lime treating the soil to minimize its swell potential. If this option is chosen, testing of the soil to determine the appropriate mix ratio and ensure that the soil reacts is required.

Exterior Slab-on-Grades (non-structural)

Exterior slab-on-grades should be founded on a minimum of 12 inches of either chemically altered soil (lime treatment) or imported engineered fill. Exterior slab-on-grades should be physically separated from the structure.

General

The upper 6 inches of subgrade below paved areas and all aggregate baserock should be compacted to a minimum of 95 percent relative compaction. This should extend a minimum of 2 feet laterally of all paved areas.

The on-site soil maynot be used as engineered fill unless chemically altered so it has a low expansion potential. The material should be verified by a representative of Butano Geotechnical Engineering, Inc. in the field during grading operations. All soils, both existing on-site and imported, to be used as fill, should contain less than 3 percent organics and be free of debris and cobbles over 2½ inches in maximum dimension.

Imported fill material should be approved by a representative of Butano Geotechnical Engineering, Inc. prior to importing. Imported fill should be primarily granular with no material greater than 2½ inches in diameter and no more than 20 percent of the material passing the #200 sieve. The fines fraction of the fill should not consist of expansive material. The Geotechnical Engineer should be notified not less than 5 working days in advance of placing any fill or base course material proposed for import. Each proposed source of import material should be sampled, tested, and approved by the Geotechnical Engineer prior to delivery of any soils imported for use on the site.

Any surface or subsurface obstruction, or questionable material encountered during grading, should be brought immediately to the attention of the Geotechnical Engineer for proper processing as required.

7.2.3 Cut and Fill Slopes

Cut and fill slopes are not planned for this project.

7.2.4 Excavating Conditions

The on-site soil may be excavated and drilled with standard earthwork equipment.

7.2.5 Surface Drainage

Positive drainage should be maintained away from the structures at a minimum gradient of 5 percent for 10 feet. Roof and driveway drainage should be collected into solid plastic pipe and released at approved locations to minimize erosion.

7.2.6 Utility Trenches

Bedding material should consist of sand with a Sand Equivalent not less than 30 which may then be jetted.

The on-site native soils may not be utilized for trench backfill per section 7.2.2 unless chemically altered to reduce its expansion potential. Imported fill should be free of organic material and rocks over 2.5 inches in diameter.

If sand is used, a 3 foot concrete plug should be placed in each trench where it passes under the exterior footings.

Backfill of all exterior and interior trenches should be placed in thin lifts not to exceed 8 inches and mechanically compacted to achieve a relative compaction of not less than 95 percent in paved areas and 90 percent in other areas per ASTM D1557. Care should be taken not to damage utility lines.

Utility trenches that are parallel to the sides of a building should be placed so that they do not extend below a line sloping down and away at an inclination of 2:1 H:V from the bottom outside edge of all footings.

Trenches should be capped with 1 1/2 feet of relatively impermeable material. Import material must be approved by the Geotechnical Engineer prior to its use.

Trenches must be shored as required by the local regulatory agency, the State Of California Division of Industrial Safety Construction Safety Orders, and Federal OSHA requirements.

7.3 Foundations

Two options for supporting the proposed Project are provided below. Additional options can be provided if desired.

7.3.1 Option 1 - Post-Tensioned Slab-on-Grade Foundation

This option consists of constructing a post-tensioned slab-on-grade that is designed to mitigate heave potential based on its rigidity. Post-tensioned slabs should be designed in accordance with the latest recommendations of the Post-Tensioning Institute using the following criteria.

- a. Depth to constant moisture= 15 feet from existing grade
- b. Effective Plasticity Index=50
- c. Allowable Bearing Capacity=3,500 psf
- d. $e_m=9.0$ for center lift and 4.9 for edge lift
- e. $y_m=0.54$ for center lift and 0.55 for edge lift

Where moisture sensitive floor coverings are anticipated or vapor transmission may be a problem, place an 11 mil waterproof membrane directly below the floor slab in order to reduce moisture condensation under the floor coverings. Place a six inch layer of Class II baserock below the vapor barrier, and a 4 inch minimum layer of $\frac{3}{4}$ inch drainrock below the baserock to act as a capillary break.

7.3.2 Option 2 - Conventional Shallow Foundations

Conventional shallow foundations may be used if the subgrade soil is altered to reduce its swell potential. Under this option the base of the foundation and slab-on-grade should be underlain by a minimum of 24 inches of non-expansive soil. The 24 inches may consist of imported engineered fill or on-site soil that has been chemically altered (lime treated) to mitigate its swell potential.

Footing widths should be based on the allowable bearing value but not less than 15 inches. The minimum recommended depth of embedment is 12 inches. Embedment depths should not be allowed to be affected

adversely, such as through erosion, softening, digging, etc. Should local building codes require deeper embedment of the footings or wider footings, the local codes must apply.

The allowable bearing capacity used should not exceed 3,500 psf for footings bearing on engineered fill. The allowable bearing capacity may be increased by one-third in the case of short duration loads, such as those induced by wind or seismic forces. In the event that footings are founded in structural fill consisting of imported materials, the allowable bearing capacities will depend on the type of these materials and should be re-evaluated.

Friction coefficient - 0.30, between the engineered fill and rough concrete. A passive resistance of 250 pcf may be assumed below a depth of 12 inches. Where both friction and the passive resistance are utilized for sliding resistance, either of the values indicated should be reduced by one-third.

Footing excavations must be checked by the Geotechnical Engineer before steel is placed and concrete is poured.

7.3.3 Option 2 - Concrete Slabs-on-Grade (non-structural)

We recommend that concrete slab-on-grades be founded on 24 inches of either imported engineered fill or chemically altered (lime treated) in-situ soil per section 7.2.2.

The subgrade should be proof-rolled just prior to construction to provide a firm, relatively unyielding surface, especially if the surface has been loosened by the passage of construction traffic.

Where moisture sensitive floor coverings are anticipated or vapor transmission may be a problem, an 11 mil waterproof membrane should be placed directly below the floor slab in order to reduce moisture condensation under the floor coverings. A six inch layer of Class II baserock should be placed below the vapor barrier. A 4 inch minimum layer of $\frac{3}{4}$ inch drainrock should be placed below the baserock to act as a capillary break.

7.3.4 Settlements

Total and differential settlements beneath the proposed retaining wall are expected to be within tolerable limits under static conditions. Vertical movements are not expected to exceed 1 inch. Differential movements are expected to be within the normal range (½ inch) for the anticipated loads.

7.5 Plan Review

The recommendations presented in this report are based on preliminary design information for the proposed project and on the findings of our geotechnical investigation. When completed, the Grading Plans, Foundation Plans and design loads should be reviewed by Butano Geotechnical Engineering, Inc. prior to submitting the plans and contract bidding. Additional field exploration and laboratory testing may be required upon review of the final project design plans.

7.6 Observation and Testing

Field observation and testing must be provided by a representative of Butano Geotechnical Engineering, Inc. to enable them to form an opinion regarding the adequacy of the site preparation, the adequacy of fill materials, and the extent to which the earthwork is performed in accordance with the geotechnical conditions present, the requirements of the regulating agencies, the project specifications, and the recommendations presented in this report. Any earthwork performed in connection with the subject project without the full knowledge of, and not under the direct observation of Butano Geotechnical Engineering, Inc., will render the recommendations of this report invalid.

Butano Geotechnical Engineering, Inc. should be notified at least 5 working days prior to any site clearing or other earthwork operations on the subject project in order to observe the stripping and disposal of unsuitable materials and to ensure coordination with the grading contractor. During this period, a preconstruction meeting should be held on the site to discuss project specifications, observation and testing requirements and responsibilities, and scheduling.

8.0 LIMITATIONS

The recommendations contained in this report are based on our field explorations, laboratory testing, and our understanding of the proposed construction. The subsurface data used in the preparation of this report was obtained from the borings drilled during our field investigation. Variation in soil, geologic, and groundwater conditions can vary

significantly between sample locations. As in most projects, conditions revealed during construction excavation may be at variance with preliminary findings. If this occurs, the changed conditions must be evaluated by the Project Geotechnical Engineer and the Geologist, and revised recommendations be provided as required. In addition, if the scope of the proposed construction changes from the described in this report, our firm should also be notified.

Our investigation was performed in accordance with the usual and current standards of the profession, as they relate to this and similar localities. No other warranty, expressed or implied, is provided as to the conclusions and professional advice presented in this report.

This report is issued with the understanding that it is the responsibility of the Owner, or of his Representative, to ensure that the information and recommendations contained herein are brought to the attention of the Architect and Engineer for the project and incorporated into the plans, and that it is ensured that the Contractor and Subcontractors implement such recommendations in the field. The use of information contained in this report for bidding purposes should be done at the Contractor's option and risk.

This firm does not practice or consult in the field of safety engineering. We do not direct the Contractor's operations, and we are not responsible for other than our own personnel on the site; therefore, the safety of others is the responsibility of the Contractor. The Contractor should notify the Owner if he considers any of the recommended actions presented herein to be unsafe.

The findings of this report are considered valid as of the present date. However, changes in the conditions of a site can occur with the passage of time, whether they be due to natural events or to human activities on this or adjacent sites. In addition, changes in applicable or appropriate codes and standards may occur, whether they result from legislation or the broadening of knowledge. Accordingly, this report may become invalidated wholly or partially by changes outside our control. Therefore, this report is subject to review and revision as changed conditions are identified.

The scope of our services mutually agreed upon did not include any environmental assessment or study for the presence of hazardous to toxic materials in the soil, surface water, or air, on or below or around the site. Butano Geotechnical Engineering, Inc. is not a mold prevention consultant; none of our services performed in connection with the proposed project are for the purpose of mold prevention. Proper implementation of the recommendations conveyed in our reports will not itself be sufficient to prevent mold from growing in or on the structures involved.

REFERENCES

ASTM International (2006).Annual Book of ASTM Standards, Section Four, Construction.Volume 4.08, Soil and Rock (I): D 430 - D 5611.

ASTM International (2006).Annual Book of ASTM Standards, Section Four, Construction.Volume 4.09, Soil and Rock (II): D 5714 - Latest.

California Building Code (2010).

Geologic Map of the Monterey Peninsula and Vicinity by Thomas W. Dibblee, Jr., 1999, Map #DF-71

APPENDIX A

FIGURES AND STANDARD DETAILS

Surcharge Pressure Diagram

Figure A-1

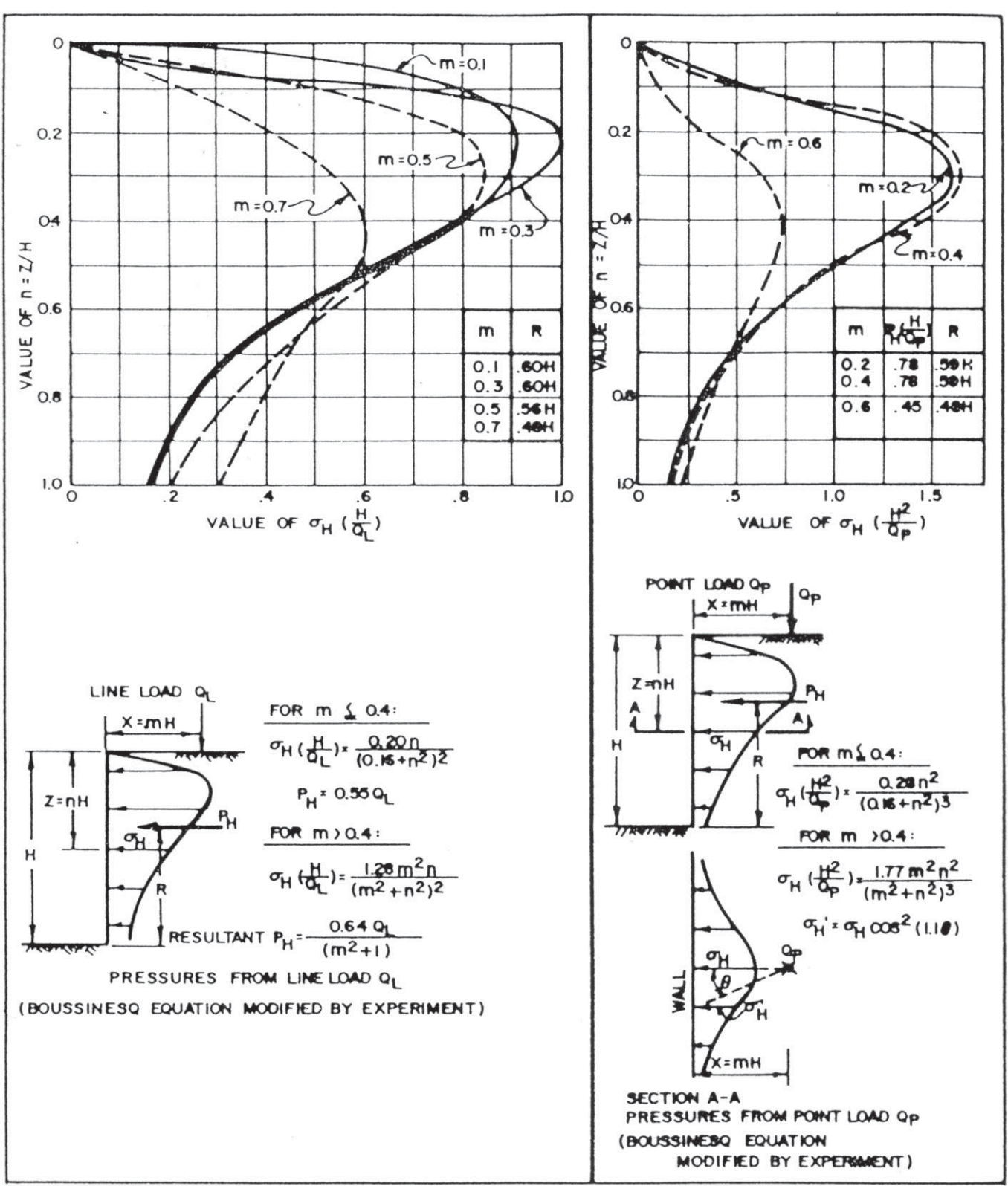

REFERENCE: NAVFAC Design Manual 7.2

Figure 11, Page 7.2-74

APPENDIX B

FIELD EXPLORATION PROGRAM

Field Exploration Procedures	Page B-1
Site Location Plan	Figure B-1
Boring Site Plan	Figure B-2
Key to the Logs	Figure B-3
Logs of the Borings	Figures B-4 through B-17

FIELD EXPLORATION PROCEDURES

Subsurface conditions were explored by advancing 14 borings below existing grade. All borings were advanced using a six inch solid stem truck mounted auger. The Key to The Logs and the Logs of the Borings are included in Appendix B, Figures B-3 through B-17. The approximate locations of the borings are shown on the Boring Site Plan, Figure B-2. The drill holes were located in the field by tape measurements from known landmarks. Their locations as shown are therefore within the accuracy of such measurement.

The soils encountered in the borings were continuously logged in the field by a representative of Butano Geotechnical Engineering, Inc. Bulk and relatively undisturbed soil samples for identification and laboratory testing were obtained in the field. These soils were classified based on field observations and laboratory tests. The classification is in accordance with the Unified Soil Classification System (Figure B-3).

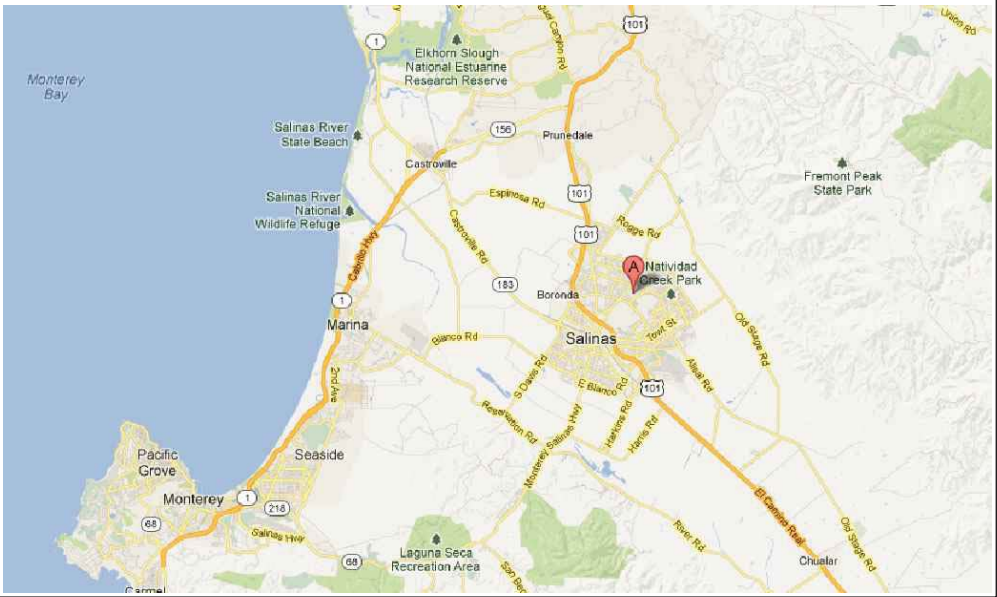
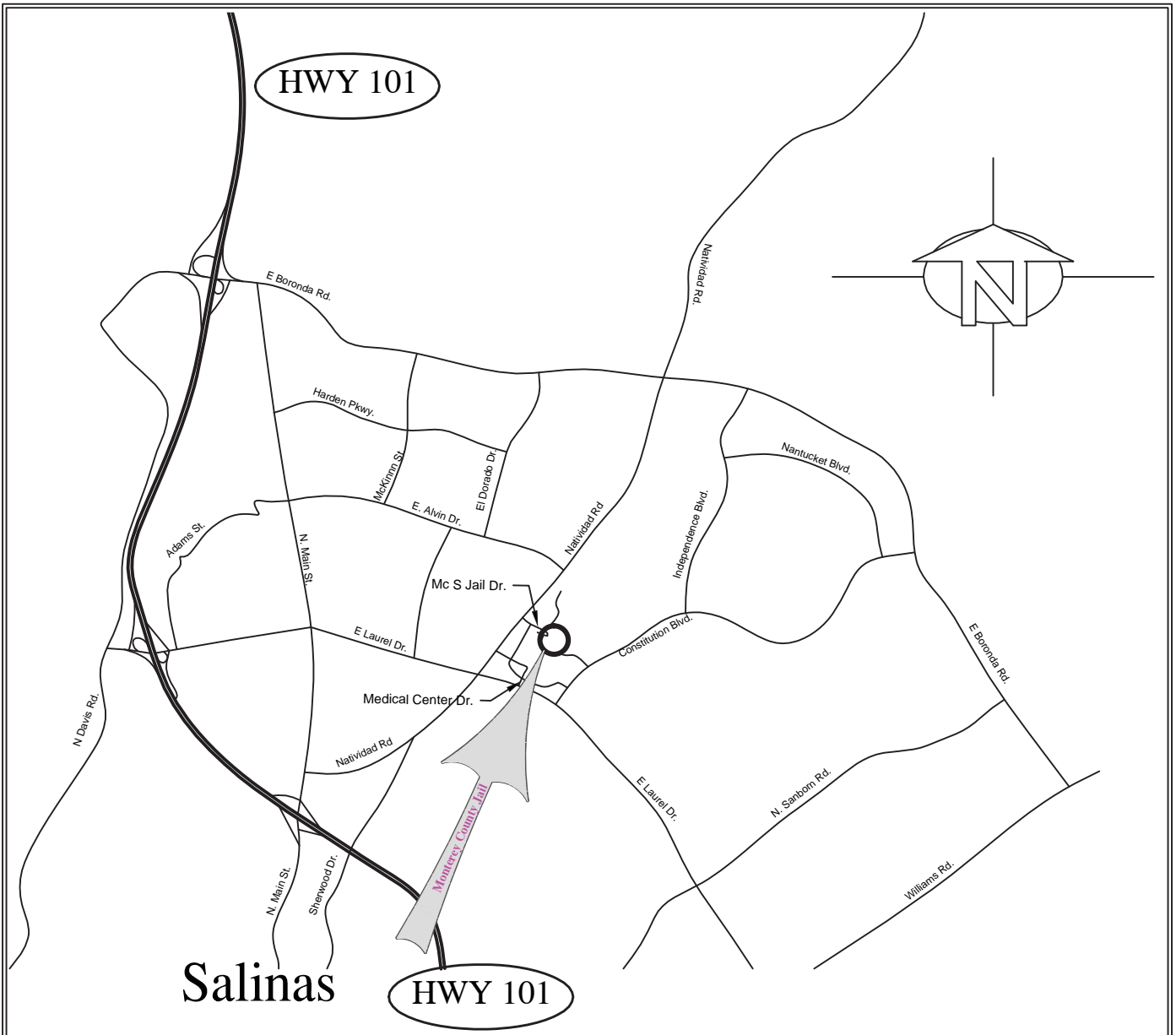

BUTANO GEOTECHNICAL ENGINEERING, INC.	SITE LOCATION PLAN	FIGURE B-1
	Monterey County Adult Jail Housing Addition	

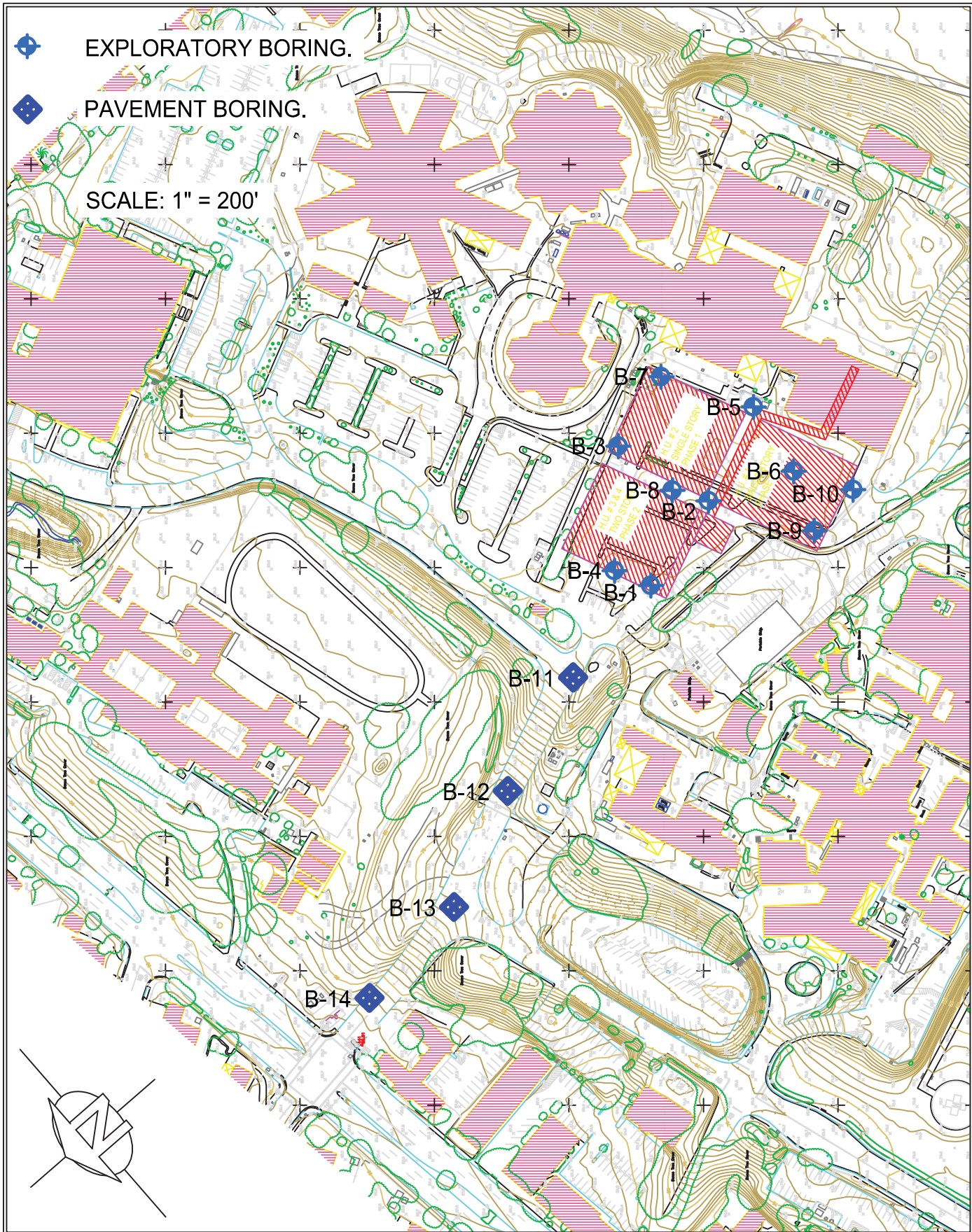

BUTANO
 GEOTECHNICAL ENGINEERING, INC.

BORING SITE PLAN
 Monterey County Adult Jail Housing Addition

FIGURE
 B-2

KEY TO LOGS

UNIFIED SOIL CLASSIFICATION SYSTEM

PRIMARY DIVISIONS			GROUP SYMBOL	SECONDARY DIVISIONS
COARSE GRAINED SOILS More than half of the material is larger than the No. 200 sieve	GRAVELS More than half of the coarse fraction is larger than the No. 4 sieve	CLEAN GRAVELS (Less than 5% fines)	GW	Well graded gravels, gravel-sand mixtures, little or no fines
		GRAVEL WITH FINES	GP	Poorly graded gravels, gravel-sand mixtures, little or no fines
			GM	Silty gravels, gravel-sand-silt mixtures, non-plastic fines
			GC	Clayey gravels, gravel-sand-clay mixtures, plastic fines
	SANDS More than half of the coarse fraction is smaller than the No. 4 sieve	CLEAN SANDS (Less than 5% fines)	SW	Well graded sands, gravelly sands, little or no fines
		SAND WITH FINES	SP	Poorly graded sands, gravelly sands, little or no fines
			SM	Silty sands, sand-silt mixtures, non-plastic fines
			SC	Clayey sands, sand-clay mixtures, plastic fines
FINE GRAINED SOILS More than half of the material is smaller than the No. 200 sieve	SILTS AND CLAYS Liquid limit less than 50		ML	Inorganic silts and very fine sands, silty or clayey fine sands or clayey silts with slight plasticity
	SILTS AND CLAYS Liquid limit greater than 50		CL	Inorganic clays of low to medium plasticity, gravelly clays, sandy clays, silty clays, lean clays
			OL	Organic silts and organic silty clays of low plasticity
			MH	Inorganic silts, micaceous or diatomaceous fine sandy or silty soils, elastic silts
	SILTS AND CLAYS Liquid limit greater than 50		CH	Inorganic clays of high plasticity, fat clays
			OH	Organic clays of medium to high plasticity, organic silts
HIGHLY ORGANIC SOILS			Pt	Peat and other highly organic soils

GRAIN SIZE LIMITS

SILT AND CLAY	SAND			GRAVEL		COBBLES	BOULDERS
	FINE	MEDIUM	COARSE	FINE	COARSE		
No. 200	No. 40	No. 10	No. 4	3/4 in.	3 in.	12 in.	
US STANDARD SIEVE SIZE							

RELATIVE DENSITY	
SAND AND GRAVEL	BLOWS/FT*
VERY LOOSE	0 - 4
LOOSE	4 - 10
MEDIUM DENSE	10 - 30
DENSE	30 - 50
VERY DENSE	OVER 50

CONSISTENCY	
SILT AND CLAY	BLOWS/FT*
VERY SOFT	0 - 2
SOFT	2 - 4
FIRM	4 - 8
STIFF	8 - 16
VERY STIFF	16 - 32
HARD	OVER 32

MOISTURE CONDITION
DRY
MOIST
WET

* Number of blows of 140 pound hammer falling 30 inches to drive a 2 inch O.D. (1 3/8 inch I.D.) split spoon (ASTM D-1586).























LOG OF EXPLORATORY BORING

Project No.: 12-126-M Boring: B1
 Project: Monterey County Adult Jail Housing Addition Location: Reference Boring Site Plan Figure B-2
Elevation:
 Date: April 10, 2013 Method of Drilling: Six inch diameter solid stem truck mounted
 Logged By: PE auger.

Depth (ft.)	Soil Type	Undisturbed	Bulk	<div style="display: flex; justify-content: space-around; font-size: 0.8em;"> 2\" Ring Sample 2.5\" Ring Sample Bulk Sample </div> <div style="display: flex; justify-content: space-around; font-size: 0.8em; margin-top: 5px;"> Terzaghi Split Spoon Sample Static Water Table </div>	Blows / Foot	N ₆₀	Dry Density (pcf)	Moisture Content (%)	Expansion Index	Unconfined Comp. (psf)	Particle Size	Other Tests	
Description													
4	CL			4" Asphalt Concrete over 5 1/2 " Baserock	49	23	121.6	11.7	2	3661			
5				Brown sandy lean CLAY, stiff, moist, low plasticity	19	15		14.4					
5				stiff	22	12	115.1	13.5					1751
10	CH			Brown fat CLAY with some sand, very stiff, moist	54	26	109.2	17.4		7226			
15	ML			Tan sandy SILT, hard, slightly plastic, fine grained sand	76	37	101.9	16.3		7735	✓		
20	CL			Tan lean CLAY with sand, very stiff	56	29	91.1	30.6					
25	CL			Brown gravelly lean CLAY with sand, very stiff, moist	43	23	117.7	13.4					
30				Brown lean CLAY, very stiff, moist	59	31	100.8	24.8					
35				Boring terminated at a depth of 31 1/2 feet. No groundwater encountered.									













LOG OF EXPLORATORY BORING

Project No.: 12-126-M Boring: B2
 Project: Monterey County Adult Jail Housing Addition Location: Reference Boring Site Plan Figure B-2
 Elevation:
 Date: April 10, 2013 Method of Drilling: Six inch diameter solid stem truck mounted
 Logged By: PE auger.

Depth (ft.)	Soil Type	Undisturbed	Bulk	 2" Ring Sample  2.5" Ring Sample  Bulk Sample  Terzaghi Split Spoon Sample  Static Water Table	Blows / Foot	N ₆₀	Dry Density (pcf)	Moisture Content (%)	Expansion Index	Unconfined Comp. (psf)	Swell (psf)	Atterberg Limits	
												L.L.	P.I.
Description													
5	CH			3" Asphalt Concrete over 2 1/2" Baserock	25	70	109.5	12.2	69	7767	1150	62.0	41.5
				Light brown fat CLAY, very stiff, moist	26	22		17.8					
				very stiff some interbedded lenses of calcified soil	80	36	97.5	17.9	71				
				hard very stiff	22	18		21.6					
10				very stiff	47	23	92.8	25.2					
				hard	26	91		21.1					
15	ML			Tan sandy SILT, dense, moist, fine grained	34	31		19.7					
20	CL			Tan lean CLAY, very stiff, moist	26	22		22.3					
				very stiff									
25	Boring terminated at a depth of 21 1/2 feet. No groundwater encountered.												
30													
35													

LOG OF EXPLORATORY BORING

Project No.: 12-126-M Boring: B4
 Project: Monterey County Adult Jail Housing Addition Location: Reference Boring Site Plan Figure B-2
 Date: April 10, 2013 Elevation:
 Logged By: PE Method of Drilling: Six inch diameter solid stem truck mounted auger.

Depth (ft.)	Soil Type	Undisturbed	Bulk	Description	Blows / Foot	N ₆₀	Dry Density (pcf)	Moisture Content (%)	Expansion Index	Unconfined Comp. (psf)	Particle Size	Other Tests		
												2" Ring Sample 2.5" Ring Sample Terzaghi Split Spoon Sample	Bulk Sample Static Water Table	
0	CL			3 3/4 " AC over 4 1/2" Baserock	74	34	105.8	18.7						
5	CH			Brown sandy lean CLAY, very stiff, moist hard	51	46		17.6	42					
5	CH			Tan fat CLAY, very stiff, with lenses of calcification hard	42	20	103.9	20.8						
10				sandy fat CLAY	36	33		23.9						
10					37	18	95.9	18.1						
15	ML			Tan sandy SILT, medium dense, damp, fine grained sand	24	26		14.5						
20	CL			Light brown lean CLAY, very stiff, moist very stiff	27	23		27.5						
25				Boring terminated at a depth of 21 1/2 feet. No groundwater encountered.										
30														
35														













LOG OF EXPLORATORY BORING

Project No.: 12-126-M	Boring: B5	
Project: Monterey County Adult Jail Housing Addition	Location: Reference Boring Site Plan Figure B-2	
Date: April 10, 2013	Elevation:	
Logged By: PE	Method of Drilling: Six inch diameter solid stem truck mounted auger.	

Depth (ft.)	Soil Type	Undisturbed	Bulk	Description	Blows / Foot	N ₆₀	Dry Density (pcf)	Moisture Content (%)	Expansion Index	Unconfined Comp. (psf)	Particle Size	Other Tests	
50-6"	FILL (CL)	☒	☒	Light brown sandy lean CLAY, hard, dry, with gravel (FILL)	50-6"			5.6		13114			
	CL	☒	☒	Light brown sandy lean CLAY, medium dense to dense, dry	26	22		9.7					
5		☒	☒	hard	50-6"		114.0	10.1	28				
		☒	☒	hard	46	42		8.0					
10	SC	☒	☒	Reddish brown clayey SAND, dense, slightly damp	69	34	111.2	10.9					
	CL	☒	☒	Brown sandy lean CLAY very stiff, moist			98.8	25.9					
15		☒	☒	Grades to a lean CLAY, hard	48	47		14.9					
	ML	☒	☒	Lens of tan sandy SILT									
20	CL	☒	☒	Tan lean CLAY with sand, hard, moist, fine grained sand	45	45		30.2					
25				Boring terminated at a depth of 21 1/2 feet. No groundwater encountered.									
30													
35													

LOG OF EXPLORATORY BORING

Project No.: 12-126-M Boring: B6
 Project: Monterey County Adult Jail Housing Addition Location: Reference Boring Site Plan Figure B-2
 Date: April 10, 2013 Elevation:
 Method of Drilling: Six inch diameter solid stem truck mounted
 Logged By: PE auger.

Depth (ft.)	Soil Type	Undisturbed	Bulk	Description	Blows / Foot	N ₆₀	Dry Density (pcf)	Moisture Content (%)	Expansion Index	Unconfined Comp. (psf)	Particle Size	Other Tests	
	FILL (CL)			Brown sandy lean CLAY with quartz gravels, hard, slightly moist (FILL) hard	54	25	118.7	12.1		16234			
5	CH			Light brown fat CLAY, hard, slightly moist lenses of calcification hard	60	28	117.3	12.6					
				very stiff	54	49		15.4					
10					58	29							
15	SM			Tan silty SAND, very dense, damp, fine grained sand	50-6"		102.2	21.3					
20	CL			Tan lean CLAY with sand, moist, very stiff, fine grained sand very stiff	24	23		32.8					
25				Boring terminated at a depth of 21 1/2 feet. No groundwater encountered.									
30													
35													

LOG OF EXPLORATORY BORING

Project No.: 12-126-M	Boring: B7 1 of 2	
Project: Monterey County Adult Jail Housing Addition	Location: Reference Boring Site Plan Figure B-2	
	Elevation:	
Date: April 10, 2013	Method of Drilling: Six inch diameter solid stem truck mounted	
Logged By: PE	auger.	

Depth (ft.)	Soil Type	Undisturbed	Bulk	<div style="display: flex; justify-content: space-around; align-items: center;"> <div style="border: 1px solid black; width: 15px; height: 15px; transform: rotate(45deg);"></div> 2" Ring Sample <div style="border: 1px solid black; width: 15px; height: 15px; transform: rotate(-45deg);"></div> 2.5" Ring Sample <div style="border: 1px solid black; width: 15px; height: 15px; transform: rotate(90deg);"></div> Bulk Sample <div style="border: 1px solid black; width: 15px; height: 15px; border-left: none; border-right: none;"></div> Terzaghi Split Spoon Sample <div style="border: 1px solid black; width: 15px; height: 15px; border-left: none; border-right: none; border-bottom: none;"></div> Static Water Table </div>	Blows / Foot	N ₆₀	Dry Density (pcf)	Moisture Content (%)	Expansion Index	Unconfined Comp. (psf)	Particle Size	Other Tests	
												Description	
	CL			4 1/2 " Asphalt Concrete over 5 " Baserock	50-6"		95.2	19.7					
				Light brown sandy lean CLAY, hard, moist, fine grained sand	61	55		17.1					
5				lenses of calcification, very stiff	65	30	104.7	19.9	56	5570			
	CH			Tan fat CLAY, very stiff, moist	43	39		18.6					
10				very stiff	34	18	97.4	18.8					
15	ML			Tan sandy SILT, medium dense, moist, fine grained sand	23	21		21.3					
20	CL			Tan sandy lean CLAY, very stiff, fine grained sand	21	19		28.2					
25				grades to a lean CLAY, moist, very stiff	26	26		39.0					
30				hard	40	42		40.2					
35													

BUTANO GEOTECHNICAL ENGINEERING, INC.

FIGURE
B-10a

LOG OF EXPLORATORY BORING

Project No.: 12-126-M Boring: B7 2 of 2
 Project: Monterey County Adult Jail Housing Addition Location: Reference Boring Site Plan Figure B-2
Elevation:
 Date: April 10, 2013 Method of Drilling: Six inch diameter solid stem truck mounted
 Logged By: PE auger.

Depth (ft.)	Soil Type	Undisturbed	Bulk	<input checked="" type="checkbox"/> 2" Ring Sample <input type="checkbox"/> 2.5" Ring Sample <input checked="" type="checkbox"/> Bulk Sample	Blows / Foot	N ₆₀	Dry Density (pcf)	Moisture Content (%)	Expansion Index	Unconfined Comp. (psf)	Particle Size	Other Tests		
				<input type="checkbox"/> Terzaghi Split Spoon Sample <input type="checkbox"/> Static Water Table										
Description														
35	CH													
40				hard	35	37		36.7						
45	CL			<input checked="" type="checkbox"/> Brown lean CLAY with sand, very dense, saturated <input type="checkbox"/>										
50					28	30		16.6						
55														
60	SC			grades to a tan clayey SAND, very dense	61	67		16.6			✓			
65				Boring terminated at a depth of 61 1/2 feet. Groundwater encountered at a depth of 46 feet.										
70														

LOG OF EXPLORATORY BORING

Project No.: 12-126-M	Boring: B8 1 of 2	
Project: Monterey County Adult Jail Housing Addition	Location: Reference Boring Site Plan Figure B-2	
Date: April 10, 2013	Elevation:	
Logged By: PE	Method of Drilling: Six inch diameter solid stem truck mounted auger.	

Depth (ft.)	Soil Type	Undisturbed	Bulk	Description	Blows / Foot	N ₆₀	Dry Density (pcf)	Moisture Content (%)	Expansion Index	Unconfined Comp. (psf)	Particle Size	Other Tests		
												Swell (psf)		
5	CH	2" Ring Sample 2.5" Ring Sample Bulk Sample		3" Asphalt Concrete over 3" Baserock	33	17	103.4	20.4		4520				
		Terzaghi Split Spoon Sample Static Water Table		Brown fat CLAY, very stiff, moist hard	59	54								
					hard	50-6"	44	109.5	18.0		8053		2015	
					hard	63	57		19.4					
					very stiff	49	25	93.9	25.1					
15	ML			Tan sandy SILT, medium dense, moist, fine grained sand	40	27	99.0	11.2						
20	CL			Light brown lean CLAY, hard, moist hard	40	40		25.6						
25														
30														
35														

LOG OF EXPLORATORY BORING

Project No.: 12-126-M	Boring: B9 1 of 2	
Project: Monterey County Adult Jail Housing Addition	Location: Reference Boring Site Plan Figure B-2	
	Elevation:	
Date: April 10, 2013	Method of Drilling: Six inch diameter solid stem truck mounted auger.	
Logged By: PE		

Depth (ft.)	Soil Type	Undisturbed	Bulk	Description	Blows / Foot	N ₆₀	Dry Density (pcf)	Moisture Content (%)	Expansion Index	Unconfined Comp. (psf)	Particle Size	Other Tests	
	FILL	/		3" Asphalt Concrete over 3" Baserock	61	28	114.0	15.5		7035			
	(CL)			Dark brown sandy lean CLAY with gravel, hard, moist (FILL)									
	CH			Brown fat CLAY with sand, very stiff, slightly moist	26	22		11.7					
5		/		very stiff	42	20	105.0	20.0		4743			
		/						22.8					
10		/		lenses of calcification, very stiff	43	21	94.0	13.6					
15	ML			Tan sandy SILT, very dense, moist, fine grained sand	39	38		32.1					
20	CH			Light brown with red mottling fat CLAY, very stiff, moist	16	14		30.6					
25													
30													
35													





















LOG OF EXPLORATORY BORING

Project No.: 12-126-M	Boring: B9 2 of 2	
Project: Monterey County Adult Jail Housing Addition	Location: Reference Boring Site Plan Figure B-2	
Date: April 10, 2013	Elevation:	
Logged By: PE	Method of Drilling: Six inch diameter solid stem truck mounted auger.	

Depth (ft.)	Soil Type	Undisturbed	Bulk	<div style="display: flex; justify-content: space-around; font-size: small;"> <div style="border: 1px solid black; width: 15px; height: 15px; transform: rotate(45deg);"></div> 2" Ring Sample <div style="border: 1px solid black; width: 15px; height: 15px; transform: rotate(-45deg);"></div> 2.5" Ring Sample <div style="border: 1px solid black; width: 15px; height: 15px; transform: rotate(45deg); border: 2px solid black;"></div> Bulk Sample <div style="border: 1px solid black; width: 15px; height: 15px; border: 2px solid black;"></div> Terzaghi Split Spoon Sample <div style="text-align: center; font-size: x-small;">▽</div> Static Water Table </div>	Blows / Foot	N ₆₀	Dry Density (pcf)	Moisture Content (%)	Expansion Index	Unconfined Comp. (psf)	Particle Size	Other Tests	
												Description	
35	CH			<div style="text-align: center; margin-bottom: 20px;">▽</div>	30	30		30.6					
40													
45	CL			<div style="text-align: center; margin-bottom: 20px;">▽</div>									
50					31	32		19.1					
55													
60				34	36		21.4			✓			
65				Boring terminated at a depth of 61 1/2 feet. Groundwater encountered at a depth of 40 feet.									
70													

LOG OF EXPLORATORY BORING

Project No.: 12-126-M Boring: B10
 Project: Monterey County Adult Jail Housing Addition Location: Reference Boring Site Plan Figure B-2
 Date: April 10, 2013 Elevation:
 Logged By: PE Method of Drilling: Six inch diameter solid stem truck mounted auger.

Depth (ft.)	Soil Type	Undisturbed	Bulk	<div style="display: flex; justify-content: space-around; align-items: flex-start;"> <div style="text-align: center;">  2" Ring Sample  Terzaghi Split Spoon Sample </div> <div style="text-align: center;">  2.5" Ring Sample  Static Water Table </div> <div style="text-align: center;">  Bulk Sample </div> </div>	Blows / Foot	N ₆₀	Dry Density (pcf)	Moisture Content (%)	Expansion Index	Unconfined Comp. (psf)	Swell (psf)	Atterberg Limits		
												L.L.	P.I.	
50-6"	(FILL) CL			4" Asphalt Concrete over 5" Baserock			8.5							
				White and gray gravelly lean CLAY with sand, slightly damp										
	CH			Brown sandy fat CLAY, hard, slightly moist		78	71	9.8						
5				very stiff		55	26	102.1	21.8	78	5379	2270	66.0	47.3
				with lenses of calcification, hard		41	37	19.5						
10				very stiff		49	25	103.3	2.2		3501			
15	ML			Tan sandy SILT, medium dense, moist, fine grained sand		19	17	22.2						
20	ML			Light brown sandy lean CLAY, very stiff, moist		25	24	29.5						
25	Boring terminated at a depth of 21 1/2 feet. No groundwater encountered.													

LOG OF EXPLORATORY BORING

Project No.: 12-126-M Boring: B11
 Project: Monterey County Adult Jail Housing Addition Location: Reference Boring Site Plan Figure B-2
 Date: August 27, 2013 Elevation:
 Logged By: PE Method of Drilling: 3 1/2 inch diameter hand auger.

Depth (ft.)	Soil Type	Undisturbed	Bulk	<div style="display: flex; justify-content: space-around; font-size: 0.8em;"> <div style="text-align: center;"><input checked="" type="checkbox"/> 2" Ring Sample</div> <div style="text-align: center;"><input type="checkbox"/> 2.5" Ring Sample</div> <div style="text-align: center;"><input checked="" type="checkbox"/> Bulk Sample</div> </div> <div style="display: flex; justify-content: space-around; font-size: 0.8em; margin-top: 5px;"> <div style="text-align: center;"><input type="checkbox"/> Terzaghi Split Spoon Sample</div> <div style="text-align: center;"><input type="checkbox"/> Static Water Table</div> </div>	Blows / Foot	N ₆₀	Dry Density (pcf)	Moisture Content (%)	Expansion Index	Unconfined Comp. (psf)	Particle Size	Other Tests	
												Description	
	CL		<input checked="" type="checkbox"/>	3" AC overlay, 1 1/2" original AC, over 6" baserock. Brown lean CLAY, stiff, moist.									
5				Boring terminated at a depth of 4 1/2 feet. No groundwater encountered.									
10													
15													
20													
25													
30													
35													

LOG OF EXPLORATORY BORING

Project No.: 12-126-M Boring: B12
 Project: Monterey County Adult Jail Housing Addition Location: Reference Boring Site Plan Figure B-2
 Elevation:
 Date: August 27, 2013 Method of Drilling: 3 1/2 inch diameter hand auger.
 Logged By: PE

Depth (ft.)	Soil Type	Undisturbed	Bulk	<input checked="" type="checkbox"/> 2" Ring Sample <input type="checkbox"/> 2.5" Ring Sample <input checked="" type="checkbox"/> Bulk Sample <input type="checkbox"/> Terzaghi Split Spoon Sample <input type="checkbox"/> Static Water Table	Blows / Foot	N ₆₀	Dry Density (pcf)	Moisture Content (%)	Expansion Index	Unconfined Comp. (psf)	Particle Size	Other Tests			
												Description			
	SP		<input checked="" type="checkbox"/>	2 3/4" AC overlay, 2 1/2" original AC, over 6" Baserock											
			<input checked="" type="checkbox"/>	Salt and pepper poorly graded SAND with silt and some clay, loose to medium dense, damp.											
	CL		<input checked="" type="checkbox"/>	Dark brown lean CLAY, medium stiff, moist, younger alluvium.											
5				Boring terminated at a depth of 4 1/2 feet. No groundwater encountered.											
10															
15															
20															
25															
30															
35															

LOG OF EXPLORATORY BORING

Project No.: 12-126-M	Boring: B13	
Project: Monterey County Adult Jail Housing Addition	Location: Reference Boring Site Plan Figure B-2	
Date: August 27, 2013	Elevation:	
Logged By: PE	Method of Drilling: 3 1/2 inch diameter hand auger.	

Depth (ft.)	Soil Type	Undisturbed	Bulk	<input checked="" type="checkbox"/> 2" Ring Sample <input type="checkbox"/> 2.5" Ring Sample <input checked="" type="checkbox"/> Bulk Sample	Blows / Foot	N ₆₀	Dry Density (pcf)	Moisture Content (%)	Expansion Index	Unconfined Comp. (psf)	Particle Size	Other Tests		
				<input type="checkbox"/> Terzaghi Split Spoon Sample <input type="checkbox"/> Static Water Table										
Description														
5	CL		<input checked="" type="checkbox"/>	2 1/2" AC overlay, 2 1/4" original AC, over 10" baserock. Grey lean CLAY with trace sand, medium stiff, moist.										
10				Boring terminated at a depth of 4 1/2 feet. No groundwater encountered.										
15														
20														
25														
30														
35														

APPENDIX C

LABORATORY TESTING PROGRAM

Laboratory Testing Procedures	Page C-1
Particle Size Analysis	Figure C-1 through C-4
Atterberg Limits	Figure C-5
Swell Test	Figures C-6 through C-9
R-Value	Figure C-10

LABORATORY TESTING PROCEDURES

Classification

Soils were classified according to the Unified Soil Classification System in accordance with ASTM D 2487 and D 2488. Moisture content and dry density determinations were made for representative, relatively undisturbed samples in accordance with ASTM D 2216. Results of moisture-density determinations, together with classifications, are shown on the Boring Logs, Figures B-4 through B-17.

Particle Size Analysis

Four sieves were performed on representative samples in accordance with ASTM D 422. The grain size distributions from the result of the particle size analysis are presented in Figures C-1 through C-4.

Atterberg Limits

Two Atterberg limit tests were performed in accordance with ASTM D-4318. The results are presented in Figures C-5 and shown on the boring logs Figures B-5 and B-13.

Expansion Index

Eight expansion index tests were performed on representative bulk samples of the foundation zone soil in accordance with ASTM D 4829-03. The results are shown on the Boring Logs, Figures B-4 through B-17.

Swell Test

Four one-dimensional swell tests were performed on representative relatively undisturbed samples in accordance with ASTM D-4546. The results are presented in Figures C-6 through C-9 and shown on the boring logs Figures B-4 through B-17.

Unconfined Compression

17 unconfined compression tests were performed in accordance with ASTM D 2166. The results are shown on the boring logs Figures B-4 through B-17.

R-Value

One R-Value test was performed on a bulk sample of the pavement subgrade from borings B14. The tests were performed in accordance with CALTRANS test 301. The test results are presented in Figure C-10 and shown on the boring log Figure B-17.

BORING:	B1-5	PERCENT	PERCENT
DEPTH (ft):	15.0	PASSING No. 4	PASSING No. 200
SOIL TYPE (USCS):	ML (Sandy Silt)	100.0%	59.5%

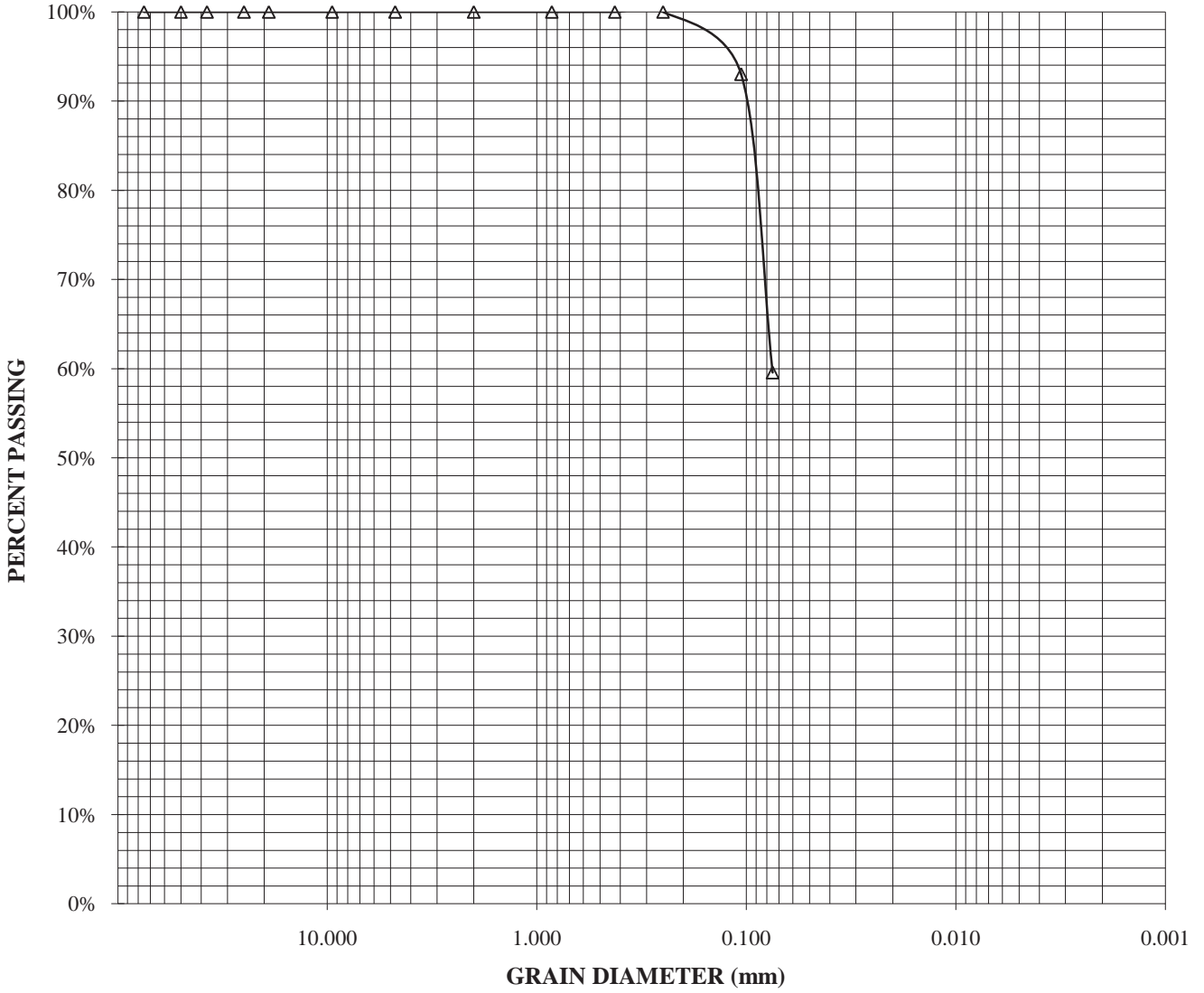

BUTANO
 GEOTECHNICAL ENGINEERING, INC.

GRAIN SIZE DISTRIBUTION
 Monterey County Adult Jail Housing Addition

FIGURE
 C-1

BORING:	B7-12	PERCENT	PERCENT
DEPTH (ft):	60	PASSING No. 4	PASSING No. 200
SOIL TYPE (USCS):	SC (Clayey Sand)	99.0%	35.8%

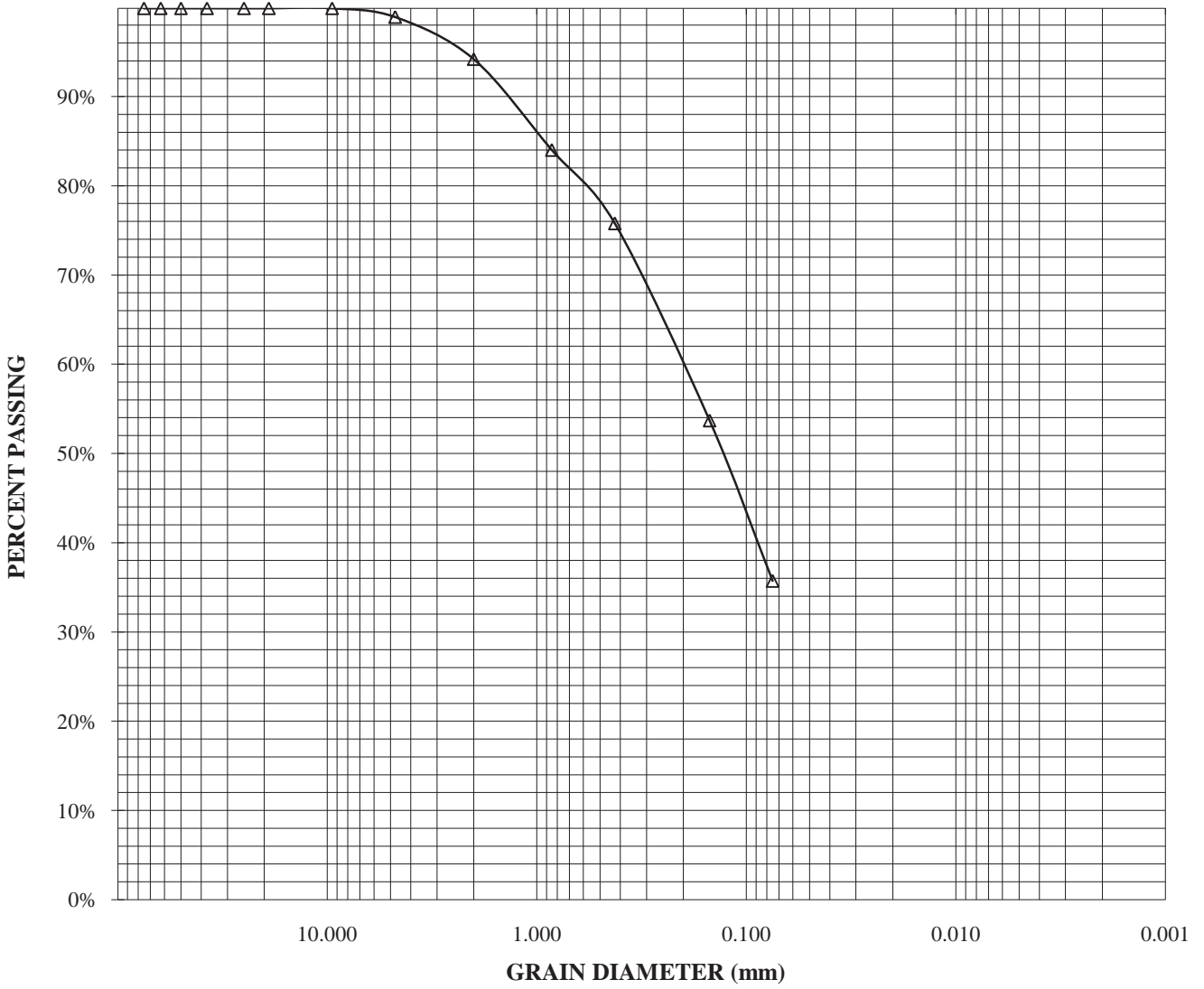

BUTANO
 GEOTECHNICAL ENGINEERING, INC.

GRAIN SIZE DISTRIBUTION
 Monterey County Adult Jail Housing Addition

FIGURE
 C-2

BORING:	B8-10	PERCENT	PERCENT
DEPTH (ft):	60.0	PASSING No. 4	PASSING No. 200
SOIL TYPE (USCS):	CH (Sandy Fat Clay)	99.7%	68.7%

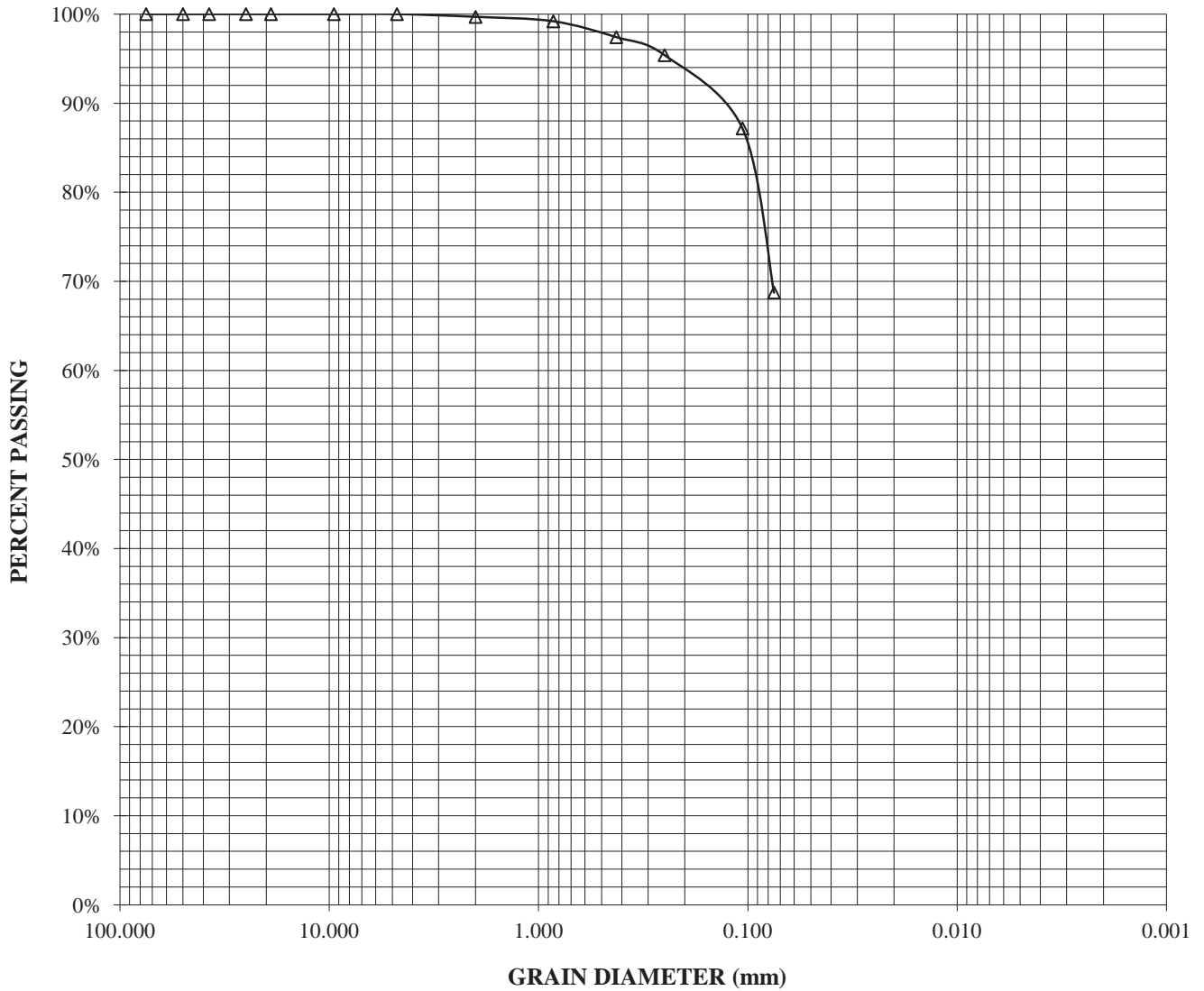

BUTANO
 GEOTECHNICAL ENGINEERING, INC.

GRAIN SIZE DISTRIBUTION
 Monterey County Adult Jail Housing Addition

FIGURE
 C-3

BORING:	B9-9	PERCENT	PERCENT
DEPTH (ft):	60	PASSING No. 4	PASSING No. 200
SOIL TYPE (USCS):	CH (Fat Clay with Sand)	100.0%	71.3%

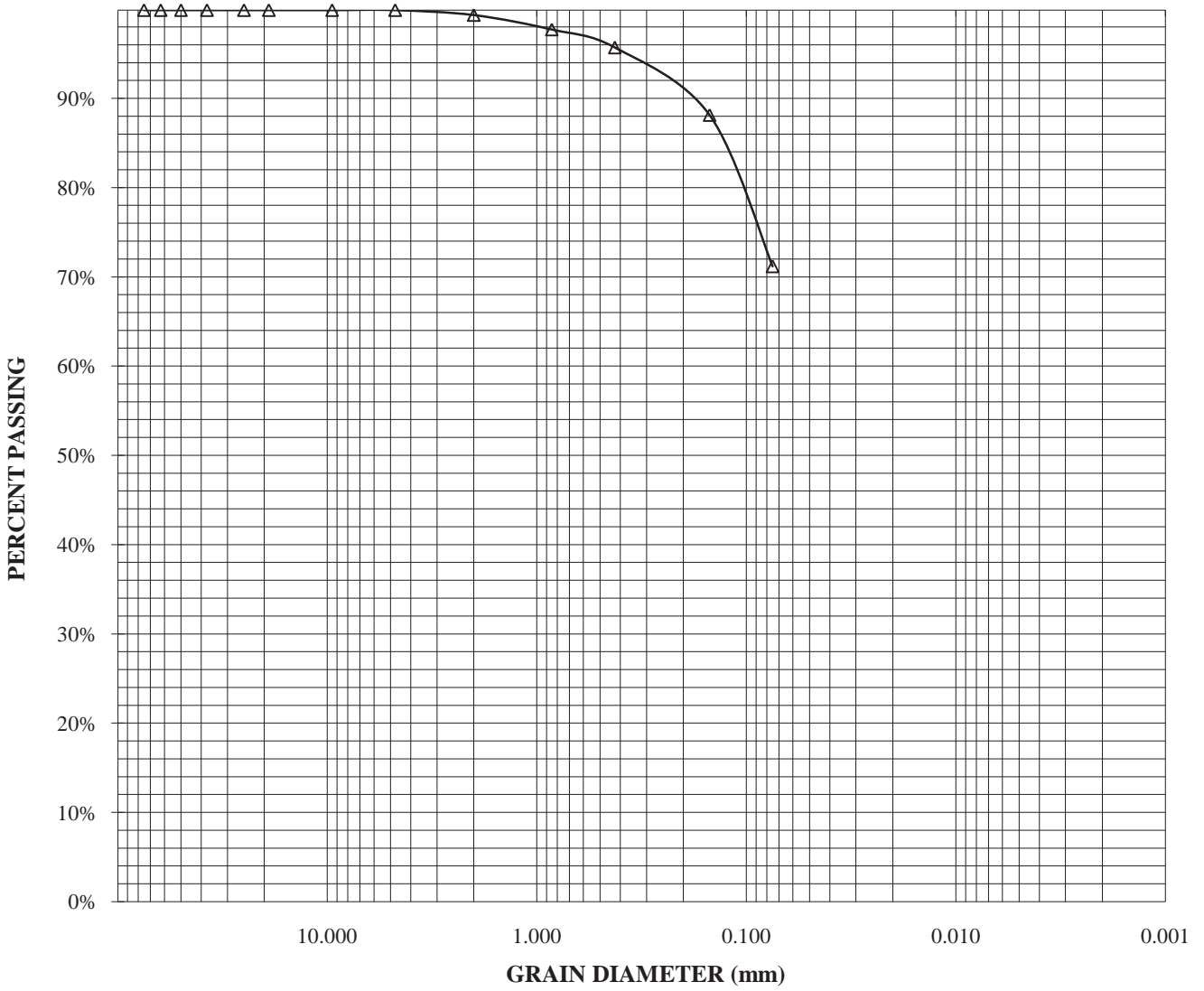

BUTANO
 GEOTECHNICAL ENGINEERING, INC.

GRAIN SIZE DISTRIBUTION
 Monterey County Adult Jail Housing Addition

FIGURE
 C-4

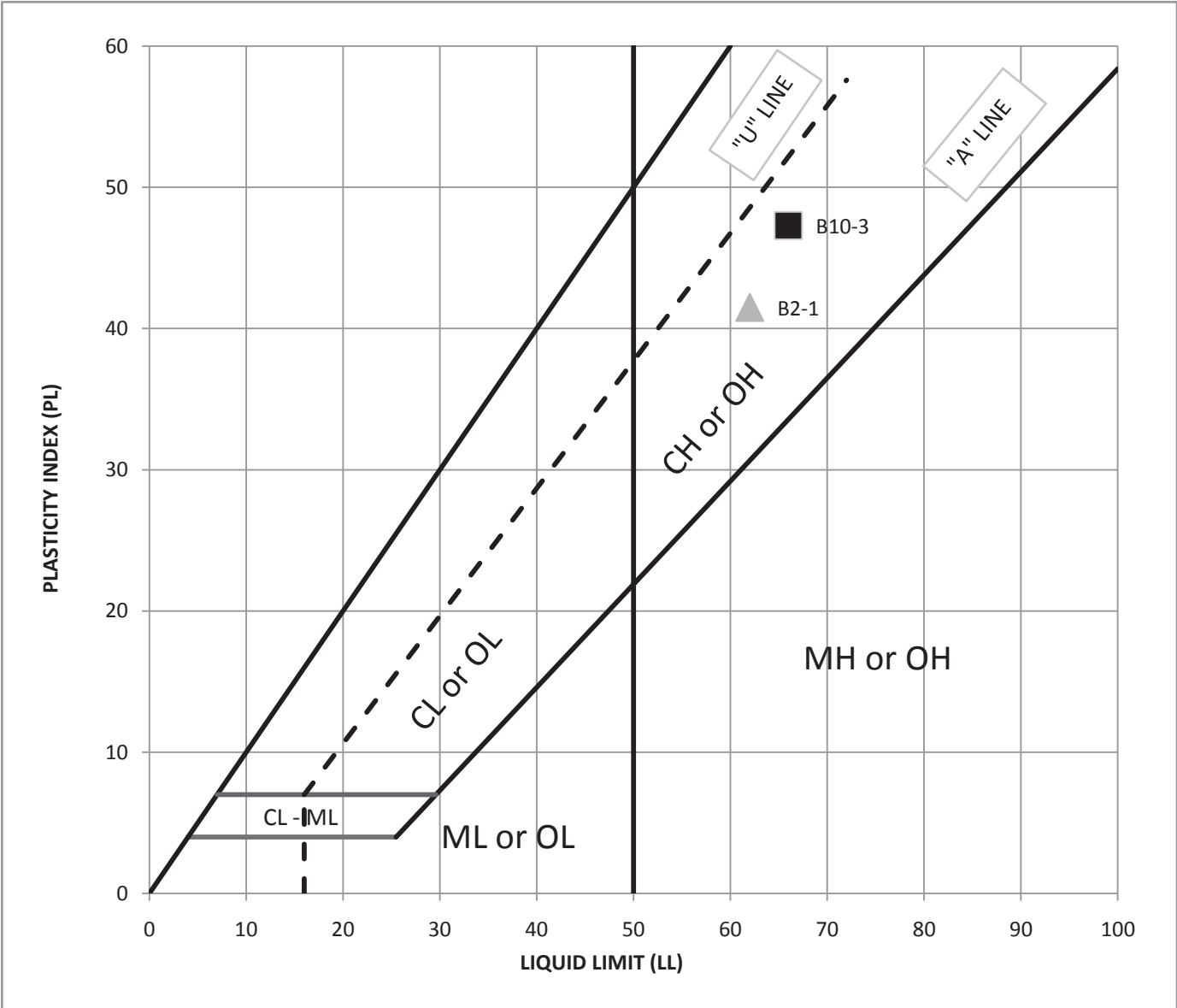

BORING:	B2-1		
DEPTH (ft):	1.0		
SOIL TYPE (USCS):	CH	FIELD MOISTURE:	23.4%
		FINAL MOISTURE:	23.3%

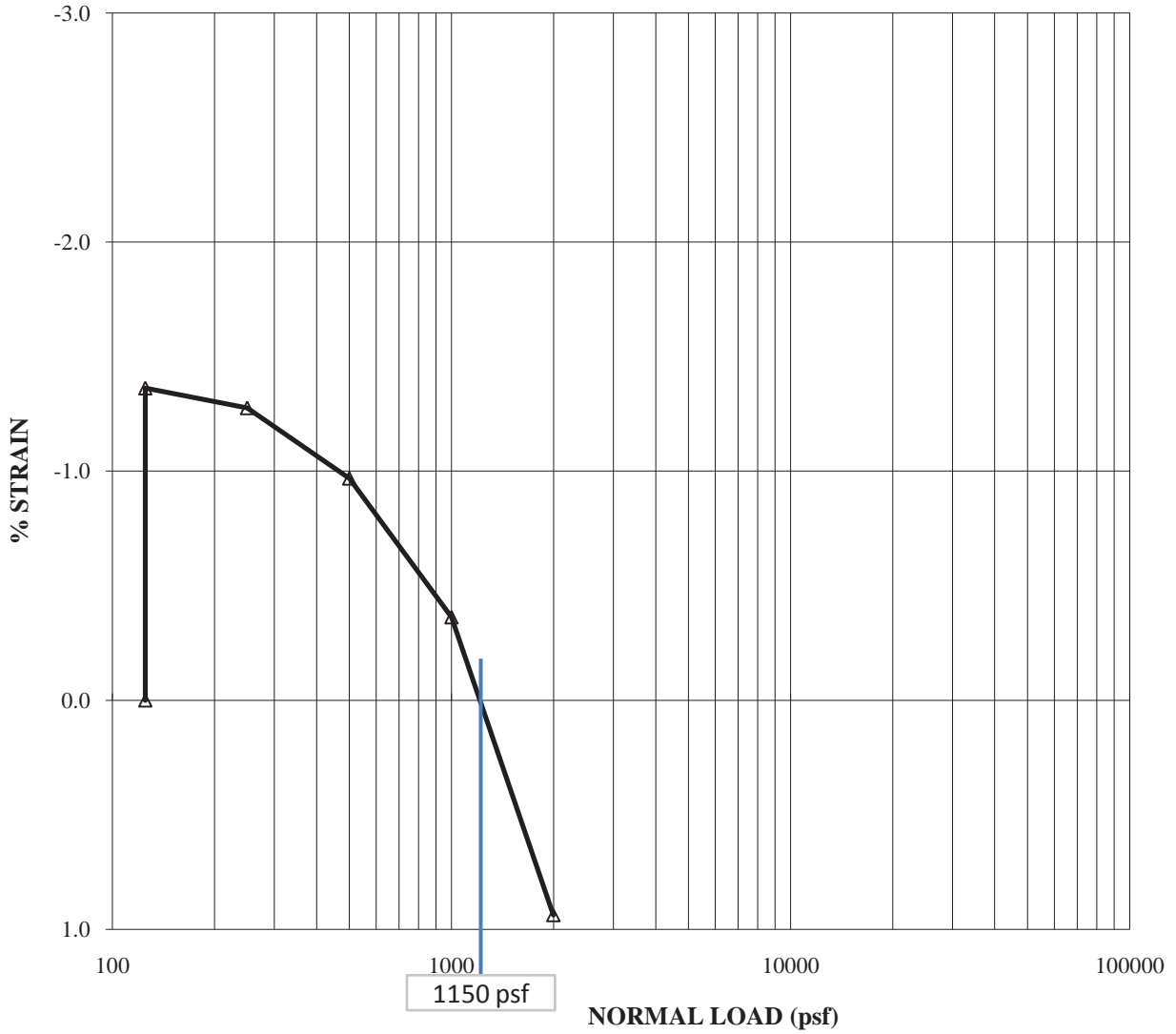

BUTANO GEOTECHNICAL ENGINEERING, INC.	SWELL TEST RESULTS	FIGURE C-6
	Monterey County Adult Jail Housing Addition	

BORING:	B3-1		
DEPTH (ft):	1.0		
SOIL TYPE (USCS):	CH	FIELD MOISTURE:	10.7%
		FINAL MOISTURE:	16.6%

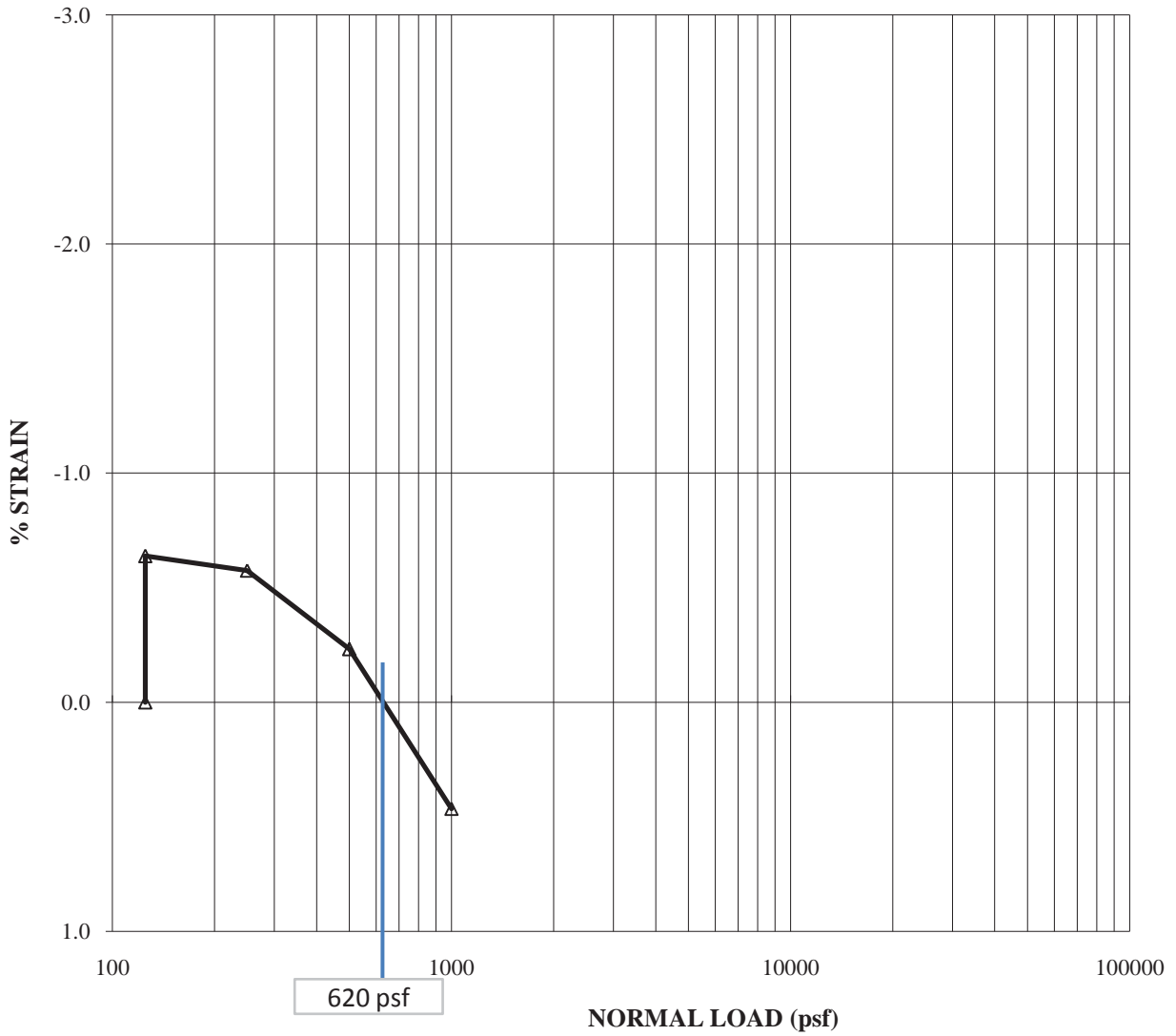

BUTANO GEOTECHNICAL ENGINEERING, INC.	SWELL TEST RESULTS	FIGURE
	Monterey County Adult Jail Housing Addition	C-7

BORING:	B8-3		
DEPTH (ft):	5.0		
SOIL TYPE (USCS):	CH	FIELD MOISTURE:	18.0%
		FINAL MOISTURE:	20.7%

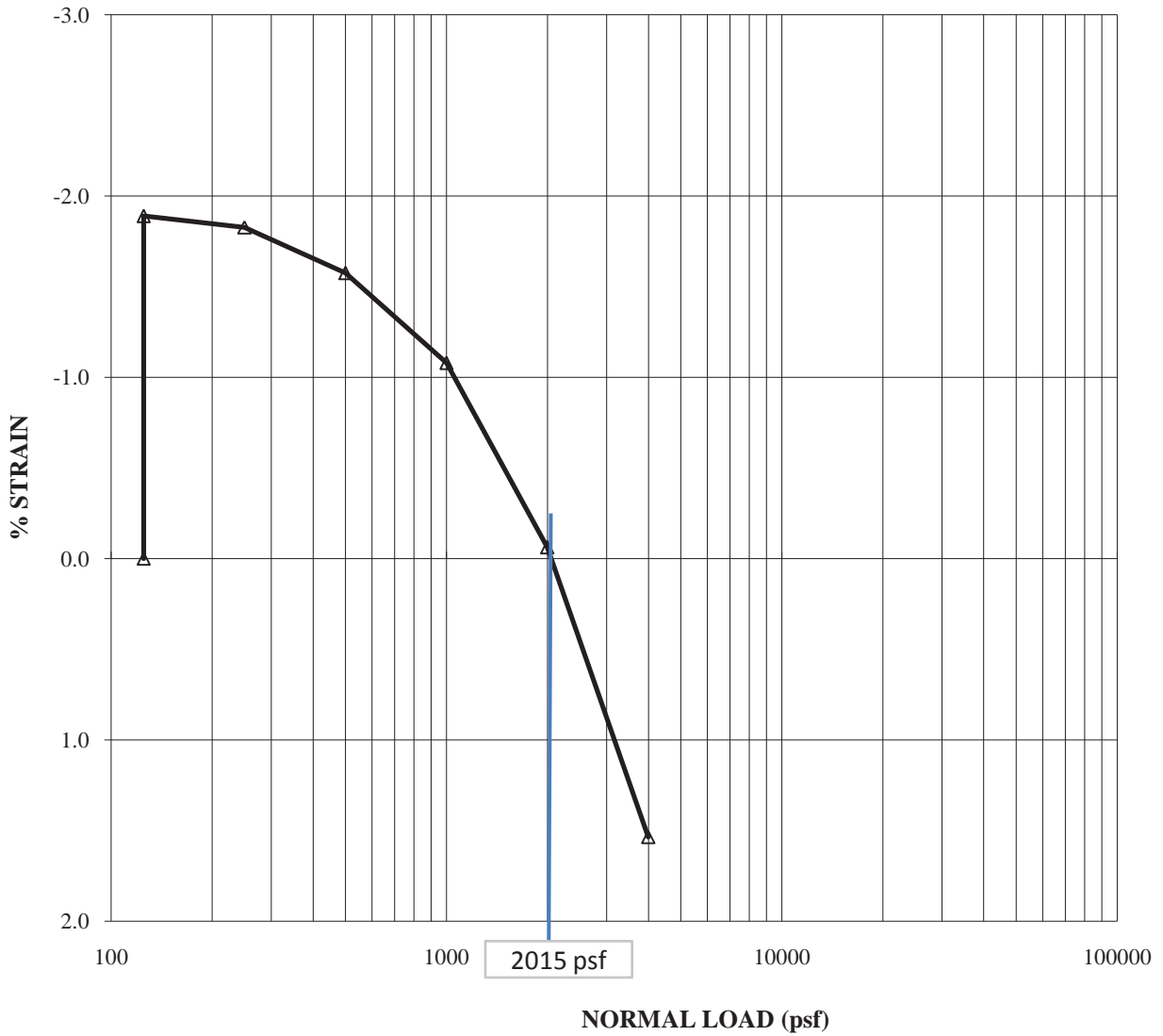

BUTANO GEOTECHNICAL ENGINEERING, INC.	SWELL TEST RESULTS	FIGURE C-8
	Monterey County Adult Jail Housing Addition	

BORING:	B10-3		
DEPTH (ft):	5.0		
SOIL TYPE (USCS):	CH	FIELD MOISTURE:	21.8%
		FINAL MOISTURE:	23.3%

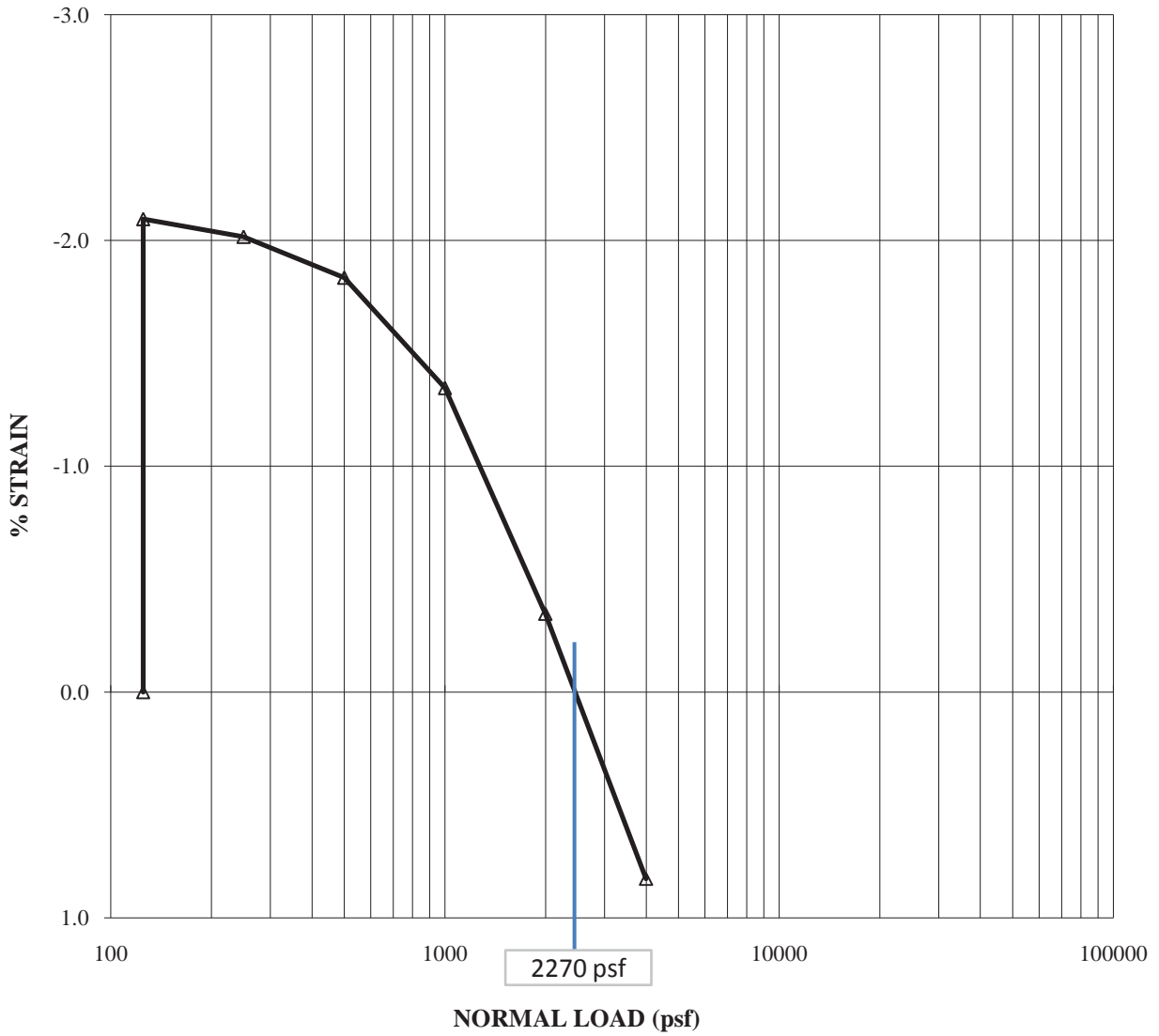

BUTANO GEOTECHNICAL ENGINEERING, INC.	SWELL TEST RESULTS	FIGURE C-9
	Monterey County Adult Jail Housing Addition	

Job No.: 673-007	Date: 09/05/13	Initial Moisture,	17.2%
Client: Butano Geotechnical - 12-126-M	Tested MD	R-value by Stabilometer	<5
Project: Monterey County Adult Jail Housing Addition	Reduced RU	Expansion Pressure	psf
Sample B-14 Chaparal near Natividad, 2-4 feet	Checked DC	Remarks:	
Soil Type: Orange brown sandy lean CLAY			
Specimen Number	A	B	C
Exudation Pressure, psi	196		
Prepared Weight, grams	1200		
Final Water Added, grams/cc	129		
Weight of Soil & Mold, grams	3009		
Weight of Mold, grams	2064		
Height After Compaction, in.	2.43		
Moisture Content, %	29.8		
Dry Density, pcf	90.7		
Expansion Pressure, psf	21.5		
Stabilometer @ 1000			
Stabilometer @ 2000	159		
Turns Displacement	2.93		
R-value	1		

Soil extruded from the mold giving a false exudation pressure. Per Caltrans, the R-Value test was terminated and an R-Value of less than 5 was reported.

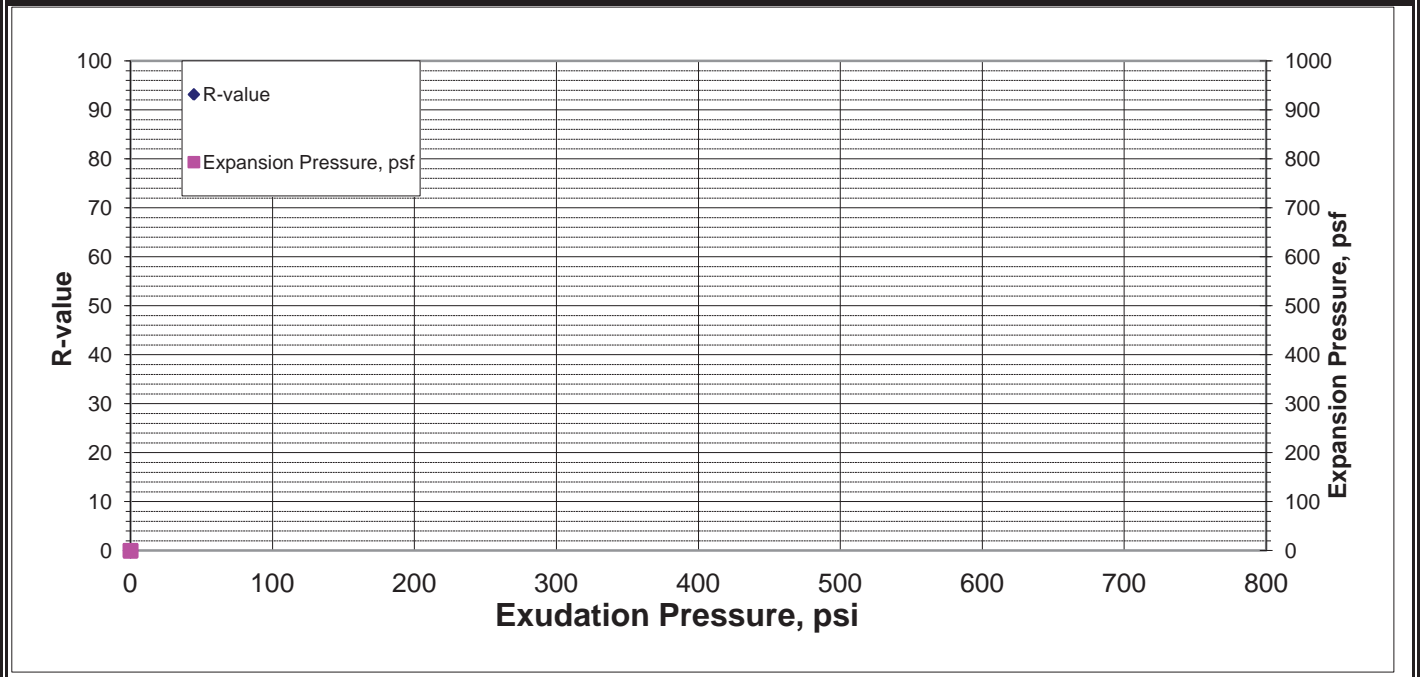

APPENDIX D

PAVEMENT DEFLECTION ANALYSIS

DEFLECTION ANALYSIS
for
MONTEREY COUNTY ADULT JAIL
HOUSING ADDITION
CHAPARRAL STREET ENTRANCE ROAD
SALINAS, CALIFORNIA



Pavement Engineering Inc.



Pavement Engineering Inc.

Civil Engineering • Landscape Architecture
CalTrans/AMRL QC/QA • Construction Management

October 11, 2013

Project No. 130091-02

Mr. Greg Bloom
Butano Geotechnical Engineering Inc.
231 Green Valley Road, Suite E
Freedom, CA 95019

Subject: Pavement Deflection and Structural Analysis for Monterey County Adult Jail Housing Addition - Chaparral Street Entrance from Natividad Road to the Parking Area

Dear Greg:

In accordance with your request, we have completed the deflection testing and structural analysis of the subject project and are herein providing our findings and recommendations.

Introduction

PEI evaluated the Chaparral Street Entrance Road at the Monterey County Adult Jail Housing Addition from Natividad Road to the Parking Lot located in the City of Salinas. Our services included analyzing the existing pavement in general conformance with CTM 356 and a visual condition survey. The traffic indexes and existing pavement thicknesses for this analysis were provided by Butano Geotechnical Engineering.

Included with this report are several appendices that can be referred to while reviewing this report. They include Dynaflect Data sheets and project photographs.

Pavement Analysis

The pavement was divided into three sections based on different pavement condition and traffic loading. The sections are Natividad Road to the Perimeter Drive, Perimeter Drive to Parking Area and Parking Area to Proposed Housing Area. Each section will be analyzed independently.

Natividad Road to Perimeter Drive

The pavement from the Natividad Road to the Perimeter Drive exhibits extensive alligator cracking with some of the alligator cracking progressing to base failure. The pavement surface is moderately to severely raveled. The design traffic is 7.0 for this section of pavement based on city bus usage.

Perimeter Drive to Parking Area

The pavement from the Perimeter Drive to the Parking Area exhibits moderate to severe raveling and random shrinkage cracking. The design traffic index for this section of pavement is 5.5.

Parking Area to Proposed Housing Area

The pavement from the Parking Area to the Proposed Housing Area has been previously seal coated. The seal coat is in poor condition. The design traffic index for this section is 5.5.

The existing pavement thickness at Butano Geotechnical Engineering's boring locations consisted of 2 to 5.25 inches of asphalt concrete over 6 to 10 inches of aggregate base. The general section is approximately 5 inches of asphalt concrete over 6 inches of aggregate base.

The native soils are brown clays with an R-value of less than 5.

Based on the deflection analysis, the pavement from Natividad Road to the Perimeter Drive is structurally deficient by 1-1/2 inches of HMA for a traffic index of 7.0. The other two sections of pavement are showing slight deficiency by up to 1/2 inch of HMA.

Recommendations

Natividad Road to Perimeter Drive

The pavement from Natividad Road to the Perimeter Drive is structurally deficient by 1-1/2 structural inches based on the deflection analysis. We are providing two recommendations for resurfacing and two recommendations for reconstruction. Reconstruction should be considered if base failures exceed 7 percent of the pavement area.

For alternate 1 resurfacing, we recommend 5 inch pavement digouts of base failure, and placing a 1-3/4 inch HMA overlay. The estimated design life for this alternative is 8 to 12 years. The approximate cost for this alternative is \$2.65/sf.

For alternate 2 resurfacing, we recommend 5 inch digouts of base failures, placing a 1/2 inch HMA leveling course and placing a 1-3/4 inch RHMA overlay. The estimated design life for this alternative is 8 to 12 years. The approximate cost for this alternative is \$3.00/sf.

For alternate 3 reconstruction, we recommend removing the pavement to a depth of 11 inches and placing 11 inches of new HMA in 4 lifts. The estimated design life for this alternative is 15 to 20 years. The approximate cost for this alternative is \$7.50/sf.

For alternate 4 reconstruction, we recommend removing the existing pavement to a depth of 5 inches, treating the existing aggregate base mixed with native soil to a depth of 12-1/2 inches with a lime plus additive and placing 5 inches of new HMA in 2 lifts. The estimated design life for this alternative is 15 to 20 years. The approximate cost for this alternative is \$5.25/sf.



Perimeter Drive to Parking Area

The pavement from the Perimeter Drive to the Parking Area is slightly structurally deficient, however, the cracking is minimal. We are providing one alternative for maintenance and 2 alternatives for resurfacing. Resurfacing may be desired to match the pavement from Natividad Road to the Perimeter Drive, if an overlay is placed on that section.

For alternate 1 maintenance, we recommend crack filling, 5 inch pavement digouts of base failures and seal coating the pavement. The estimated design life for this alternative is 3 to 5 years. The approximate cost for this alternative is \$0.40/sf.

For alternate 2 overlay, we recommend a 1-3/4 inch HMA overlay. The estimated design life for this alternative is 8 to 12 years. The approximate cost for this alternative is \$2.00/sf.

For alternate 3 overlay, we recommend placing a 1-3/4 inch RHMA overlay. The estimated design life for this alternative is 8 to 12 years. The approximate cost for this alternative is \$2.50/sf.

Parking Area to Proposed Housing Area

The analysis of the pavement from the Parking Area to the Proposed Housing Area shows slight structural deficiency and minimal cracking. We are providing one alternative for maintenance and 2 alternatives for resurfacing. Resurfacing is recommended if there is a desire to match the overlays of the other pavement areas.

For alternate 1 maintenance, we recommend crack filling and seal coating the pavement. The estimated design life for this alternative is 3 to 5 years. The approximate cost for this alternative is \$0.30/sf.

For alternate 2 overlay, we recommend placing a 1-3/4 inch HMA overlay. The estimated design life for this alternative is 8 to 12 years. The approximate cost for this alternative is \$2.00/sf.

For alternate 3 overlay, we recommend placing a 1-3/4 inch RHMA overlay. The estimated design life for this alternative is 8 to 12 years. The approximate cost for this alternative is \$2.50/sf.

Limitations

This report has been prepared on the basis of the indicated field testing and application of our knowledge of pavement technology. The repair strategies in this report are based upon industry standards. The overlays have been designed in general conformance with California Test Method 356.

Mr. Greg Bloom
October 11, 2013
130091-02
Page 4

The report contains projections of future life. These are given to provide a broad outline for pavement maintenance budgeting. They should not be interpreted as providing definitive predictions of future pavement performance.

Our professional services were performed, findings obtained, and recommendations prepared in accordance with generally accepted engineering principles and practices. No warranty is either expressed or implied.

Summary

We have completed the deflection analysis for the Chaparral Street Entrance at the Monterey County Jail from Natividad Road to the Proposed Housing Area. For the section from Natividad Road to the Perimeter Drive, we have provided two alternatives for resurfacing and two alternatives for reconstruction. For the pavement from the Perimeter Drive to the Proposed Housing Area, we have provided one alternative for maintenance and two alternatives for resurfacing.

If you have any questions, please do not hesitate to give me a call at (530) 224-4535.

Very truly yours,
PAVEMENT ENGINEERING INC.



William J. Long, P.E.
Principal Engineer

Attachments: Dynaflect Data
 Photo Log
 Photographs

pc: C File
 130091-02



PAVEMENT ENGINEERING INCORPORATED

Redding

Petaluma

San Luis Obispo

(530) 224-4535

(707) 769-5330

(805) 781-2265

09/12/13

Page 1

Butano Geotechnical

Road: North Entrance Road Survey Date: 08/26/13
From: Nativdad Thickness: 0.42
To: Perimeter Drive Traffic Index: 7.00
Lane/Line: Project Number: 130091-02

Deflection Data Analysis

Deflection Readings (Equivalent Deflectometer Units)

No. of Tests	Low	Mean	High	Std. Dev.
5	26.50	29.04	32.85	2.50

Road Surface

Thickness	Traffic Index
0.42	7.00

Structural Design

Tolerable	80th Percentile	90th Percentile	% Reduction	GE Deficient
22.00	31.14	32.24	29.35	0.23

HMA Overlay
0.12



PAVEMENT ENGINEERING INCORPORATED

Redding

Petaluma

San Luis Obispo

(530) 224-4535

(707) 769-5330

(805) 781-2265

09/12/13

Page 2

Butano Geotechnical

Road: North Entrance Road
From: Nativdad
To: Perimeter Drive
Lane/Line:

Survey Date: 08/26/13
Thickness: 0.42
Traffic Index: 7.00
Project Number: 130091-02

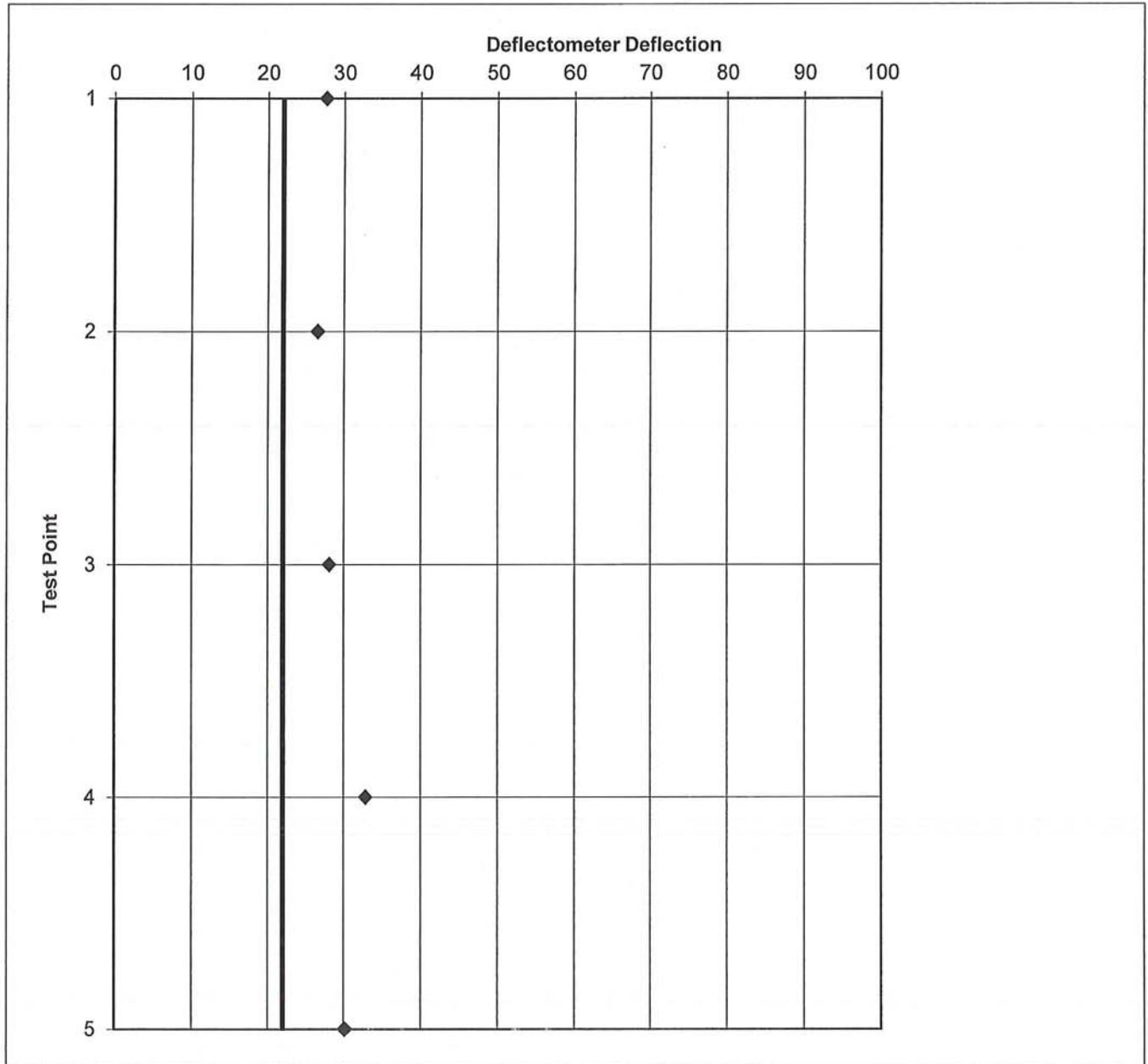

PAVEMENT ENGINEERING INCORPORATED

Redding

Petaluma

San Luis Obispo

(530) 224-4535

(707) 769-5330

(805) 781-2265

09/12/13

Page 1

Butano Geotechnical

Road:	North Entrance Road	Survey Date:	08/26/13
From:	Nativdad	Thickness:	0.25
To:	Parking Area	Traffic Index:	5.50
Lane/Line:		Project Number:	130091-02

Deflection Data Analysis

Deflection Readings (Equivalent Deflectometer Units)

No. of Tests	Low	Mean	High	Std. Dev.
13	14.93	24.91	37.39	5.92

Road Surface

Thickness	Traffic Index
0.25	5.50

Structural Design

Tolerable	80th Percentile	90th Percentile	% Reduction	GE Deficient
40.00	29.89	32.49	0.00	0.00

HMA Overlay
0.00



PAVEMENT ENGINEERING INCORPORATED

Redding
(530) 224-4535

Petaluma
(707) 769-5330

San Luis Obispo
(805) 781-2265

09/12/13

Page 2

Butano Geotechnical

Road: North Entrance Road
From: Nativdad
To: Parking Area
Lane/Line:

Survey Date: 08/26/13
Thickness: 0.25
Traffic Index: 5.50
Project Number: 130091-02

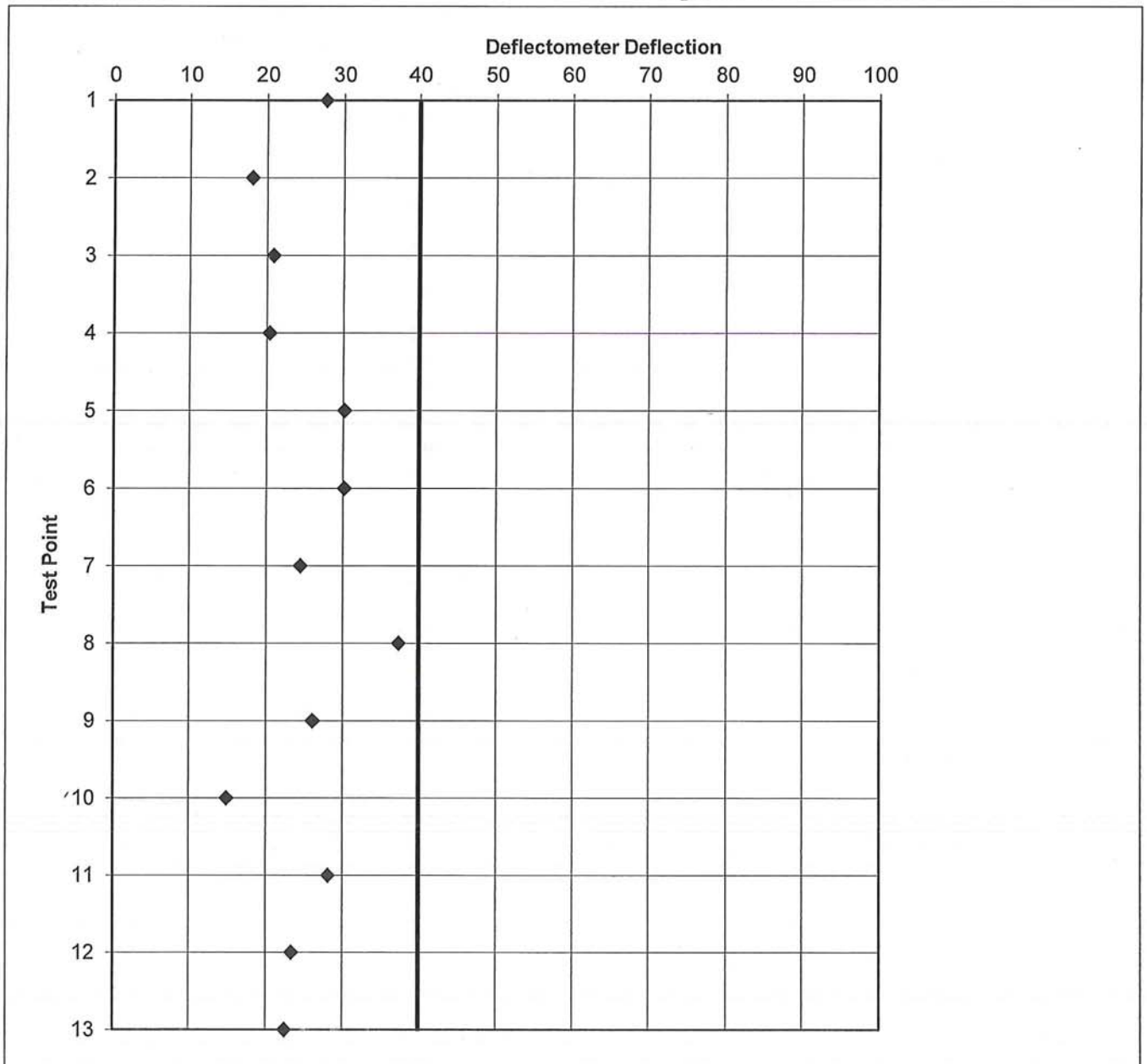

PAVEMENT ENGINEERING INCORPORATED

Redding

Petaluma

San Luis Obispo

(530) 224-4535

(707) 769-5330

(805) 781-2265

09/12/13

Page 1

Butano Geotechnical

Road:	North Entrance Road	Survey Date:	08/26/13
From:	Parking Area	Thickness:	0.42
To:	Perimeter Drive	Traffic Index:	5.50
Lane/Line:		Project Number:	130091-02

Deflection Data Analysis

Deflection Readings (Equivalent Deflectometer Units)

No. of Tests	Low	Mean	High	Std. Dev.
5	19.69	22.46	26.72	2.67

Road Surface

Thickness	Traffic Index
0.42	5.50

Structural Design

Tolerable	80th Percentile	90th Percentile	% Reduction	GE Deficient
31.00	24.70	25.88	0.00	0.00

HMA Overlay
0.00



PAVEMENT ENGINEERING INCORPORATED

Redding

Petaluma

San Luis Obispo

(530) 224-4535

(707) 769-5330

(805) 781-2265

09/12/13

Page 2

Butano Geotechnical

Road: North Entrance Road

Survey Date: 08/26/13

From: Parking Area

Thickness: 0.42

To: Perimeter Drive

Traffic Index: 5.50

Lane/Line:

Project Number: 130091-02

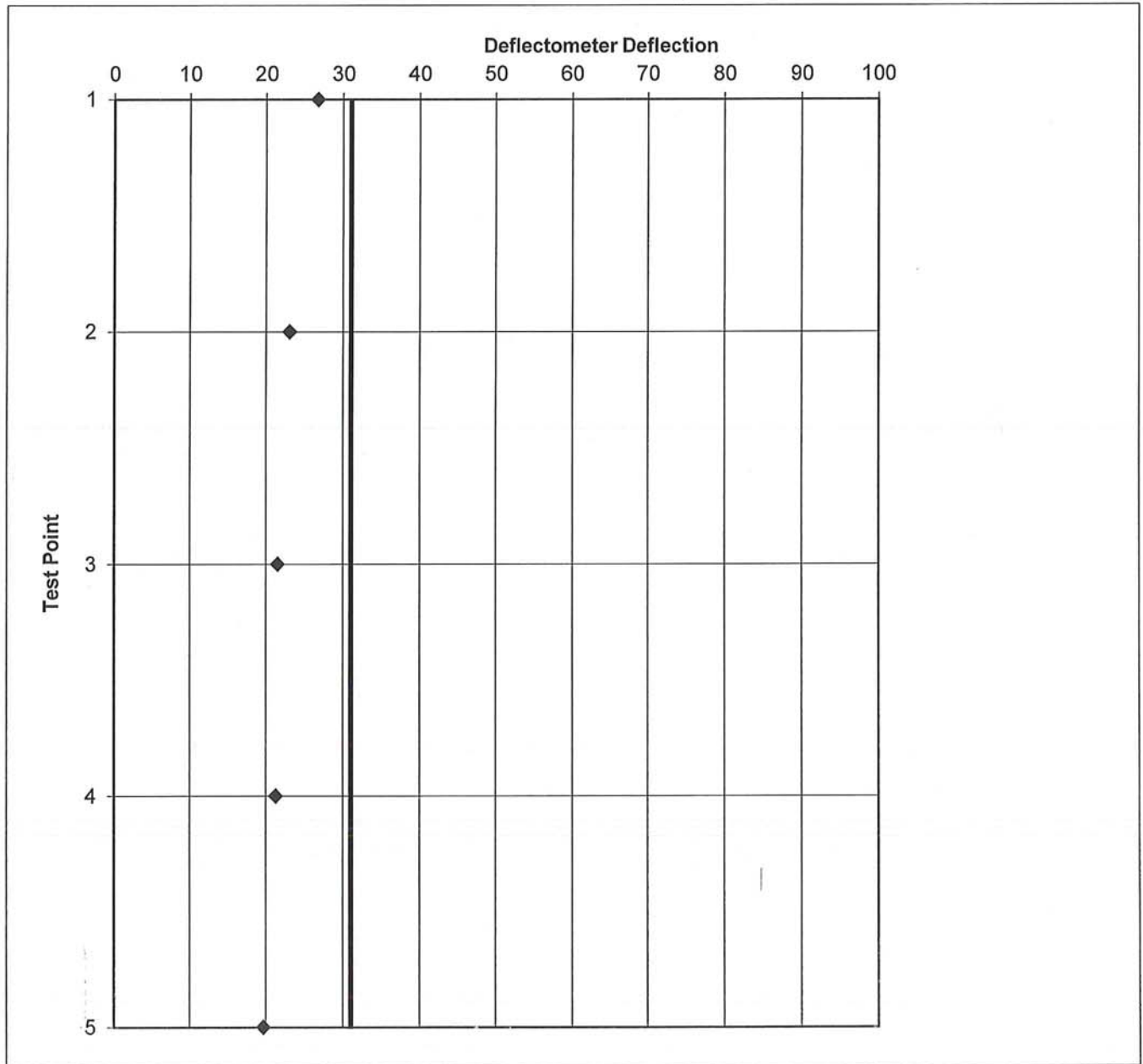

PAVEMENT ENGINEERING INCORPORATED

Redding

Petaluma

San Luis Obispo

(530) 224-4535

(707) 769-5330

(805) 781-2265

09/12/13

Page 1

Butano Geotechnical

Road: North Entrance Road Survey Date: 08/26/13
From: Parking Area Thickness: 0.42
To: Proposed Housing Area Traffic Index: 5.50
Lane/Line: Project Number: 130091-02

Deflection Data Analysis

Deflection Readings (Equivalent Deflectometer Units)

No. of Tests	Low	Mean	High	Std. Dev.
5	19.01	22.59	28.09	3.52

Road Surface

Thickness	Traffic Index
0.42	5.50

Structural Design

Tolerable	80th Percentile	90th Percentile	% Reduction	GE Deficient
31.00	25.55	27.10	0.00	0.00

HMA Overlay
0.00



PAVEMENT ENGINEERING INCORPORATED

Redding

Petaluma

San Luis Obispo

(530) 224-4535

(707) 769-5330

(805) 781-2265

09/12/13

Page 2

Butano Geotechnical

Road: North Entrance Road
From: Parking Area
To: Proposed Housing Area
Lane/Line:

Survey Date: 08/26/13
Thickness: 0.42
Traffic Index: 5.50
Project Number: 130091-02

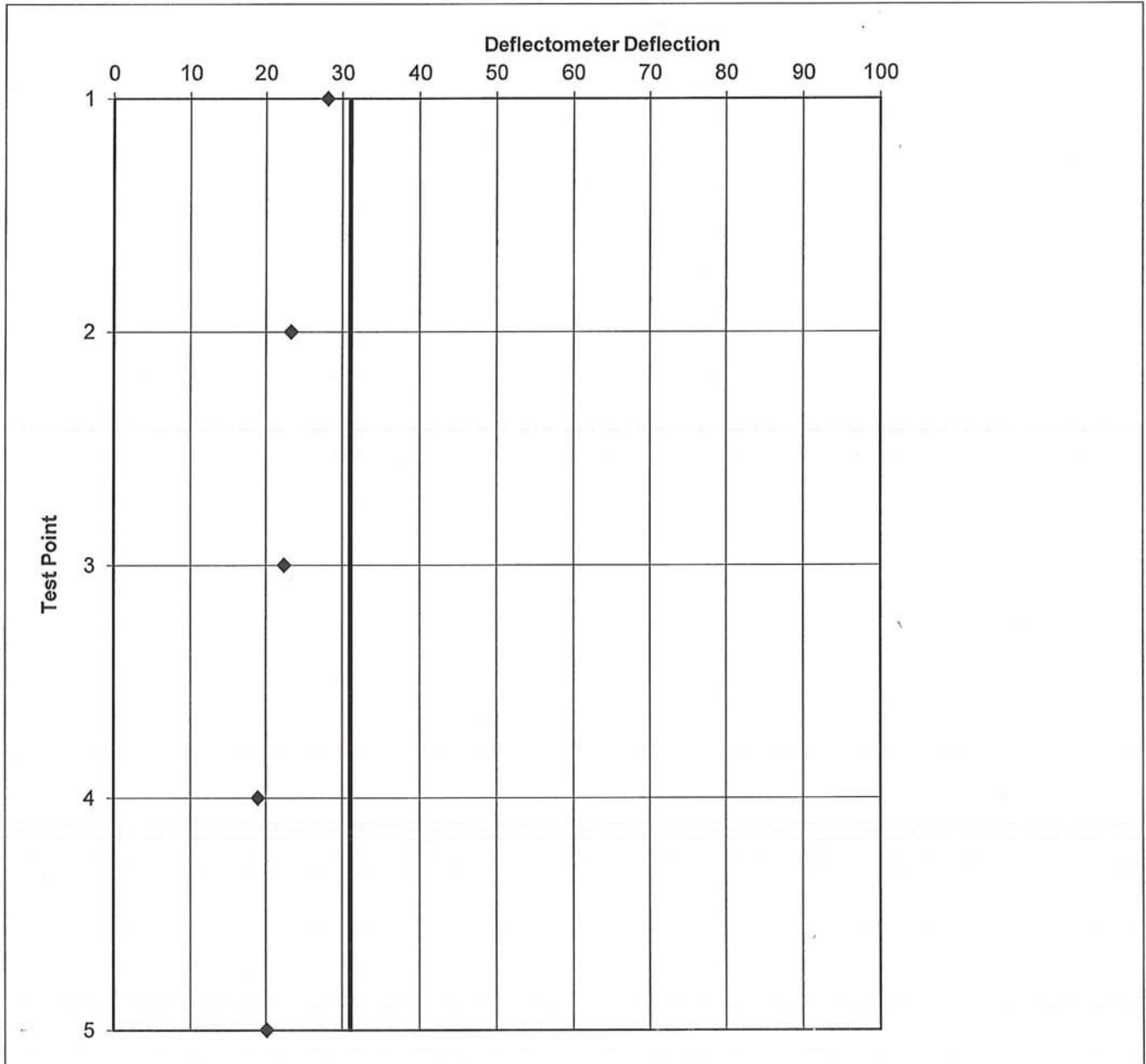

PAVEMENT ENGINEERING INCORPORATED

Redding

Petaluma

San Luis Obispo

(530) 224-4535

(707) 769-5330

(805) 781-2265

09/12/13

Page 1

Butano Geotechnical

Road: North Entrance Road Survey Date: 08/26/13
From: Parking Area Thickness: 0.25
To: Nativdad Traffic Index: 5.50
Lane/Line: Project Number: 130091-02

Deflection Data Analysis

Deflection Readings (Equivalent Deflectometer Units)

No. of Tests	Low	Mean	High	Std. Dev.
13	18.78	26.04	38.52	7.26

Road Surface

Thickness	Traffic Index
0.25	5.50

Structural Design

Tolerable	80th Percentile	90th Percentile	% Reduction	GE Deficient
40.00	32.14	35.33	0.00	0.00

HMA Overlay
0.00



PAVEMENT ENGINEERING INCORPORATED

Redding

Petaluma

San Luis Obispo

(530) 224-4535

(707) 769-5330

(805) 781-2265

09/12/13

Page 2

Butano Geotechnical

Road: North Entrance Road
From: Parking Area
To: Nativdad
Lane/Line:

Survey Date: 08/26/13
Thickness: 0.25
Traffic Index: 5.50
Project Number: 130091-02

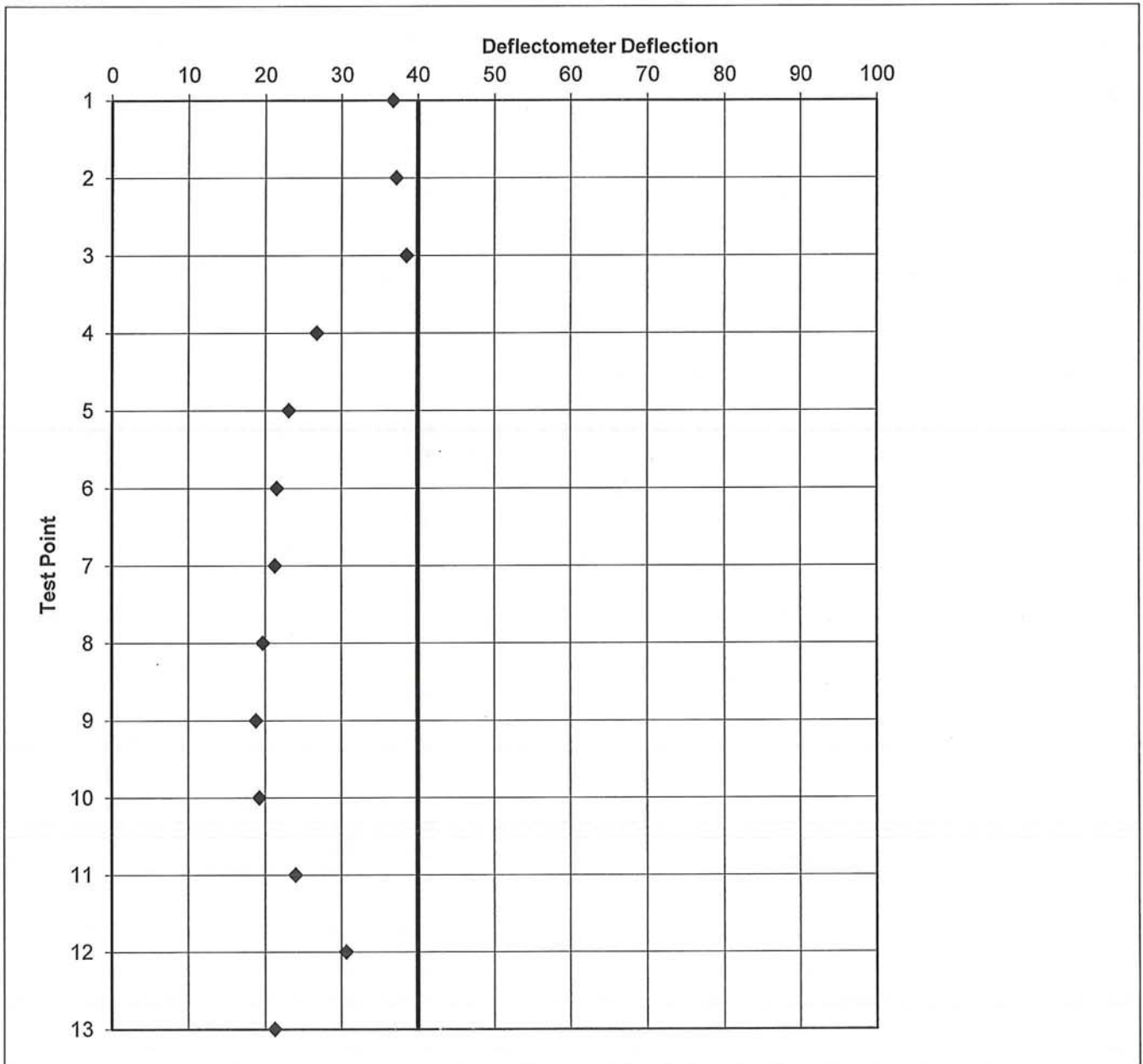

PAVEMENT ENGINEERING INCORPORATED

Redding

Petaluma

San Luis Obispo

(530) 224-4535

(707) 769-5330

(805) 781-2265

09/12/13

Page 1

Butano Geotechnical

Road:	North Entrance Road	Survey Date:	08/26/13
From:	Perimeter Drive	Thickness:	0.42
To:	Natividad	Traffic Index:	7.00
Lane/Line:		Project Number:	130091-02

Deflection Data Analysis

Deflection Readings (Equivalent Deflectometer Units)

No. of Tests	Low	Mean	High	Std. Dev.
5	21.28	25.95	30.58	3.52

Road Surface

Thickness	Traffic Index
0.42	7.00

Structural Design

Tolerable	80th Percentile	90th Percentile	% Reduction	GE Deficient
22.00	28.91	30.45	23.89	0.16

HMA Overlay
0.08



PAVEMENT ENGINEERING INCORPORATED

Redding

Petaluma

San Luis Obispo

(530) 224-4535

(707) 769-5330

(805) 781-2265

09/12/13

Page 2

Butano Geotechnical

Road: North Entrance Road
From: Perimeter Drive
To: Natividad
Lane/Line:

Survey Date: 08/26/13
Thickness: 0.42
Traffic Index: 7.00
Project Number: 130091-02

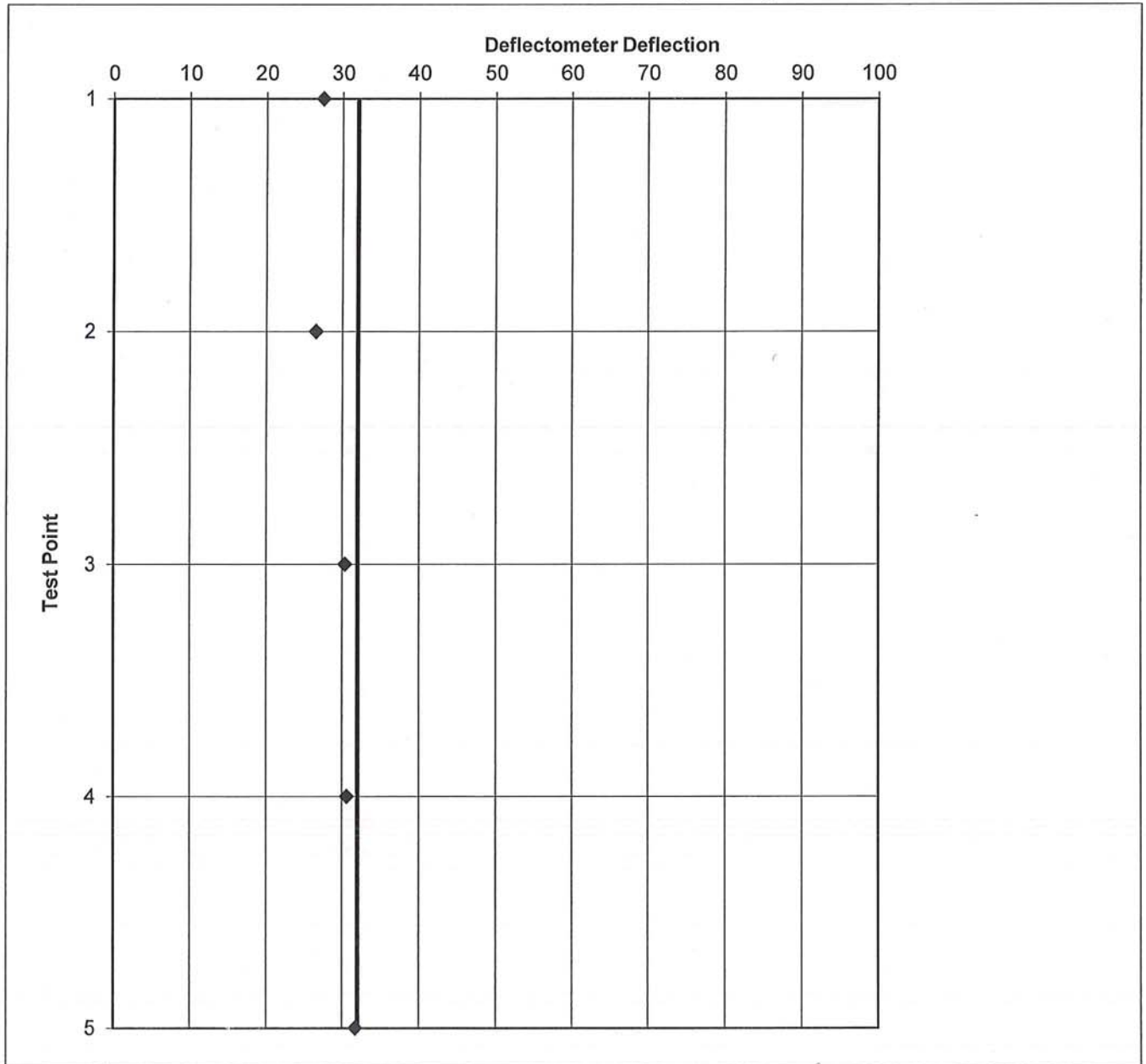

PAVEMENT ENGINEERING INCORPORATED

Redding

Petaluma

San Luis Obispo

(530) 224-4535

(707) 769-5330

(805) 781-2265

09/12/13

Page 1

Butano Geotechnical

Road: North Entrance Road Survey Date: 08/26/13
From: Proposed Housing Area Thickness: 0.42
To: Parking Area Traffic Index: 5.50
Lane/Line: Project Number: 130091-02

Deflection Data Analysis

Deflection Readings (Equivalent Deflectometer Units)

No. of Tests	Low	Mean	High	Std. Dev.
5	21.28	31.26	38.52	8.53

Road Surface

Thickness	Traffic Index
0.42	5.50

Structural Design

Tolerable	80th Percentile	90th Percentile	% Reduction	GE Deficient
31.00	38.43	42.18	19.33	0.10

HMA Overlay
0.05



PAVEMENT ENGINEERING INCORPORATED

Redding

Petaluma

San Luis Obispo

(530) 224-4535

(707) 769-5330

(805) 781-2265

09/12/13

Page 2

Butano Geotechnical

Road: North Entrance Road
From: Proposed Housing Area
To: Parking Area
Lane/Line:

Survey Date: 08/26/13
Thickness: 0.42
Traffic Index: 5.50
Project Number: 130091-02

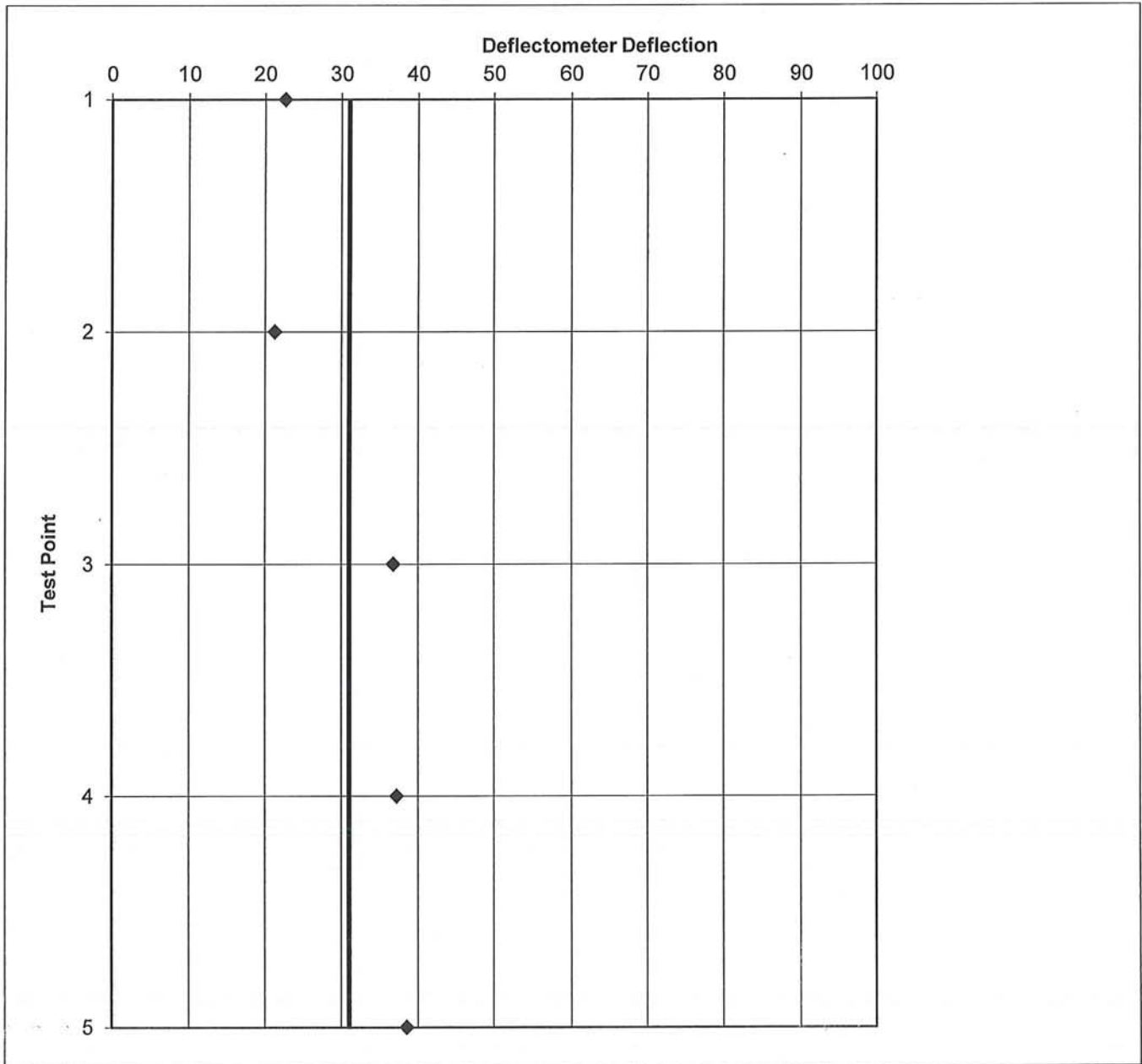

PAVEMENT ENGINEERING INCORPORATED

Redding

Petaluma

San Luis Obispo

(530) 224-4535

(707) 769-5330

(805) 781-2265

09/12/13

Page 1

Butano Geotechnical

Road: North Entrance Road Survey Date: 08/26/13
From: Perimeter Drive Thickness: 0.42
To: Parking Area Traffic Index: 5.50
Lane/Line: Project Number: 130091-02

Deflection Data Analysis

Deflection Readings (Equivalent Deflectometer Units)

No. of Tests	Low	Mean	High	Std. Dev.
5	14.93	26.75	37.39	8.31

Road Surface

Thickness	Traffic Index
0.42	5.50

Structural Design

Tolerable	80th Percentile	90th Percentile	% Reduction	GE Deficient
31.00	33.73	37.38	8.08	0.02

HMA Overlay
0.01



PAVEMENT ENGINEERING INCORPORATED

Redding

Petaluma

San Luis Obispo

(530) 224-4535

(707) 769-5330

(805) 781-2265

09/12/13

Page 2

Butano Geotechnical

Road: North Entrance Road

Survey Date: 08/26/13

From: Perimeter Drive

Thickness: 0.42

To: Parking Area

Traffic Index: 5.50

Lane/Line:

Project Number: 130091-02

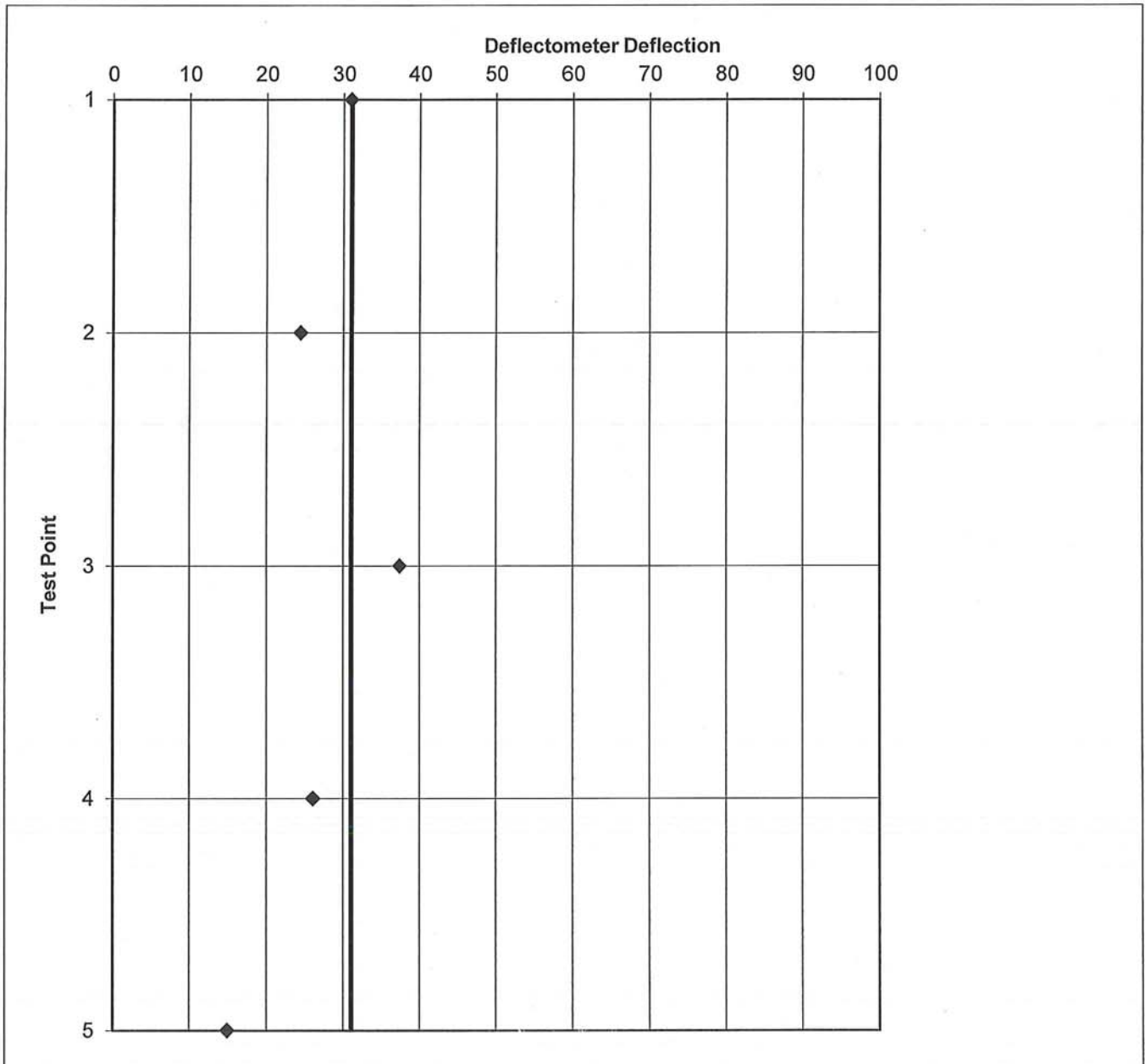
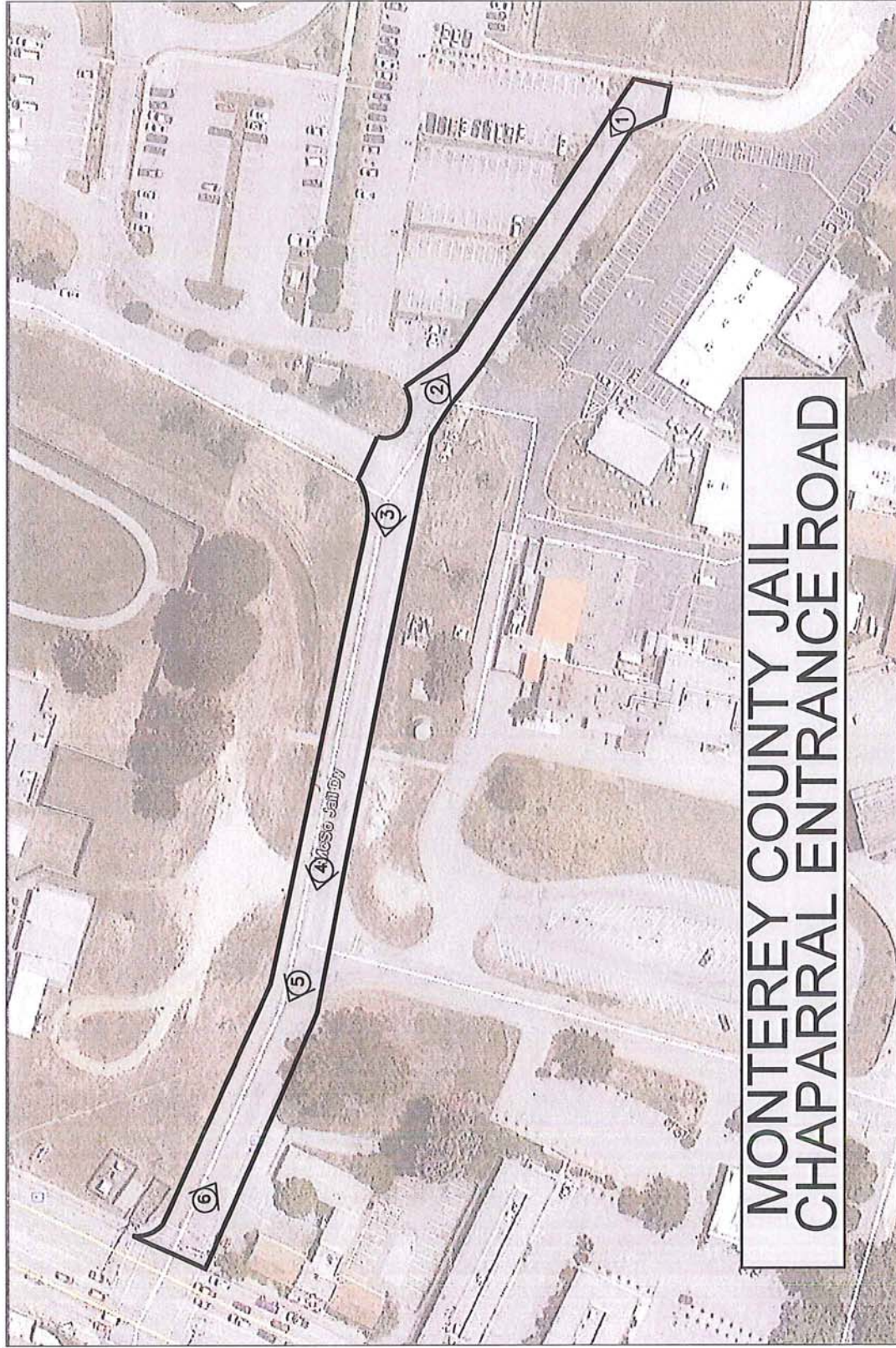

PHOTO LOG



MONTEREY COUNTY JAIL
CHAPARRAL ENTRANCE ROAD





**MONTEREY COUNTY JAIL FACILITY
PHOTO NO. 3 - PERIMETER DRIVE TO PARKING AREA**



**MONTEREY COUNTY JAIL FACILITY
PHOTO NO. 4 - PERIMETER DRIVE TO PARKING AREA**



**MONTEREY COUNTY JAIL FACILITY
PHOTO NO. 5 - NATIVIDAD ROAD TO PERIMETER DRIVE**



**MONTEREY COUNTY JAIL FACILITY
PHOTO NO. 6 - NATIVIDAD ROAD TO PERIMETER DRIVE**

APPENDIX E

CORROSION ANNALYSIS

October 10, 2013 (Revised)

Butano Geotechnical Engineering, Inc.
231 Green Valley Road, Suite E
Freedom, CA 95019

Attention: **Mr. Philip Edwards**
Staff Engineer

Subject: **Soil Corrosivity Evaluation & Recommendations for Corrosion Control
Concrete Foundations and Underground Domestic Water and Fire
Water Piping Systems
Monterey County Adult Jail Housing Addition
Salinas, CA**

Dear Mr. Edwards,

Pursuant to your request, **JDH Corrosion Consultants, Inc.** has conducted a site corrosivity evaluation for the above referenced project site and we have provided herein recommendations for long-term corrosion control for the concrete foundations and the underground utilities at this site.

Purpose

The purpose for this evaluation is to determine the corrosion potential, resulting from the soils at the subject site and to provide recommendations for long-term corrosion control for concrete foundations and the buried metallic utilities.

Background

The project involves the construction of two 1-story housing units and one 2-story housing unit as an expansion to existing facilities at the Monterey County Adult Jail in Salinas, California. The structures are assumed to have slab-on grade type foundations and there will be buried utilities associated with this development

Soil Testing and Analysis

Soil Testing Results

Ten (10) soil samples were collected from the site by **Butano Geotechnical Engineering, Inc.** field personnel and were transported to a state certified testing laboratory, **CERCO Analytical, Inc.** (DOHS certificate no. 2153) located in Concord, CA for chemical analysis. The samples were analyzed for pH, chlorides, resistivity (@ 100% saturation), sulfates and Redox potential using ASTM test methods as detailed in the table below. The preparation of the soil samples for chemical analysis was in accordance with the applicable specifications.

Soil Analysis Test Methods

Chemical Analysis	ASTM Method
Chlorides	D4327
pH	D4972
Resistivity (100% Saturation)	G57
Sulfate	D4327
Redox Potential	D1498

The results of the chemical analysis are provided in the CERCO Analytical, Inc. report dated May 10, 2013. The results are summarized as follows:

**CERCO Analytical, Inc.
 Soil Laboratory Analysis**

Chemical Analysis	Range of Results	Corrosion Classification*
Chlorides	Non Detected – 680 (mg/kg)	Corrosive to Non-corrosive *
pH	7.9 – 8.6	Non-corrosive*
Resistivity	450 – 2,400 ohms-cm	Severely corrosive to Moderately corrosive *
Sulfate	15 – 78 (mg/kg)	Non-corrosive**
Redox Potential	330 - 460 mV	Non-corrosive*

* With respect to bare steel or ductile iron.

** With respect to mortar coated steel

Chemical Testing Analysis

The chemical analysis provided by **CERCO Analytical, Inc.** indicates that based on this soil data, the soils are generally classified as “severely to moderately corrosive” based on the resistivity measurements. The chloride levels indicate “corrosive to non-corrosive” conditions to steel and ductile iron, and the sulfate levels indicate “non-corrosive” conditions for concrete structures placed into these soils with regard to sulfate attack. The pH of the soils is alkaline which classifies them as “non-corrosive” to buried steel and concrete structures

In-Situ Soil Resistivity Measurements

The in-situ resistivity of the soil was measured at five (5) locations at the project site by **JDH Corrosion Consultants, Inc.** field personnel. Resistance measurements were conducted with probe spacing of 2.5, 5, 7.5, 10 and 15-feet at each location. For analysis purposes we have calculated the resistivity of soil layers 0-2.5, 2.5-5, 5-10 and 10-15' using the Barnes Method as follows:

$$\rho_{b-a} = KR (b-a)$$

Where;

- ρ_{b-a} = soil resistivity of layer depth b-a (ohm-cm)
- a = soil depth to top layer (ft)
- b = soil depth to bottom layer (ft)
- R_a = soil resistance read at depth a (ohms)
- R_b = soil resistance read at depth b (ohms)
- R_{b-a} = resistance of soil layer from a to b (ft)
- K = layer constant = $60.96\pi(b-a)$ (cm)

and $\frac{1}{R_{b-a}} = \frac{1}{R_a} - \frac{1}{R_b}$

The visual diagrams below describe the Wenner 4-pin testing configuration.

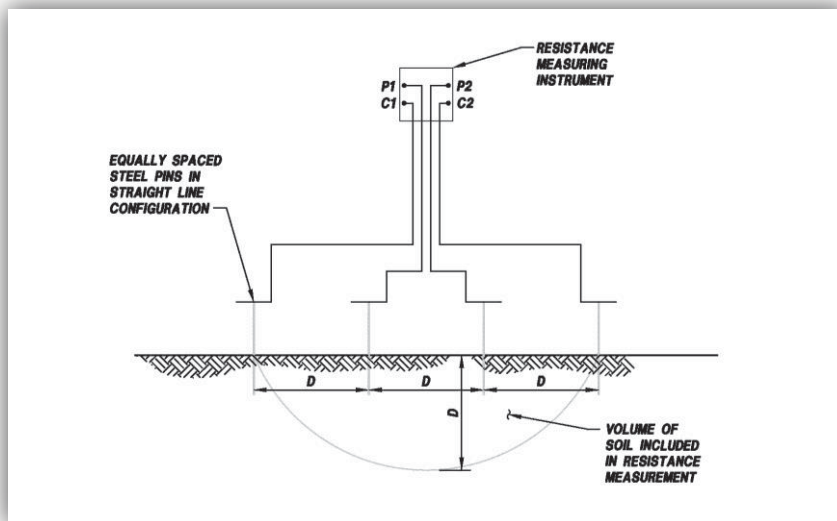

Fig 1: Wenner 4-Pin Resistivity Schematic No.1

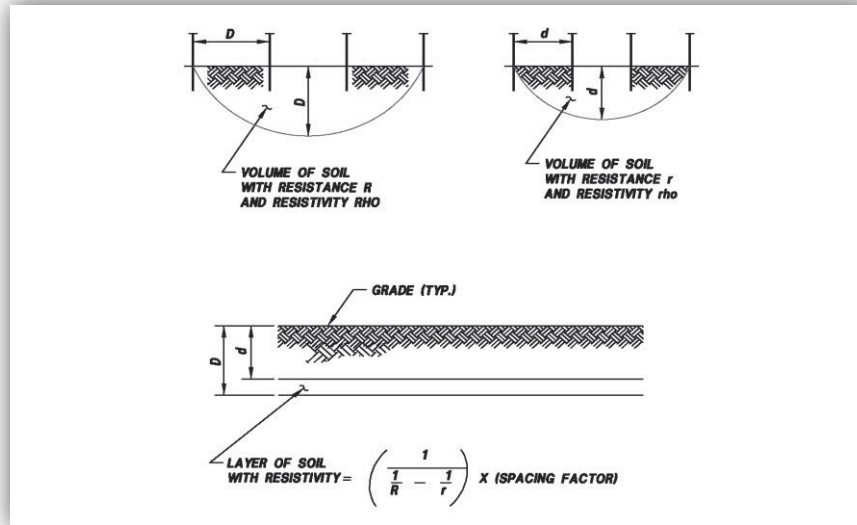

Fig 2: Illustration of Barnes Layer Calculations

In-Situ Soil Resistivity Analysis

Corrosion of a metal is an electro-chemical process and is accompanied by the flow of electric current. Resistivity is a measure of the ability of a soil to conduct an electric current and is, therefore, an important parameter in consideration of corrosion data. Soil resistivity is primarily dependent upon the chemical content and moisture content of the soil mass.

The greater the amount of chemical constituents present in the soil, the lower the resistivity will be. As moisture content increases, resistivity decreases until maximum solubility of dissolved chemicals is attained. Beyond this point, an increase in moisture content results in dilution of the chemical concentration and resistivity increases. The corrosion rate of steel in soil normally increases as resistivity decreases. Therefore, in any particular group of soils, maximum corrosion will generally occur in the lowest resistivity areas. The following classification of soil corrosivity, developed by William J. Ellis¹, is used for the analysis of the soil data for the project site.

<u>Resistivity (Ohm-cm)</u>	<u>Corrosivity Classification</u>
0 – 500	Very Corrosive
501 – 2,000	Corrosive
2,001 – 8,000	Moderately Corrosive
8,001 – 32,000	Mildly Corrosive
> 32,000	Progressively Less Corrosive

The above classifications are appropriate for the project site and the results are presented in the graphs below. In general, the soils are classified as “severely corrosive to progressively less corrosive” with respect to corrosion of buried steel structures throughout the top 2.5 to 15 feet of the site.

The chart of the in-situ soil resistivity data for the soil layers 2.5 to 15 feet indicate that 17% of the soils are classified as “severely corrosive”, 52% of the soils are classified as “corrosive”, 17% of the soils are classified as “moderately corrosive”, 9% of the soils are classified as mildly corrosive and 4% of the soils are classified as “progressively less corrosive”.

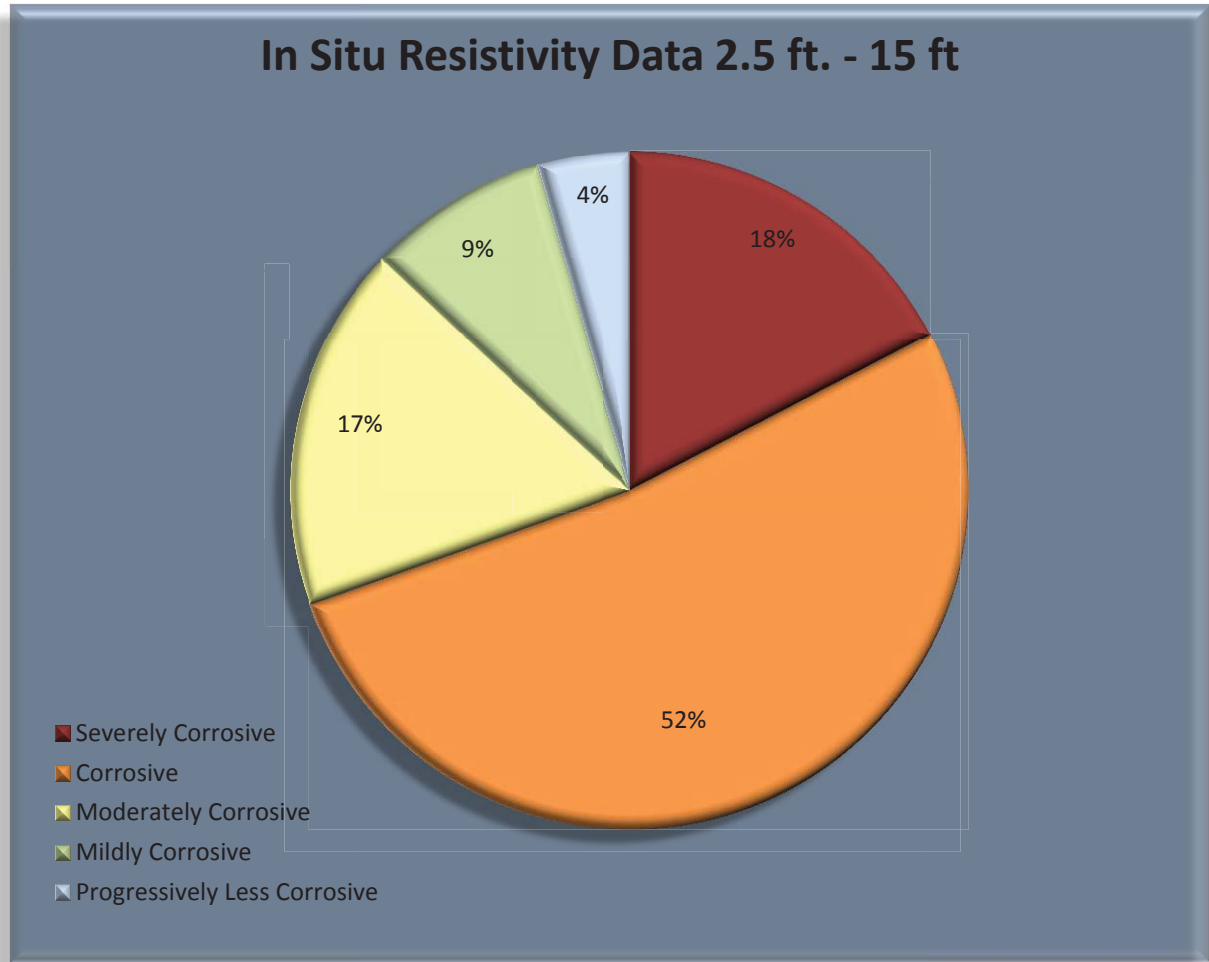

Discussion

Reinforced Concrete Slab Foundations

Due to the high levels of water-soluble chlorides found in the soils, a concrete mix design appropriate for high levels of chloride exposure is recommended. The type of cement used should be in accordance with California Building Code (CBC). The minimum depth of cover for the reinforcing steel should be as specified in CBC as well.

Underground Metallic Pipelines

The soils at the project site are considered to be “severely corrosive to progressively less corrosive” to ductile/cast iron, steel and dielectric coated steel. Therefore, we recommend the use of coatings, and/or polyethylene encasement, supplemented with cathodic protection for direct buried metallic pressure piping such as domestic and fire water pipelines. All underground pipelines should also be electrically isolated from above grade structures, reinforced concrete structures and copper lines in order to minimize potential galvanic corrosion problems.

Recommendations

Reinforced Concrete Slab Foundations

For application in all concrete in contact with the soil, we recommend using a Type II modified cement mix with a maximum water-to-cement ratio of 0.40 and a minimum depth of cover for the reinforcing steel of 3-inches. Also, a mineral admixture shall be added to the concrete mix. The amount of mineral admixture shall be 25% of the total amount of the cementitious material used in the concrete mix and shall be comprised of 80% by mass mineral admixture conforming to ASTM Designation: C618 type F or N and 20% by mass mineral admixture meeting ASTM Designation: C 1240.

Ductile Iron Pipe (Pressure Piping such as Domestic Water and Fire)

1. Direct buried ductile iron pipe should be encased in 8-mil polyethylene as specified in AWWA specification C-105. Epoxy coatings are also an acceptable alternative type of coating system for the pipe and/or fittings such as valves.
2. All rubber gasket joints, fusion-bonded epoxy coated flanges and flexible couplings on ductile iron pipelines should be bonded with insulated copper cable to insure electrical continuity of the pipeline and fittings.
3. Insulating flanges and/or couplings should be installed to electrically isolate the buried portion of pipeline from other metallic pipelines, reinforced concrete structures and above grade buildings or structures.
4. Test stations shall be installed on all ductile iron pipelines at a spacing of 800 to 1,000 feet. Bonding and test stations shall comply with NACE Standards.
5. A sacrificial type of cathodic protection utilizing ***H-1 magnesium*** anodes should be installed to protect the entire length of buried metallic pipeline. Cathodic protection should be designed in accordance with NACE Standard SP0169-07 and applicable local standards and included with the contract documents to permit installation along with the pipeline.

6. As an alternate, non-metallic piping may be used in lieu of ductile iron piping as allowed by State and local codes. Non-metallic piping does not require the implementation of any special type of corrosion prevention measures. However, all metallic valves, fittings and appurtenances on non-metallic piping will require protection as specified below.

Ductile Iron Fittings & Metallic Valves (On Plastic Pressure Piping)

1. All direct buried ductile iron fittings installed on non-metallic piping shall be provided with a bituminous coating from the factory and encased in an 8-mil polyethylene bag in the field in accordance with AWWA Specification C-105. All bolts, restraining rods, etc. shall be coated with bitumastic prior to encasement in the polyethylene bag.
2. All metallic valves shall be coated from the factory (i.e. using powdered epoxy or equivalent type of coating system) and all bolts shall be coated with bitumastic in the field and the entire valve shall be encased in an 8-mil polyethylene bag in accordance with AWWA Specification C-105.
3. A sacrificial type of cathodic protection utilizing **H-1 magnesium** anodes should be installed to protect the valves and fittings. Cathodic protection should be designed in accordance with NACE Standard SP0169-07 and applicable local standards and included with the contract documents to permit installation along with the pipeline.

Cast Iron (Gravity Sewer and Storm Drain Lines)

1. Direct buried ductile cast iron pipe should be encased in 8-mil polyethylene as specified in AWWA specification C-105.
2. As an alternate, non-metallic piping may be used in lieu of cast iron piping as allowed by State and local codes. Non-metallic piping does not require the implementation of any special type of corrosion prevention measures.

Steel Pipelines (Natural Gas Pipelines & Risers)

1. A fusion-bonded epoxy coating system or a suitable tape coating should be applied to all buried steel pipelines in accordance with ANSI/AWWA C214-95, "AWWA Standard for Tape Coating Systems for the Exterior of Steel Water Pipelines." Also, a tape coating per AWWA Standard C209-95 is recommended for special sections, connections and fittings.
2. Insulating flanges and/or couplings should be installed to electrically isolate the buried portions of steel pipelines from other metallic pipelines, reinforced concrete structures and above grade structures.
3. All rubber gasket joints, fusion epoxy coated flanges and flexible couplings should be bonded with insulated copper cable to insure electrical continuity of the pipeline and fittings.
4. A sacrificial type of cathodic protection using **H-1 magnesium** anodes should be installed to protect the buried portions of steel pipelines used for the natural gas piping systems. Cathodic protection should be designed in accordance with NACE Standard

**Site Corrosivity Evaluation
Monterey County Adult Jail Housing Addition, Salinas, CA**

SP0169-07 and applicable local standards and included with the contract documents to permit installation along with the subject pipeline.

5. As an alternate, non-metallic piping may be used in lieu of steel piping as allowed by State and local codes. Non-metallic piping does not require the implementation of any special type of corrosion prevention measures.

Copper Water Pipelines (Service Lines)

1. All copper water laterals shall be provided with a polyethylene sleeve to effectively isolate the copper piping from the earth.
2. All copper water laterals shall be electrically isolated from metallic water mains via the use of insulating type corporation stops installed at the water main.
3. A sacrificial type of cathodic protection utilizing **H-1 magnesium** anodes should be installed to protect the valves and fittings. Cathodic protection should be designed in accordance with NACE Standard SP0169-07 and applicable local standards and included with the contract documents to permit installation along with the pipeline.

LIMITATIONS

The conclusions and recommendations contained in this report reflect the opinion of the author of this report and are based on the information and assumptions referenced herein. All services provided herein were performed by persons who are experienced and skilled in providing these types of services and in accordance with the standards of workmanship in this profession. No other warranties or guarantees either expressed or implied are provided.

We thank you for the opportunity to be of assistance on this important project. If you have any questions concerning this report or the recommendations provided herein, please feel free to contact us at (925) 927-6630.

Respectfully submitted,

Mohammed Ali

Mohammed Ali., P.E.
JDH CORROSION CONSULTANTS, INC.
Principal



Brendon Hurley

Brendon Hurley
JDH CORROSION CONSULTANTS, INC.
Field Technician

**Site Corrosivity Evaluation
Monterey County Adult Jail Housing Addition, Salinas, CA**

CC: File 13073

REFERENCES

1. *Ellis, William J., Corrosion of Concrete Pipelines, Western States Corrosion Seminar, 1978*
2. *AWWA Manual of Water Supply Practices - M27, First Edition, External Corrosion - Introduction to Chemistry and Control (Denver, CO: 1987)*
3. *National association of Corrosion Engineers, Standard Recommended Practice, SP 01-69-07, Control of External Corrosion on underground or Submerged Pipeline*

Client: Butano Geotechnical
Project: Monterey County Adult Jail Housing Addition
Location: Salinas, CA
Date: 5/16/2013
Subject: In-Situ Soil Resistivity Data



*Test #	Location Description	Resistance Data From AEMC Meter						Soil Resistivities (ohm-cm)						Barnes Layer Analysis (ohm-cm)				
		2.5	5	7.5	10	15	2.5	5	7.5	10	15	0-2.5'	2.5-5'	5-7.5'	7.5-10"	10-15'		
1	Locked Area Boring B6	10.50	1.69	0.75	0.44	0.76	5027	1618	1077	843	2183	5027	964	646	510	NA		
2	Near Boring B10	16.80	2.36	0.50	1.46	0.41	8043	2260	718	2796	1178	8043	1315	304	NA	546		
3	Near Boring B7	7.95	2.40	0.97	0.44	0.35	3806	2298	1393	843	1005	3806	1646	779	386	1638		
4	Near Boring B4	71.40	9.81	1.05	0.48	0.37	34183	9393	1508	919	1063	34183	5445	563	423	1546		
5	Between B4 and B8	20.60	1.46	0.41	0.38	0.52	9862	1398	589	728	1494	9862	752	273	2486	NA		



BUTANO GEOTECHNICAL ENGINEERING, INC.
231 GREEN VALLEY ROAD, SUITE E, FREEDOM, CALIFORNIA 95019
PHONE: 831.724.2612
WWW.BUTANOGEOTECH.COM

January 16, 2015
Project No. 12-126.1-M

Kimley-Horn and Associates
11919 Foundation Place #200
Rancho Cordova, California 95670

SUBJECT: PERCOLATION TESTING
Monterey County Jail Housing Addition
Natividad Road
Salinas, California

ATTENTION: Chris Jones

Dear Mr. Jones:

Per your request our firm conducted percolation testing at the subject site. Percolation testing procedures, results, and the location of the test holes are included herein.

It is a pleasure being associated with you on this project. If you have any questions or if we may be of further assistance please do not hesitate to contact our office.

Sincerely,

BUTANO GEOTECHNICAL ENGINEERING, INC.

Greg Bloom, PE, GE
Principal Engineer
R.C.E. 58819
Expires 6/30/13

Attachments:

Percolation Testing ProceduresPg. 2
Percolation Testing Results.....Pg. 3
Percolation Testing Site Plan.....Figure. 1

PERCOLATION TESTING PROCEDURES

Falling head percolation tests were performed at four locations on the parcel. Eight holes were tested at depths of 5 and 7 feet from existing grade. The holes were filled with water to a height approximately 12 inches from the base of the hole. A rate reduction factor was used to convert percolation rates to infiltration rates. The approximate locations of the test holes are shown on the Percolation Site Plan (Figure 1).

The holes were logged in the field during the drilling process. Borings P-1 and P-4 were drilled into fill composed of light brown to orange silty SAND processed from the on-site sand stone bedrock. Borings P-2 and P-3 were drilled a minimum of 6 inches below the fill into the underlying sandstone bedrock.

The percolation test holes were drilled with a 3-inch diameter solid stem auger using portable equipment. Perforated pipe was inserted to prevent potential collapse of the test holes and approximately 2 to 3 inches of clean, crushed 3/8" gravel was placed at the bottom of the holes as well as around the annulus of the pipe. The test holes were pre-soaked prior to percolation testing.

The percolation rates were recorded every 30 minutes until 3 consecutive measurements were within 10% of each other. The following rates report the average of those 3 consecutive measurements.

PERCOLATION TESTING RESULTS:

Percolation Test Hole (3 inch diameter)	Depth (ft)	Soil Description	Percolation Rate (inches/hour)	Infiltration Rate (inches/hour)
P1	7	Tan fat CLAY with sand	2.08	0.30
P2	7	Dark brown fat CLAY	0.00	0.00
P3	5	Dark brown fat CLAY	0.00	0.00
P4	5	Tan fat CLAY with sand	0.00	0.00
P5	7	Brown lean CLAY with sand	0.58	0.06
P6	5	Brown lean CLAY with sand	1.50	0.15
P7	5	Tan fat CLAY with sand	0.00	0.00
P8	7	Tan fat CLAY with sand	0.00	0.00

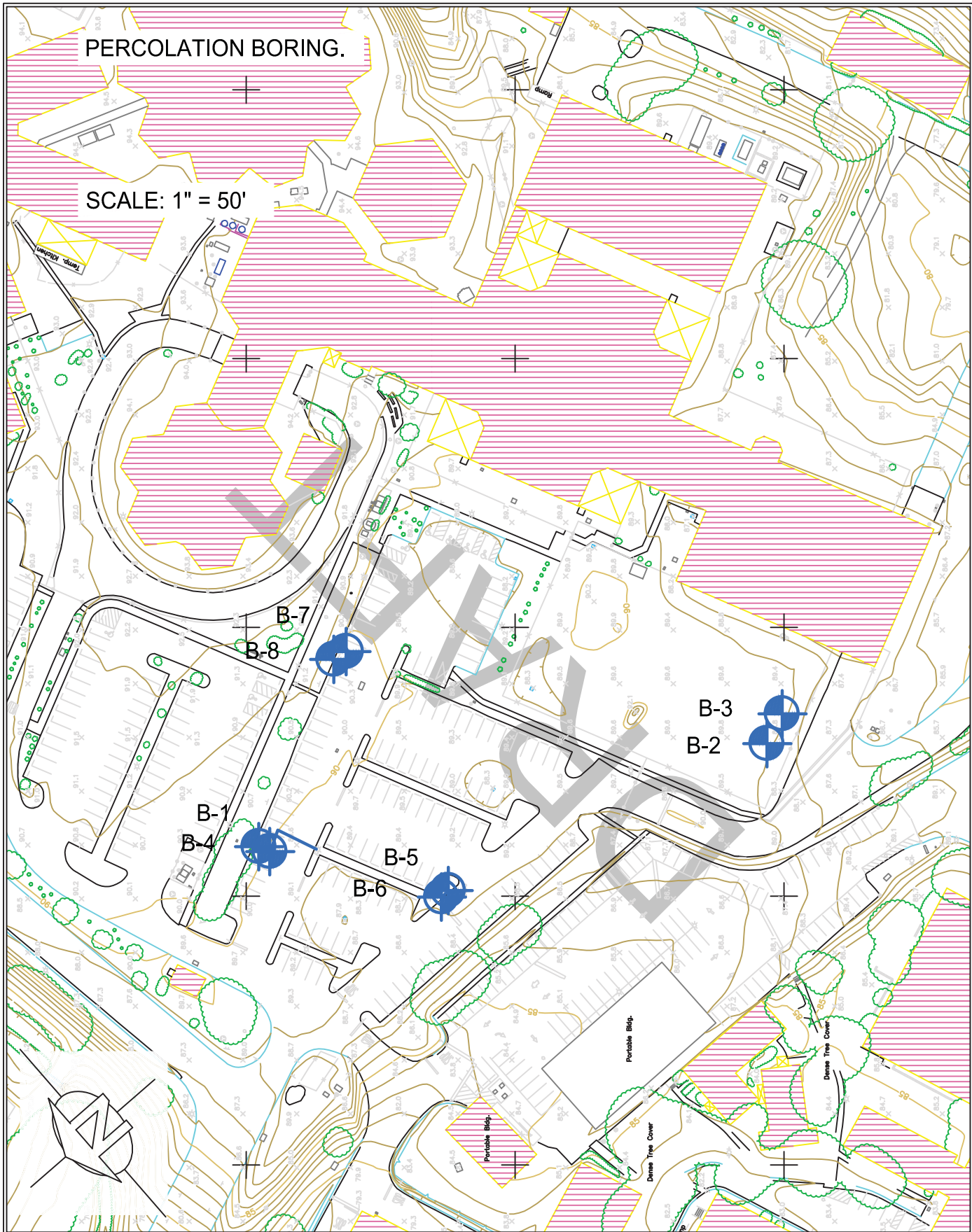

BUTANO
 GEOTECHNICAL ENGINEERING, INC.

PERCOLATION SITE PLAN
 Monterey County Adult Jail Housing Addition

FIGURE
 1