

Attachment F

This page intentionally left blank.

Keith Higgins

Traffic Engineer

August 14, 2020

Lawrence W. Horwitz, Esq.
Horwitz & Armstrong
14 Orchard, Suite 200
Lake Forest, CA 92630

Re: Abundant Investments Cannabis Retailer Response to Planning Commission and Additional Comments, North Monterey County, California

Dear Mr. Horwitz,

Per your request, this is a response to Monterey County Planning Commission findings dated May 13, 2020 as well as additional staff comments from the Monterey County Public Works Department received in an email dated July 24, 2020 for the proposed Abundant Investments Cannabis Retailer (Abundant Investments), 1031 North El Camino Real, North Monterey County, California. The Project is a 1,413 square-foot Cannabis Retailer proposed to occupy an existing building. The building has occupied the site for many years. A Tuff Shed sales facility occupied the building from about 2015 through late 2019. The used car sales lot occupied the site from about 2005 through 2010. **Exhibit 1** depicts the project site location. **Appendix A** contains a copy of the reference county email.

The following are the specific traffic operations and safety assertions in the Planning Commission findings, as well as the additional staff comments, with my corresponding responses. The assertions/comments and responses are organized by topic.

A. PROJECT SITE TRIP GENERATION

1. Planning Commission Assertion – “There is no evidence that the proposed cannabis retailer will not change project site trip generation. The proposed use would potentially increase and intensify vehicular traffic to and from the site.”

2. Response - The “Trip Generation Manual”, 10th Edition, Institute of Transportation Engineers (ITE), 2017 (ITE Manual), is normally considered the source for trip generation data for land development projects. The ITE Manual includes trip rates for cannabis retail uses under “Land Use Category 882 – Marijuana Dispensary.” The weekday average trip generation rate per 1,000 square feet of floor area for a marijuana dispensary is 252.70 trips per day with 10.44 in the AM peak hour, 33.53 in the PM peak hour. Saturday trip generation rates include 258.15 per day with 11.39 during the project peak hour. However, these average rates are grossly inflated for the following reasons.

a. The ITE Manual Includes the First Cannabis Dispensaries in the United States

Exhibit 2 provides a tabular breakdown of the ITE trip generation data for marijuana dispensaries. There is a 10-fold range in rates at the sites compiled by ITE, which is an extremely wide range. Two projects (Projects 1 and 2) are anomalies in the data set that substantially increase the average rates. This is clear in all data sets for peak hours and weekends in which these two projects are included. These high rates are likely because the data was collected in the early days of legalized Marijuana use in Colorado. The cannabis market had not matured and counts at the first dispensaries captured the initial novelty and lack of competition. Using the overall ITE weighted average therefore over- estimates the trips that will be generated by Abundant Investments.

b. Local Trip Generation Data Supports a Lower Rate

To establish a rate that is more appropriate for the Salinas market, an all-day manual count was conducted at the existing Emerald Skyway marijuana dispensary at 1610A Merritt Street, Salinas, California, on Thursday, May 31, 2018. This data was collected for East of Eden, which has been in operation in Salinas since 2019. According to the Emerald Skyway website, it is a recreational and medical cannabis collective serving Monterey County and the greater Monterey Bay area. It has a total of about 4,200 square feet of floor area. The Emerald Skyway raw traffic count data is tabulated in **Appendix B**. Emerald Skyway generated a total of 284 daily trips with 5 during the AM peak hour and 41 during the PM peak hour. This is a rate of 67.6 trips per day with 1.19 during the AM peak hour and 9.76 during the PM peak hour. This is slightly less than the ITE rates when excluding Projects 1 and 2. Incidentally, since the counts were conducted at Emerald Skyway, one other cannabis sales facility has opened in Salinas. Cannabis facilities are also now in operation in Castroville and Moss Landing. Other cannabis dispensaries and retail facilities have also been proposed in the Salinas, Prunedale and Castroville areas, as well as elsewhere in Marina and the southern Salinas Valley cities. The proliferation of these facilities will likely reduce trip generation rates for all cannabis facilities.

c. Additional Trip Generation Data Supports a Lower Rate

Additional trip generation data was obtained from an on-line literature search. The “Ascend Mass, LLC Proposed Registered Marijuana Dispensary Traffic Impact Statement, Hayes Engineering, Inc., October 31, 2018, which is included as **Appendix C**, states the following.

“The ITE numbers resulted in excessive and unbelievable trip estimates and were checked against real data from point of sales for customer counts from an existing and operating 1,600-sf. RMD (Recreational Marijuana Dispensary) in the Harvard Square section of Cambridge. The facility was surveyed during the month of February 2018 and averaged 21 customers per day, an average rate of 13.13 customers per 1,000-sf.”

The 1,600 square-foot Harvard Square facility generates about 42 daily customer trips plus 10 employee trips and 2 delivery trips per day, for a total of 54 daily trips. This is a rate of about 33.75 trips per day per 1,000 square feet. This would result in an estimate of 48 daily trips for Abundant Investments. Assuming about 14% occur in the PM peak hour, a total of about 7 trips, or 3

customers, would occur in the PM peak hour. This is similar to the counts at 5 of the 12 sites in the ITE database. Nine of the 12 sites counted in the ITE data have lower PM peak hour trip counts than Emerald Skyway. The inclusion of the Harvard Square would result in average trip rates very similar to the Emerald Skyway count.

d. Current Industry Trends Toward Delivery Services Support a Lower Rate

Based on the additional data from Emerald Skyways and Harvard Square, the modified ITE data is reasonable for estimating trips for the proposed project. This would result in an estimate of about 5 AM (3 inbound and 2 outbound) and 18 PM (9 inbound and 9 outbound) trips. About 139 daily trips would occur based on the Emerald Skyways trip count. This assumes 13% of daily trips occur in the PM peak hour (actual data is about 14% of daily trips occur in the PM peak hour, which would result in an estimate of 129 daily trips).

However, even the trip generation estimates above are likely to be high given new trends toward a home-delivery based operation. Some of this is due to the recent COVID-19 shelter-in-place policies, which are expected to result in long-term transition to shopping on-line and via delivery, which is occurring even for groceries. This would especially be true for a product with a long shelf life like cannabis. This is because there is a social stigma to shopping at a cannabis facility and many customers have health needs or are caregivers who prefer home delivery.

According to the market study included in **Appendix D**, between 40% and 45% of project sales will be from deliveries. The delivery service can make multiple stops on a single delivery route due not only to the long shelf life of the product but also the ability to purchase a long-term supply. Deliveries are also generally done during off-peak hours because traffic reduces delivery profit margins because of the time the driver spends idling. Further, a delivery service also has the incentive to compile as many orders as possible into as few trips as possible. The delivery service therefore could reduce trips even further. Applying a 40% reduction in trips results in an estimate of about 84 daily trips, 3 AM trips (2 inbound and 1 outbound) and 10 PM trips (5 inbound and 5 outbound). A summary of project trip generation is provided on **Table 1** below.

	Daily Trips	AM Peak Hour			PM Peak Hour		
		In	Out	Total	In	Out	Total
With Minimal Delivery	140	3	2	5	8	8	16
With 40% Delivery	84	2	1	3	5	5	10

Table 1 – Project Trip Generation

e. The Cannabis Retailer Will Generate Traffic Virtually Identical to Allowable Alternative Uses

This section compares the cannabis retail trip generation with other possible uses that are allowed in the Project's zoning category. The Project site is zoned Light Commercial in the Monterey County Zoning Ordinance, which allows the uses listed on the top of the following page with an administrative permit. The closest corresponding ITE land use category and number are indicated in parentheses. The ITE Land use designations are used for estimating project site traffic generation.

- A. Appliance store (Furniture Store - 890)
- B. Barber shop (Variety Store – 814; Hair Salon – 918)
- C. Beauty shop (Variety Store – 814; Hair Salon - 918)
- D. Book store (Variety Store - 814)
- E. Clothing and apparel store (Apparel Store - 876)
- F. Drug store (Pharmacy/Drug Store - 880)
- G. Banks less than 5,000 square feet (Walk-in Bank - 911)
- H. Shoe shop (Apparel Store - 876)
- I. Shoe store (Apparel Store - 876)
- J. Art gallery (Arts & Crafts Store - 879)
- K. Convenience market (Convenience - 851)
- L. Stationery and office supply store (Variety Store - 814)
- M. Photography studio (Variety Store – 814)
- N. Florist (Variety Store – 814)
- O. Gift and card store (Arts and Crafts – 879)
- P. Office (710 or 712)
- Q. Locksmith, key and lock shop (Variety Store – 814)
- R. Bicycle shop (Variety Store – 814)
- S. Hardware store, excluding lumber and outside storage of materials (Hardware/Paint – 816)
- T. Picture framing (Arts and Crafts – 879)
- U. Storage, rental and sale of irrigation equipment (Construction Equipment Rental – 811)
- V. Other uses of a similar character, density and intensity to those listed in this Section
- W. Pet shop (Variety Store – 814)
- X. Cannabis retailer pursuant to Chapter 21.67 (Proposed Project)

Under the Light Commercial Zoning designation, the following uses are allowed with a use permit. Uses that would either exceed the available floor area or are clearly not practical are designated with N.A. (Not Applicable). These include hotel/motel, bank larger than 5,000 square feet, mini-warehouse, or service station or a stand-alone parking lot or assemblies.

- A. Hotels and motels – N.A.
- B. Animal hospitals (Animal Hospital – 640)
- C. Parking lots – N.A.
- D. Auto sales ((Automobile Sales Used) – 841)
- E. Banks greater than 5,000 square feet – N.A.

Lawrence W. Horwitz, Esq.
August 14, 2020

- F. Open air retail and wholesale sales (Farmers Market – 858)
- G. Mini warehouse storage warehouses - N.A.
- H. Theaters – N.A.
- I. Restaurants (Fast Casual – 930)
- J. Service stations - N.A.
- K. Caretaker unit for on-site security - N.A.
- L. All residential uses with size limitations - N.A.
- M. Assemblages of people, such as carnivals, festivals, races and circuses not exceeding ten (10) days and not involving construction of permanent facilities – N.A.
- N. Public and quasi-public uses including churches, parks, playgrounds, schools, public safety facilities, public utility facilities (Church – 560 and Day Care Center - 565)

Exhibit 3 provides an estimate of trip generation for each of the above uses based the ITE Manual. This indicates that the number of trips generated by the project building with uses that require only an administrative permit could be as high as 1,077 trips per day for a convenience market. This and several other allowable uses would generate more traffic than the proposed project. More likely, the use would be something in the Variety Store (ITE Land Use Code 814) land use category. These would generate about 90 trips per day with 4 in the AM peak hour and 10 in the PM peak hour. This is virtually identical to the trip generation expected from the proposed Cannabis Retailer trip generation of 83 daily trips, 3 AM trips and 10 PM trips described in Section 1.d above.

The most recent use of the project site was a Tuff Shed retail facility. The prior use was a used car lot. There is no directly comparable trip generation rate for the Tuff Shed facility. It would most closely correspond to a Construction Equipment Rental (ITE Land Use Category 811) or Auto Sales – Used (ITE Land Use Category 841). The Construction Equipment Rental use would be expected to generate about 25 daily trips and 2 AM and 2 PM peak hour trips, which would be the equivalent of one customer or employee arriving and leaving during the peak hour. The previous “Auto Sales – Used” use would be expected to generate about 38 daily trips with 3 in the AM peak hour and 5 in the PM peak hour. The recent uses likely generated slightly less traffic than the proposed Cannabis facility as well as virtually any other allowable use. However, the differences of 2 to 5 peak hour trips is imperceptible.

B. ACCIDENT HISTORY

1. Planning Commission Assertion – “Testimony was received during review of the project indicating that the site is in an unsafe location due to vehicles traveling high speeds along Highway 101 directly conflicting with cars entering/exiting El Camino Real, which intersects with Highway 101. Monterey County Public Works compiled collision data from the California Statewide Integrated Traffic Records System (SWITRS) between January 2015 through December 2019. During this five-year period, ten (10) collisions were reported moving southbound on Hwy 101. These collisions occurred within the segment of Hwy 101 that is 600 feet north and 300 feet south of the site, where El Camino Real intersects with Hwy 101. The collisions were attributable to driver behavior (seven were for unsafe speed, two were under the influence of drug or alcohol and one was for improper turning).”

Lawrence W. Horwitz, Esq.
August 14, 2020

2. Response - Prunedale South Road intersects US 101 along the southbound acceleration lane from the State Route 156 interchange, which is a non-standard configuration. However, there is no evidence of a safety issue at this intersection based on the most recent 5-year collision history.

The May 13, 2020 Monterey County Planning Commission staff report for Agenda Item No. 2 reported a total of 10 collisions located on US 101 within 600 feet north and 300 feet south of Prunedale South Road, per the California Statewide Integrated Traffic Records System (SWTRS) between January 2015 and December 2019. Of these collisions, seven occurred due to unsafe vehicle speeds, two drivers were under the influence of drugs or alcohol and one was cited for improper turning.

To confirm this data, an analysis of SWTRS collision data was obtained through the Transportation Injury Mapping System (TIMS) platform provided by the University of California at Berkeley. **Exhibit 4** summarizes this data and **Exhibit 5** contains a collision diagram of these collisions. According to TIMS records, a total of nine collisions occurred near the Southbound US 101 / Prunedale South Road intersection between January 2015 and December 2019. Similar to the Monterey County collision data, seven of these collisions occurred due to unsafe vehicle speeds, one driver was under the influence of drugs or alcohol and one was cited for improper turning.

The most common collision type was Rear-End, which comprised six of the nine collisions. The other collision types were "Hit Object, Sideswipe and Broadside, all of which occurred once. The Hit Object collision involved a fatality, while the other eight collisions involved at least one injury. None of the nine collisions involved pedestrians, bicyclists or motorcycles.

Overall, the fact that the majority of collisions were rear-end collisions, combined with a high prevalence of unsafe speeds as the primary collision factor, are reflective of the collisions occurring on a high-speed roadway (like US 101) near an interchange (State Route 156). There are no indications that the collisions occurred directly due to safety issues at the intersection of Southbound US 101 and Prunedale South Road.

3. Staff Comment – Provide a collision diagram and analyze collision history on Prunedale South Road.

4. Response – SWTRS (Statewide Traffic Record System) collision data was obtained from Monterey County staff for Prunedale South Road between Prunedale North Road and Blackie Road (including the Prunedale South Road / Blackie Road intersection) from January 2013 through December 2018. **Exhibit 6** summarizes this data and **Exhibit 7** contains a collision diagram for this corridor. A total of 17 collisions occurred on Prunedale South Road over this 6-year period – 12 on Prunedale South Road between public street intersections and 5 at the Prunedale South Road / Blackie Road intersection itself. Only 4 of the 17 collisions occurred at night.

Twelve of the 17 collisions on Prunedale South Road itself. All of these collisions were the result of hitting fixed objects along the roadway frontage, one of which resulted in a vehicle overturning. Nearly all of these collisions were clustered in specific areas of Prunedale South Road –

Lawrence W. Horwitz, Esq.
August 14, 2020

- 1) A horizontal curve with trees 1,050 feet north of Blackie Road (3 collisions). A change in posted speed limit (25 mph south of the curve, 40 mph through the curve);
- 2) A horizontal curve with trees 2,100 feet north of Blackie Road (4 collisions); and
- 3) A cluster of trees 3,200 feet north of Blackie Road.

The remaining five collisions were all located at the Prunedale South Road / Blackie Road intersection and were related to conflicting traffic – three broadside collisions, one rear end collision and one vehicle-pedestrian collision. These are some of the typical collision types that are common at signalized intersections.

The collision rate at the Southbound US 101 / Prunedale South Road intersection is 0.17 collisions per million vehicles, which is about the same as the statewide average of 0.16 collisions per million vehicles for this type of intersection. The collision rate at the Prunedale South Road / Blackie Road intersection is 0.36 collisions per million vehicles, which is under the statewide average of signalized intersections of 0.43 collisions per million vehicle miles. See **Appendix E** for the collision rate calculations.

The segment collision rate on Prunedale South Road is 3.90 collisions per million vehicle miles, which is three times the statewide average of 1.08 collisions per million vehicle miles. Based on the types and locations of the collisions along Prunedale South Road, the horizontal curves at the end of extended straight segments of road contribute to the higher-than-average collision rate.

According to Monterey County Public Works traffic counts in 2019, Prunedale South Road carries approximately 1,200 vehicles per day. This is equivalent to LOS A operations. The project would add approximately 24 daily trips, increasing the daily volumes by approximately 2%. Traffic will continue to operate at LOS A with project traffic. The Project will result in an imperceptible effect on Prunedale South Road traffic operations. If the same collision rate on Prunedale South Road were to continue into the future, the additional project trips added to this roadway would add about one collision every 25 years. This is an imperceptible increase in collisions. Due to the currently high collision rate, the following improvements are recommended on Prunedale South Road.

- a. Add delineators along the edge of the roadway at all three collision cluster locations on Prunedale South Road. Monterey County would be responsible for implementing this improvement.
- b. Relocate the existing speed limit signs on Prunedale South Road so that the 25 mph speed limit extends north of the horizontal curve approximately 1,050 feet north of Blackie Road. Monterey County would be responsible for implementing this improvement.
- c. Consider adding additional advance warning and chevron signs at the horizontal curves on Prunedale South Road. Monterey County would be responsible for implementing this improvement.
- d. Consider adding an additional northbound through signal head on the near left corner to provide an earlier signal indication for Prunedale South Road traffic approaching Blackie Road from Reese Circle. Monterey County would be responsible for the implementation of this improvement.

Lawrence W. Horwitz, Esq.
August 14, 2020

- e. Trim the foliage surrounding the existing culvert on Prunedale South Road immediately east of Prunedale North Road. This foliage obscures the existing object markers on the culvert railings adjacent to the culvert edge, thereby hiding the presence of the culvert from drivers on Prunedale South Road. Monterey County would be responsible for the implementation of this improvement.
- f. Consider adding "Narrow Bridge" (W5-2) signs in advance of this culvert. Monterey County would be responsible for the implementation of this improvement.

C. TRAFFIC INCREASES ON NEARBY ROADS

1. **Planning Commission Assertion** – "The use will also create a diversion of traffic into the residential neighborhood adjacent to the site, causing an increase of traffic that will impact the neighborhood."

2. **Response - Exhibit 5** tabulates the existing traffic volumes on US 101, the Southbound US 101 On-ramp at the US 101/State Route 156 (SR 156) interchange and Prunedale South Road.

US 101 has an Average Daily Traffic (ADT) of 64,000, which is Level of Service (LOS) C. Per the Caltrans Guide for Preparation of Traffic Impact Studies publication, Caltrans endeavors to maintain a target LOS at the transition between LOS "C" and LOS "D" on State highway facilities, which is generally interpreted to be LOS C. US 101 south of SR 156 therefore currently operates acceptably with regard to traffic volumes and congestion.

The Southbound US 101 On-ramp at the US 101/State Route 156 (SR 156) interchange currently carries about 1,600 vehicles per day, which is well within the range of Level of Service A.

The project will represent an increase of about 20 daily trips (1.3% of the total volume) on the Southbound US 101 On-ramp at the project site. This is about one vehicle every 20 minutes, which would not change the level of service. By comparison, most retail uses would add essentially identical amounts of traffic to the Southbound US 101 peak hour volume. Some alternative uses that would be allowed by administrative permit would generate more traffic than the proposed project. In addition, a large component of project traffic will be from the passing stream of traffic on US 101 and State Route 156. A similar amount of traffic will be generated from the passing stream on Prunedale South Road. Because of the small size of the project, the proposed project as well as a majority of alternative uses will result in an imperceptible increase in traffic on nearby roads and highways.

3. **Planning Commission Assertion** – "The use will also create a diversion of traffic into the residential neighborhood adjacent to the site, causing an increase of traffic that will impact the neighborhood."

Lawrence W. Horwitz, Esq.
August 14, 2020

4. Response - Exhibit 8 shows intersection volumes at the Southbound US 101 / Prunedale South Road and Prunedale South Road – Prunedale North Road / Prunedale South Road intersections per AM and PM peak hour traffic counts conducted in August 2020. Also counted were peak hour traffic at the Prunedale South Road / Blackie Road intersection. These latter volumes were compared to volumes collected in April 2016, as cited from La Tourette Subdivision Traffic Impact Analysis, Keith Higgins Traffic Engineer, October 4, 2017 (“La Tourette traffic study”). The August 2020 and April 2016 volumes at Prunedale South Road / Blackie Road were used to derive growth rates to approximate pre-COVID-19 volumes at the other two study intersections. The adjusted volumes are shown on **Exhibit 9**. The adjusted volumes are used in the operational analysis.

Exhibit 10 summarizes the operations of the study intersections under Existing conditions, **Exhibit 11** summarizes the recommended improvements at each intersection and **Appendix F** contains the level of service calculations. All three of the study intersections operate at or better than their respective levels of service standards. No improvements are required for Existing conditions.

Exhibit 12 depicts the project trip assignment, which was derived from the project trip generation in **Table 1** and the project trip distribution depicted on **Exhibit 13**. This assignment was added to the Existing volumes to create Existing Plus Project volumes at the study intersections, which are shown on **Exhibit 14**.

Exhibit 10 summarizes the operations of the study intersections under Existing Plus Project conditions, while **Appendix F** contains the level of service calculations. The study intersections would continue to operate at or better than their respective levels of service. No improvements will be required for Existing Plus Project conditions.

The Prunedale South Road / Blackie Road intersection is not analyzed under Existing Plus Project conditions because the relatively small amount of traffic added by the study project would not cause this intersection to decline from its current acceptable LOS B.

Appendix G contains a left turn lane warrant evaluation for the southbound Prunedale North Road approach to the Prunedale South Road – Prunedale North Road / Prunedale South Road intersection. The left turn warrant is not met under either Existing or Existing Plus Project conditions.

D. NEARBY BUS STOP

1. Planning Commission Assertion – “There is a North Monterey County Unified School District bus stop directly in front of the proposed site. This proximity presents potential public safety risks for the students since there will be an increase in traffic which could result in pedestrian conflicts.”

2. Response - The project will generate very little traffic as described earlier in the letter. It will not affect traffic operations at the bus stop.

E. VEHICLE MILES TRAVELED

1. Staff Comment – Quantify Project Vehicle Miles Traveled (VMT)

2. Response - SB 743 changed the CEQA Guidelines statewide effective July 1, 2020. The changes to CEQA guidelines replace congestion-based metrics, such as auto delay and level of service, with Vehicle Miles Traveled (VMT) as the basis for determining significant impacts under the California Environmental Quality Act (CEQA), unless the guidelines provide specific exceptions. Monterey County has not established a VMT standard nor significance criteria for VMT evaluations in the county. As a result, this analysis uses state guidance with regards to analysis and significance criteria.

The publication *Technical Advisory on Evaluating Transportation Impacts in CEQA* (“TAETI-CEQA”), State of California Governor’s Office of Planning and Research, December 2018, discusses VMT evaluations for residential, commercial and office projects. As stated in this publication, projects generating 110 or fewer daily trips could be considered not to result in a significant impact on transportation. The project, as summarized on **Table 1**, will generate only 84 daily trips. Therefore, the project would not represent a significant transportation impact under CEQA.

F. SUMMARY AND RECOMMENDATIONS

The following is a summary of the above responses to the Monterey County Planning Commission traffic-related findings for the denial of the proposed Abundant Investment cannabis retailer plus additional comments raised by Monterey County Public Works Department staff. Several improvements to enhance safety and security in the immediate project vicinity are also recommended.

1. The proposed Abundant Investments cannabis retailer will generate traffic similar to trip generation from historic uses at the site as well as many other retail uses allowed in the project site’s Monterey County Zoning Ordinance Light Commercial land use category. Project traffic impacts will therefore also be essentially the same as other retail uses that have or could occupy the site.
2. The nearby roads and highways operate at an acceptable level of service. The project is proposed to occupy a very small existing building that will result in an imperceptible increase in traffic on the nearby road network.
3. The most recent 5-year collision history along US 101 immediately south of the Highway 156 overcrossing does not include any collisions associated with the southbound on-ramp or the US 101 / Prunedale South Road intersection. The collisions were associated with speeding, driving under the influence of drugs or alcohol and an improper turn. None were associated with the turns to and from Prunedale South Road. There is therefore no safety issue associated with this intersection.
4. The project will generate very little traffic as described earlier in the letter. It will not affect traffic operations at the nearby bus stop on Prunedale South Road.

Lawrence W. Horwitz, Esq.
August 14, 2020

5. The following are recommendations that will reduce project traffic to and from the US 101 / Prunedale South intersection, strengthen the prohibition of left turns onto US 101 or enhance visibility of the intersection.
 - a. The project should require all employees and deliveries to use Prunedale South Road to and from the west and avoid using the US 101 / Prunedale South intersection. This would eliminate at least 15% of project traffic (about 2 PM peak hour trips) from the intersection in question.
 - b. The project should install a street light on the north side of Prunedale South Road immediately west of the project driveway. The streetlight could be located outside the public right of way.
 - c. The project should install the following pavement markings.
 - i. A right turn arrow on the eastbound Prunedale South Road approach to US 101.
 - ii. A Type VI Lane Reduction Arrow in the southbound US acceleration lane approximately 100 feet north of Prunedale South Road, adjacent to the existing Type V directional arrows in the two southbound US 101 travel lanes.
 - iii. Double yellow centerline stripes on Prunedale South Road from the existing triangular island to the project driveway.
6. Monterey County should add delineators along the edge of the roadway at all three collision cluster locations on Prunedale South Road described in the collision analysis section of this letter.
7. Monterey County should relocate the existing speed limit signs on Prunedale South Road so that the 25-mph speed limit extends north of the horizontal curve approximately 1,050 feet north of Blackie Road.
8. Monterey County should consider adding advance warning and chevron signs at the horizontal curves on Prunedale South Road. If added, the project would be responsible for the cost of this improvement.
9. Monterey County should consider adding an additional northbound through signal head to inform northbound Prunedale South Road coming from Reese Circle regarding the current signal indication at the Prunedale South Road / Blackie Road intersection.
10. Monterey County should trim the foliage surrounding the existing culvert on Prunedale South Road immediately east of Prunedale North Road. This foliage obscures the existing warning signs adjacent to the culvert edge, thereby hiding the presence of the culvert from drivers on Prunedale South Road.
11. Monterey County should consider adding "Narrow Bridge" (W5-2) signs in advance of the culvert on Prunedale South Road.

Lawrence W. Horwitz, Esq.
August 14, 2020

If you have any questions regarding this letter or need additional information, please do not hesitate to contact me.

Thank you for the opportunity to assist you with this project.

Respectfully submitted,

Keith Higgins

Keith B. Higgins, PE, TE

Attachments

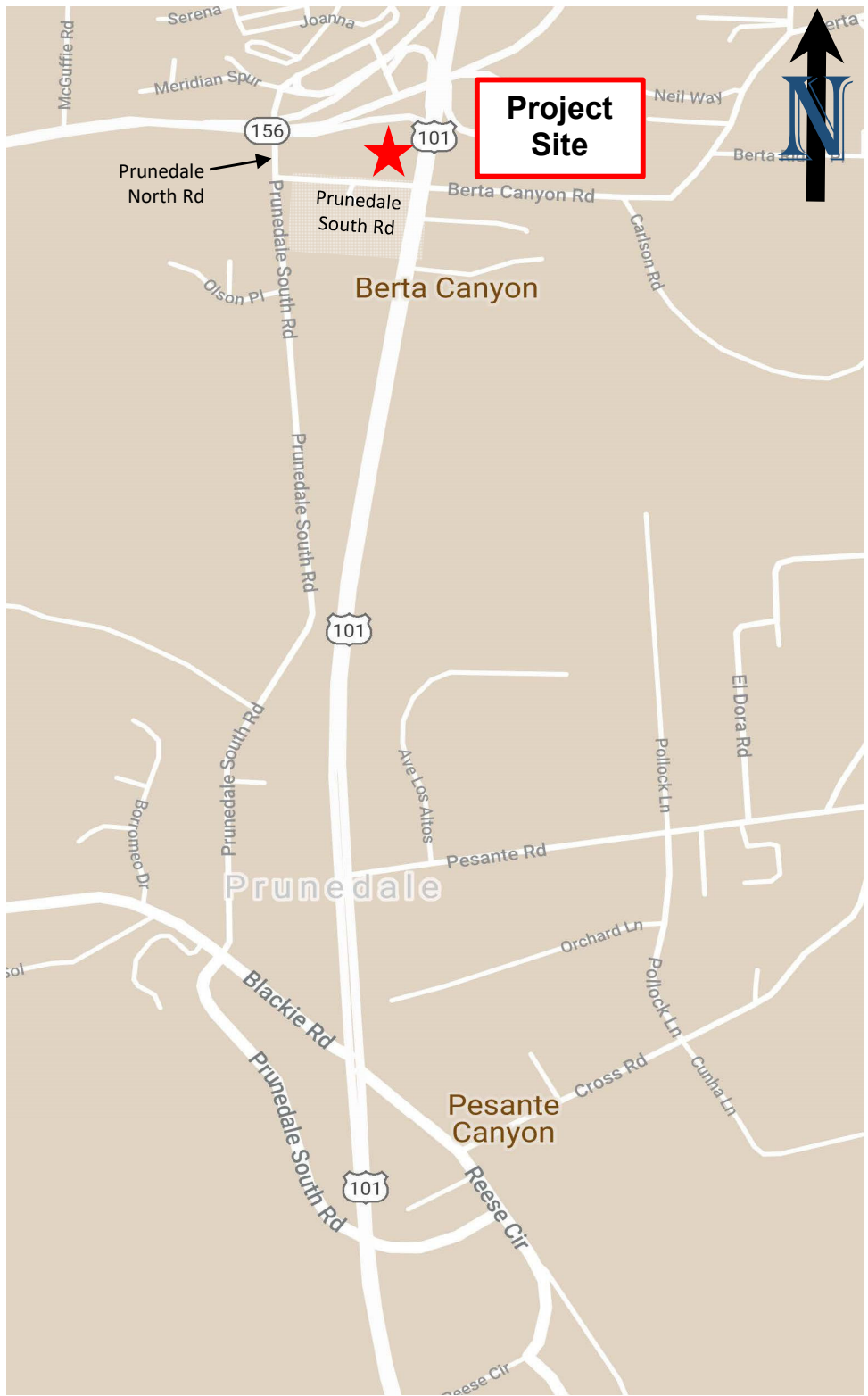

Basemap Source: Google Maps, 2020.

ITE Project No.	Size (SF)	Daily Trips	Daily Trip Rate per 1,000 SF	AM Trips	AM Trip Rate per 1,000 SF	PM Trips	PM Trip Rate per 1,000 SF	Sat. Daily Trips	Sat. Daily Trip Rate per 1,000 SF	Sat MD Trips	Sat MD Trip Rate per 1,000 SF
1	728	475	652	22	30.22	70	96.15	490	673.08	68	93.41
2	1,480	1,171	791	46	31.08	147	99.32	1261	852.03	177	119.59
3	3,000	260	87	18	6.00	35	11.67	229	76.33	35	11.67
4	3,411	272	80	4	1.17	37	10.85	245	71.83	38	11.14
5	630	x-x	x-x	x-x	x-x	3	4.76	x-x	x-x	x-x	x-x
6	950	x-x	x-x	x-x	x-x	15	15.79	x-x	x-x	x-x	x-x
7	1,250	x-x	x-x	x-x	x-x	12	9.60	x-x	x-x	x-x	x-x
8	1,060	x-x	x-x	x-x	x-x	10	9.43	x-x	x-x	x-x	x-x
9	1,065	x-x	x-x	x-x	x-x	12	11.27	x-x	x-x	x-x	x-x
10	1,740	x-x	x-x	x-x	x-x	26	14.94	x-x	x-x	x-x	x-x
11	2,750	x-x	x-x	x-x	x-x	35	12.73	x-x	x-x	x-x	x-x
12	2,870	x-x	x-x	x-x	x-x	60	20.91	x-x	x-x	x-x	x-x
ITE Average	8,619	2178	252.70	90	10.44			2,225	259.31	318	36.43
ITE Average without Projs. 1 & 2	6,411	532	83.0	22	3.43			474	73.94	73	11.39
ITE Average (PM Only)	20,934					462	21.83				
ITE Average without Projs. 1 & 2 (PM Only)	18,726					245	13.08				
Emerald Skyway	4,200	284	67.6	5	1.19	41	9.76	N.A.	N.A.	N.A.	N.A.

Abundant Investments Based on ITE without Projects 1&2	1,413	96	67.6	2	1.19	42	29.39	104	73.94	42	29.39
Abundant Investments Based on Emerald Skyway	1,413			5	3.43	18	13.08			16	11.39

Sources: 1. ITE Data - "Trip Generation Manual," Insitute of Transportation Engineers, 10th Edition, 2017
2. Emerald Skyway - Raw traffic counts included in Appendix A.

TRIP GENERATION RATES			WEEKDAY								
ITE CODE	ITE CATEGORY	COUNTY ZONING	DAILY TRIP RATE	AM PEAK HOUR			PM PEAK HOUR				
				PEAK HOUR RATE	% OF ADT	% IN	% OUT	PEAK HOUR RATE	% OF ADT	% IN	% OUT
COUNTY ADMINISTRATIVE PERMIT ONLY											
710	Office	Office	14.87	1.15	8%	89%	11%	1.54	10%	16%	84%
811	Construction Equipment Rental	Irrigation Equip.	17.50	1.4	8%	28%	72%	1.75	10%	40%	60%
814	Variety Store	Book Store	63.47	3.18	5%	57%	43%	6.84	11%	52%	48%
		Photography Studio	63.47	3.18	5%	57%	43%	6.84	11%	52%	48%
		Florist	63.47	3.18	5%	57%	43%	6.84	11%	52%	48%
		Locksmith	63.47	3.18	5%	57%	43%	6.84	11%	52%	48%
		Bicycle Shop	63.47	3.18	5%	57%	43%	6.84	11%	52%	48%
		Pet Shop	63.47	3.18	5%	57%	43%	6.84	11%	52%	48%
		Stationery Supply	63.47	3.18	5%	57%	43%	6.84	11%	52%	48%
816	Hardware/Paint	Hardware Store	9.14	1.08	12%	50%	50%	1.08	12%	50%	50%
851	Convenience Market	Convenience Mkt.	762.28	62.54	8%	50%	50%	49.11	6%	51%	49%
858	Farmers Market (1.79 acres)	Open air retail sales	174.90	8.745	5%	57%	43%	19.24	11%	52%	48%
876	Apparel Store	Clothing/Apparel	66.40	1	2%	80%	20%	4.12	6%	51%	49%
		Shoe Shop/Store	66.40	1	2%	80%	20%	4.12	6%	51%	49%
879	Arts & Crafts Store	Art Gallery	56.55	4.65	8%	49%	51%	6.21	11%	46%	54%
		Stationery	56.55	4.65	8%	49%	51%	6.21	11%	46%	54%
		Picture Framing	56.55	4.65	8%	49%	51%	6.21	11%	46%	54%
880	Pharmacy/Drug Store	Drug Store	90.08	2.94	3%	65%	35%	8.51	9%	49%	51%
890	Furniture Store	Appliance Store	6.30	0.26	4%	71%	29%	0.52	8%	47%	53%
911	Banks less than 5,000 s.f.	Walk-in Bank	121.30	10.34	9%	52%	48%	12.13	10%	51%	49%
918	Hair Salon (814-Variety Store)	Barber Shop	63.47	3.18	5%	57%	43%	6.84	11%	52%	48%
		Beauty Shop	63.47	3.18	5%	57%	43%	6.84	11%	52%	48%
USE PERMIT REQUIRED											
560	Church	Church	9.77	2.06	21%	57%	43%	6.84	70%	52%	48%
565	Day Care Center	Day Care Center	47.62	11	23%	53%	47%	11.12	23%	52%	48%
640	Animal Hospital	Animal Hospital	21.50	3.64	17%	67%	33%	3.53	16%	40%	60%
841	Auto Sales - Used	Auto Sales - Used	27.06	2.13	8%	76%	24%	3.75	14%	47%	53%
930	Fast Casual	Restaurant	315.47	2.07	1%	67%	33%	14.13	4%	55%	45%

PROJECT SITE TRIP GENERATION			WEEKDAY								
ITE CODE	ITE CATEGORY	COUNTY ZONING	DAILY TRIPS	AM PEAK HOUR			PM PEAK HOUR				
				PEAK HOUR TRIPS	% OF ADT	TRIPS IN	TRIPS OUT	PEAK HOUR TRIPS	% OF ADT	TRIPS IN	TRIPS OUT
Abundant Investments Cannabis	Cannabis Retailer	Cannabis Retailer	139	5	4%	4	1	18	13%	9	9
COUNTY ADMINISTRATIVE PERMIT ONLY											
710	Office	Office	21	2	8%	1	1	2	10%	0	2
811	Construction Equipment Rental	Irrigation Equip.	25	2	8%	1	1	2	10%	1	1
814	Variety Store	Book Store	90	4	5%	3	1	10	11%	5	5
		Photography Studio	90	4	5%	3	1	10	11%	5	5
		Florist	90	4	5%	3	1	10	11%	5	5
		Locksmith	90	4	5%	3	1	10	11%	5	5
		Bicycle Shop	90	4	5%	3	1	10	11%	5	5
		Pet Shop	90	4	5%	3	1	10	11%	5	5
		Stationery Supply	90	4	5%	3	1	10	11%	5	5
816	Hardware/Paint	Hardware Store	13	2	12%	1	1	2	12%	1	1
851	Convenience Market	Convenience Mkt.	1,077	88	8%	44	44	69	6%	35	34
858	Farmers Market	Open air retail sales	247	12	5%	7	5	27	11%	14	13
876	Apparel Store	Clothing/Apparel	94	1	2%	1	0	6	6%	3	3
		Shoe Shop/Store	94	1	2%	1	0	6	6%	3	3
879	Arts & Crafts Store	Art Gallery	80	7	8%	3	4	9	11%	4	5
		Stationery	80	7	8%	3	4	9	11%	4	5
		Picture Framing	80	7	8%	3	4	9	11%	4	5
880	Pharmacy/Drug Store	Drug Store	127	4	3%	3	1	12	9%	6	6
890	Furniture Store	Appliance Store	9	0	4%	0	0	1	8%	0	1
911	Banks less than 5,000 s.f.	Walk-in Bank	171	15	9%	8	7	17	10%	9	8
918	Hair Salon (814-Variety Store)	Barber Shop	90	4	5%	3	1	10	11%	5	5
		Beauty Shop	90	4	5%	3	1	10	11%	5	5
USE PERMIT REQUIRED											
560	Church	Church	14	3	21%	2	1	10	70%	5	5
565	Day Care Center	Day Care Center	67	16	23%	8	8	16	23%	8	8
640	Animal Hospital	Animal Hospital	30	5	17%	3	2	5	16%	2	3
841	Auto Sales - Used	Auto Sales - Used	38	3	8%	2	1	5	14%	2	3
930	Fast Casual	Restaurant	446	3	1%	2	1	20	4%	11	9

Notes:

1. Trip generation rates published by Institute of Transportation Engineers (ITE), *Trip Generation Manual*, 10th Edition, 2017.
2. Project building trip generation is based on a building floor area of 1,413 gross square feet for all alternative uses.

Collision Summary
2. US 101 Southbound / Prunedale South Road
2015-2019

Collision Number	Collision Date	Collision Type	No. of Fatalities	No. of Injuries	Primary Collision Factor	Any of the Following Involved?			Weather
						Pedestrian	Bicycle	Motorcycle	
1.	7/3/2015	Hit Object	1	0	Improper Turning	No	No	No	Clear
2.	5/15/2015	Rear End	0	3	Unsafe Speed	No	No	No	Clear
3.	9/25/2015	Rear End	0	1	Unsafe Speed	No	No	No	Clear
4.	4/6/2017	Rear End	0	2	Unsafe Speed	No	No	No	Clear
5.	8/1/2017	Rear End	0	1	Unsafe Speed	No	No	No	Clear
6.	9/5/2017	Sideswipe	0	1	Unsafe Speed	No	No	No	Clear
7.	4/3/2018	Rear End	0	1	Unsafe Speed	No	No	No	Clear
8.	9/30/2018	Broadside	0	1	Driving While Intoxicated	No	No	No	Clear
9.	12/21/2018	Rear End	0	1	Unsafe Speed	No	No	No	Clear

Total:	9	1	11
Per Year:	1.80	0.20	2.20

Collision Frequency:

Collision Type	Total	Per Year
Hit Object	1	0.2
Rear End	6	1.2
Sideswipe	1	0.2
Broadside	1	0.2

Primary Collision Factor Frequency:

Collision Factor	Total	Per Year
Improper Turning	1	0.2
Unsafe Speed	7	1.4
Driving While Intoxicated	1	0.2

Data Source: Transportation Injury Mapping System (TIMS), University of California Berkeley. Data obtained July 22, 2020. TIMS data excludes Property Damage Only (PDO) collisions.

Collision Diagram

Intersection: 2. Southbound US 101 / Prunedale South Road

Time Period: January 1, 2015 - December 31, 2019

Location: Prunedale

County: Monterey

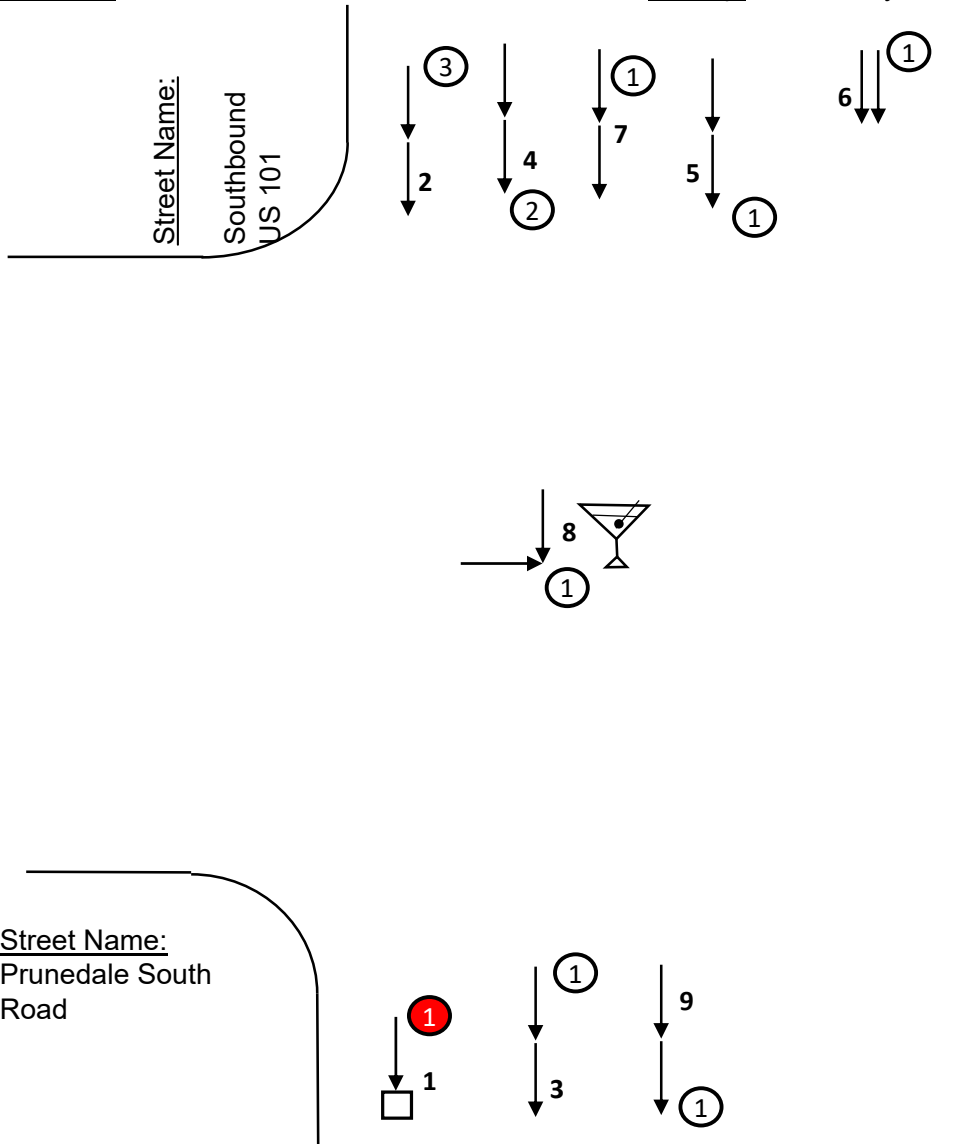

Total Collisions:
9 collisions in
5 years

Street Name:
Prunedale South
Road

Street Name:
Southbound
US 101

Symbols:

- Left
- Through
- Right
- Stopped
- Parked
- Overtaken
- Backing
- Animal

- Pedestrian
- Bicycle
- DUI
- Collision
- Number

Types of Collisions:

- Head On
- Broadside
- Rear End
- Sideswipe
- Fixed Object
- Other

Severity:

- Fatal
- Injury

Collision Summary
 Prunedale South Road between Prunedale North Road and Blackie Road
 2013-2018

Collision Number	Collision Date	Collision Type	No. of Fatalities	No. of Injuries	Primary Collision Factor	Any of the Following Involved?			Weather
						Pedestrian	Bicycle	Motorcycle	
1.	2/21/2013	Rear-End	0	1	Unsafe Starting/Backing	No	No	No	Clear
2.	2/22/2013	Hit Object	0	0	Improper Turning	No	No	No	Clear
3.	9/18/2013	Vehicle-Pedestrian	0	1	Unknown	Yes	No	No	Clear
4.	11/19/2014	Hit Object	0	0	Improper Turning	No	No	No	Raining
5.	1/14/2015	Hit Object	0	0	Improper Turning	No	No	No	Clear
6.	4/7/2015	Hit Object	0	0	Improper Turning	No	No	No	Raining
7.	6/15/2015	Hit Object	0	0	Improper Turning	No	No	No	Clear
8.	10/26/2015	Broadside	0	0	Auto Right-of-Way	No	No	No	Clear
9.	12/31/2015	Overtuned	0	1	Improper Turning	No	No	No	Clear
10.	11/23/2016	Broadside	0	1	Auto Right-of-Way	No	No	No	Clear
11.	1/12/2017	Hit Object	0	0	Improper Turning	No	No	No	Cloudy
12.	1/26/2017	Hit Object	0	1	Improper Turning	No	No	No	Clear
13.	5/1/2017	Hit Object	0	0	Improper Turning	No	No	No	Clear
14.	9/26/2017	Hit Object	0	0	Improper Turning	No	No	No	Clear
15.	10/12/2017	Broadside	0	2	Unknown	No	No	No	Clear
16.	10/23/2017	Hit Object	0	0	Other Equipment	No	No	No	Clear
17.	12/12/2018	Hit Object	0	0	Improper Turning	No	No	No	Clear

Total:	17	0	7
Per Year:	2.83	0.00	1.17

Collision Frequency:

Collision Type	Total	Per Year
Rear-End	1	0.17
Hit Object	11	1.83
Vehicle-Pedestrian	1	0.17
Broadside	3	0.5
Overtuned	1	0.17

Primary Collision Factor Frequency:

Collision Factor	Total	Per Year
Unsafe Starting/Backing	1	0.17
Improper Turning	11	1.83
Unknown	2	0.33
Auto Right-of-Way	2	0.33
Other Equipment	1	0.17

Data Source: Monterey County Public Works Department.

Collision Diagram

Segment Prunedale South Rd between Prunedale North Rd and Blackie Rd
Time Period: January 1, 2013 - December 31, 2018
Location: Prunedale County: Monterey



Total Collisions:
17 collisions in
6 years

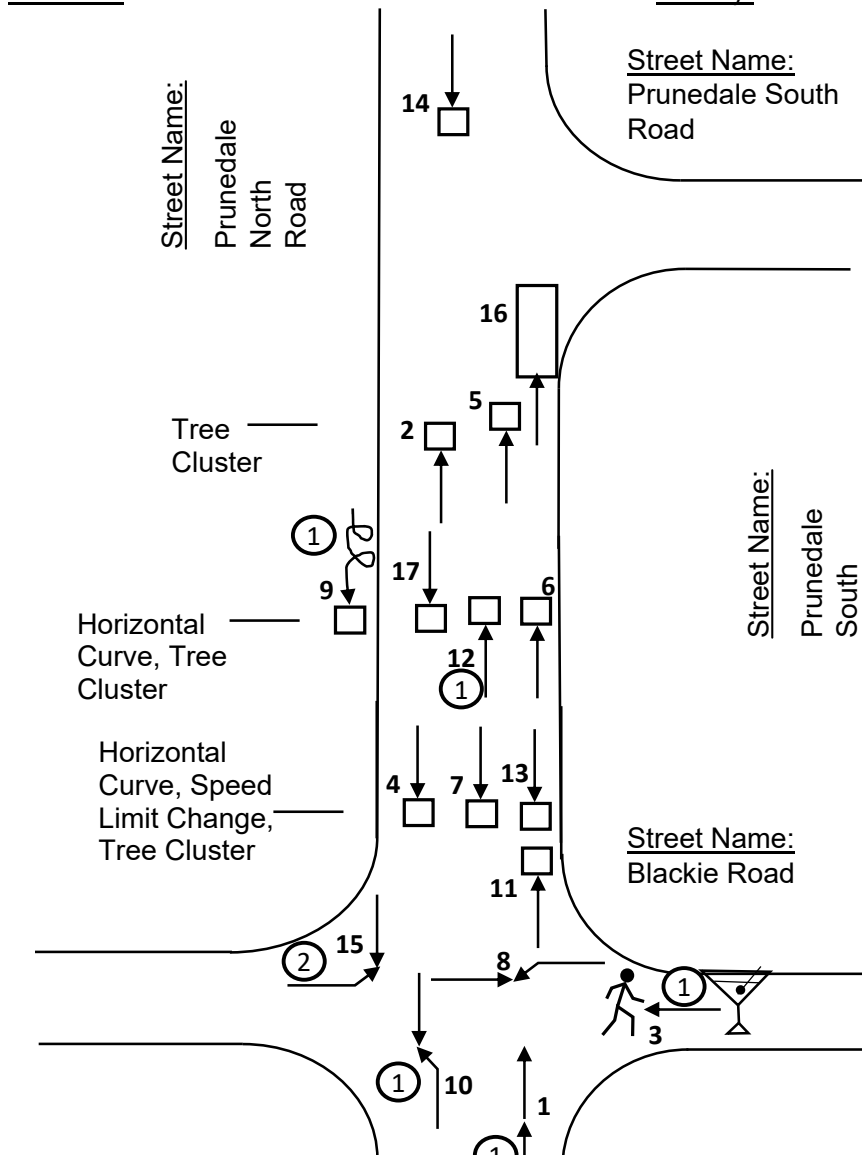

Symbols:

- | | | | |
|-----------|--|------------|--|
| Left | | Pedestrian | |
| Through | | Bicycle | |
| Right | | DUI | |
| Stopped | | Collision | |
| Parked | | Number | |
| Overtaken | | | |
| Backing | | | |
| Animal | | | |

Types of Collisions:

- | | |
|--------------|--|
| Head On | |
| Broadside | |
| Rear End | |
| Sideswipe | |
| Fixed Object | |
| Other | |

Severity:

- | | |
|--------|--|
| Fatal | |
| Injury | |

Note: Not To Scale

Exhibit ?
**Collision Diagram for
 Prunedale South Road
 between Prunedale North Road and Blackie Road**

1. Prunedale South Road - Prunedale North Road / Prunedale South Road

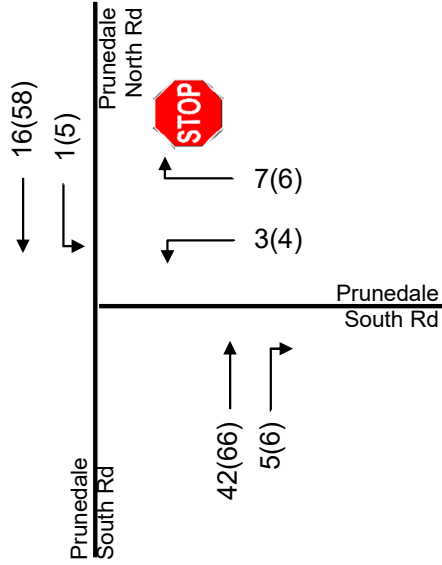

2. Southbound US 101 / Prunedale South Road

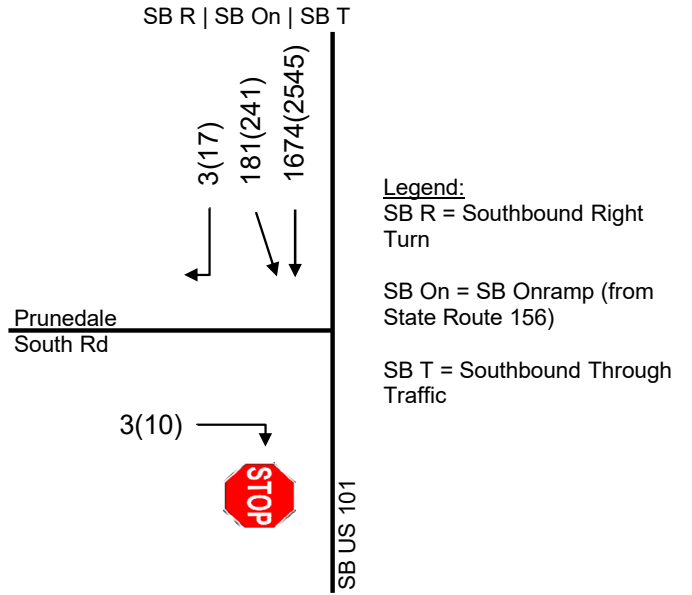

3. Prunedale South Road / Blackie Road

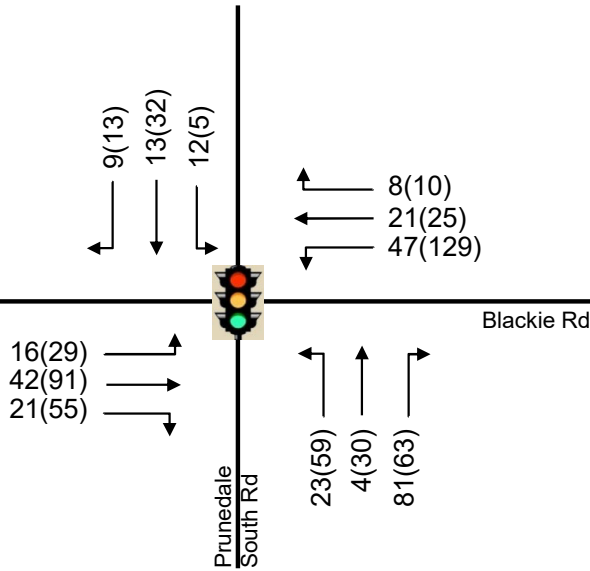

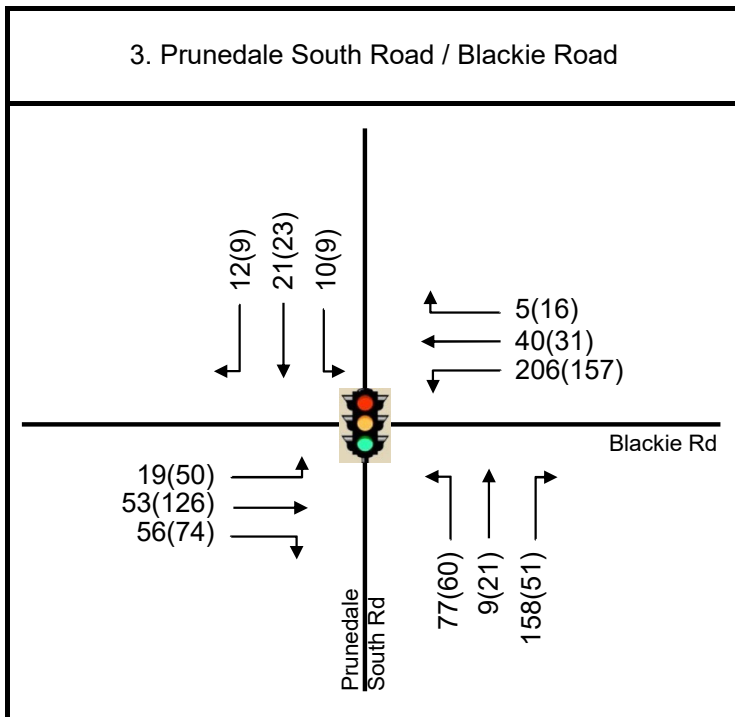
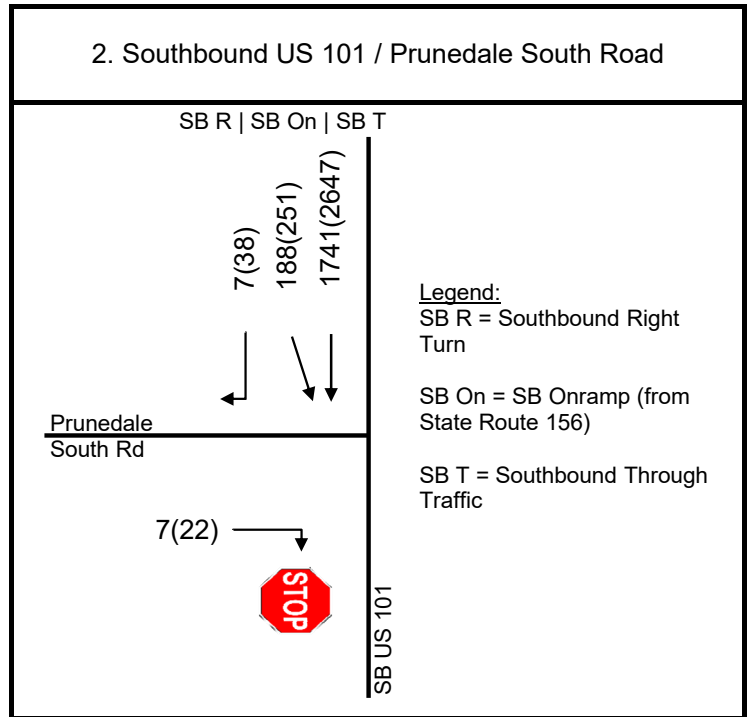
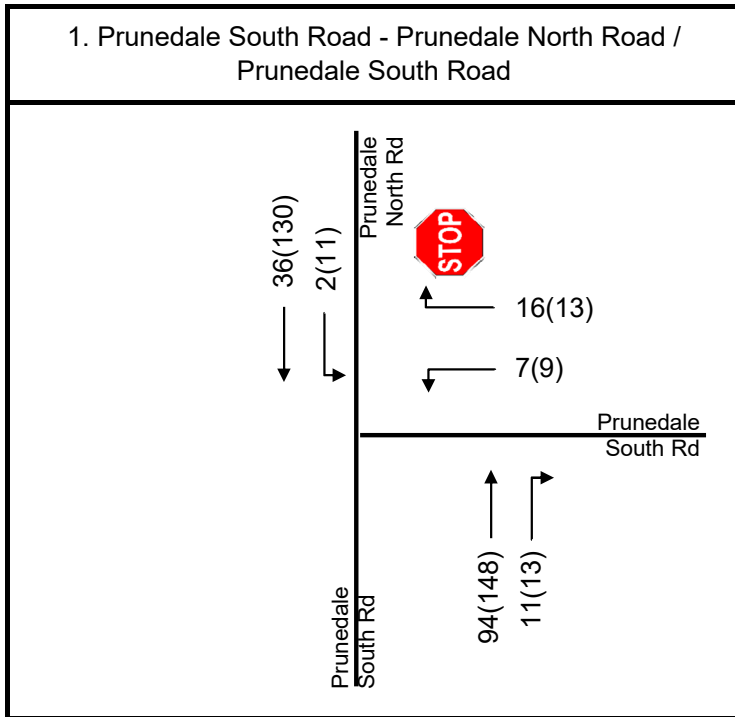

Source:
 1. Prunedale South Road / Blackie Road - *La Tourette Subdivision Traffic Impact Analysis*, Keith Higgins Traffic Engineer, October 4, 2017
 2. Intersections 1 and 2 volumes include growth factors based on Intersection 3 volumes

N-S Street	E-W Street	Jurisdiction	Existing Lane Configuration	Existing Intersection Control	LOS Standard	Peak Hour	Existing Conditions		Existing Plus Project Conditions	
							Delay	LOS	Delay	LOS
1 Prunedale South Road - Prunedale North Road	Prunedale South Road	Monterey County	NB 1-T/R SB 1-L/T WB 1-L/R	One-Way Stop	E	AM	9.2	A	9.2	A
						PM	10.2	B	10.4	B
						AM	<i>With Improvement</i>			
2 Southbound US 101	Prunedale South Road	Caltrans	SB 1-T/R ¹² EB 1-R	One-Way Stop	C-D	AM	9.4	A	9.4	A
						PM	9.9	A	10.0	B
3 Prunedale South Road	Blackie Road	Monterey County	NB 1-L, 1-T/R SB 1-L, 1-T/R EB 1-L, 1-T, 1-R WB 1-L, 1-T/R	Signal ¹³	D	AM	16.4	B	16.4	B
						PM	17.1	B	17.0	B

Notes:

1. L, T, R = Left, Through, Right.
2. NB, SB, EB, WB = Left, Through, Right, Northbound, Southbound, Eastbound, Westbound.
3. N/A = Not Applicable. This intersection does not exist under this scenario.
4. Overall level of service standard for Monterey County is LOS D. Side-street level of standard assumed as LOS E.
5. Overall Caltrans level of service standard is the transition between LOS C and LOS D, abbreviated as "LOS C-D".
6. For signalized and all-way stop intersection analysis, delay is average overall delay in seconds per vehicle (sec/veh).
7. For one- and two-way stop intersections, delays are side-street approach operations, also in seconds per vehicle (sec/veh).
8. Analysis performed using 2010 Highway Capacity Manual methodologies.
9. Level of service calculations can be found in **Appendix F**.
10. LOS highlighted in **red** indicates intersection operating below level of service standard.
11. LOS with a thick black border represents a significant local adverse effect. Resulting levels of service with recommended improvements noted under "With Improvements".
A list of applied improvements can be found on **Exhibit 11**.
12. Lane configuration reflects the channelization at this intersection, which results in only the single southbound US 101 merge lane conflicting with eastbound Prunedale South Road right turn movement.

N-S Street	E-W Street	Jurisdiction	Existing Conditions	Existing Plus Project Conditions
1 Prunedale South Road - Prunedale North Road	Prunedale South Road	Monterey County	None Required	None Required
2 Southbound US 101	Prunedale South Road	Caltrans	None Required	None Required
3 Prunedale South Road	Blackie Road	Monterey County	Consider additional Northbound Prunedale South Signal Head for better advance signal visibility	None Required

Notes:

1. L, T, R = Left, Through, Right.
2. NB, SB, EB, WB = Northbound, Southbound, Eastbound, Westbound.
3. N/A = Not Applicable. This intesection does not exist under this scenario.

1. Prunedale South Road - Prunedale North Road / Prunedale South Road

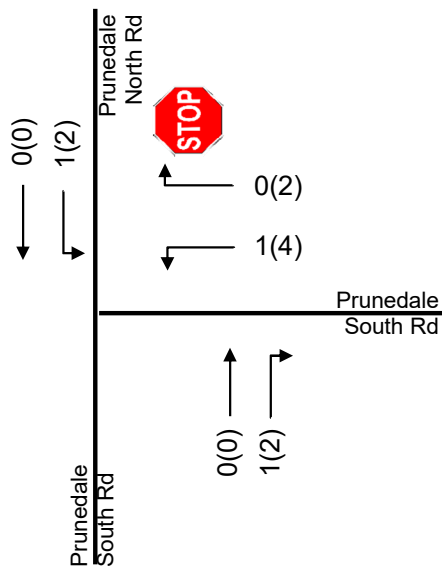

2. Southbound US 101 / Prunedale South Road

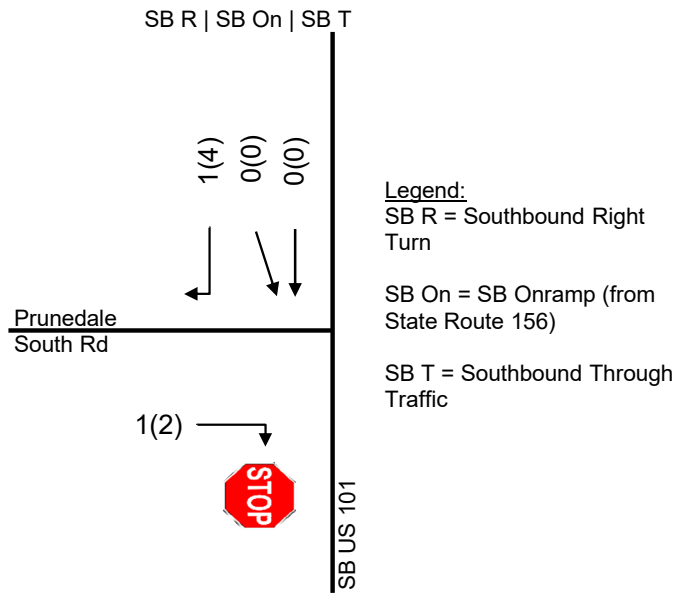

3. Prunedale South Road / Blackie Road

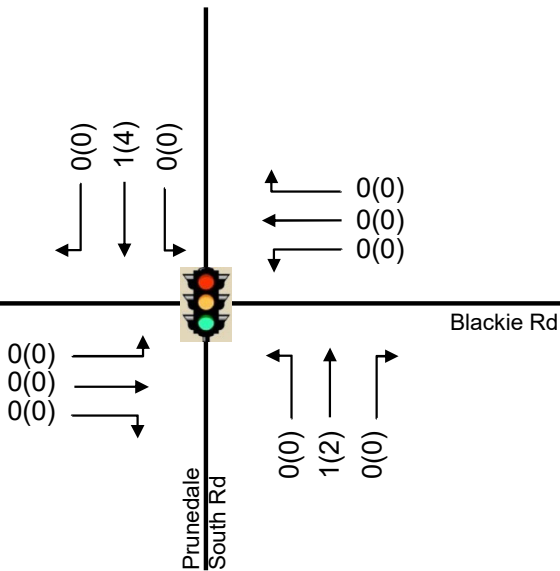

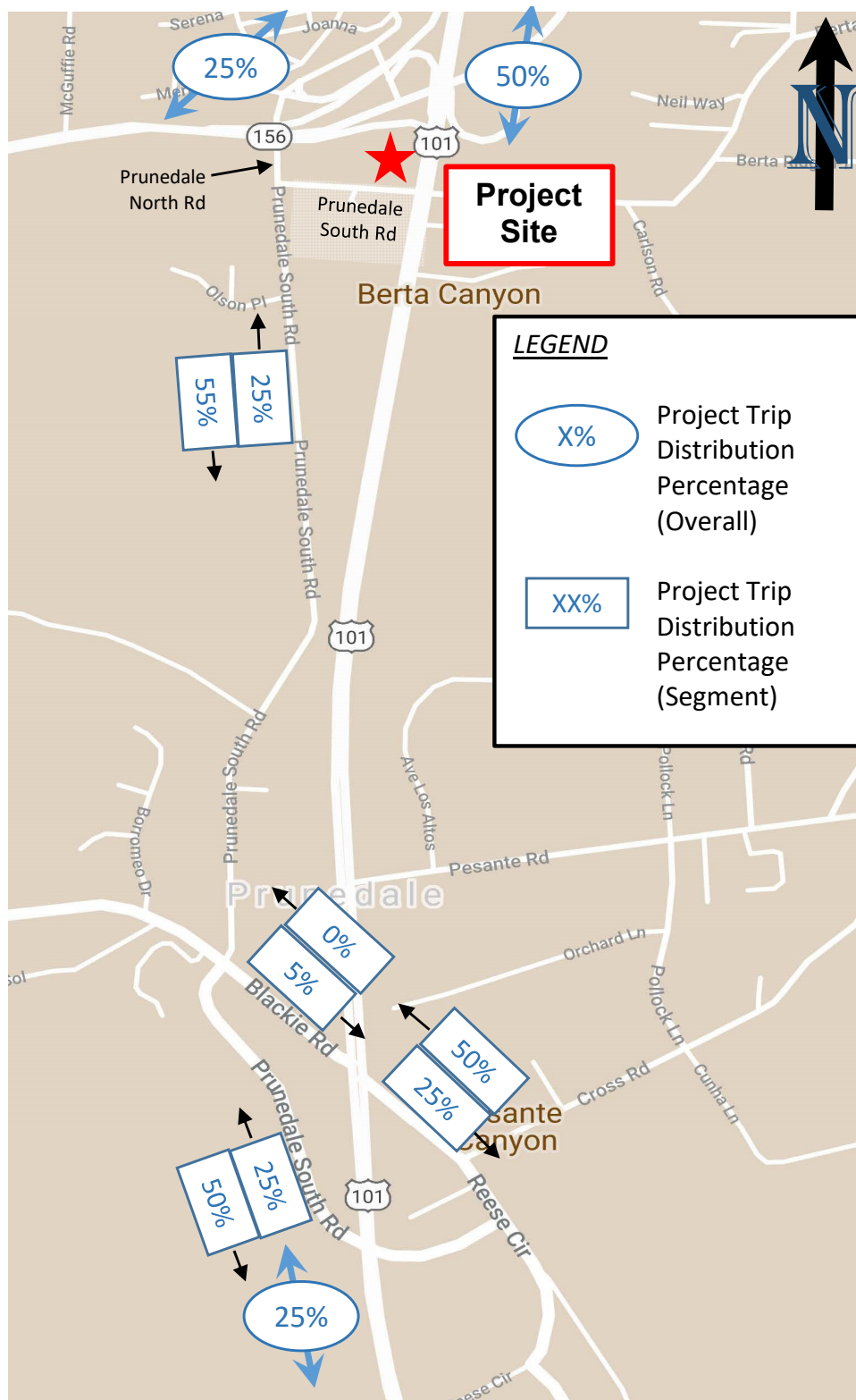

Basemap Source: Google Maps, 2020.

1. Prunedale South Road - Prunedale North Road / Prunedale South Road

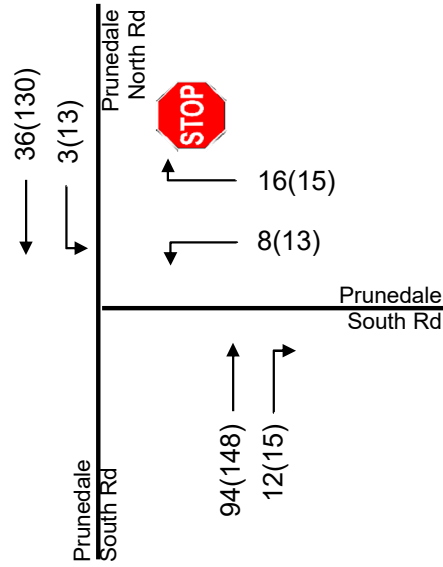

2. Southbound US 101 / Prunedale South Road

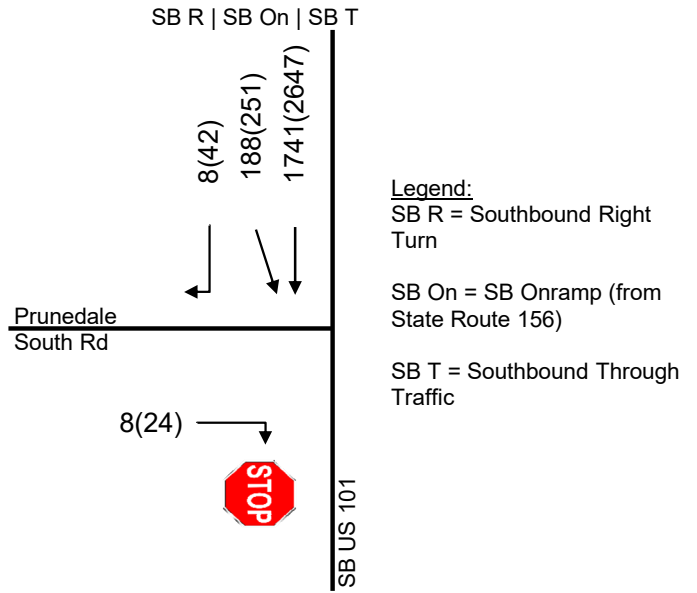

3. Prunedale South Road / Blackie Road

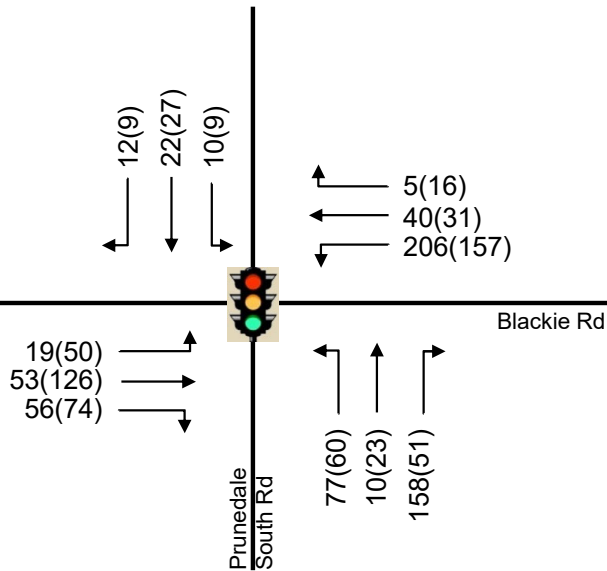

Appendix A

Email from

Monterey County Public Works Department

Dated July 24, 2020

Keith Higgins

From: Fernandez, Armando x4873 <FernandezA2@co.monterey.ca.us>
Sent: Friday, July 24, 2020 2:19 PM
To: Keith Higgins
Cc: Alinio, Chad S. x4937; Pham-Gallardo, Son x5226; Hernandez, Juan x4923
Subject: PLN190008_Abundant Investments Traffic Control

Hi Keith – This is a follow up to our conference call earlier this week. Public Works appreciate the opportunity to comment and we offer the following recommendations to aid you with the application process:

SECTION A: PROJECT SITE TRIP GENERATION

- *Provide summary table indicating the project's total number of trips per day. Note the initial estimate provided during planning commission was 354 trips per ITE manual.*

SECTION B: ACCIDENT HISTORY

- *Provide collision diagram(s) for Prunedale South Road, from the project driveway to Blackie Road. The 2015-2019 span should be sufficient to be consistent with your Exhibit 3.*

SECTION C: TRAFFIC INCREASES ON NEARBY ROADS

- *Provide traffic trip distribution diagram for the tee intersection of Prunedale South and Prunedale North.*
- *Include a summary clarifying if the increase in trips would have minimal impact to the nearby roadway system – based on review your report, it seems that is what you are reporting, but it does not seem to be clear.*

SECTION D: SUMMARY AND RECOMMENDATIONS

- Section 5b. Please reassess the proposed location of the street light, possibly to a location west of the project driveway, just outside the public right of way, on the north side of Prunedale South Road. As we discussed, there may be other options and opportunities for the location of safety lighting, instead of on the PG&E pole.

Armando Fernandez
County of Monterey
Resource Management Agency
1441 Schilling Place, 2nd Floor
Salinas CA 93901
Ph: (831) 755-4873
FernandezA2@co.monterey.ca.us

Appendix B

Emerald Skyway

Traffic Count

EMERALD SKYWAY			
TRAFFIC COUNT			
1610 Moffett Street, Salinas, CA			
Thursday, May 31, 2018			
BEGIN			
TIME	IN	OUT	TOTAL
9:00 AM	4	1	5
10:00 AM	5	4	9
11:00 AM	11	8	19
12:00 PM	12	13	25
1:00 PM	7	10	17
2:00 PM	8	5	13
3:00 PM	13	16	29
4:00 PM	22	9	31
5:00 PM	17	24	41
6:00 PM	22	19	41
7:00 PM	14	21	35
8:00 PM	3	12	15
9:00 PM	0	0	0
TOTAL	138	142	280
ASSUMING ENTERING TRAFFIC OCCURRED BEFORE THE COUNT BEGAN, IT WOULD EQUAL THE OUTBOUND TOTAL, OR 142. THE DAILY TOTAL WOULD THEN BE.....			284

Appendix C

Ascend Mass, LLC

Proposed Registered Marijuana Dispensary

Traffic Impact Statement

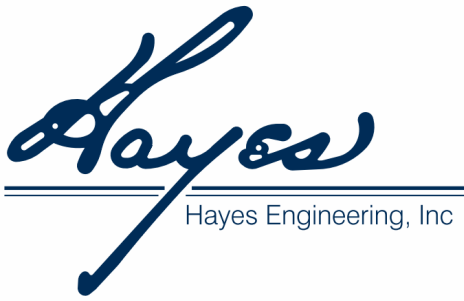

603 Salem Street
Wakefield, MA 01880
Tel: (781) 246-2800
Fax: (781) 246-7596

Traffic Impact Statement

Internal Draft

Nantucket, MA 02554
Tel: (508) 228-7909

Refer to File No. CAM-0042

TO: City of Cambridge Planning Board
FROM: Tony Capachietti, *Project Manager*
DATE: September 6, 2018
Revised October 28, 2018
October 31, 2018
SUBJECT: Ascend Mass, LLC
Proposed Registered Marijuana Dispensary
200 Monsignor O'Brien Highway
Cambridge, MA

Hayes Engineering, Inc. (HEI) has prepared the following Traffic Impact Statement in support of the proposed Registered Marijuana Dispensary (RMD) at the above address in accordance with section 11.803(c) of the City's Zoning Ordinance. This statement was prepared on behalf of the project proponent, Ascend Mass, LLC. The purpose of this Impact Statement is two-fold:

- To estimate the intensity, frequency and mode of transportation for client and employee trips to the proposed RMD; and
- To identify the frequency and scale of deliveries to and from the site.

The existing building located at the southeasterly corner of the intersection between Monsignor O'Brien Highway (Route 28) and Third Street in East Cambridge. The existing two-story, approximately 5,100-sf., brick structure is currently occupied by Lechmere Rug, a carpet retailer and installer.

Site Accessibility

The proposed RMD is located on the southerly side of Monsignor O'Brien Highway at its intersection with Third Street in the neighborhood of East Cambridge. Off-street parking is available adjacent to the building in an existing seven (7) space parking lot on the property. On-street parking is limited in the vicinity of the building. Public parking is available at the nearby pay lots on First Street and Canal Park.

The proposed RMD is readily accessible via the MBTA subway and is within 700-feet of the Lechmere Green Line stop.

The site is also located conveniently to four (4) MBTA bus routes and is within 500-feet of stops for the 69, 80, 87 and 88 routes.

The proponent intends to encourage both patients and employees to utilize alternative modes of transportation to minimize project impacts on both parking and traffic.



Trip Generation

Average Daily Vehicle Trips and Peak Hour Trips for the project are calculated using data published by the Institute of Transportation Engineers (ITE) Trip Generation Manual, 10th Edition, supplemented with survey data from an existing RMD operating in the City of Cambridge.

Existing Condition:

The previous use at the facility is best classified by ITE Land Use Code (LUC) 180 – Specialty Trade Contractor:

A specialty trade contractor is a business primarily involved in providing contract repairs and services to meet industrial or residential needs. This land use includes businesses that provide the following services: plumbing, heating and cooling, machine repair, electrical and mechanical repair, industrial supply, roofing, locksmith, weed and pest control, and cleaning.

Estimated Trip Generation rates for the existing 5,100± square foot (sf.) facility under its prior use are summarized in Table 1, below. ITE Trip Generation Graphs for the above Land Use Code accompanies this report as Appendix A.

TABLE 1
 Trip Generation, *Prior Use*

<u>Time Period/Direction</u>	<u>LUC 180 – Specialty Trade Contractor Vehicle Trip Ends⁽¹⁾</u>
Weekday Daily	52
Weekday AM Peak Hour	10
Weekday PM Peak Hour	11
Saturday Daily	Not Published

⁽¹⁾ Based on 5,100± sf of floor area

Proposed Condition:

The proposed RMD use is best classified as Institute of Transportation Engineers (ITE) Land Use Code (LUC) 882, Marijuana Dispensary, defined in the ITE Trip Generation Manual, 10th Edition as being:

... a standalone facility where cannabis is sold to patients or consumers in a legal manner.

Trip Generation rates for the proposed 5,100± sf. RMD are summarized in Table 2, below. ITE Trip Generation Graphs for Land Use Code 882 accompany this report as Appendix B. It



should be noted that the ITE cautions the use of this data as it is from a small sample set and the proposed RMD size is outside of the ITE study range.

TABLE 2

Trip Generation, *Proposed Use*

<u>Time Period/Direction</u>	<u>LUC 882 – Marijuana</u>
	<u>Dispensary</u>
	<u>Vehicle Trip Ends⁽¹⁾</u>
Weekday Daily	1,289
Weekday AM Peak Hour	106
Weekday PM Peak Hour	153
Saturday Daily	1,322

⁽¹⁾ Based on 5,100± sf of floor area

The ITE numbers resulted in excessive and unbelievable trip estimates and were checked against real data from point of sales for customer counts from an existing and operating 1,600-sf. RMD in the Harvard Square section of Cambridge. The facility was surveyed during the month of February 2018 and averaged 21 customers per day, an average rate of 13.13 customers per 1,000-sf. Using this observed data, the proposed 5,100-sf. Ascend dispensary is anticipated to serve approximately 67 medical customers daily with an additional 3 employees at the site.

Not all of the vehicle trips anticipated by the proposed dispensary represent new trips. It is anticipated that many customers to the facility will be pass-by, pedestrian or public transit riders and the facility will have minimal impacts to vehicle traffic conditions in the area. Studies have shown that for developments such as the proposed dispensary a substantial portion of vehicle trips are from existing traffic passing by the site or diverted from another route to a the proposed site. Data presented in the ITE Trip Generation Handbook indicates that for the average percentage of pass-by trips for Pharmacy/Drugstores without Drive-Through Windows is 49-percent during the weekday PM peak hour.

The City of Cambridge provides access to a robust public transit system and actively encourages the use of alternative modes of transportation. The proposed use is not anticipated to cause a significant change to existing mode splits in the vicinity. The Proponent seeks to encourage the use of alternative modes of transportation among its employees and customers.

Deliveries

Ascend anticipates approximately eleven (11) deliveries to and/or from the RMD per week. Deliveries to the site will consist of marijuana and marijuana containing products every other day, up to four (4) times per week. This includes the delivery of product and removal of marijuana containing waste for disposal at Ascend's cultivation and processing facility. Cash will be picked up daily from the facility or upon reaching a monetary threshold up to seven (7) times per week.



Traffic Impact Statement

Ascend Mass, LLC
200 Monsignor O'Brien Highway
CAM-0043
September 6, 2018
Revised October 28, 2018
October 31, 2018

Internal Draft

Deliveries will be conducted in accordance with provisions of the Security Plan on file with the Department of Public Health and shall occur at random times outside of normal business hours (between the hours of 9pm and 11am). Deliveries will use off-street parking adjacent to the facility.

Parking:

The proposed dispensary will use existing the existing off-street parking lot adjacent the building to provide parking for four (4) vehicles and one (1) handicap plate/placard vehicle (van accessible). The parking lot will also include eight (8) bicycle racks that will accommodate sixteen (16) bicycles for use within the lot, one rack will be dedicated to employee bicycle parking. Ascend will provide indoor bike lockers for employee use.

Mitigation:

Although the Applicant does not anticipate that the proposed dispensary use will result in any adverse traffic impacts, the Applicant is willing to undertake any of the following traffic mitigation efforts to protect against adverse effects:

- Provide 65% MBTA T-Pass subsidies, up to the federal fringe benefit, to all employees, with a pro-rated incentive for any part-time employees;
- Provide lockers in the break room for employees that walk or bike to work;
- Compile and provide to all employees, including during employee orientation, up to date transportation information explaining all commuter options;
- Provide employees a gold level Bluebikes membership to encourage employee use of alternatives to single-occupancy vehicles for commuting.
- Provide customers with information regarding transportation options to access the facility;
- Provide and maintain information on the Applicant's website and other distributed material on how to access the facility by all modes of transportation, with an emphasis on non-automobile modes;
- Participate in transportation-related training offered by the City of Cambridge or a local Transportation Management Association; or
- Designate a Transportation Coordinator to develop and manage the implementation of a Transportation Demand Management plan.

Appendix D

CREC Compliance

Cannabis Industry Market Study



Since the legalization of recreational marijuana in California (2018), the regulated cannabis industry (“Industry”) brought in \$2.5B to retail dispensary and delivery; since then, the Industry has been steadily increasing with its most recent jump of approximately fourteen percent (14%) from 2018 to 2019:

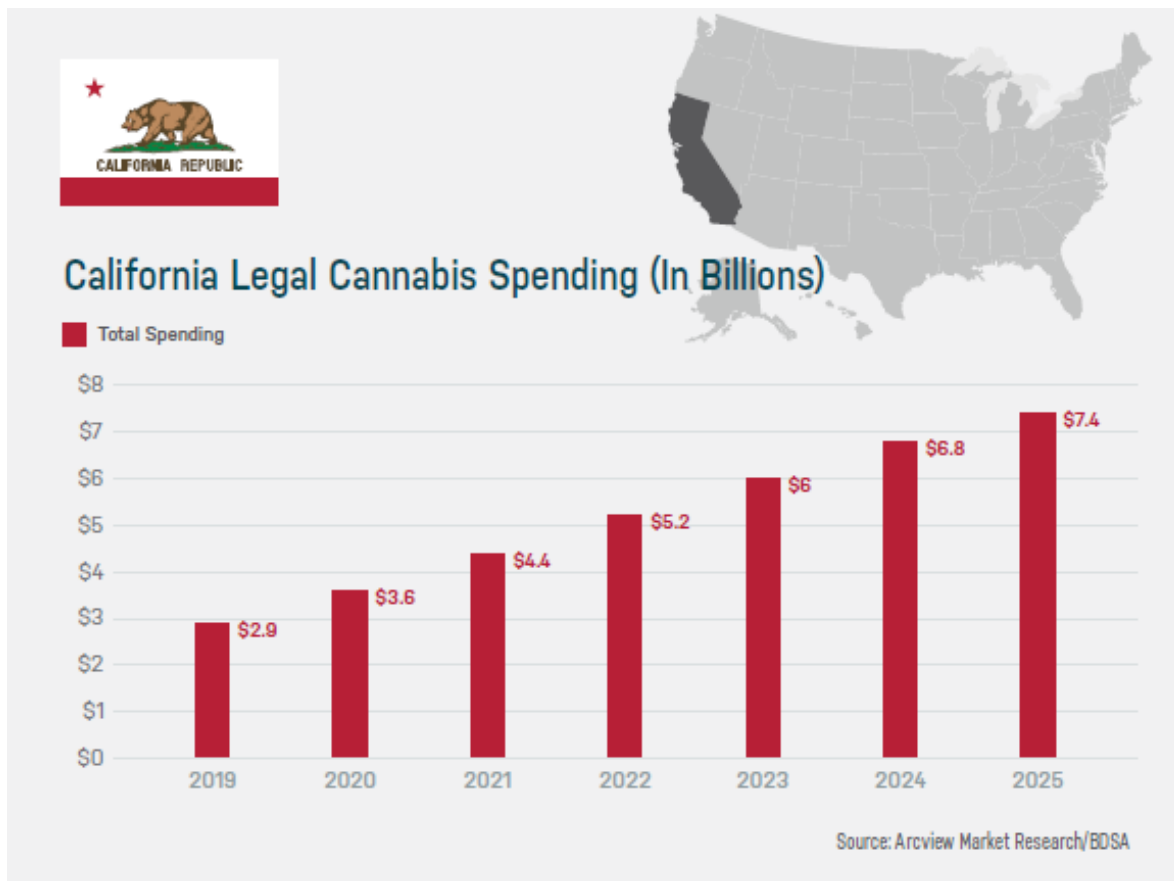

Of course, with certain municipalities prohibiting or restricting the recreational sale of cannabis in their respective counties/cities, the Industry has been able to expand its market base to those consumers via delivery (pending lawsuit against BCC to prohibit cannabis delivery to consumers located in states outlawing recreational marijuana). Delivery has been a crucial element to the Industry since its legalization, and continues to play an increasing role in same (especially since the happening of COVID-19). For instance, *Eaze*, a San Francisco-based platform coordinating cannabis deliveries from retail to consumer has reported a 38% increase in deliveries and 51% in first-time deliveries statewide over a one

week period on March 16, 2020. *Medmen*, with 11 hybrid retail/delivery locations throughout California, also reported an almost 100% increase in delivery orders on or about March 13, 2020.

While there are no established studies done to provide statistics on the percentage of cannabis revenue (retail vs. delivery), from our experience in dealing with cannabis retail operators and Industry clients, we (Cannabis Real Estate Consultants [“CREC”]—a licensed commercial real estate broker specializing in the cannabis Industry) estimate approximately 90% of California-based retailers to utilize delivery as part of their services (in areas where cannabis delivery is allowed), making up for about 35-40% of their daily sales.

In 2016, David Hua, CEO of *Meadow*—software company specializing in cannabis POS systems—stated an estimate of 40-45% of revenues drawn in by California-based (medical marijuana) retailers are derived through delivery. Given the Industry market’s history and trend towards convenience through delivery (and for end consumers in areas where cannabis is prohibited), delivery is here to stay and is only expected to increase in use.

Based off of our discussions with Monterey Retail Solutions (“**Applicant**” or “**Appellee**”) and its traffic study engineer, it is our understanding that Applicant intends on aggressively pursuing this market trend to drive sales through delivery to not only maximize their revenue and sales, but to limit and/or reduce the nominal increase in traffic expected from the retail location’s establishment. This reduction will likely be around the same percentage in which sales are derived through delivery (i.e., 35-40%); by way of example, if the anticipated trips for Applicant’s dispensary is 90 per day, then this number will be reduced by 31.5 trips through the use of delivery.

CREC Compliance

Jared A. Younker

Jared A. Younker

[1] <https://www.latimes.com/lifestyle/story/2020-03-19/coronavirus-cannabis-sale-surge>

[2] <https://mjbizmagazine.com/industry-snapshot-california-marijuana-delivery-services-apps/>

Signature Certificate

Document Ref.: TFZ9X-TDVZJ-YFETN-C4QHV

Document signed by:

	Jared Younker	<i>Jared A. Younker</i>
	Verified E-mail: jared@crec.us	
	IP: 12.222.87.186	Date: 30 Jun 2020 21:31:05 UTC
		

Document completed by all parties on:

30 Jun 2020 21:31:05 UTC

Page 1 of 1



Signed with PandaDoc.com

PandaDoc is the document platform that boosts your company's revenue by accelerating the way it transacts.



Appendix E

Collision Rate

Calculations

Collision Rates:

Southbound US 101 / Prunedale South Road:

Collisions: 9 collisions
Years: 5 years
ADT: 29,580 vehicles/day (estimated per 2020 traffic counts)

Collision Rate: 0.17 collisions per MVM
Statewide Average: 0.16 collisions per MVM (per 2016 Collision Data on California State Highways, Caltrans, 2020)
Larger

Prunedale South Road:

Collisions: 12 collisions
Years: 6 years
ADT: 1,433 vehicles/day (per Monterey County Annual Average Daily Traffic 2019, Monterey County Public Works, 2019)
Length: 0.98 miles

Collision Rate: 3.90 collisions per MVM
Statewide Average: 1.03 collisions per MVM (per 2016 Collision Data on California State Highways, Caltrans, 2020)
Larger

Prunedale South Road / Blackie Road

Collisions: 5 collisions
Years: 6 years
ADT: 6,270 vehicles/day (estimated per 2016 traffic counts from La Tourette Subdivision Traffic Impact Analysis, Keith Higgins Traffic Engineer, October 4, 2017)

Collision Rate: 0.36 collisions per MVM
Statewide Average: 0.43 collisions per MVM (per 2016 Collision Data on California State Highways, Caltrans, 2020)
Smaller

Appendix F

Intersection
Level of Service
Calculations

Existing Conditions
&
Existing Plus Project
Conditions

Intersection						
Int Delay, s/veh	1.4					
Movement	WBL	WBR	NBT	NBR	SBL	SBT
Lane Configurations						
Traffic Vol, veh/h	7	16	94	11	2	36
Future Vol, veh/h	7	16	94	11	2	36
Conflicting Peds, #/hr	0	0	0	0	0	0
Sign Control	Stop	Stop	Free	Free	Free	Free
RT Channelized	-	None	-	None	-	None
Storage Length	0	-	-	-	-	-
Veh in Median Storage, #	0	-	0	-	-	0
Grade, %	0	-	0	-	-	0
Peak Hour Factor	80	80	80	80	80	80
Heavy Vehicles, %	2	2	4	4	2	2
Mvmt Flow	9	20	118	14	3	45

Major/Minor	Minor1	Major1	Major2		
Conflicting Flow All	176	125	0	0	132
Stage 1	125	-	-	-	-
Stage 2	51	-	-	-	-
Critical Hdwy	6.42	6.22	-	-	4.12
Critical Hdwy Stg 1	5.42	-	-	-	-
Critical Hdwy Stg 2	5.42	-	-	-	-
Follow-up Hdwy	3.518	3.318	-	-	2.218
Pot Cap-1 Maneuver	814	926	-	-	1453
Stage 1	901	-	-	-	-
Stage 2	971	-	-	-	-
Platoon blocked, %			-	-	-
Mov Cap-1 Maneuver	812	926	-	-	1453
Mov Cap-2 Maneuver	812	-	-	-	-
Stage 1	899	-	-	-	-
Stage 2	971	-	-	-	-

Approach	WB	NB	SB
HCM Control Delay, s	9.2	0	0.4
HCM LOS	A		

Minor Lane/Major Mvmt	NBT	NBRWBLn1	SBL	SBT
Capacity (veh/h)	-	-	888	1453
HCM Lane V/C Ratio	-	-	0.032	0.002
HCM Control Delay (s)	-	-	9.2	7.5
HCM Lane LOS	-	-	A	A
HCM 95th %tile Q(veh)	-	-	0.1	0

Intersection						
Int Delay, s/veh	0.3					
Movement	EBL	EBR	NBL	NBT	SBT	SBR
Lane Configurations		↗			↘	
Traffic Vol, veh/h	0	7	0	0	188	7
Future Vol, veh/h	0	7	0	0	188	7
Conflicting Peds, #/hr	0	0	0	0	0	0
Sign Control	Stop	Stop	Free	Free	Free	Free
RT Channelized	-	None	-	None	-	None
Storage Length	-	0	-	-	-	-
Veh in Median Storage, #	0	-	-	-	0	-
Grade, %	0	-	-	0	0	-
Peak Hour Factor	89	89	89	89	89	89
Heavy Vehicles, %	2	2	12	12	12	12
Mvmt Flow	0	8	0	0	211	8





















Major/Minor	Minor2		Major2	
Conflicting Flow All	-	215	-	0
Stage 1	-	-	-	-
Stage 2	-	-	-	-
Critical Hdwy	-	6.22	-	-
Critical Hdwy Stg 1	-	-	-	-
Critical Hdwy Stg 2	-	-	-	-
Follow-up Hdwy	-	3.318	-	-
Pot Cap-1 Maneuver	0	825	-	-
Stage 1	0	-	-	-
Stage 2	0	-	-	-
Platoon blocked, %			-	-
Mov Cap-1 Maneuver	-	825	-	-
Mov Cap-2 Maneuver	-	-	-	-
Stage 1	-	-	-	-
Stage 2	-	-	-	-

Approach	EB	SB
HCM Control Delay, s	9.4	0
HCM LOS	A	

Minor Lane/Major Mvmt	EBLn1	SBT	SBR
Capacity (veh/h)	825	-	-
HCM Lane V/C Ratio	0.01	-	-
HCM Control Delay (s)	9.4	-	-
HCM Lane LOS	A	-	-
HCM 95th %tile Q(veh)	0	-	-

HCM 2010 Signalized Intersection Summary
3: Prunedale South Rd & Blackie Rd

Existing AM

												
Movement	EBL	EBT	EBR	WBL	WBT	WBR	NBL	NBT	NBR	SBL	SBT	SBR
Lane Configurations												
Traffic Volume (veh/h)	19	53	56	206	40	5	77	9	158	10	21	12
Future Volume (veh/h)	19	53	56	206	40	5	77	9	158	10	21	12
Number	7	4	14	3	8	18	5	2	12	1	6	16
Initial Q (Qb), veh	0	0	0	0	0	0	0	0	0	0	0	0
Ped-Bike Adj(A_pbT)	1.00		1.00	1.00		1.00	1.00		1.00	1.00		1.00
Parking Bus, Adj	1.00	1.00	1.00	1.00	1.00	1.00	1.00	1.00	1.00	1.00	1.00	1.00
Adj Sat Flow, veh/h/ln	1759	1759	1759	1863	1863	1900	1827	1827	1900	1900	1863	1900
Adj Flow Rate, veh/h	23	63	67	245	48	6	92	11	188	12	25	14
Adj No. of Lanes	1	1	1	1	1	0	1	1	0	0	1	0
Peak Hour Factor	0.84	0.84	0.84	0.84	0.84	0.84	0.84	0.84	0.84	0.84	0.84	0.84
Percent Heavy Veh, %	8	8	8	2	2	2	4	4	4	2	2	2
Cap, veh/h	47	185	157	307	407	51	723	36	610	204	388	186
Arrive On Green	0.03	0.11	0.11	0.17	0.25	0.25	0.41	0.41	0.41	0.41	0.41	0.41
Sat Flow, veh/h	1675	1759	1495	1774	1624	203	1337	87	1479	248	941	450
Grp Volume(v), veh/h	23	63	67	245	0	54	92	0	199	51	0	0
Grp Sat Flow(s),veh/h/ln	1675	1759	1495	1774	0	1827	1337	0	1566	1639	0	0
Q Serve(g_s), s	0.6	1.5	1.8	5.8	0.0	1.0	0.9	0.0	3.7	0.0	0.0	0.0
Cycle Q Clear(g_c), s	0.6	1.5	1.8	5.8	0.0	1.0	1.7	0.0	3.7	0.8	0.0	0.0
Prop In Lane	1.00		1.00	1.00		0.11	1.00		0.94	0.24		0.27
Lane Grp Cap(c), veh/h	47	185	157	307	0	458	723	0	646	778	0	0
V/C Ratio(X)	0.49	0.34	0.43	0.80	0.00	0.12	0.13	0.00	0.31	0.07	0.00	0.00
Avail Cap(c_a), veh/h	192	725	616	427	0	983	723	0	646	778	0	0
HCM Platoon Ratio	1.00	1.00	1.00	1.00	1.00	1.00	1.00	1.00	1.00	1.00	1.00	1.00
Upstream Filter(I)	1.00	1.00	1.00	1.00	0.00	1.00	1.00	0.00	1.00	1.00	0.00	0.00
Uniform Delay (d), s/veh	20.9	18.1	18.3	17.3	0.0	12.6	8.0	0.0	8.6	7.8	0.0	0.0
Incr Delay (d2), s/veh	7.8	1.1	1.8	7.1	0.0	0.1	0.4	0.0	1.2	0.2	0.0	0.0
Initial Q Delay(d3),s/veh	0.0	0.0	0.0	0.0	0.0	0.0	0.0	0.0	0.0	0.0	0.0	0.0
%ile BackOfQ(50%),veh/ln	0.4	0.8	0.8	3.4	0.0	0.5	0.8	0.0	1.8	0.4	0.0	0.0
LnGrp Delay(d),s/veh	28.7	19.2	20.1	24.4	0.0	12.7	8.4	0.0	9.9	7.9	0.0	0.0
LnGrp LOS	C	B	C	C		B	A		A	A		
Approach Vol, veh/h		153			299			291				51
Approach Delay, s/veh		21.0			22.3			9.4				7.9
Approach LOS		C			C			A				A
Timer	1	2	3	4	5	6	7	8				
Assigned Phs		2	3	4		6	7	8				
Phs Duration (G+Y+Rc), s		22.5	12.1	9.1		22.5	5.7	15.4				
Change Period (Y+Rc), s		4.5	4.5	4.5		4.5	4.5	4.5				
Max Green Setting (Gmax), s		18.0	10.5	18.0		18.0	5.0	23.5				
Max Q Clear Time (g_c+I1), s		5.7	7.8	3.8		2.8	2.6	3.0				
Green Ext Time (p_c), s		1.2	0.2	0.4		0.1	0.0	0.2				
Intersection Summary												
HCM 2010 Ctrl Delay			16.4									
HCM 2010 LOS			B									

Intersection						
Int Delay, s/veh	1					
Movement	WBL	WBR	NBT	NBR	SBL	SBT
Lane Configurations						
Traffic Vol, veh/h	9	13	148	13	11	130
Future Vol, veh/h	9	13	148	13	11	130
Conflicting Peds, #/hr	0	0	0	0	0	0
Sign Control	Stop	Stop	Free	Free	Free	Free
RT Channelized	-	None	-	None	-	None
Storage Length	0	-	-	-	-	-
Veh in Median Storage, #	0	-	0	-	-	0
Grade, %	0	-	0	-	-	0
Peak Hour Factor	76	76	76	76	76	76
Heavy Vehicles, %	2	2	2	2	2	2
Mvmt Flow	12	17	195	17	14	171

Major/Minor	Minor1	Major1	Major2		
Conflicting Flow All	403	204	0	0	212
Stage 1	204	-	-	-	-
Stage 2	199	-	-	-	-
Critical Hdwy	6.42	6.22	-	-	4.12
Critical Hdwy Stg 1	5.42	-	-	-	-
Critical Hdwy Stg 2	5.42	-	-	-	-
Follow-up Hdwy	3.518	3.318	-	-	2.218
Pot Cap-1 Maneuver	603	837	-	-	1358
Stage 1	830	-	-	-	-
Stage 2	835	-	-	-	-
Platoon blocked, %			-	-	-
Mov Cap-1 Maneuver	596	837	-	-	1358
Mov Cap-2 Maneuver	596	-	-	-	-
Stage 1	821	-	-	-	-
Stage 2	835	-	-	-	-

Approach	WB	NB	SB
HCM Control Delay, s	10.2	0	0.6
HCM LOS	B		

Minor Lane/Major Mvmt	NBT	NBRWBLn1	SBL	SBT
Capacity (veh/h)	-	-	718	1358
HCM Lane V/C Ratio	-	-	0.04	0.011
HCM Control Delay (s)	-	-	10.2	7.7
HCM Lane LOS	-	-	B	A
HCM 95th %tile Q(veh)	-	-	0.1	0

Intersection						
Int Delay, s/veh	0.7					
Movement	EBL	EBR	NBL	NBT	SBT	SBR
Lane Configurations		↗			↘	
Traffic Vol, veh/h	0	22	0	0	251	38
Future Vol, veh/h	0	22	0	0	251	38
Conflicting Peds, #/hr	0	0	0	0	0	0
Sign Control	Stop	Stop	Free	Free	Free	Free
RT Channelized	-	None	-	None	-	None
Storage Length	-	0	-	-	-	-
Veh in Median Storage, #	0	-	-	-	0	-
Grade, %	0	-	-	0	0	-
Peak Hour Factor	94	94	94	94	94	94
Heavy Vehicles, %	2	2	7	7	7	7
Mvmt Flow	0	23	0	0	267	40





















Major/Minor	Minor2		Major2	
Conflicting Flow All	-	287	-	0
Stage 1	-	-	-	-
Stage 2	-	-	-	-
Critical Hdwy	-	6.22	-	-
Critical Hdwy Stg 1	-	-	-	-
Critical Hdwy Stg 2	-	-	-	-
Follow-up Hdwy	-	3.318	-	-
Pot Cap-1 Maneuver	0	752	-	-
Stage 1	0	-	-	-
Stage 2	0	-	-	-
Platoon blocked, %			-	-
Mov Cap-1 Maneuver	-	752	-	-
Mov Cap-2 Maneuver	-	-	-	-
Stage 1	-	-	-	-
Stage 2	-	-	-	-

Approach	EB	SB
HCM Control Delay, s	9.9	0
HCM LOS	A	

Minor Lane/Major Mvmt	EBLn1	SBT	SBR
Capacity (veh/h)	752	-	-
HCM Lane V/C Ratio	0.031	-	-
HCM Control Delay (s)	9.9	-	-
HCM Lane LOS	A	-	-
HCM 95th %tile Q(veh)	0.1	-	-

HCM 2010 Signalized Intersection Summary
3: Prunedale South Rd & Blackie Rd

Existing PM

												
Movement	EBL	EBT	EBR	WBL	WBT	WBR	NBL	NBT	NBR	SBL	SBT	SBR
Lane Configurations												
Traffic Volume (veh/h)	50	126	74	157	31	16	60	21	51	9	27	9
Future Volume (veh/h)	50	126	74	157	31	16	60	21	51	9	27	9
Number	7	4	14	3	8	18	5	2	12	1	6	16
Initial Q (Qb), veh	0	0	0	0	0	0	0	0	0	0	0	0
Ped-Bike Adj(A_pbT)	1.00		1.00	1.00		1.00	1.00		1.00	1.00		1.00
Parking Bus, Adj	1.00	1.00	1.00	1.00	1.00	1.00	1.00	1.00	1.00	1.00	1.00	1.00
Adj Sat Flow, veh/h/ln	1845	1845	1845	1863	1863	1900	1845	1845	1900	1900	1863	1900
Adj Flow Rate, veh/h	56	142	83	176	35	18	67	24	57	10	30	10
Adj No. of Lanes	1	1	1	1	1	0	1	1	0	0	1	0
Peak Hour Factor	0.89	0.89	0.89	0.89	0.89	0.89	0.89	0.89	0.89	0.89	0.89	0.89
Percent Heavy Veh, %	3	3	3	2	2	2	3	3	3	2	2	2
Cap, veh/h	100	249	211	228	240	123	743	205	486	187	492	144
Arrive On Green	0.06	0.13	0.13	0.13	0.21	0.21	0.42	0.42	0.42	0.42	0.42	0.42
Sat Flow, veh/h	1757	1845	1568	1774	1161	597	1348	486	1155	205	1168	343
Grp Volume(v), veh/h	56	142	83	176	0	53	67	0	81	50	0	0
Grp Sat Flow(s),veh/h/ln	1757	1845	1568	1774	0	1757	1348	0	1641	1716	0	0
Q Serve(g_s), s	1.3	3.1	2.1	4.1	0.0	1.1	0.4	0.0	1.3	0.0	0.0	0.0
Cycle Q Clear(g_c), s	1.3	3.1	2.1	4.1	0.0	1.1	1.1	0.0	1.3	0.7	0.0	0.0
Prop In Lane	1.00		1.00	1.00		0.34	1.00		0.70	0.20		0.20
Lane Grp Cap(c), veh/h	100	249	211	228	0	363	743	0	690	823	0	0
V/C Ratio(X)	0.56	0.57	0.39	0.77	0.00	0.15	0.09	0.00	0.12	0.06	0.00	0.00
Avail Cap(c_a), veh/h	255	776	660	435	0	916	743	0	690	823	0	0
HCM Platoon Ratio	1.00	1.00	1.00	1.00	1.00	1.00	1.00	1.00	1.00	1.00	1.00	1.00
Upstream Filter(I)	1.00	1.00	1.00	1.00	0.00	1.00	1.00	0.00	1.00	1.00	0.00	0.00
Uniform Delay (d), s/veh	19.7	17.3	16.9	18.0	0.0	13.9	7.5	0.0	7.5	7.4	0.0	0.0
Incr Delay (d2), s/veh	4.9	2.1	1.2	5.4	0.0	0.2	0.2	0.0	0.3	0.1	0.0	0.0
Initial Q Delay(d3),s/veh	0.0	0.0	0.0	0.0	0.0	0.0	0.0	0.0	0.0	0.0	0.0	0.0
%ile BackOfQ(50%),veh/ln	0.8	1.7	1.0	2.3	0.0	0.5	0.5	0.0	0.7	0.4	0.0	0.0
LnGrp Delay(d),s/veh	24.5	19.4	18.1	23.5	0.0	14.1	7.7	0.0	7.9	7.5	0.0	0.0
LnGrp LOS	C	B	B	C		B	A		A	A		
Approach Vol, veh/h		281			229			148			50	
Approach Delay, s/veh		20.0			21.3			7.8			7.5	
Approach LOS		C			C			A			A	
Timer	1	2	3	4	5	6	7	8				
Assigned Phs		2	3	4		6	7	8				
Phs Duration (G+Y+Rc), s		22.5	10.0	10.3		22.5	6.9	13.3				
Change Period (Y+Rc), s		4.5	4.5	4.5		4.5	4.5	4.5				
Max Green Setting (Gmax), s		18.0	10.5	18.0		18.0	6.2	22.3				
Max Q Clear Time (g_c+I1), s		3.3	6.1	5.1		2.7	3.3	3.1				
Green Ext Time (p_c), s		0.5	0.2	0.8		0.1	0.0	0.2				
Intersection Summary												
HCM 2010 Ctrl Delay			17.0									
HCM 2010 LOS			B									

Intersection						
Int Delay, s/veh	1.4					
Movement	WBL	WBR	NBT	NBR	SBL	SBT
Lane Configurations	W		T			T
Traffic Vol, veh/h	8	16	94	12	3	36
Future Vol, veh/h	8	16	94	12	3	36
Conflicting Peds, #/hr	0	0	0	0	0	0
Sign Control	Stop	Stop	Free	Free	Free	Free
RT Channelized	-	None	-	None	-	None
Storage Length	0	-	-	-	-	-
Veh in Median Storage, #	0	-	0	-	-	0
Grade, %	0	-	0	-	-	0
Peak Hour Factor	80	80	80	80	80	80
Heavy Vehicles, %	2	2	4	4	2	2
Mvmt Flow	10	20	118	15	4	45

Major/Minor	Minor1	Major1	Major2		
Conflicting Flow All	179	126	0	0	133
Stage 1	126	-	-	-	-
Stage 2	53	-	-	-	-
Critical Hdwy	6.42	6.22	-	-	4.12
Critical Hdwy Stg 1	5.42	-	-	-	-
Critical Hdwy Stg 2	5.42	-	-	-	-
Follow-up Hdwy	3.518	3.318	-	-	2.218
Pot Cap-1 Maneuver	811	924	-	-	1452
Stage 1	900	-	-	-	-
Stage 2	970	-	-	-	-
Platoon blocked, %			-	-	-
Mov Cap-1 Maneuver	809	924	-	-	1452
Mov Cap-2 Maneuver	809	-	-	-	-
Stage 1	897	-	-	-	-
Stage 2	970	-	-	-	-

Approach	WB	NB	SB
HCM Control Delay, s	9.2	0	0.6
HCM LOS	A		

Minor Lane/Major Mvmt	NBT	NBRWBLn1	SBL	SBT
Capacity (veh/h)	-	-	882	1452
HCM Lane V/C Ratio	-	-	0.034	0.003
HCM Control Delay (s)	-	-	9.2	7.5
HCM Lane LOS	-	-	A	A
HCM 95th %tile Q(veh)	-	-	0.1	0

Intersection						
Int Delay, s/veh	0.4					
Movement	EBL	EBR	NBL	NBT	SBT	SBR
Lane Configurations		↗			↘	
Traffic Vol, veh/h	0	8	0	0	188	8
Future Vol, veh/h	0	8	0	0	188	8
Conflicting Peds, #/hr	0	0	0	0	0	0
Sign Control	Stop	Stop	Free	Free	Free	Free
RT Channelized	-	None	-	None	-	None
Storage Length	-	0	-	-	-	-
Veh in Median Storage, #	0	-	-	-	0	-
Grade, %	0	-	-	0	0	-
Peak Hour Factor	89	89	89	89	89	89
Heavy Vehicles, %	2	2	12	12	12	12
Mvmt Flow	0	9	0	0	211	9





















Major/Minor	Minor2		Major2	
Conflicting Flow All	-	216	-	0
Stage 1	-	-	-	-
Stage 2	-	-	-	-
Critical Hdwy	-	6.22	-	-
Critical Hdwy Stg 1	-	-	-	-
Critical Hdwy Stg 2	-	-	-	-
Follow-up Hdwy	-	3.318	-	-
Pot Cap-1 Maneuver	0	824	-	-
Stage 1	0	-	-	-
Stage 2	0	-	-	-
Platoon blocked, %			-	-
Mov Cap-1 Maneuver	-	824	-	-
Mov Cap-2 Maneuver	-	-	-	-
Stage 1	-	-	-	-
Stage 2	-	-	-	-

Approach	EB	SB
HCM Control Delay, s	9.4	0
HCM LOS	A	

Minor Lane/Major Mvmt	EBLn1	SBT	SBR
Capacity (veh/h)	824	-	-
HCM Lane V/C Ratio	0.011	-	-
HCM Control Delay (s)	9.4	-	-
HCM Lane LOS	A	-	-
HCM 95th %tile Q(veh)	0	-	-

HCM 2010 Signalized Intersection Summary
3: Prunedale South Rd & Blackie Rd

Existing Plus Project AM

												
Movement	EBL	EBT	EBR	WBL	WBT	WBR	NBL	NBT	NBR	SBL	SBT	SBR
Lane Configurations												
Traffic Volume (veh/h)	19	53	56	206	40	5	77	10	158	10	22	12
Future Volume (veh/h)	19	53	56	206	40	5	77	10	158	10	22	12
Number	7	4	14	3	8	18	5	2	12	1	6	16
Initial Q (Qb), veh	0	0	0	0	0	0	0	0	0	0	0	0
Ped-Bike Adj(A_pbT)	1.00		1.00	1.00		1.00	1.00		1.00	1.00		1.00
Parking Bus, Adj	1.00	1.00	1.00	1.00	1.00	1.00	1.00	1.00	1.00	1.00	1.00	1.00
Adj Sat Flow, veh/h/ln	1759	1759	1759	1863	1863	1900	1827	1827	1900	1900	1863	1900
Adj Flow Rate, veh/h	23	63	67	245	48	6	92	12	188	12	26	14
Adj No. of Lanes	1	1	1	1	1	0	1	1	0	0	1	0
Peak Hour Factor	0.84	0.84	0.84	0.84	0.84	0.84	0.84	0.84	0.84	0.84	0.84	0.84
Percent Heavy Veh, %	8	8	8	2	2	2	4	4	4	2	2	2
Cap, veh/h	47	185	157	307	407	51	723	39	607	201	396	182
Arrive On Green	0.03	0.11	0.11	0.17	0.25	0.25	0.41	0.41	0.41	0.41	0.41	0.41
Sat Flow, veh/h	1675	1759	1495	1774	1624	203	1335	94	1473	242	960	443
Grp Volume(v), veh/h	23	63	67	245	0	54	92	0	200	52	0	0
Grp Sat Flow(s),veh/h/ln	1675	1759	1495	1774	0	1827	1335	0	1567	1644	0	0
Q Serve(g_s), s	0.6	1.5	1.8	5.8	0.0	1.0	0.9	0.0	3.8	0.0	0.0	0.0
Cycle Q Clear(g_c), s	0.6	1.5	1.8	5.8	0.0	1.0	1.6	0.0	3.8	0.8	0.0	0.0
Prop In Lane	1.00		1.00	1.00		0.11	1.00		0.94	0.23		0.27
Lane Grp Cap(c), veh/h	47	185	157	307	0	458	723	0	646	779	0	0
V/C Ratio(X)	0.49	0.34	0.43	0.80	0.00	0.12	0.13	0.00	0.31	0.07	0.00	0.00
Avail Cap(c_a), veh/h	192	725	616	427	0	983	723	0	646	779	0	0
HCM Platoon Ratio	1.00	1.00	1.00	1.00	1.00	1.00	1.00	1.00	1.00	1.00	1.00	1.00
Upstream Filter(I)	1.00	1.00	1.00	1.00	0.00	1.00	1.00	0.00	1.00	1.00	0.00	0.00
Uniform Delay (d), s/veh	20.9	18.1	18.3	17.3	0.0	12.6	8.0	0.0	8.6	7.8	0.0	0.0
Incr Delay (d2), s/veh	7.8	1.1	1.8	7.1	0.0	0.1	0.4	0.0	1.2	0.2	0.0	0.0
Initial Q Delay(d3),s/veh	0.0	0.0	0.0	0.0	0.0	0.0	0.0	0.0	0.0	0.0	0.0	0.0
%ile BackOfQ(50%),veh/ln	0.4	0.8	0.8	3.4	0.0	0.5	0.8	0.0	1.8	0.4	0.0	0.0
LnGrp Delay(d),s/veh	28.7	19.2	20.1	24.4	0.0	12.7	8.4	0.0	9.9	7.9	0.0	0.0
LnGrp LOS	C	B	C	C		B	A		A	A		
Approach Vol, veh/h		153			299			292			52	
Approach Delay, s/veh		21.0			22.3			9.4			7.9	
Approach LOS		C			C			A			A	
Timer	1	2	3	4	5	6	7	8				
Assigned Phs		2	3	4		6	7	8				
Phs Duration (G+Y+Rc), s		22.5	12.1	9.1		22.5	5.7	15.4				
Change Period (Y+Rc), s		4.5	4.5	4.5		4.5	4.5	4.5				
Max Green Setting (Gmax), s		18.0	10.5	18.0		18.0	5.0	23.5				
Max Q Clear Time (g_c+I1), s		5.8	7.8	3.8		2.8	2.6	3.0				
Green Ext Time (p_c), s		1.2	0.2	0.4		0.2	0.0	0.2				
Intersection Summary												
HCM 2010 Ctrl Delay			16.4									
HCM 2010 LOS			B									

Intersection						
Int Delay, s/veh	1.2					
Movement	WBL	WBR	NBT	NBR	SBL	SBT
Lane Configurations	W	W	T	T	T	T
Traffic Vol, veh/h	13	15	148	15	13	130
Future Vol, veh/h	13	15	148	15	13	130
Conflicting Peds, #/hr	0	0	0	0	0	0
Sign Control	Stop	Stop	Free	Free	Free	Free
RT Channelized	-	None	-	None	-	None
Storage Length	0	-	-	-	-	-
Veh in Median Storage, #	0	-	0	-	-	0
Grade, %	0	-	0	-	-	0
Peak Hour Factor	76	76	76	76	76	76
Heavy Vehicles, %	2	2	2	2	2	2
Mvmt Flow	17	20	195	20	17	171

Major/Minor	Minor1	Major1	Major2			
Conflicting Flow All	410	205	0	0	215	0
Stage 1	205	-	-	-	-	-
Stage 2	205	-	-	-	-	-
Critical Hdwy	6.42	6.22	-	-	4.12	-
Critical Hdwy Stg 1	5.42	-	-	-	-	-
Critical Hdwy Stg 2	5.42	-	-	-	-	-
Follow-up Hdwy	3.518	3.318	-	-	2.218	-
Pot Cap-1 Maneuver	598	836	-	-	1355	-
Stage 1	829	-	-	-	-	-
Stage 2	829	-	-	-	-	-
Platoon blocked, %			-	-		-
Mov Cap-1 Maneuver	590	836	-	-	1355	-
Mov Cap-2 Maneuver	590	-	-	-	-	-
Stage 1	817	-	-	-	-	-
Stage 2	829	-	-	-	-	-

Approach	WB	NB	SB
HCM Control Delay, s	10.4	0	0.7
HCM LOS	B		

Minor Lane/Major Mvmt	NBT	NBRWBLn1	SBL	SBT
Capacity (veh/h)	-	-	700	1355
HCM Lane V/C Ratio	-	-	0.053	0.013
HCM Control Delay (s)	-	-	10.4	7.7
HCM Lane LOS	-	-	B	A
HCM 95th %tile Q(veh)	-	-	0.2	0

Intersection						
Int Delay, s/veh	0.8					
Movement	EBL	EBR	NBL	NBT	SBT	SBR
Lane Configurations		↗			↘	
Traffic Vol, veh/h	0	24	0	0	251	42
Future Vol, veh/h	0	24	0	0	251	42
Conflicting Peds, #/hr	0	0	0	0	0	0
Sign Control	Stop	Stop	Free	Free	Free	Free
RT Channelized	-	None	-	None	-	None
Storage Length	-	0	-	-	-	-
Veh in Median Storage, #	0	-	-	-	0	-
Grade, %	0	-	-	0	0	-
Peak Hour Factor	94	94	94	94	94	94
Heavy Vehicles, %	2	2	7	7	7	7
Mvmt Flow	0	26	0	0	267	45





















Major/Minor	Minor2		Major2	
Conflicting Flow All	-	290	-	0
Stage 1	-	-	-	-
Stage 2	-	-	-	-
Critical Hdwy	-	6.22	-	-
Critical Hdwy Stg 1	-	-	-	-
Critical Hdwy Stg 2	-	-	-	-
Follow-up Hdwy	-	3.318	-	-
Pot Cap-1 Maneuver	0	749	-	-
Stage 1	0	-	-	-
Stage 2	0	-	-	-
Platoon blocked, %			-	-
Mov Cap-1 Maneuver	-	749	-	-
Mov Cap-2 Maneuver	-	-	-	-
Stage 1	-	-	-	-
Stage 2	-	-	-	-

Approach	EB	SB
HCM Control Delay, s	10	0
HCM LOS	B	

Minor Lane/Major Mvmt	EBLn1	SBT	SBR
Capacity (veh/h)	749	-	-
HCM Lane V/C Ratio	0.034	-	-
HCM Control Delay (s)	10	-	-
HCM Lane LOS	B	-	-
HCM 95th %tile Q(veh)	0.1	-	-

HCM 2010 Signalized Intersection Summary
3: Prunedale South Rd & Blackie Rd

Existing Plus Project PM

												
Movement	EBL	EBT	EBR	WBL	WBT	WBR	NBL	NBT	NBR	SBL	SBT	SBR
Lane Configurations												
Traffic Volume (veh/h)	50	126	74	157	31	16	60	23	51	9	27	9
Future Volume (veh/h)	50	126	74	157	31	16	60	23	51	9	27	9
Number	7	4	14	3	8	18	5	2	12	1	6	16
Initial Q (Qb), veh	0	0	0	0	0	0	0	0	0	0	0	0
Ped-Bike Adj(A_pbT)	1.00		1.00	1.00		1.00	1.00		1.00	1.00		1.00
Parking Bus, Adj	1.00	1.00	1.00	1.00	1.00	1.00	1.00	1.00	1.00	1.00	1.00	1.00
Adj Sat Flow, veh/h/ln	1845	1845	1845	1863	1863	1900	1845	1845	1900	1900	1863	1900
Adj Flow Rate, veh/h	56	142	83	176	35	18	67	26	57	10	30	10
Adj No. of Lanes	1	1	1	1	1	0	1	1	0	0	1	0
Peak Hour Factor	0.89	0.89	0.89	0.89	0.89	0.89	0.89	0.89	0.89	0.89	0.89	0.89
Percent Heavy Veh, %	3	3	3	2	2	2	3	3	3	2	2	2
Cap, veh/h	100	249	211	228	240	123	743	217	475	187	491	144
Arrive On Green	0.06	0.13	0.13	0.13	0.21	0.21	0.42	0.42	0.42	0.42	0.42	0.42
Sat Flow, veh/h	1757	1845	1568	1774	1161	597	1348	515	1130	205	1168	343
Grp Volume(v), veh/h	56	142	83	176	0	53	67	0	83	50	0	0
Grp Sat Flow(s),veh/h/ln	1757	1845	1568	1774	0	1757	1348	0	1645	1716	0	0
Q Serve(g_s), s	1.3	3.1	2.1	4.1	0.0	1.1	0.4	0.0	1.3	0.0	0.0	0.0
Cycle Q Clear(g_c), s	1.3	3.1	2.1	4.1	0.0	1.1	1.1	0.0	1.3	0.7	0.0	0.0
Prop In Lane	1.00		1.00	1.00		0.34	1.00		0.69	0.20		0.20
Lane Grp Cap(c), veh/h	100	249	211	228	0	363	743	0	692	823	0	0
V/C Ratio(X)	0.56	0.57	0.39	0.77	0.00	0.15	0.09	0.00	0.12	0.06	0.00	0.00
Avail Cap(c_a), veh/h	255	776	660	435	0	916	743	0	692	823	0	0
HCM Platoon Ratio	1.00	1.00	1.00	1.00	1.00	1.00	1.00	1.00	1.00	1.00	1.00	1.00
Upstream Filter(I)	1.00	1.00	1.00	1.00	0.00	1.00	1.00	0.00	1.00	1.00	0.00	0.00
Uniform Delay (d), s/veh	19.7	17.3	16.9	18.0	0.0	13.9	7.5	0.0	7.6	7.4	0.0	0.0
Incr Delay (d2), s/veh	4.9	2.1	1.2	5.4	0.0	0.2	0.2	0.0	0.4	0.1	0.0	0.0
Initial Q Delay(d3),s/veh	0.0	0.0	0.0	0.0	0.0	0.0	0.0	0.0	0.0	0.0	0.0	0.0
%ile BackOfQ(50%),veh/ln	0.8	1.7	1.0	2.3	0.0	0.5	0.5	0.0	0.7	0.4	0.0	0.0
LnGrp Delay(d),s/veh	24.5	19.4	18.1	23.5	0.0	14.1	7.7	0.0	7.9	7.5	0.0	0.0
LnGrp LOS	C	B	B	C		B	A		A	A		
Approach Vol, veh/h		281			229			150			50	
Approach Delay, s/veh		20.0			21.3			7.8			7.5	
Approach LOS		C			C			A			A	
Timer	1	2	3	4	5	6	7	8				
Assigned Phs		2	3	4		6	7	8				
Phs Duration (G+Y+Rc), s		22.5	10.0	10.3		22.5	6.9	13.3				
Change Period (Y+Rc), s		4.5	4.5	4.5		4.5	4.5	4.5				
Max Green Setting (Gmax), s		18.0	10.5	18.0		18.0	6.2	22.3				
Max Q Clear Time (g_c+I1), s		3.3	6.1	5.1		2.7	3.3	3.1				
Green Ext Time (p_c), s		0.5	0.2	0.8		0.1	0.0	0.2				
Intersection Summary												
HCM 2010 Ctrl Delay			17.0									
HCM 2010 LOS			B									

Appendix G

Warrant

Worksheet

Intersection 1
 Prunedale South Road - Prunedale North Road / Prunedale South Road
 Southbound Approach

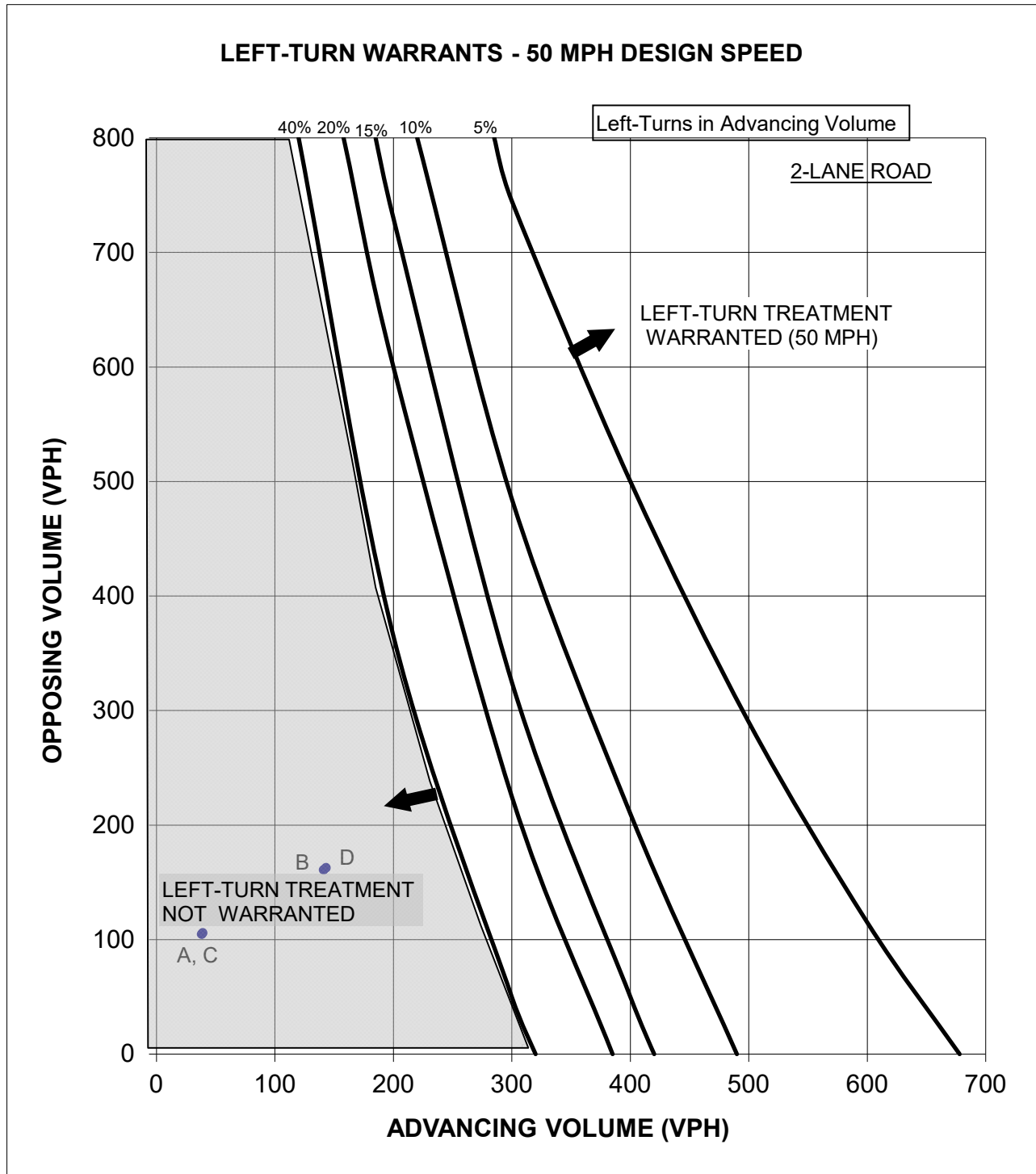

Scenario	Advancing	Opposing	% Left-Turn
A. Existing AM	38	105	5%
B. Existing PM	141	161	8%
C. Ex+Pro AM	39	106	8%
D. Ex+Pro PM	143	163	9%

Source: Transportation Research Board,
 "Intersection Channelization Guide",
 NCHRP Report 279, November, 1985

Keith Higgins
 Traffic Engineer