

Exhibit A

This page intentionally left blank.

**EXHIBIT A
DRAFT RESOLUTION**

**Before the Planning Commission in and for the
County of Monterey, State of California**

In the matter of the application of:

**CUERVO HOLDINGS LP (AT&T MOBILITY)
(PLN180361)**

RESOLUTION NO. ----

Resolution by the Monterey County Zoning

Administrator:

- 1) Finding the project categorically exempt per section 15303 of the California Environmentally Quality Act; and
- 2) Approving a Use Permit to allow the development of a wireless telecommunications facility including a 50-foot-high communications monopole with 8 antennas, and a supporting equipment shelter
- 3) Use Permit to allow ridgeline development.

[PLN180361, Cuervo Holdings, Pine Canyon Rd, King City, Central Salinas Valley Area Plan (APN: 420-071-067-000)]

The Cuervo application (PLN180361) came on for public hearing before the Monterey County Planning Commission on July 10, 2019. Having considered all the written and documentary evidence, the administrative record, the staff report, oral testimony, and other evidence presented, the Planning Commission finds and decides as follows:

FINDINGS

1. **FINDING:** **CONSISTENCY** – The Project, as conditioned, is consistent with the applicable plans and policies which designate this area as appropriate for development.
EVIDENCE: a) During the course of review of this application, the project has been reviewed for consistency with the text, policies, and regulations in:
 - the 2010 Monterey County General Plan;
 - Central Salinas Valley Area Plan
 - Monterey County Zoning Ordinance (Title 21);No conflicts were found to exist. No communications were received during the course of review of the project indicating any inconsistencies with the text, policies, and regulations in these documents.
b) The property is located .75 miles from Pine Canyon Road (Assessor’s Parcel Number 420-071-067-000), Central Salinas Valley Area Plan. The parcel has split zoning of Permanent Grazing /40 acres per unit, Rural Grazing/20 acres per unit, and Low Density Residential / 5 acres per unit. The proposed site is within the Permanent Grazing/ 40 acres

per unit (PG/40) zoning category, which allows wireless communication facilities with a Use Permit pursuant to Section 21.64.310. Therefore, the project is an allowed land use for this site.

- c) The project has been sited and designed to meet the requirements for wireless communications facilities specified in Section 21.64.310 (see Finding 7).
- d) The project will include 8 antennas, fourteen remote radio units, three surge suppression systems, and one microwave dish antenna on one 50-foot tall steel self-support tower antenna structure. One walk in cabinet shelter, one GPS antenna, and one diesel generator will also be constructed within the 40 by 40 foot lease area.
- e) Pursuant to Section 21.66.010 Ridgeline Development, the project will not create a substantially adverse visual impact when viewed from a common public viewing area. (See Finding 7.)
- f) The project planner conducted a site inspection on November 2, 2018 to verify that the project on the subject parcel conforms to the plans listed above.
- g) The project was not referred a Land Use Advisory Committee (LUAC) for review, as one does not exist for the Central Salinas Area Plan area.
- h) The application, project plans, and related support materials submitted by the project applicant to Monterey County RMA-Planning for the proposed development found in Project File PLN180361.

2. **FINDING:** **SITE SUITABILITY** – The site is physically suitable for the use proposed.

- EVIDENCE:**
- a) The project has been reviewed for site suitability by the following departments and agencies: RMA- Planning, South County Fire Protection District, RMA-Public Works, RMA-Environmental Services, and the Environmental Health Bureau. There has been no indication from these departments/agencies that the site is not suitable for the proposed development. Conditions recommended have been incorporated.
 - b) The following reports have been prepared:
 - “Phase I Cultural Assessment AT&T Mobility, LLC Facility Candidate ‘CCL04830’, King City, Monterey County, California” prepared by Helix Environmental Planning, Irvine, CA December 5, 2018.
 - “Electromagnetic Energy (EME) Exposure Report” prepared by OSC Engineering, Pleasanton, CA, August 20, 2018

The above-mentioned technical reports by outside consultants indicated that there are no physical or environmental constraints that would indicate that the site is not suitable for the use proposed. County staff has independently reviewed these reports and concurs with their conclusions.

- c) Staff conducted a site inspection on November 2, 2018 to verify that the site is suitable for this use.
- d) The application, project plans, and related support materials submitted by the project applicant to the Monterey County RMA - Planning for the proposed development found in Project File PLN180361.

3. **FINDING:** **HEALTH AND SAFETY** - The establishment, maintenance, or operation of the project applied for will not under the circumstances of this particular case be detrimental to the health, safety, peace, morals, comfort, and general welfare of persons residing or working in the neighborhood of such proposed use, or be detrimental or injurious to property and improvements in the neighborhood or to the general welfare of the County.
- EVIDENCE:**
- a) The project was reviewed by RMA - Planning, South County Fire Protection District, RMA - Public Works, RMA-Environmental Services, and the Environmental Health Bureau. The respective agencies have recommended conditions, where appropriate, to ensure that the project will not have an adverse effect on the health, safety, and welfare of persons either residing or working in the neighborhood.
 - b) Necessary public facilities are available. The project will not require water or wastewater services and no additional facilities are required for this use.
 - c) A Radio-Frequency Electromagnetic (RF-EME) Modeling Report was prepared for the project. The RF-EME report indicated that there are no physical or environmental impacts resulting from radio frequency emissions that would be detrimental to public health and safety. This report is consistent with applicable requirements of the Federal Communications Commission (FCC).
 - d) Staff conducted a site inspection on November 2, 2018 to verify that the site is suitable for this use.
 - e) The application, project plans, and related support materials submitted by the project applicant to the Monterey County RMA - Planning for the proposed development found in Project File PLN180361.
4. **FINDING:** **NO VIOLATIONS** - The subject property is in compliance with all rules and regulations pertaining to zoning uses, subdivision, and any other applicable provisions of the County's zoning ordinance. No violations exist on the property.
- EVIDENCE:**
- a) Staff reviewed Monterey County RMA - Planning and Building Services Department records and is not aware of any violations existing on subject property.
 - b) Staff conducted a site inspection on November 2, 2018 and researched County records to assess if any violation exists on the subject property.
 - c) The application, plans and supporting materials submitted by the project applicant to Monterey County RMA-Planning for the proposed development are found in Project File PLN180361.
5. **FINDING:** **CEQA (Exempt):** - The project is categorically exempt from environmental review and no unusual circumstances were identified to exist for the proposed project.
- EVIDENCE:**
- a) California Environmental Quality Act (CEQA) Guidelines Section 15303, categorically exempts the construction and location of new, small facilities or structures.
 - b) The project involves the construction of a new small wireless telecommunications facility, measuring 50 feet tall in a 1,600 square foot fenced area.

- c) No adverse environmental effects were identified during staff review of the development application during a site visit on November 2, 2018.
- d) None of the exceptions under CEQA Guidelines Section 15300.2 apply to this project. The proposed project will not result in cumulative impacts of successive projects of the same type in the same place, is not located within or near a scenic highway, road, or corridor, is not located on a hazardous waste site, and does not involve any change to a historical resource.
- e) The application, project plans, and related support materials submitted by the project applicant to Monterey County RMA-Planning for the proposed development found in Project File PLN180361.

7. FINDING

WIRELESS COMMUNICATIONS FACILITIES – The development of the proposed wireless communications facility will not significantly affect any designated public viewing area, scenic corridor, or any identified environmentally sensitive area or resources. The site is adequate for the proposed development of the wireless communications facility, and the applicant has demonstrated that it is the most adequate for the provision of services as required by the Federal Communications Commission (FCC). The proposed wireless communication facility complies with all applicable requirements of Monterey County Code (MCC) Section 21.64.310. The subject property on which the wireless communication facility is to be built is in compliance with all rules and regulations pertaining to zoning uses, subdivisions, and any other applicable provisions of MCC, and that all zoning violation abatement costs, if any, have been paid. The proposed telecommunication facility will not create a hazard for aircraft in flight.

- EVIDENCE:**
- a) The project consists of development of a wireless communications facility consisting of a 50-foot monopole, all associated transmission cables, a walk-in cabinet, and a 15kw DC Diesel Standby Generator. The site is located .75 miles off of Pine Canyon Road, King City.
 - b) Pursuant to the requirements in MCC Section 21.64.310(C)(5) the County analyzed potential visual impacts which could result from the placement of the facility, and finds that the proposed facility will not create a significant visual impact from adjacent properties or roadways. The subject property is not in a designated Visually Sensitive area pursuant to MCC Title 21 (Zoning Ordinance). The proposed facility will be visible from adjacent properties and from Pine Canyon Road; however, the facility will only be visible for a short time from Pine Canyon Road, and will be .75 miles away from the road. At 50 feet tall, the facility will be barely noticeable to the average passing motorist. The facility may be visible looking across the street from San Antonio Park within King City, however, this site is 2.5 miles from the proposed project and the staff site visit to this location revealed it could not be seen with the naked eye. Using a telephoto lens, an existing tower on an adjacent peak was barely visible; however, the proposed tower is at a higher elevation than this existing tower, and thus is more visible than the proposed tower would be. San Lorenzo County Park is located approximately 2.5 miles away from the proposed site. Visibility would be similar from this location; however, topography and vegetation

further limit views of the ridgeline from this location. Conditions have been incorporated that require non-glare color treatment, that would reduce the visual impacts in the event of technological advances, and that would require removal and restoration of the site in case of termination of use (Condition Nos. 7 and 9).

- c) Colocation opportunities were analyzed for the proposed project. There are no existing wireless facilities that could be used for colocation and meet coverage objectives. An existing antenna structure exists on the adjacent property, approximately 4,880 feet from the proposed tower location and higher in elevation by approximately 400 feet. This tower was determined to be too far away from the coverage objective to meet the project goal of providing coverage to the intended area. Additionally, there is no power available at the existing tower. The current operator uses solar power to generate power for their current use, which is for local wireless internet service to some surrounding residences. Expanding the solar footprint to serve the proposed use would require an approximately 50 square foot solar footprint, which is not feasible due to steeply sloping terrain. Additionally, the existing tower is not structurally suitable to accommodate the needs of the proposed project and would have to be replaced with a much larger tower to serve this use.
- d) The project is consistent with MCC Chapter 21.86, Airport Approach Zoning, and does not require review by the Monterey County Airport Land Use Commission. This project does not affect any aircraft zones identified in MCC Section 21.86.050, and the proposed height is within the limitations outlined in MCC Section 21.86.060.
- e) The project does not penetrate a FAR Part 77 Imaginary Surface. The project site is located approximately 4.5 miles (23,760 linear feet) from the mesa Del Rey Airport, the nearest public use airport. If deemed necessary by the FCC, warning lights would be located on top of the structure to prevent conflict with any aircraft when visibility is limited.
- f) The project planner reviewed the project application materials and plans, as well as the County's GIS database, to verify that the project on the subject parcel conforms to the plans listed above and that the site is suitable for this use. The application, plans, and supporting materials submitted by the project applicant to Monterey County RMA-Planning for the proposed development are found in Project File PLN180361.

6. **FINDING:** **ARCHAEOLOGICAL RESOURCES** – The project, as conditioned, is consistent with County Standards for archaeological resources.

- EVIDENCE:**
- a) The project site is in an area designated as having high archaeological sensitivity. Per Monterey County Code Section 21.66.050, a Phase 1 inventory report (LIB 190089) was prepared by Helix Environmental Planning. No records of archaeological resources were identified in the project vicinity and no archaeological resources were found.
 - b) The archeological report included recommendations for inadvertent discovery of cultural resources or human remains, which are consistent with Monterey County's standard Conditions of Approval. Condition 3 and Condition 4 have been added. To require work to halt within 50 meters of the find until a qualified professional archaeologist can evaluate it if

archaeological or cultural resources are discovered and work to halt the County Coroner to be contacted if human remains are discovered. The Native American Heritage Commission and the most likely decedent shall be contacted to provide recommendations if remains are determined to be Native American.

7. **FINDING:** **RIDGELINE DEVELOPMENT** – The project, as conditioned, is consistent with County Standards for Ridgeline Development.
- EVIDENCE:**
- a) Monterey County Code Section 21.06.950 defines ridgeline development as development on the crest of a hill which has the potential to create a silhouette or other substantially adverse impact when viewed from a common public viewing area. The proposed project would be visible as a silhouette from some locations on the crest of a hill, so the project represents potential ridgeline development; however, the proposed wireless facility will only be visible for a brief period of time from Pine Canyon road, and the impact will not be substantially adverse.
 - b) The proposed project is approvable pursuant to Monterey County Code Section 21.66.020 (Standards for Ridgeline Development), which states “A Use Permit for ridgeline development may be approved only if the following finding, based on substantial evidence, may be made: The ridgeline development, as conditioned by permit, will not create a substantially adverse visual impact when viewed from a common public viewing area.
 - c) The proposed facility will be visible from Pine Canyon Road; however, the facility will only be visible for a short time from Pine Canyon Road due to the rolling hill topography and the curves of the road in the subject area. Additionally, the facility will be 0.75 miles away from the road. At 50 feet tall, the facility will be barely noticeable to the average passing motorist.
 - d) The facility was thought to be potentially visible looking across the street from San Antonio Park within King City, however, this site is 2.5 miles from the proposed project and the staff site visit to this location revealed it could not be seen with the naked eye. Using a telephoto lens, an existing tower on an adjacent peak was barely visible; however, the proposed tower is at a higher elevation than this existing tower, and thus is more visible than the proposed tower would be.
 - e) San Lorenzo County Park is located approximately 2.4 miles away from the proposed site. Visibility would be similar from this location as from San Antonio Park; however, topography and vegetation further limit views of the ridgeline from this location.
 - f) Alternative locations on the valley floor and on a different peak on the opposite side of Pine Canyon road were evaluated (See Exhibits F and G of the staff report); however, coverage objects for rural residences in the opposing valley from the proposed location could not be achieved with any of the alternative locations. This project is a government funded Wireless Local Loop project specifically intended to bring service to rural residences, so not providing coverage to these areas is not an acceptable outcome for the applicant.

g) Conditions have been incorporated that require non-glare color treatment, that would reduce the visual impacts in the event of technological advances, and that would require removal and restoration of the site in case of termination of use (Condition Nos. 7 and 9).

8. **FINDING:** **APPEALABILITY** - The decision on this project may be appealed to the Board of Supervisors.

EVIDENCE: Section 21.80.040(D) of the Monterey County Zoning Ordinance (Title 21) states that the proposed project is appealable to the Board of Supervisors.

DECISION

NOW, THEREFORE, based on the above findings and evidence, the Zoning Administrator does hereby:

1. Find the project is a small structure, which qualifies for a Class 3 Categorical Exemption per Section 15303 of the CEQA Guidelines and does not meet any of the exceptions under Section 15300.2;
2. Approve a Use Permit to allow the development of a wireless telecommunications facility including a 50-foot-high communications monopole supporting equipment shelter
3. Approve a Use Permit to allow Ridgeline Development

PASSED AND ADOPTED this 10th day of July, 2019.

Brandon Swanson, Planning Commission Secretary

COPY OF THIS DECISION MAILED TO APPLICANT ON **DATE**

THIS APPLICATION IS APPEALABLE TO THE Board of Supervisors.

IF ANYONE WISHES TO APPEAL THIS DECISION, AN APPEAL FORM MUST BE COMPLETED AND SUBMITTED TO THE CLERK OF THE BOARD ALONG WITH THE APPROPRIATE FILING FEE ON OR BEFORE **DATE**

This decision, if this is the final administrative decision, is subject to judicial review pursuant to California Code of Civil Procedure Sections 1094.5 and 1094.6. Any Petition for Writ of Mandate must be filed with the Court no later than the 90th day following the date on which this decision becomes final.

NOTES

1. You will need a building permit and must comply with the Monterey County Building Ordinance in every respect.

Additionally, the Zoning Ordinance provides that no building permit shall be issued, nor any use conducted, otherwise than in accordance with the conditions and terms of the permit granted or until ten days after the mailing of notice of the granting of the permit by the appropriate authority, or after granting of the permit by the Board of Supervisors in the event of appeal.

Do not start any construction or occupy any building until you have obtained the necessary permits and use clearances from Monterey County RMA-Planning and RMA-Building Services Department office in Salinas.

2. This permit expires 3 years after the above date of granting thereof unless construction or use is started within this period.

Form Rev. 5-14-2014

Monterey County RMA Planning

DRAFT Conditions of Approval/Implementation Plan/Mitigation Monitoring and Reporting Plan

PLN180361

1. PD001(A) SPECIFIC USES ONLY (WIRELESS COMMUNICATION FACILITIES)

Responsible Department: RMA-Planning

Condition/Mitigation Monitoring Measure: This Use Permit (PLN180361) allows development of a 50-foot tall wireless communications facility. The property is located off of Pine Canyon Road (Assessor's Parcel Number 420-071-067-000), Central Salinas Valley Area Plan. This permit was approved in accordance with County ordinances and land use regulations subject to the following terms and conditions. The term "applicant" or "owner/applicant" as used in these conditions means Applicant* and its successors and assigns. Neither the uses nor the construction allowed by this permit shall commence unless and until all of the conditions of this permit are met to the satisfaction of the Director of the RMA - Planning. Any use or construction not in substantial conformance with the terms and conditions of this permit is a violation of County regulations and may result in modification or revocation of this permit and subsequent legal action. No use or construction other than that specified by this permit is allowed unless additional permits are approved by the appropriate authorities. To the extent that the County has delegated any condition compliance or mitigation monitoring to the Monterey County Water Resources Agency, the Water Resources Agency shall provide all information requested by the County and the County shall bear ultimate responsibility to ensure that conditions and mitigation measures are properly fulfilled. (RMA - Planning)

Compliance or Monitoring Action to be Performed: The Applicant (Applicant*) and its successors and assigns shall adhere to conditions and uses specified in the permit on an ongoing basis unless otherwise stated.

2. PD002 - NOTICE PERMIT APPROVAL

Responsible Department: RMA-Planning

Condition/Mitigation Monitoring Measure: The applicant shall record a Permit Approval Notice. This notice shall state:
"A Use Permit (Resolution Number _____) was approved by the Planning Commission for Assessor's Parcel Number 420-071-067-000 on July 10, 2019. The permit was granted subject to 10 conditions of approval which run with the land. A copy of the permit is on file with Monterey County RMA - Planning."

Proof of recordation of this notice shall be furnished to the Director of RMA - Planning prior to issuance of grading and building permits, Certificates of Compliance, or commencement of use, whichever occurs first and as applicable. (RMA - Planning)

Compliance or Monitoring Action to be Performed: Prior to the issuance of grading and building permits, certificates of compliance, or commencement of use, whichever occurs first and as applicable, the Owner/Applicant shall provide proof of recordation of this notice to the RMA - Planning.

3. PD003(B) - CULTURAL RESOURCES POSITIVE ARCHAEOLOGICAL REPORT

Responsible Department: RMA-Planning

Condition/Mitigation Monitoring Measure: If archaeological resources or human remains are accidentally discovered during construction, the following steps will be taken:

There shall be no further excavation or disturbance of the site or any nearby area reasonably suspected to overlie adjacent human remains until the coroner of the county in which the remain are discovered must be contacted to determine that no investigation of the cause of death is required.

If the coroner determines the remains to be Native American:

- The coroner shall contact the Native American Heritage Commission and RMA - Planning within 24 hours.
- The Native American Heritage Commission shall identify the person or persons from a recognized local tribe of the Esselen, Salinan, Costonoans/Ohlone and Chumash tribal groups, as appropriate, to be the most likely descendant.
- The most likely descendant may make recommendations to the landowner or the person responsible for the excavation work, for means of treating or disposing of, with appropriate dignity, the human remains and any associated grave goods as provided in Public Resources Code Section 5097.9 and 5097.993, Or

Where the following conditions occur, the landowner or his authorized representatives shall rebury the Native American human remains and associated grave goods with appropriate dignity on the property in a location not subject to further subsurface disturbance:

1. The Native American Heritage Commission is unable to identify a most likely descendant or the most likely descendant failed to make a recommendation within 24 hours after being notified by the commission.
2. The descendant identified fails to make a recommendation; or
3. The landowner or his authorized representative rejects the recommendation of the descendant, and the mediation by the Native American Heritage Commission fails to provide measures acceptable to the landowner.

(RMA - Planning)

Compliance or Monitoring Action to be Performed: Prior to the issuance of grading or building permits or approval of Subdivision Improvement Plans, whichever occurs first, the Owner/Applicant, per the archaeologist, shall submit the contract with a Registered Professional Archaeologist for on-call archaeological services should resources be discovered during construction activities. Submit the letter to the Director of the RMA – Planning for approval.

Prior to the issuance of grading or building permits and/or prior to the recordation of the final/parcel map, whichever occurs first, the Owner/Applicant shall include requirements of this condition as a note on all grading and building plans, on the Subdivision Improvement Plans, in the CC&Rs, and shall be included as a note on an additional sheet of the final/parcel map.

Prior to Final, the Owner/Applicant, per the Archaeologist, shall submit a report or letter from the archaeologist summarizing their methods, findings, and recommendations if their services are needed during construction or if no resources were found.

4. PD003(A) - CULTURAL RESOURCES NEGATIVE ARCHAEOLOGICAL REPORT

Responsible Department: RMA-Planning

Condition/Mitigation Monitoring Measure: If, during the course of construction, cultural, archaeological, historical or paleontological resources are uncovered at the site (surface or subsurface resources) work shall be halted immediately within 50 meters (165 feet) of the find until a qualified professional archaeologist can evaluate it. Monterey County RMA - Planning and a qualified archaeologist (i.e., an archaeologist registered with the Register of Professional Archaeologists) shall be immediately contacted by the responsible individual present on-site. When contacted, the project planner and the archaeologist shall immediately visit the site to determine the extent of the resources and to develop proper mitigation measures required for recovery.
(RMA - Planning)

Compliance or Monitoring Action to be Performed: The Owner/Applicant shall adhere to this condition on an on-going basis.

Prior to the issuance of grading or building permits and/or prior to the recordation of the final/parcel map, whichever occurs first, the Owner/Applicant shall include requirements of this condition as a note on all grading and building plans. The note shall state "Stop work within 50 meters (165 feet) of uncovered resource and contact Monterey County RMA - Planning and a qualified archaeologist immediately if cultural, archaeological, historical or paleontological resources are uncovered."

When contacted, the project planner and the archaeologist shall immediately visit the site to determine the extent of the resources and to develop proper mitigation measures required for the discovery.

5. PD041 - HEIGHT VERIFICATION

Responsible Department: RMA-Planning

Condition/Mitigation Monitoring Measure: The applicant shall have a benchmark placed upon the property and identify the benchmark on the building plans. The benchmark shall remain visible on-site until final building inspection. The applicant shall provide evidence from a licensed civil engineer or surveyor to the Director of RMA - Building Services for review and approval, that the height of the structure(s) from the benchmark is consistent with what was approved on the building permit associated with this project. (RMA - Planning and RMA - Building Services)

Compliance or Monitoring Action to be Performed: Prior to the issuance of grading or building permits, the Owner/Applicant shall have a benchmark placed upon the property and identify the benchmark on the building plans. The benchmark shall remain visible onsite until final building inspection.

Prior to the foundation pre-pour inspection, the Owner/Applicant shall provide evidence from a licensed civil engineer or surveyor, to the Director of RMA- Building Services for review and approval, that the height of first finished floor from the benchmark is consistent with what was approved on the building permit.

Prior to the final inspection, the Owner/Applicant/Engineer shall provide evidence from a licensed civil engineer or surveyor, to the Director of RMA- Building Services for review and approval, that the height of the structure(s) from the benchmark is consistent with what was approved on the building permit.

6. PD039(A) - WIRELESS INDEMNIFICATION

Responsible Department: RMA-Planning

Condition/Mitigation Monitoring Measure: The applicant agrees as a condition and in consideration of the approval of the permit to enter into an indemnification agreement with the County whereby the applicant agrees to defend, indemnify, and hold harmless the County, its officers, agents and employees from actions or claims of any description brought on account of any injury or damages sustained by any person or property resulting from the issuance of the permit and conduct of the activities authorized under said permit. Applicant shall obtain the permission of the owner on which the wireless communication facility is located to allow the recordation of said indemnification agreement, and the applicant shall cause said indemnification agreement to be recorded by the County Recorder as a prerequisite to the issuance of the building and/or grading permit. The County shall promptly notify the applicant of any such claim, action, or proceeding and the County shall cooperate fully in the defense thereof. The County may, at its sole discretion, participate in the defense of such action, but such participation shall not relieve applicant of its obligations under this condition. (RMA - Planning)

Compliance or Monitoring Action to be Performed: Prior to the issuance of grading or building permits, the Owner/Applicant shall submit signed and notarized Indemnification Agreement to the Director of RMA-Planning for review and signature by the County.

Prior to the issuance of grading or building permits, the Owner/Applicant shall submit proof of recordation of the Indemnification Agreement, as outlined, to RMA-Planning.

7. PD039(B) - WIRELESS REDUCE VISUAL IMPACTS

Responsible Department: RMA-Planning

Condition/Mitigation Monitoring Measure: The applicant shall agree in writing that if future technological advances allow for reducing the visual impacts of the telecommunication facility, the applicant shall make modifications to the facility accordingly to reduce the visual impact as part of the facility's normal replacement schedule. (RMA - Planning)

Compliance or Monitoring Action to be Performed: Prior to the issuance of grading or building permits, the Owner/Applicant shall submit, in writing, a declaration agreeing to comply with the terms of this condition RMA - Planning for review and approval.

8. PD039(C) - WIRELESS CO-LOCATION

Responsible Department: RMA-Planning

Condition/Mitigation Monitoring Measure: The applicant and/or successors assigns shall encourage co-location by other wireless carriers on this tower assuming appropriate permits are approved for co-location. Any expansion or additions of microwave dishes, antennas and/or similar appurtenances located on the monopole, which are not approved pursuant to this permit, are not allowed unless the appropriate authority approves additional permits or waivers. In any case, the overall height of the pole shall not exceed the specified height. (RMA - Planning)

Compliance or Monitoring Action to be Performed: On an on-going basis, the Owner/Applicant shall encourage co-location by other wireless carriers on this tower assuming appropriate permits are approved for co-location. The overall height of the pole shall not exceed 50 feet.

9. PD039(D) - WIRELESS REMOVAL

Responsible Department: RMA-Planning

Condition/Mitigation Monitoring Measure: If the applicant abandons the facility or terminates the use, the applicant shall remove the monopole, panel antennas, and equipment shelter. Upon such termination or abandonment, the applicant shall enter into a site restoration agreement subject to the approval of the Director of RMA - Planning and County Counsel. The site shall be restored to its natural state within six (6) months of the termination of use or abandonment of the site.
(RMA - Planning)

Compliance or Monitoring Action to be Performed: Prior to abandoning the facility or terminating the use, the Owner/Applicant shall submit a site restoration agreement to RMA - Planning subject to the approval of the RMA - Director of Planning and County Counsel.

Within 6 months of termination of use or abandonment of the site, the Owner Applicant shall restore the site to its natural state.

10. PD039(E) - WIRELESS EMISSION

Responsible Department: RMA-Planning

Condition/Mitigation Monitoring Measure: The facility must comply with Federal Communications Commission (FCC) emission standards. If the facility is in violation of FCC emission standards, the Director of RMA - Planning shall set a public hearing before the Appropriate Authority whereupon the appropriate authority may, upon a finding based on substantial evidence that the facility is in violation of the then existing FCC emission standards, revoke the permit or modify the conditions of the permit. (RMA - Planning)

Compliance or Monitoring Action to be Performed: Prior to commencement of use and on an on-going basis, the Owner/Applicant shall submit documentation demonstrating compliance with the FCC emission standards to the Director of RMA-Planning for review and approval.

On an on-going basis, if the facility is in violation of FCC emission standards, the Director of RMA-Planning shall set a public hearing before the Appropriate Authority to consider revocation or modification of the permit.



at&t

SITE NUMBER: CCL04830

SITE NAME: CUERVO HOLDINGS

FA NUMBER: 13787563
 PTN NUMBER: 3701A09BQ6, 3701A06S0B
 PACE NUMBER: MRSFR036694,
 MRSFR031111

SITE TYPE: TOWER/CWIC
 SITE ADDRESS: 51500 PINE CANYON
 KING CITY, CA 93930



5001 EXECUTIVE PKWY
 SAN RAMON, CA 94583



575 LENNON LANE, SUITE 125
 WALNUT CREEK, CA 94598

INFINIGY

ENGINEERING, LLP

26455 RANCHO PARKWAY SOUTH
 LAKE FOREST, CALIFORNIA 92630
 JOB NUMBER 469-001



SITE INFORMATION

PROPERTY OWNER: CUERVO HOLDINGS LP
 P.O. BOX 3310
 GREENFIELD, CA 93927

APPLICANT: AT&T MOBILITY
 ADDRESS: 5001 EXECUTIVE PKWY
 SAN RAMON, CA 94583

APPLICANT REPRESENTATIVE: VINCULUMS SERVICES
 ADDRESS: 575 LENNON LANE, SUITE 125
 WALNUT CREEK, CA 94598

LATITUDE (NAD 83): 36° 10' 33.02" N
 LONGITUDE (NAD 83): 121° 10' 08.09" W
 ELEVATION: 1176.8' (AMSL)
 OCCUPANCY: UTILITY
 CONSTRUCTION TYPE: B
 APN #: 420-071-067
 ZONING JURISDICTION: COUNTY OF MONTEREY
 CURRENT ZONING: -
 PROPOSED USE: UNMANNED TELECOM FACILITY

PROJECT TEAM

PROJECT MANAGER: VINCULUMS SERVICES
 575 LENNON LANE, SUITE 125
 WALNUT CREEK, CA 94598
 CONTACT: MICHELLE PHIPPEN
 PHONE: (925) 895-3734
 EMAIL: mphippen@vinculums.com

ARCHITECTURAL & ENGINEERING: INFINIGY ENGINEERING, LLP
 26455 RANCHO PKWY SOUTH
 LAKE FOREST, CA 92630
 CONTACT: DAN CONNELL
 PHONE: (949) 306-4644
 dconnell@infinigy.com

APPLICANT: AT&T MOBILITY
 5001 EXECUTIVE PARKWAY
 SAN RAMON, CA 94583

SITE ACQUISITION: TSJ CONSULTING INC.
 27130A PASEO ESPADA
 SUITE #1426
 SAN JUAN CAPISTRANO, CA 92675
 CONTACT: TOM JOHNSON
 PHONE: (925) 785-3727
 tom@tsjconsultinginc.com

CONSTRUCTION MANAGER: VINCULUMS SERVICES
 575 LENNON LANE, SUITE 125
 WALNUT CREEK, CA 94598
 CONTACT: FLOYD GREEN
 PHONE: (480) 528-1927
 EMAIL: fgreen@vinculums.com

LOCATION MAPS

VICINITY MAP

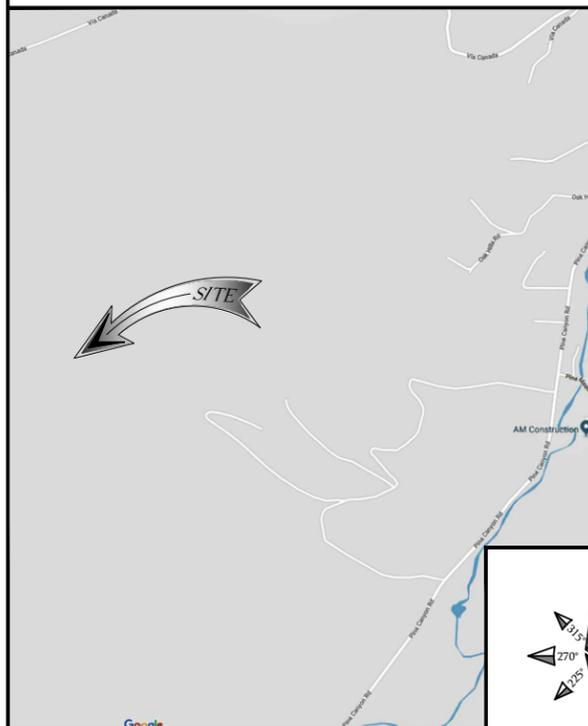

LOCAL MAP

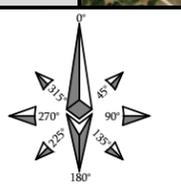

PROJECT DESCRIPTION

AT&T WIRELESS PROPOSES TO CONSTRUCT A NEW WIRELESS FACILITY. THE SCOPE WILL CONSIST OF THE FOLLOWING:

- INSTALL (1) NEW CWIC (WALK IN CABINET) WITHIN NEW 7'-0" HIGH CHAIN LINK FENCE TELECOMMUNICATION COMPOUND
- INSTALL (1) AT&T 50'-0" HIGH CO-LOCATABLE MONOPOLE TOWER
- INSTALL (3) RAYCAP ARRAY SURGE SUPPRESSORS AT ANTENNA ELEVATION
- INSTALL (1) NEW AT&T GPS UNIT ON WIC
- INSTALL (3) NEW DC-6 SURGE SUPPRESSORS
- INSTALL (2) NEW DC-12 SURGE SUPPRESSORS
- INSTALL (8) NEW AT&T ANTENNAS ON PROPOSED ANTENNA ARRAYS
- INSTALL (14) NEW RRU'S ON NEW MONOPOLE TOWER
- INSTALL (1) NEW AT&T 30KW DIESEL GENERATOR
- INSTALL (1) NEW AT&T 4' MICROWAVE DISH WITH (4) NOKIA HQAM ODU'S
- INSTALL (1) NEW MPR 9500 SHELF IN (N) FIF RACK
- INSTALL (4) NEW CNT 400 COAX CABLES & (4) NEW FIBER CABLES

DRAWING INDEX

SHEET NO:	TITLE
T-1	TITLE SHEET
GN-1	GENERAL NOTES
GN-2	GENERAL NOTES
GN-3	GENERAL NOTES
F-1	FIRE DEPARTMENT / BATTERY INFORMATION
LS-1	TOPOGRAPHIC SURVEY
A-0	OVERALL SITE PLAN
A-1	SITE PLAN, ENLARGED SITE PLAN, ANTENNA / RRU SCHEDULE
A-2	EQUIPMENT LAYOUT
A-3	ANTENNA LAYOUT
A-4	ELEVATIONS
D-1	EQUIPMENT SPECS & DETAILS
D-2	EQUIPMENT SPECS & DETAILS
D-3	EQUIPMENT SPECS & DETAILS
D-4	EQUIPMENT SPECS & DETAILS
E-1	ELECTRICAL SITE PLAN
E-2	SINGLE LINE DIAGRAM, PANEL SCHEDULE, NOTES & DETAILS
G-1	GROUNDING PLAN, KEY NOTES, LEGEND & DETAILS
G-2	GROUNDING DETAILS & NOTES

DRIVING DIRECTIONS

DIRECTIONS FROM AT&T SAN RAMON OFFICE:

GET ON I-680 S FROM CAMINO RAMON AND BOLLINGER CANYON RD
 FOLLOW I-680 S AND US-101 S TO JOLON RD IN MONTEREY COUNTY.
 TAKE EXIT 283 FROM US-101 S
 TAKE PINE CANYON RD TO 51500 PINE CANYON RD

DO NOT SCALE DRAWINGS

SUBCONTRACTOR SHALL VERIFY ALL PLANS & EXISTING DIMENSIONS & CONDITIONS ON THE JOB SITE & SHALL IMMEDIATELY NOTIFY THE ENGINEER IN WRITING OF ANY DISCREPANCIES BEFORE PROCEEDING WITH THE WORK OR BE RESPONSIBLE FOR SAME.

IF USING 11"x17" PLOT, DRAWINGS WILL BE HALF SCALE

CODE COMPLIANCE

ALL WORKS AND MATERIALS SHALL BE PERFORMED AND INSTALLED IN ACCORDANCE WITH THE CURRENT EDITIONS OF THE FOLLOWING CODES AS ADOPTED BY THE LOCAL GOVERNING AUTHORITIES. NOTHING IN THESE PLANS IS TO BE CONSTRUED TO PERMIT WORK NOT CONFORMING TO THE LATEST EDITIONS OF THE FOLLOWING CODES.

2016 CALIFORNIA BUILDING CODE	2016 CALIFORNIA PLUMBING CODE
2016 CALIFORNIA TITLE 24	2016 CALIFORNIA MECHANICAL CODE
2016 CALIFORNIA FIRE CODE	2016 INTERNATIONAL BUILDING CODE
2016 CALIFORNIA RESIDENTIAL CODE	2016 NATIONAL ELECTRIC CODE
2016 CALIFORNIA ENERGY CODE	TIA/EIA-222-G OR LATEST EDITION

IT IS A VIOLATION OF LAW FOR ANY PERSON, UNLESS THEY ARE ACTING UNDER THE DIRECTION OF A LICENSED PROFESSIONAL ENGINEER, TO ALTER THIS DOCUMENT.

CCL04830
 CUERVO HOLDINGS
 51500 PINE CANYON
 KING CITY, CA 93930
 TOWER/CWIC

SHEET TITLE
 TITLE SHEET

SHEET NUMBER

T-1

GENERAL CONSTRUCTION NOTES

- FOR THE PURPOSE OF CONSTRUCTION DRAWINGS, THE FOLLOWING DEFINITIONS SHALL APPLY:
GENERAL CONTRACTOR – OVERLAND CONTRACTING INC. (B&V)
SUBCONTRACTOR – CONTRACTOR (CONSTRUCTION)
OWNER – AT&T
- ALL SITE WORK SHALL BE COMPLETED AS INDICATED ON THE DRAWINGS AND AT&T PROJECT SPECIFICATIONS.
- GENERAL CONTRACTOR AND SUBCONTRACTOR SHALL VISIT THE SITE AND SHALL FAMILIARIZE HIMSELF WITH ALL CONDITIONS AFFECTING THE PROPOSED WORK AND SHALL MAKE PROVISIONS. GENERAL CONTRACTOR AND SUBCONTRACTOR SHALL BE RESPONSIBLE FOR FAMILIARIZING HIMSELF WITH ALL CONTRACT DOCUMENTS, FIELD CONDITIONS, DIMENSIONS, AND CONFIRMING THAT THE WORK MAY BE ACCOMPLISHED AS SHOWN PRIOR TO PROCEEDING WITH CONSTRUCTION. ANY DISCREPANCIES SHALL BE BROUGHT TO THE ATTENTION OF THE ENGINEER PRIOR TO THE COMMENCEMENT OF WORK.
- ALL MATERIALS FURNISHED AND INSTALLED SHALL BE IN STRICT ACCORDANCE WITH ALL APPLICABLE CODES, REGULATIONS, AND ORDINANCES. GENERAL CONTRACTOR SHALL ISSUE ALL APPROPRIATE NOTICES AND COMPLY WITH ALL LAWS, ORDINANCES, RULES, REGULATIONS, AND LAWFUL ORDERS OF ANY PUBLIC AUTHORITY REGARDING THE PERFORMANCE OF WORK.
- ALL WORK CARRIED OUT SHALL COMPLY WITH ALL APPLICABLE MUNICIPAL AND UTILITY COMPANY SPECIFICATIONS AND LOCAL JURISDICTIONAL CODES, ORDINANCES, AND APPLICABLE REGULATIONS.
- UNLESS NOTED OTHERWISE, THE WORK SHALL INCLUDE FURNISHING MATERIALS, EQUIPMENT, APPURTENANCES, AND LABOR NECESSARY TO COMPLETE ALL INSTALLATIONS AS INDICATED ON THE DRAWINGS.
- PLANS ARE NOT TO BE SCALED. THESE PLANS ARE INTENDED TO BE A DIAGRAMMATIC OUTLINE ONLY UNLESS OTHERWISE NOTED. DIMENSIONS SHOWN ARE TO FINISH SURFACES UNLESS OTHERWISE NOTED. SPACING BETWEEN EQUIPMENT IS THE MINIMUM REQUIRED CLEARANCE. THEREFORE, IT IS CRITICAL TO FIELD VERIFY DIMENSIONS, SHOULD THERE BE ANY QUESTIONS REGARDING THE CONTRACT DOCUMENTS, THE SUBCONTRACTOR SHALL BE RESPONSIBLE FOR OBTAINING A CLARIFICATION FROM THE ENGINEER PRIOR TO PROCEEDING WITH THE WORK. DETAILS ARE INTENDED TO SHOWN DESIGN INTENT. MODIFICATIONS MAY BE REQUIRED TO SUIT JOB DIMENSIONS OR CONDITIONS AND SUCH MODIFICATIONS SHALL BE INCLUDED AS PART OF WORK AND PREPARED BY THE ENGINEER PRIOR TO PROCEEDING WITH WORK.
- THE SUBCONTRACTOR SHALL INSTALL ALL EQUIPMENT AND MATERIALS IN ACCORDANCE WITH MANUFACTURER'S RECOMMENDATIONS UNLESS SPECIFICALLY STATED OTHERWISE.
- IF THE SPECIFIED EQUIPMENT CANNOT BE INSTALLED AS SHOWN ON THESE DRAWINGS, THE SUBCONTRACTOR SHALL PROPOSE AN ALTERNATIVE INSTALLATION SPACE FOR APPROVAL BY THE ENGINEER PRIOR TO PROCEEDING.
- GENERAL CONTRACTOR SHALL BE RESPONSIBLE FOR THE SAFETY OF WORK AREA, ADJACENT AREAS AND BUILDING OCCUPANTS THAT ARE LIKELY TO BE AFFECTED BY THE WORK UNDER THIS CONTRACT. WORK SHALL CONFIRM TO ALL OSHA REQUIREMENTS AND THE LOCAL JURISDICTION.
- GENERAL CONTRACTOR SHALL COORDINATE WORK AND SCHEDULE WORK ACTIVITIES WITH OTHER DISCIPLINES.
- ERECTION SHALL BE DONE IN A WORKMANLIKE MANNER BY COMPETENT EXPERIENCED WORKMAN IN ACCORDANCE WITH APPLICABLE CODES AND THE BEST ACCEPTED PRACTICE. ALL MEMBERS SHALL BE LAID PLUMB AND TRUE AS INDICATED ON THE DRAWINGS.
- SEAL PENETRATIONS THROUGH FIRE RATED AREAS WITH UL LISTED MATERIALS APPROVED BY LOCAL JURISDICTION. SUBCONTRACTOR SHALL KEEP AREA CLEAN, HAZARD FREE, AND DISPOSE OF ALL DEBRIS.
- WORK PREVIOUSLY COMPLETED IS REPRESENTED BY LIGHT SHADED LINES AND NOTES. THE SCOPE OF WORK FOR THIS PROJECT IS REPRESENTED BY DARK SHADED LINES AND NOTES. SUBCONTRACTOR SHALL NOTIFY THE GENERAL CONTRACTOR OF ANY EXISTING CONDITIONS THAT DEVIATE FROM THE DRAWINGS PRIOR TO BEGINNING CONSTRUCTION.
- SUBCONTRACTOR SHALL PROVIDE WRITTEN NOTICE TO THE CONSTRUCTION MANAGER 48 HOURS PRIOR TO COMMENCEMENT OF WORK.
- THE SUBCONTRACTOR SHALL PROTECT EXISTING IMPROVEMENTS, PAVEMENTS, CURBS, LANDSCAPING AND STRUCTURES. ANY DAMAGED PART SHALL BE REPAIRED AT SUBCONTRACTOR'S EXPENSE TO THE SATISFACTION OF THE OWNER.
- THE SUBCONTRACTOR SHALL CONTACT UTILITY LOCATING SERVICES PRIOR TO THE START OF CONSTRUCTION.
- GENERAL CONTRACTOR SHALL COORDINATE AND MAINTAIN ACCESS FOR ALL TRADES AND SUBCONTRACTORS TO THE SITE AND/OR BUILDING.
- THE GENERAL CONTRACTOR SHALL BE RESPONSIBLE FOR SECURITY OF THE SITE FOR THE DURATION OF CONSTRUCTION UNTIL JOB COMPLETION.
- THE GENERAL CONTRACTOR SHALL MAINTAIN IN GOOD CONDITION ONE COMPLETE SET OF PLANS WITH ALL REVISIONS, ADDENDA, AND CHANGE ORDERS ON THE PREMISES AT ALL TIMES.
- THE GENERAL CONTRACTOR AND SUBCONTRACTOR SHALL PROVIDE PORTABLE FIRE EXTINGUISHERS WITH A RATING OF NOT LESS THAN 2-A OR 2-A:10-B:C AND SHALL BE WITHIN 25 FEET OF TRAVEL DISTANCE TO ALL PORTIONS OF WHERE THE WORK IS BEING COMPLETED DURING CONSTRUCTION.
- ALL EXISTING ACTIVE SEWER, WATER, GAS, ELECTRIC, AND OTHER UTILITIES SHALL BE PROTECTED AT ALL TIMES, AND WHERE REQUIRED FOR THE PROPER EXECUTION OF THE WORK, SHALL BE RELOCATED AS DIRECTED BY THE ENGINEER. EXTREME CAUTION SHOULD BE USED BY THE SUBCONTRACTOR WHEN EXCAVATING OR DRILLING PIERS AROUND OR NEAR UTILITIES. SUBCONTRACTOR SHALL PROVIDE SAFETY TRAINING FOR THE WORKING CREW. THIS SHALL INCLUDE BUT NOT BE LIMITED TO A) FALL PROTECTION, B) CONFINED SPACE, C) ELECTRICAL SAFETY, AND D) TRENCHING & EXCAVATION.
- ALL EXISTING INACTIVE SEWER, WATER, GAS, ELECTRIC, AND OTHER UTILITIES, WHICH INTERFERE WITH THE EXECUTION OF THE WORK, SHALL BE REMOVED, CAPPED, PLUGGED OR OTHERWISE DISCONNECTED AT POINTS WHICH WILL NOT INTERFERE WITH THE EXECUTION OF THE WORK, AS DIRECTED BY THE RESPONSIBLE ENGINEER, AND SUBJECT TO THE APPROVAL OF THE OWNER AND/OR LOCAL UTILITIES.
- THE AREAS OF THE OWNER'S PROPERTY DISTURBED BY THE WORK AND NOT COVERED BY THE TOWER, EQUIPMENT OR DRIVEWAY, SHALL BE GRADED TO A UNIFORM SLOPE, AND STABILIZED TO PREVENT EROSION.
- SUBCONTRACTOR SHALL MINIMIZE DISTURBANCE TO THE EXISTING SITE DURING CONSTRUCTION. EROSION CONTROL MEASURES, IF REQUIRED DURING CONSTRUCTION, SHALL BE IN CONFORMANCE WITH THE FEDERAL AND LOCAL JURISDICTION FOR EROSION AND SEDIMENT CONTROL.
- NO FILL OR EMBANKMENT MATERIAL SHALL BE PLACED ON FROZEN GROUNDING. FROZEN MATERIALS, SNOW OR ICE SHALL NOT BE PLACED IN ANY FILL OR EMBANKMENT.

GENERAL NOTES

- THE SUBGRADE SHALL BE BROUGHT TO A SMOOTH UNIFORM GRADE AND COMPACTED TO 95 PERCENT STANDARD PROCTOR DENSITY UNDER PAVEMENT AND STRUCTURES AND 80 PERCENT STANDARD PROCTOR DENSITY IN OPEN SPACE. ALL TRENCHES IN PUBLIC RIGHT OF WAY SHALL BE BACKFILLED WITH FLOWABLE FILL OR OTHER MATERIAL PRE-APPROVED BY THE LOCAL JURISDICTION.
- ALL NECESSARY RUBBISH, STUMPS, DEBRIS, STICKS, STONES, AND OTHER REFUSE SHALL BE REMOVED FROM THE SITE AND DISPOSED OF IN A LAWFUL MANNER.
- ALL BROCHURES, OPERATING AND MAINTENANCE MANUALS, CATALOGS, SHOP DRAWINGS, AND OTHER DOCUMENTS SHALL BE TURNED OVER TO THE GENERAL CONTRACTOR AT COMPLETION OF CONSTRUCTION AND PRIOR TO PAYMENT.
- SUBCONTRACTOR SHALL SUBMIT A COMPLETE SET OF AS-BUILT REDLINES TO THE GENERAL CONTRACTOR UPON COMPLETION OF PROJECT AND PRIOR TO FINAL PAYMENT.
- SUBCONTRACTOR SHALL LEAVE PREMISES IN A CLEAN CONDITION.
- THE PROPOSED FACILITY WILL BE UNMANNED AND DOES NOT REQUIRE POTABLE WATER OR SEWER SERVICE, AND IS NOT FOR HUMAN HABITAT (NO HANDICAP ACCESS REQUIRED).
- OCCUPANCY IS LIMITED TO PERIODIC MAINTENANCE AND INSPECTION, APPROXIMATELY 2 TIMES PER MONTH, BY AT&T TECHNICIANS.
- NO OUTDOOR STORAGE OR SOLID WASTE CONTAINERS ARE PROPOSED.
- ALL MATERIAL SHALL BE FURNISHED AND WORK SHALL BE PERFORMED IN ACCORDANCE WITH THE LATEST REVISION AT&T MOBILITY GROUNDING STANDARD "TECHNICAL SPECIFICATION FOR CONSTRUCTION OF GSM/GPRS WIRELESS SITES" AND "TECHNICAL SPECIFICATION FOR FACILITY GROUNDING". IN CASE OF A CONFLICT BETWEEN THE CONSTRUCTION SPECIFICATION AND THE DRAWINGS, THE DRAWINGS SHALL GOVERN.
- SUBCONTRACTORS SHALL BE RESPONSIBLE FOR OBTAINING ALL PERMITS AND INSPECTIONS REQUIRED FOR CONSTRUCTION. IF SUBCONTRACTOR CANNOT OBTAIN A PERMIT, THEY MUST NOTIFY THE GENERAL CONTRACTOR IMMEDIATELY.
- SUBCONTRACTOR SHALL REMOVE ALL TRASH AND DEBRIS FROM THE SITE ON A DAILY BASIS.
- INFORMATION SHOWN ON THESE DRAWINGS WAS OBTAINED FROM SITE VISITS AND/OR DRAWINGS PROVIDED BY THE SITE OWNER. CONTRACTORS SHALL NOTIFY THE ENGINEER OF ANY DISCREPANCIES PRIOR TO ORDERING MATERIAL OR PROCEEDING WITH CONSTRUCTION.
- NO WHITE STROBIC LIGHTS ARE PERMITTED. LIGHTING IF REQUIRED, WILL MEET FAA STANDARDS AND REQUIREMENTS.
- ALL COAXIAL CABLE INSTALLATIONS TO FOLLOW MANUFACTURER'S INSTRUCTIONS AND RECOMMENDATIONS.
- NO NOISE, SMOKE, DUST, ODOR, OR VIBRATIONS WILL RESULT FROM THIS FACILITY. (DELETE THIS NOTE IF THE SITE WILL HAVE A GENERATOR)
- NO ADDITIONAL PARKING TO BE PROPOSED. EXISTING ACCESS AND PARKING TO REMAIN. (REVISE THIS NOTE ACCORDING TO THE SITE CONFIGURATION)
- NO LANDSCAPING IS PROPOSED AT THIS SITE. (REVISE THIS NOTE ACCORDING TO THE SITE CONFIGURATION)

ABBREVIATIONS

2

A.B.	ANCHOR BOLT	GRND.	GROUND
ABV.	ABOVE	HDR.	HEADER
ACCA	ANTENNA CABLE COVER ASSEMBLY	HGR.	HANGER
ADD'L	ADDITIONAL	HT.	HEIGHT
A.F.F.	ABOVE FINISHED FLOOR	ICGB.	ISOLATED COPPER GROUND BUS
A.F.G.	ABOVE FINISHED GRADE	IN.(#)	INCH(ES)
ALUM.	ALUMINUM	INT.	INTERIOR
ALT.	ALTERNATE	LB.(#)	POUND(S)
ANT.	ANTENNA	LB.	LAG BOLTS
APPRX.	APPROXIMATE(LY)	L.F.	LINEAR FEET (FOOT)
ARCH.	ARCHITECT(URAL)	L.	LONG(TUDINAL)
AWG.	AMERICAN WIRE GAUGE	MAS.	MASONRY
BLDG.	BUILDING	MAX.	MAXIMUM
BLK.	BLOCK	M.B.	MACHINE BOLT
BLKG.	BLOCKING	MECH.	MECHANICAL
BM.	BEAM	MFR.	MANUFACTURER
B.N.	BORDINARY NAILING	MIN.	MINIMUM
BTCW.	BARE TINNED COPPER WIRE	MISC.	MISCELLANEOUS
B.O.F.	BOTTOM OF FOOTING	MTL.	METAL
B/U	BACK-UP CABINET	(P)	NEW
CAB.	CABINET	NO.(#)	NUMBER
CANT.	CANTILEVER(ED)	N.T.S.	NOT TO SCALE
C.I.P.	CAST IN PLACE	O.C.	ON CENTER
CLG.	CEILING	OPNG.	OPENING
CLR.	CLEAR	P/C	PRECAST CONCRETE
COL.	COLUMN	P.CS	PERSONAL COMMUNICATION SERVICES
CONC.	CONCRETE	PLY.	PLYWOOD
CONN.	CONNECTION(OR)	PPC	POWER PROTECTION CABINET
CONST.	CONSTRUCTION	PRC	PRIMARY RADIO CABINET
CONT.	CONTINUOUS	P.S.F.	POUNDS PER SQUARE FOOT
d	PENNY (NAILS)	P.S.I.	POUNDS PER SQUARE INCH
DBL.	DOUBLE	P.T.	PRESSURE TREATED
DEPT.	DEPARTMENT	PWR.	POWER (CABINET)
D.F.	DOUGLAS FIR	QTY.	QUANTITY
DIA.	DIAMETER	RAD.(R)	RADIUS
DIAG.	DIAGONAL	REF.	REFERENCE
DIM.	DIMENSION	REINF.	REINFORCEMENT(ING)
DWG.	DRAWING(S)	REQ'D.	REQUIRED
DWL.	DOWEL(S)	RGS.	RIGID GALVANIZED STEEL
EA.	EACH	SCH.	SCHEDULE
EL.	ELEVATION	SHT.	SHEET
ELEC.	ELECTRICAL	SM.	SIMILAR
ELEV.	ELEVATOR	SPEC.	SPECIFICATION(S)
EMT.	ELECTRICAL METALLIC TUBING	SQ.	SQUARE
E.N.	EDGE NAIL	S.S.	STAINLESS STEEL
ENG.	ENGINEER	STD.	STANDARD
EQ.	EQUAL	STL.	STEEL
EXP.	EXPANSION	STRUC.	STRUCTURAL
EXST.(P)	(P)	TEMP.	TEMPORARY
EXT.	EXTERIOR	THK.(NESS)	THICK(NESS)
FAB.	FABRICATION(OR)	T.N.	TOE NAIL
F.F.	FINISH FLOOR	T.O.A.	TOP OF ANTENNA
F.G.	FINISH GRADE	T.O.C.	TOP OF CURB
FIN.	FINISH(ED)	T.O.F.	TOP OF FOUNDATION
FLR.	FLOOR	T.O.P.	TOP OF PLATE (PARAPET)
FDN.	FOUNDATION	T.O.S.	TOP OF STEEL
F.O.C.	FACE OF CONCRETE	T.O.W.	TOP OF WALL
F.O.M.	FACE OF MASONRY	TYP.	TYPICAL
F.O.S.	FACE OF STUD	U.G.	UNDER GROUND
F.F.	FACE OF WALL	U.L.L.	UNDERWRITERS LABORATORY
F.S.	FINISH SURFACE	U.N.O.	UNLESS NOTED OTHERWISE
FT.(')	FOOT(FEET)	V.I.F.	VERIFY IN FIELD
FTG.	FOOTING	W	WIDE(WIDTH)
G.	GROWTH (CABINET)	W/	WITH
GA.	GAUGE	WD.	WOOD
GI.	GALVANIZE(D)	W.P.	WEATHERPROOF
G.F.I.	GROUND FAULT CIRCUIT INTERRUPTER	WT.	WEIGHT
GLB.(GLU-LAM)	GLUE LAMINATED BEAM	€	CENTERLINE
GPS	GLOBAL POSITIONING SYSTEM	ℓ	PLATE

	NEW ANTENNA		GROUT OR PLASTER
	EXISTING ANTENNA		EXISTING BRICK
	GROUND ROD		EXISTING MASONRY
	GROUND BUS BAR		CONCRETE
	MECHANICAL GRND. CONN.		EARTH
	CADWELD		GRAVEL
	GROUND ACCESS WELL		PLYWOOD
	ELECTRIC BOX		SAND
	TELEPHONE BOX		WOOD CONT.
	(P) MONO-EUCALYPTUS		WOOD BLOCKING
	SET POINT		STEEL
	REVISION		CENTERLINE
	GRID REFERENCE		PROPERTY/LEASE LINE
	DETAIL REFERENCE		MATCH LINE
	ELEVATION REFERENCE		WORK POINT
	SECTION REFERENCE		GROUND CONDUCTOR
			TELEPHONE CONDUIT
			ELECTRICAL CONDUIT
			COAXIAL CABLE
			OVERHEAD SERVICE CONDUCTORS
			CHAIN LINK FENCING

LEGEND

3



5001 EXECUTIVE PKWY
SAN RAMON, CA 94583



575 LENNON LANE, SUITE 125
WALNUT CREEK, CA 94598

INFINIGY
ENGINEERING, LLP

26455 RANCHO PARKWAY SOUTH
LAKE FOREST, CALIFORNIA 92630

JOB NUMBER 469-001

REV	DATE	DESCRIPTION
3	06/19/19	CHANGE TO MONOPOLE
2	05/16/19	90% CONSTRUCTION DRAWINGS
1	04/26/19	90% CONSTRUCTION DRAWINGS
0	04/17/19	90% CONSTRUCTION DRAWINGS

IT IS A VIOLATION OF LAW FOR ANY PERSON, UNLESS THEY ARE ACTING UNDER THE DIRECTION OF A LICENSED PROFESSIONAL ENGINEER, TO ALTER THIS DOCUMENT.

CCL04830
CUERVO HOLDINGS
51500 PINE CANYON
KING CITY, CA 93930
TOWER/CWIC

SHEET TITLE
GENERAL NOTES

SHEET NUMBER
GN-1

1

SITE WORK & DRAINAGE

PART 1 – GENERAL

CLEARING, GRUBBING, STRIPPING, EROSION CONTROL, SURVEY, LAYOUT, SUBGRADE PREPARATION AND FINISH GRADING AS REQUIRED TO COMPLETE THE PROPOSED WORK SHOWN IN THESE PLANS.

1.1 REFERENCES:

- A. DOT (STATE DEPARTMENT OF TRANSPORTATION STANDARD SPECIFICATIONS FOR HIGHWAY CONSTRUCTION—CURRENT EDITION).
- B. ASTM (AMERICAN SOCIETY FOR TESTING AND MATERIALS).
- C. OSHA (OCCUPATION SAFETY AND HEALTH ADMINISTRATION).

1.2 INSPECTION AND TESTING:

- A. FIELD TESTING OF EARTHWORK COMPACTION AND CONCRETE CYLINDERS SHALL BE PERFORMED BY SUBCONTRACTORS INDEPENDENT TESTING LAB. THIS WORK TO BE COORDINATED BY THE SUBCONTRACTOR.
- B. ALL WORK SHALL BE INSPECTED AND RELEASED BY THE GENERAL CONTRACTOR WHO SHALL CARRY OUT THE GENERAL INSPECTION OF THE WORK WITH SPECIFIC CONCERN TO PROPER PERFORMANCE OF THE WORK AS SPECIFIED AND/OR CALLED FOR ON THE DRAWINGS. IT IS THE SUBCONTRACTOR'S RESPONSIBILITY TO REQUEST TIMELY INSPECTIONS PRIOR TO PROCEEDING WITH FURTHER WORK THAT WOULD MAKE PARTS OF WORK INACCESSIBLE OR DIFFICULT TO INSPECT.

1.3 SITE MAINTENANCE AND PROTECTION:

- A. PROVIDE ALL NECESSARY JOB SITE MAINTENANCE FROM COMMENCEMENT OF WORK UNTIL COMPLETION OF THE SUBCONTRACT.
 - B. AVOID DAMAGE TO THE SITE AND TO EXISTING FACILITIES, STRUCTURES, TREES, AND SHRUBS DESIGNATED TO REMAIN. TAKE PROTECTIVE MEASURES TO PREVENT EXISTING FACILITIES THAT ARE NOT DESIGNATED FOR REMOVAL FROM BEING DAMAGED BY THE WORK.
 - C. KEEP SITE FREE OF ALL PONDING WATER.
 - D. PROVIDE EROSION CONTROL MEASURES IN ACCORDANCE WITH STATE DOT AND EPA REQUIREMENTS.
 - E. PROVIDE AND MAINTAIN ALL TEMPORARY FENCING, BARRICADES, WARNING SIGNALS AND SIMILAR DEVICES NECESSARY TO PROTECT AGAINST THEFT FROM PROPERTY DURING THE ENTIRE PERIOD OF CONSTRUCTION. REMOVE ALL SUCH DEVICES UPON COMPLETION OF THE WORK.
 - F. EXISTING UTILITIES: DO NOT INTERRUPT EXISTING UTILITIES SERVING FACILITIES OCCUPIED BY THE OWNER OR OTHERS. EXCEPT WHEN PERMITTED IN WRITING BY THE ENGINEER AND THEN ONLY AFTER ACCEPTABLE TEMPORARY UTILITY SERVICES HAVE BEEN PROVIDED.
1. PROVIDE A MINIMUM 48-HOUR NOTICE TO THE ENGINEER AND RECEIVE WRITTEN NOTICE TO PROCEED BEFORE INTERRUPTING ANY UTILITY SERVICE.

PART 2 – PRODUCTS

- 2.1 SUITABLE BACKFILL: ASTM D2321 (CLASS I, II, III OR IVA) FREE FROM FROZEN LUMPS, REFUSE, STONES OR ROCKS LARGER THAN 3 INCHES IN ANY DIMENSION OR OTHER MATERIAL THAT MAY MAKE THE INORGANIC MATERIAL UNSUITABLE FOR BACKFILL.
- 2.2 NON-POROUS GRANULAR EMBANKMENT AND BACKFILL: ASTM D2321 (CLASS III, IVA OR IVB) COARSE AGGREGATE. FREE FROM FROZEN LUMPS, REFUSE, STONES OR ROCKS LARGER THAN 3 INCHES IN ANY DIMENSION OR OTHER MATERIAL THAT MAY MAKE THE INORGANIC MATERIAL UNSUITABLE FOR BACKFILL.
- 2.3 POROUS GRANULAR EMBANKMENT AND BACKFILL: ASTM D2321 (CLASS IA, IB OR ID) COARSE AGGREGATE. FREE FROM FROZEN LUMPS, REFUSE, STONES OR ROCKS LARGER THAN 3 INCHES IN ANY DIMENSION OR OTHER MATERIAL THAT MAY MAKE THE INORGANIC MATERIAL UNSUITABLE FOR BACKFILL.
- 2.4 SELECT STRUCTURAL FILL: GRANULAR FILL MATERIALS MEETING THE REQUIREMENTS OF ASTM E850-95. FOR USE AROUND AND UNDER STRUCTURES WHERE STRUCTURAL FILL MATERIAL ARE REQUIRED.
- 2.5 GRANULAR BEDDING AND TRENCH BACKFILL: WELL-GRADED SAND MEETING THE GRADATION REQUIREMENTS OF ASTM D2487 (SE OR SW-SM).
- 2.6 COARSE AGGREGATE FOR ACCESS ROAD SUBBASE COURSE SHALL CONFORM TO ASTM D2940.
- 2.7 UNSUITABLE MATERIAL: HIGH AND MODERATELY PLASTIC SILTS AND CLAYS (LL>45). MATERIAL CONTAINING REFUSE, FROZEN LUMPS, DEMOLISHED BITUMINOUS MATERIAL, VEGETATIVE MATTER, WOOD, STONES IN EXCESS OF 3 INCHES IN ANY DIMENSION, AND DEBRIS AS DETERMINED BY THE CONSTRUCTION MANAGER. TYPICAL THESE WILL BE SOILS CLASSIFIED BY ASTM AS PT, MH, CH, OH, ML, AND OL.
- 2.8 GEOTEXTILE FABRIC: MIRAFI 500X OR ENGINEERED APPROVED EQUAL.
- 2.9 PLASTIC MARKING TAPE: SHALL BE ACID AND ALKALI RESISTANT POLYETHYLENE FILM SPECIFICALLY MANUFACTURED FOR MARKING AND LOCATING UNDERGROUND UTILITIES, 6 INCHES WIDE WITH A MINIMUM THICKNESS OF 0.004 INCH. TAPE SHALL HAVE MINIMUM STRENGTH OF 1500 PSI IN BOTH DIRECTIONS AND MANUFACTURED WITH INTEGRAL CONDUCTORS, FOIL BACKING OR OTHER MEANS TO ENABLE DETECTION BY A METAL DETECTOR WHEN BURIED UP TO 3 FEET DEEP. THE METALLIC CORE OF THE TAPE SHALL BE ENCASED IN A PROTECTIVE JACKET OR PROVIDED WITH OTHER MEANS TO PROTECT IT FROM CORROSION. TAPE COLOR SHALL BE RED FOR ELECTRIC UTILITIES AND ORANGE FOR TELECOMMUNICATION UTILITIES.

PART 3 – EXECUTION

3.1 GENERAL:

- A. BEFORE STARTING GENERAL SITE PREPARATION ACTIVITIES, INSTALL EROSION AND SEDIMENT CONTROL MEASURES. THE WORK AREA SHALL BE CONSTRUCTED AND MAINTAINED IN SUCH CONDITION THAT IN THE EVENT OF RAIN THE SITE WILL BE DRAINED AT ANY TIME.
 - B. BEFORE ALL SURVEY, LAYOUT, STAKING, AND MARKING, ESTABLISH AND MAINTAIN ALL LINES, GRADES, ELEVATIONS AND BENCHMARKS NEEDED FOR EXECUTION OF THE WORK.
 - C. CLEAR AND GRUB THE AREA WITHIN THE LIMITS OF THE SITE. REMOVE TREES, BRUSH, STUMPS, RUBBISH AND OTHER DEBRIS AND VEGETATION RESTING ON OR PROTRUDING THROUGH THE SURFACE OF THE SITE AREA TO BE CLEARED.
1. REMOVE THE FOLLOWING MATERIALS TO A DEPTH OF NO LESS THAN 12 INCHES BELOW THE ORIGINAL GROUND SURFACE: ROOTS, STUMPS, AND OTHER DEBRIS, BRUSH, AND REFUSE EMBEDDED IN OR PROTRUDING THROUGH THE GROUND SURFACE, RAKE, DISK OR PLOW THE AREA TO A DEPTH OF NO LESS THAN 6 INCHES, AND REMOVE TO A DEPTH OF 12 INCHES ALL ROOTS AND OTHER DEBRIS THEREBY EXPOSED.

- 2. REMOVE TOPSOIL MATERIAL COMPLETELY FROM THE SURFACE UNTIL THE SOIL NO LONGER MEETS THE DEFINITION OF TOPSOIL. AVOID MIXING TOPSOIL WITH SUBSOIL OR OTHER UNDESIRABLE MATERIALS.
- 3. EXCEPT WHERE EXCAVATION TO GREATER DEPTH IS INDICATED, FILL DEPRESSIONS RESULTING FROM CLEARING, GRUBBING AND DEMOLITION WORK COMPLETELY WITH SUITABLE FILL.

- A. REMOVE FROM THE SITE AND DISPOSE IN AN AUTHORIZED LANDFILL ALL DEBRIS RESULTING FROM CLEARING AND GRUBBING OPERATIONS. BURNING WILL NOT BE PERMITTED.
- B. PRIOR TO EXCAVATING, THOROUGHLY EXAMINE THE AREA TO BE EXCAVATED AND/OR TRENCHED TO VERIFY THE LOCATIONS OF FEATURES INDICATED ON THE DRAWINGS AND TO ASCERTAIN THE EXISTENCE AND LOCATION OF ANY STRUCTURE, UNDERGROUND STRUCTURE, OR OTHER ITEM NOT SHOWN THAT MIGHT INTERFERE WITH THE PROPOSED CONSTRUCTION. NOTIFY THE CONSTRUCTION MANAGER OF ANY OBSTRUCTIONS THAT WILL PREVENT ACCOMPLISHMENT OF THE WORK AS INDICATED ON THE DRAWINGS.
- C. SEPARATE AND STOCK PILE ALL EXCAVATED MATERIALS SUITABLE FOR BACKFILL. ALL EXCESS EXCAVATED AND UNSUITABLE MATERIALS SHALL BE DISPOSED OF OFF-SITE IN A LEGAL MANNER.

3.2 BACKFILL:

- A. AS SOON AS PRACTICAL, AFTER COMPLETING CONSTRUCTION OF THE RELATED STRUCTURE, INCLUDING EXPIRATION OF THE SPECIFIED MINIMUM CURING PERIOD FOR CAST-IN-PLACE CONCRETE, BACKFILL THE EXCAVATION WITH APPROVED MATERIAL TO RESTORE THE REQUIRED FINISHED GRADE.
- 1. PRIOR TO PLACING BACKFILL AROUND STRUCTURES, ALL FORMS SHALL BE REMOVED AND THE EXCAVATION CLEANED OF ALL TRASH, DEBRIS, AND UNSUITABLE MATERIALS.
- 2. BACKFILL BY PLACING AND COMPACTING SUITABLE BACKFILL MATERIAL OR SELECT GRANULAR BACKFILL MATERIAL WHEN REQUIRED IN UNIFORM HORIZONTAL LAYERS OF NO GREATER THAN 8-INCHES LOOSE THICKNESS AND COMPACTED. WHERE HAND OPERATED COMPACTORS ARE USED, THE FILL MATERIAL SHALL BE PLACED IN LIFTS NOT TO EXCEED 4 INCHES IN LOOSE DEPTH AND COMPACTED.
- 3. WHENEVER THE DENSITY TESTING INDICATES THAT THE CONTRACTOR HAS NOT OBTAINED THE SPECIFIED DENSITY, THE SUCCEEDING LAYER SHALL NOT BE PLACED UNTIL THE SPECIFICATION REQUIREMENTS ARE MET UNLESS OTHERWISE AUTHORIZED BY THE GEOTECHNICAL ENGINEER. THE CONTRACTOR SHALL TAKE WHATEVER APPROPRIATE ACTION IS NECESSARY, SUCH AS DISKING AND DRYING, ADDING WATER, OR INCREASING THE COMPACTIVE EFFORT TO MEET THE MINIMUM COMPACTION REQUIREMENTS.

- B. THOROUGHLY COMPACT EACH LAYER OF BACKFILL TO A MINIMUM OF 95 PERCENT OF THE MAXIMUM DRY DENSITY AS PROVIDED BY THE STANDARD PROCTOR TEST, ASTM D 698.

3.3 TRENCH EXCAVATION:

- A. UTILITY TRENCHES SHALL BE EXCAVATED TO THE LINES AND GRADES SHOWN ON THE DRAWINGS OR AS DIRECTED BY THE GENERAL CONTRACTOR. PROVIDE SHORING, SHEETING AND BRACING AS REQUIRED TO PREVENT CAVING OR SLOUGHING OF THE TRENCH WALLS.
- B. EXTEND THE TRENCH WIDTH A MINIMUM OF 6 INCHES BEYOND THE OUTSIDE EDGE OF THE OUTERMOST CONDUIT.
- C. WHEN SOFT YIELDING, OR OTHERWISE UNSTABLE SOIL CONDITIONS ARE ENCOUNTERED, BACKFILL AT THE REQUIRED TRENCH TO A DEPTH OF NO LESS THAN 12 INCHES BELOW THE REQUIRED ELEVATION AND BACKFILL WITH GRANULAR BEDDING MATERIAL.

3.4 TRENCH BACKFILL:

- A. PROVIDE GRANULAR BEDDING MATERIAL IN ACCORDANCE WITH THE DRAWINGS AND THE UTILITY REQUIREMENTS.
- B. NOTIFY THE GENERAL CONTRACTOR 24 HOURS IN ADVANCE OF BACKFILLING.
- C. CONDUCT UTILITY CHECK TESTS BEFORE BACKFILLING. BACKFILL AND COMPACT TRENCH BEFORE ACCEPTANCE TESTING.
- D. PLACE GRANULAR TRENCH BACKFILL UNIFORMLY ON BOTH SIDES OF THE CONDUITS IN 6-INCH UNCOMPACTED LIFTS UNTIL 12 INCHES OVER THE CONDUITS. SOLIDLY RAM AND TAMP BACKFILL INTO SPACE AROUND CONDUITS.
- E. PROTECT CONDUIT FROM LATERAL MOVEMENT, IMPACT DAMAGE, OR UNBALANCED LOADING.
- F. ABOVE THE CONDUIT EMBEDMENT ZONE, PLACE AND COMPACT SATISFACTORY BACKFILL MATERIAL IN 8-INCH MAXIMUM LOOSE THICKNESS LIFTS TO RESTORE THE REQUIRED FINISHED SURFACE GRADE.
- G. COMPACT FINAL TRENCH BACKFILL TO A DENSITY EQUAL TO OR GREATER THAN THAT OF THE EXISTING UNDISTURBED MATERIAL IMMEDIATELY ADJACENT TO THE TRENCH BUT NO LESS THAN A MINIMUM OF 95 PERCENT OF THE MAXIMUM DRY DENSITY AS PROVIDED BY THE STANDARD PROCTOR TEST, ASTM D 698.

3.5 AGGREGATE ACCESS ROAD:

- A. CLEAR, GRUB, STRIP AND EXCAVATE FOR THE ACCESS ROAD TO THE LINES AND GRADES INDICATED ON THE DRAWINGS. SCARIFY TO A DEPTH OF 6 INCHES AND PROOF-ROLL. ALL HOLES, RUTS, SOFT PLACES AND OTHER DEFECTS SHALL BE CORRECTED.
- B. THE ENTIRE SUBGRADE SHALL BE COMPACTED TO NOT LESS THAN 95 PERCENT OF THE MAXIMUM DRY DENSITY AS PROVIDED BY THE MODIFIED PROCTOR TEST, ASTM D 1557.
- C. AFTER PREPARATION OF THE SUBGRADE IS COMPLETE THE GEOTEXTILE FABRIC (MIRAFI 500X) SHALL BE INSTALLED TO THE LIMITS INDICATED ON THE DRAWINGS BY ROLLING THE FABRIC OUT LONGITUDINALLY ALONG THE ROADWAY. THE FABRIC SHALL NOT BE DRAGGED ACROSS THE SUBGRADE. PLACE THE ENTIRE ROLL IN A SINGLE OPERATION, ROLLING OUT AS SMOOTHLY AS POSSIBLE.

- 1. OVERLAPS PARALLEL TO THE ROADWAY WILL BE PERMITTED AT THE CENTERLINE AND AT LOCATIONS BEYOND THE ROADWAY SURFACE WIDTH (I.E. WITHIN THE SHOULDER WIDTH) ONLY. NO LONGITUDINAL OVERLAPS SHALL BE LOCATED BETWEEN THE CENTERLINE AND THE SHOULDER. PARALLEL OVERLAPS SHALL BE A MINIMUM OF 3 FEET WIDE.
- 2. TRANSVERSE (PERPENDICULAR TO THE ROADWAY) OVERLAPS AT THE END OF A ROLL SHALL OVERLAP IN THE DIRECTION OF THE AGGREGATE PLACEMENT (PREVIOUS ROLL ON TOP) AND SHALL HAVE A MINIMUM LENGTH OF 3 FEET.
- 3. ALL OVERLAPS SHALL BE PINNED WITH STAPLES OR NAILS A MINIMUM OF 10 INCHES LONG TO INSURE POSITIONING DURING PLACEMENT OF AGGREGATE. PIN LONGITUDINAL SEAMS AT 25 FOOT CENTERS AND TRANSVERSE SEAMS EVERY 5 FEET.

- D. THE AGGREGATE BASE AND SURFACE COURSES SHALL BE CONSTRUCTED IN LAYERS NOT MORE THAN 4 INCH (COMPACTED) THICKNESS. AGGREGATE TO BE PLACED ON GEOTEXTILE FABRIC SHALL BE END-DUMPED ON THE FABRIC FROM THE FREE END OF THE FABRIC OR OVER PREVIOUSLY PLACED AGGREGATE. THE FIRST LIFT SHALL BE BLADED DOWN TO A THICKNESS OF 8 INCHES PRIOR TO COMPACTION. AT NO TIME SHALL EQUIPMENT, EITHER TRANSPORTING THE AGGREGATE OR GRADING THE AGGREGATE, BE PERMITTED ON THE ROADWAY WITH LESS THAN 4 INCHES OF MATERIAL COVERING THE FABRIC.
- E. THE AGGREGATE SHALL BE IMMEDIATELY COMPACTED TO NOT LESS THAN 95 PERCENT OF THE MAXIMUM DRY DENSITY AS PROVIDED BY THE MODIFIED PROCTOR TEST, ASTM D 1557 WITH A TAMPING ROLLER, OR WITH A PNEUMATIC-TIRED ROLLER, OR WITH A VIBRATORY MACHINE OR ANY COMBINATION OF THE ABOVE. THE TOP LAYER SHALL BE GIVEN A FINAL ROLLING WITH A THREE-WHEEL OR TANDEM ROLLER.

3.6 FINISH GRADING:

- A. PERFORM ALL GRADING TO PROVIDE POSITIVE DRAINAGE AWAY FROM STRUCTURES AND SMOOTH, EVEN SURFACE DRAINAGE OF THE ENTIRE AREA WITHIN THE LIMITS OF CONSTRUCTION. GRADING SHALL BE COMPATIBLE WITH ALL SURROUNDING TOPOGRAPHY AND STRUCTURES.
- B. UTILIZE SATISFACTORY FILL MATERIAL RESULTING FROM THE EXCAVATION WORK IN THE CONSTRUCTION OF FILLS, EMBANKMENTS AND FOR REPLACEMENT OF REMOVED UNSUITABLE MATERIALS.
- C. ACHIEVE FINISHED GRADE BY PLACING A MINIMUM OF 4 INCHES OF 1/2" – 3/4" CRUSHED STONE ON TOP SOIL STABILIZER FABRIC.
- D. REPAIR ALL ACCESS ROADS AND SURROUNDING AREAS USED DURING THE COURSE OF THIS WORK TO THEIR ORIGINAL CONDITION.

3.7 ASPHALT PAVING ROAD:

- A. CHAPTER 630 – CALIFORNIA DEPARTMENT OF TRANSPORTATION FLEXIBLE PAVEMENT
- B. DESIGN GUIDE AND STANDARDS FOR ROADWAY REHABILITATION PROJECTS (DIB 79-03)



5001 EXECUTIVE PKWY
SAN RAMON, CA 94583



575 LENNON LANE, SUITE 125
WALNUT CREEK, CA 94598



26455 RANCHO PARKWAY SOUTH
LAKE FOREST, CALIFORNIA 92630
JOB NUMBER 469-001

3	06/19/19	CHANGE TO MONOPOLE
2	05/16/19	90% CONSTRUCTION DRAWINGS
1	04/26/19	90% CONSTRUCTION DRAWINGS
0	04/17/19	90% CONSTRUCTION DRAWINGS
REV	DATE	DESCRIPTION

IT IS A VIOLATION OF LAW FOR ANY PERSON, UNLESS THEY ARE ACTING UNDER THE DIRECTION OF A LICENSED PROFESSIONAL ENGINEER, TO ALTER THIS DOCUMENT.

CCL04830
CUERVO HOLDINGS
51500 PINE CANYON
KING CITY, CA 93930
TOWER/CWIC

SHEET TITLE
GENERAL NOTES

SHEET NUMBER
GN-2

ELECTRICAL NOTES

PART 1 – GENERAL

1.1 GENERAL CONDITIONS:

- A. CONTRACTOR SHALL INSPECT THE EXISTING SITE CONDITIONS PRIOR TO SUBMITTING BID. ANY QUESTIONS ARISING DURING THE BID PERIOD IN REGARDS TO THE SUBCONTRACTORS FUNCTIONS, THE SCOPE OF WORK, OR ANY OTHER ISSUE RELATED TO THIS PROJECT SHALL BE BROUGHT UP DURING THE BID PERIOD WITH THE PROJECT MANAGER FOR CLARIFICATION, NOT AFTER THE CONTRACT HAS BEEN AWARDED.
- B. THE SUBCONTRACTOR SHALL OBTAIN PERMITS, LICENSES, MAKE ALL DEPOSITS, AND PAY ALL FEES REQUIRED FOR THE CONSTRUCTION PERFORMANCE FOR THE WORK UNDER THIS SECTION.
- C. DRAWINGS SHOW THE GENERAL ARRANGEMENT OF ALL SYSTEMS AND COMPONENTS COVERED UNDER THIS SECTION. THE SUBCONTRACTOR SHALL VERIFY ALL DIMENSIONS. DRAWING SHALL NOT BE SCALED TO DETERMINE DIMENSIONS.

1.2 LAWS, REGULATIONS, ORDINANCES, STATUTES AND CODES.

- A. ALL WORK SHALL BE INSTALLED IN ACCORDANCE WITH THE LATEST EDITION OF THE NATIONAL ELECTRICAL CODE, AND ALL APPLICABLE LOCAL LAWS, REGULATIONS, ORDINANCES, STATUTES AND CODES. CONDUIT BENDS SHALL BE THE RADIUS BEND FOR THE TRADE SIZE OF CONDUIT IN COMPLIANCE WITH THE LATEST EDITIONS OF NEC.

1.3 REFERENCES:

- A. THE PUBLICATIONS LISTED BELOW ARE PART OF THIS SPECIFICATION. EACH PUBLICATION SHALL BE THE LATEST REVISION AND ADDENDUM IN EFFECT ON THE DATE. THIS SPECIFICATION IS ISSUED FOR CONSTRUCTION UNLESS OTHERWISE NOTED. EXCEPT AS MODIFIED BY THE REQUIREMENT SPECIFIED HEREIN OR THE DETAILS OF THE DRAWINGS, WORK INCLUDED IN THIS SPECIFICATION SHALL CONFORM TO THE APPLICABLE PROVISION OF THESE PUBLICATIONS.

- 1. ANSI/IEEE (AMERICAN NATIONAL STANDARDS INSTITUTE)
- 2. ASTM (AMERICAN SOCIETY FOR TESTING AND MATERIALS)
- 3. ICE (INSULATED CABLE ENGINEERS ASSOCIATION)
- 4. NEMA (NATIONAL ELECTRICAL MANUFACTURER'S ASSOCIATION)
- 5. NFPA (NATIONAL FIRE PROTECTION ASSOCIATION)
- 6. OSHA (OCCUPATIONAL SAFETY AND HEALTH ADMINISTRATION)
- 7. UL (UNDERWRITERS LABORATORIES, INC.)
- 8. AT&T GROUNDING AND BONDING STANDARDS TP-76416

1.4 SCOPE OF WORK:

- A. WORK UNDER THIS SECTION SHALL CONSIST OF FURNISHING ALL LABOR, MATERIAL, AND ASSOCIATED SERVICES REQUIRED TO COMPLETE REQUIRED CONSTRUCTION AND BE OPERATIONAL.
- B. ALL ELECTRICAL EQUIPMENT UNDER THIS CONTRACT SHALL BE PROPERLY TESTED, ADJUSTED, AND ALIGNED BY THE SUBCONTRACTOR
- C. THE SUBCONTRACTOR SHALL BE RESPONSIBLE FOR ALL EXCAVATING, DRAINING, TRENCHES, BACKFILLING, AND REMOVAL OF EXCESS DIRT.
- D. THE SUBCONTRACTOR SHALL FURNISH TO THE OWNER WITH CERTIFICATES OF A FINAL INSPECTION AND APPROVAL FROM THE INSPECTION AUTHORITIES HAVING JURISDICTION.
- E. THE SUBCONTRACTOR SHALL PREPARE A COMPLETE SET OF AS-BUILT DRAWINGS, DOCUMENT ALL WIRING EQUIPMENT CONDITIONS, AND CHANGES WHILE COMPLETING THIS CONTRACT. THE AS-BUILT DRAWINGS SHALL BE SUBMITTED AT COMPLETION OF THE PROJECT.

PART 2 – PRODUCTS

2.1 GENERAL:

- A. ALL MATERIALS AND EQUIPMENT SHALL BE UL LISTED, NEW, AND FREE FROM DEFECTS.
- B. ALL ITEMS OF MATERIALS AND EQUIPMENT SHALL BE ACCEPTABLE TO THE AUTHORITY HAVING JURISDICTION AS SUITABLE FOR THE USE INTENDED.
- C. ALL EQUIPMENT SHALL BEAR THE UNDERWRITERS LABORATORIES LABEL OF APPROVAL, AND SHALL CONFORM TO REQUIREMENT OF THE NATIONAL ELECTRICAL CODE.
- D. ALL OVERCURRENT DEVICES SHALL HAVE AN INTERRUPTING CURRENT RATING EQUAL TO OR GREATER THAN THE SHORT CIRCUIT CURRENT TO WHICH THEY ARE SUBJECTED, 10,000 AIC MINIMUM. VERIFY AVAILABLE SHORT CIRCUIT CURRENT DOES NOT EXCEED THE RATING OF ELECTRICAL EQUIPMENT.

2.2 MATERIALS AND EQUIPMENT:

A. CONDUIT:

- 1. RIGID METAL CONDUIT (RMC) SHALL BE HOT-DIPPED GALVANIZED INSIDE AND OUTSIDE INCLUDING ENDS AND THREADS AND ENAMELED OR LACQUERED INSIDE IN ADDITION TO GALVANIZING.
- 2. LIQUDTIGHT FLEXIBLE METAL CONDUIT SHALL BE UL LISTED.
- 3. CONDUIT CLAMPS, STRAPS AND SUPPORTS SHALL BE STEEL OR MALLEABLE IRON. ALL FITTINGS SHALL BE COMPRESSION AND CONCRETE TIGHT TYPE. GROUNDING BUSHINGS WITH INSULATED THROATS SHALL BE INSTALLED ON ALL CONDUIT TERMINATIONS.
- 4. NONMETALLIC CONDUIT AND FITTINGS SHALL BE SCHEDULE 40 PVC. INSTALL USING SOLVENT-CEMENT-TYPE JOINTS AS RECOMMENDED BY THE MANUFACTURER.

B. CONDUCTORS AND CABLE:

- 1. CONDUCTORS AND CABLE SHALL BE FLAME-RETARDANT, MOISTURE AND HEAT RESISTANT THERMOPLASTIC, SINGLE CONDUCTOR, COPPER, TYPE THHN/THWN-2, 600 VOLT, SIZE AS INDICATED, #12 AWG SHALL BE THE MINIMUM SIZE CONDUCTOR USED.
- 2. #10 AWG AND SMALLER CONDUCTOR SHALL BE SOLID OR STRANDED AND #8 AWG AND LARGER CONDUCTORS SHALL BE STRANDED.
- 3. SOLDERLESS, COMPRESSION-TYPE CONNECTORS SHALL BE USED FOR TERMINATION OF ALL STRANDED CONDUCTORS.
- 4. STRAIN-RELIEF SUPPORTS GRIPS SHALL BE HUBBELL KELLEMS OR APPROVED EQUAL. CABLES SHALL BE SUPPORTED IN ACCORDANCE WITH THE NEC AND CABLE MANUFACTURER'S RECOMMENDATIONS.
- 5. ALL CONDUCTORS SHALL BE TAGGED AT BOTH ENDS OF THE CONDUCTOR, AT ALL PULL BOXES, J-BOXES, EQUIPMENT AND CABINETS AND SHALL BE IDENTIFIED WITH APPROVED PLASTIC TAGS (ACTION CRAFT, BRADY, OR APPROVED EQUAL).

C. DISCONNECT SWITCHES:

- 1. DISCONNECT SWITCHES SHALL BE HEAVY DUTY, DEAD-FRONT, QUICK-MAKE, QUICK-BREAK, EXTERNALLY OPERABLE, HANDLE LOCKABLE AND INTERLOCK WITH COVER IN CLOSED POSITION, RATING AS INDICATED, UL LABELED FURNISHED IN NEMA 3R ENCLOSURE, SQUARE-D OR ENGINEERED APPROVED EQUAL.

D. CHEMICAL ELECTROLYTIC GROUNDING SYSTEM:

- 1. INSTALL CHEMICAL GROUNDING AS REQUIRED. THE SYSTEM SHALL BE ELECTROLYTIC MAINTENANCE FREE ELECTRODE CONSISTING OF RODS WITH A MINIMUM 2 AWG CU EXOTHERMICALLY WELDED PIGTAIL, PROTECTIVE BOXES, AND BACKFILL MATERIAL. MANUFACTURER SHALL BE LYNCOLE XIT GROUNDING ROD TYPES K2-(*)CS OR K2L-(*)CS (*) LENGTH AS REQUIRED.
- 2. GROUND ACCESS BOX SHALL BE A POLYPLASTIC BOX FOR NON-TRAFFIC APPLICATIONS, INCLUDING BOLT DOWN FLUSH COVER WITH "BREATHER" HOLES, XIT MODEL #XB-22. ALL DISCONNECT SWITCHES AND CONTROLLING DEVICES SHALL BE PROVIDED WITH ENGRAVED LAMICOID NAMEPLATES INDICATING EQUIPMENT CONTROLLED, BRANCH CIRCUITS ID NUMBERING, AND THE ELECTRICAL POWER SOURCE.
- 3. BACKFILL MATERIAL SHALL BE LYCONITE AND LYNCOLE GROUNDING GRAVEL.

E. SYSTEM GROUNDING:

- 1. ALL GROUNDING COMPONENTS SHALL BE TINNED AND GROUNDING CONDUCTOR SHALL BE 2 AWG BARE, SOLID, TINNED, COPPER. ABOVE GRADE GROUNDING CONDUCTORS SHALL BE INSULATED WHERE NOTED.
- 2. GROUNDING BUSES SHALL BE BARE, TINNED, ANNEALED COPPER BARS OF RECTANGULAR CROSS SECTION. STANDARD BUS BARS MGB, SHALL BE FURNISHED AND INSTALLED BY THE SUBCONTRACTOR. THEY SHALL NOT BE FABRICATED OR MODIFIED IN THE FIELD. ALL GROUNDING BUSES SHALL BE IDENTIFIED WITH MINIMUM 3/4" LETTERS BY WAY OF STENCILING OR DESIGNATION PLATE.
- 3. CONNECTORS SHALL BE HIGH-CONDUCTIVITY, HEAVY DUTY, LISTED AND LABELED AS GROUNDING CONNECTORS FOR THE MATERIALS USED. USE TWO-HOLE COMPRESSION LUGS WITH HEAT SHRINK FOR MECHANICAL CONNECTIONS. INTERIOR CONNECTIONS USE TWO-HOLE COMPRESSION LUGS WITH INSPECTION WINDOW AND CLEAR HEAT SHRINK.
- 4. EXOTHERMIC WELDED CONNECTIONS SHALL BE PROVIDED IN KIT FORM AND SELECTED FOR THE SPECIFIC TYPES, SIZES, AND COMBINATIONS OF CONDUCTORS AND OTHER ITEMS TO BE CONNECTED.
- 5. GROUND RODS SHALL BE COPPER-CLAD STEEL WITH HIGH-STRENGTH STEEL CORE AND ELECTROLYTIC-GRADE COPPER OUTER SHEATH, MOLTEN WELDED TO CORE, 5/8"x10"-0". ALL GROUNDING RODS SHALL BE INSTALLED WITH INSPECTION SLEEVES.
- 6. INSTALL AN EQUIPMENT GROUNDING CONDUCTOR IN ALL CONDUITS IN COMPLIANCE WITH THE AT&T SPECIFICATIONS AND NEC. THE EQUIPMENT GROUNDING CONDUCTORS SHALL BE BONDED AT ALL JUNCTION BOXES, PULLBOXES, DISCONNECT SWITCHES, STARTERS, AND EQUIPMENT CABINETS.

F. OTHER MATERIALS:

- 1. THE SUBCONTRACTOR SHALL PROVIDE OTHER MATERIALS, THOUGH NOT SPECIFICALLY DESCRIBED, WHICH ARE REQUIRED FOR A COMPLETELY OPERATIONAL SYSTEM AND PROPER INSTALLATION OF THE WORK.
- 2. PROVIDE PULL BOXES AND JUNCTION BOXES WHERE SHOWN OR REQUIRED BY NEC.

G. PANELS AND LOAD CENTERS:

- 1. ALL PANEL DIRECTORIES SHALL BE TYPEWRITTEN.

PART 3 – EXECUTION

3.1 GENERAL:

- A. ALL MATERIAL AND EQUIPMENT SHALL BE INSTALLED IN STRICT ACCORDANCE WITH THE MANUFACTURER'S RECOMMENDATIONS.
- B. EQUIPMENT SHALL BE TIGHTLY COVERED AND PROTECTED AGAINST DIRT OR WATER, AND AGAINST CHEMICAL OR MECHANICAL INJURY DURING INSTALLATION AND CONSTRUCTION PERIODS.

3.2 LABOR AND WORKMANSHIP:

- A. ALL LABOR FOR THE INSTALLATION OF MATERIALS AND EQUIPMENT FURNISHED FOR THE ELECTRICAL SYSTEM SHALL BE INSTALLED BY EXPERIENCED WIREMEN, IN A NEAT AND WORKMAN-LIKE MANNER.
- B. ALL ELECTRICAL EQUIPMENT SHALL BE ADJUSTED, ALIGNED AND TESTED BY THE SUBCONTRACTOR AS REQUIRED TO PRODUCE THE INTENDED PERFORMANCE.
- C. UPON COMPLETION OF WORK, THE SUBCONTRACTOR SHALL THOROUGHLY CLEAN ALL EXPOSED EQUIPMENT, REMOVE ALL LABELS AND ANY DEBRIS, CRATING OR CARTONS AND LEAVE THE INSTALLATION FINISHED AND READY FOR OPERATION.

3.3 COORDINATION:

- A. THE SUBCONTRACTOR SHALL COORDINATE THE INSTALLATION OF ELECTRICAL ITEMS WITH THE OWNER-FURNISHED EQUIPMENT DELIVERY SCHEDULE TO PREVENT UNNECESSARY DELAYS IN THE TOTAL WORK.

3.4 INSTALLATION:

A. CONDUIT:

- 1. ALL ELECTRICAL WIRING SHALL BE INSTALLED IN CONDUIT AS SPECIFIED. NO CONDUIT OR TUBING OF LESS THAN 3/4 INCH TRADE SIZE.
- 2. PROVIDE RIGID PVC SCHEDULE 80 CONDUITS FOR ALL RISERS, RMC OTHERWISE NOTED. EMT MAY BE INSTALLED FOR EXTERIOR CONDUITS WHERE NOT SUBJECT TO PHYSICAL DAMAGE.
- 3. INSTALL SCH. 40 PVC CONDUIT WITH A MINIMUM COVER OF 24" UNDER ROADWAYS, PARKING LOTS, STREETS, AND ALLEYS. CONDUIT SHALL HAVE A MINIMUM COVER OF 18" IN ALL OTHER NON-TRAFFIC APPLICATIONS (REFER TO 2008 NEC, TABLE 300.5).
- 4. USE GALVANIZED FLEXIBLE STEEL CONDUIT WHERE DIRECT CONNECTION TO EQUIPMENT WITH MOVEMENT, VIBRATION, OR FOR EASE OF MAINTENANCE. USE LIQUID TIGHT, FLEXIBLE METAL CONDUIT FOR OUTDOOR APPLICATIONS. INSTALL GALVANIZED FLEXIBLE STEEL CONDUIT AT ALL POINTS OF CONNECTION TO EQUIPMENT MOUNTED ON SUPPORT TO ALLOW FOR EXPANSION AND CONTRACTION.
- 5. A RUN OF CONDUIT BETWEEN BOXES OR EQUIPMENT SHALL NOT CONTAIN MORE THAN THE EQUIVALENT OF THREE QUARTER-BENDS. CONDUIT BEND SHALL BE MADE WITH THE UL LISTED BENDER OR FACTORY 90 DEGREE ELBOWS MAY BE USED.
- 6. FIELD FABRICATED CONDUITS SHALL BE CUT SQUARE WITH A CONDUIT CUTTING TOOL AND REAMED TO PROVIDE A SMOOTH INSIDE SURFACE.
- 7. PROVIDE INSULATED GROUNDING BUSHING FOR ALL CONDUITS.
- 8. SUBCONTRACTOR IS RESPONSIBLE FOR PROTECTING ALL CONDUITS DURING CONSTRUCTION. TEMPORARY OPENINGS IN THE CONDUIT SYSTEM SHALL BE PLUGGED OR CAPPED TO PREVENT ENTRANCE OF MOISTURE OR FOREIGN MATTER. SUBCONTRACTOR SHALL REPLACE ANY CONDUITS CONTAINING FOREIGN MATERIALS THAT CANNOT BE REMOVED.
- 9. ALL CONDUITS SHALL BE SWABBED CLEAN BY PULLING AN APPROPRIATE SIZE MANDREL THROUGH THE CONDUIT BEFORE INSTALLATION OF CONDUCTORS OR CABLES. CONDUIT SHALL BE FREE OF DIRT AND DEBRIS.
- 10. INSTALL PULL STRINGS IN ALL CLEAN EMPTY CONDUITS. IDENTIFY PULL STRINGS AT EACH END.
- 11. INSTALL 2" HIGHLY VISIBLE AND DETECTABLE TAPE 12" ABOVE ALL UNDERGROUND CONDUITS AND CONDUCTORS.
- 12. CONDUITS SHALL BE INSTALLED IN SUCH A MANNER AS TO INSURE AGAINST COLLECTION OF TRAPPED CONDENSATION.
- 13. PROVIDE CORE DRILLING AS NECESSARY FOR PENETRATIONS TO ALLOW FOR RACEWAYS AND CABLES TO BE ROUTED THROUGH THE BUILDING. DO NOT PENETRATE STRUCTURAL MEMBERS. SLEEVES AND/OR PENETRATIONS IN FIRE RATED CONSTRUCTION SHALL BE EFFECTIVELY SEALED WITH FIRE RATED MATERIAL WHICH SHALL MAINTAIN THE FIRE RATING OF THE WALL OR STRUCTURE. FIRE STOPS AT FLOOR PENETRATIONS SHALL PREVENT PASSAGE OF WATER, SMOKE, FIRE, AND FUMES. ALL MATERIAL SHALL BE UL APPROVED FOR THIS PURPOSE.

B. CONDUCTORS AND CABLE:

- 1. ALL POWER WIRING SHALL BE COLOR CODED AS FOLLOWS:

DESCRIPTION	208/240/120 VOLT SYSTEMS
PHASE A	BLACK
PHASE B	RED
PHASE C	BLUE
NEUTRAL	WHITE
GROUNDING	GREEN

- 2. SPLICES SHALL BE MADE ONLY AT OUTLETS, JUNCTION BOXES, OR ACCESSIBLE RACEWAY CONDULETS APPROVED FOR THIS PURPOSE.
- 3. PULLING LUBRICANTS SHALL BE UL APPROVED. SUBCONTRACTOR SHALL USE NYLON OR HEMP ROPE FOR PULLING CONDUCTOR OR CABLES INTO THE CONDUIT.
- 4. CABLES SHALL BE NEATLY TRAINED, WITHOUT INTERLACING, AND BE OF SUFFICIENT LENGTH IN ALL BOXES & EQUIPMENT TO PERMIT MAKING A NEAT ARRANGEMENT. CABLES SHALL BE SECURED IN A MANNER TO AVOID TENSION ON CONDUCTORS OR TERMINALS. CONDUCTORS SHALL BE PROTECTED FROM MECHANICAL INJURY AND MOISTURE. SHARP BENDS OVER CONDUIT BUSHINGS ARE PROHIBITED. DAMAGED CABLES SHALL BE REMOVED AND REPLACED AT THE SUBCONTRACTOR'S EXPENSE.

C. DISCONNECT SWITCHES:

- 1. INSTALL DISCONNECT SWITCHES LEVEL AND PLUMB. CONNECT TO WIRING SYSTEM AND GROUNDING SYSTEM AS INDICATED.

D. GROUNDING:

- 1. ALL METALLIC PARTS OF ELECTRICAL EQUIPMENT WHICH DO NOT CARRY CURRENT SHALL BE GROUNDED IN ACCORDANCE WITH THE REQUIREMENTS OF THE BUILDING MANUFACTURER, AT&T GROUNDING AND BONDING STANDARDS TP-76416, ND-00135, AND THE NATIONAL ELECTRICAL CODE.
- 2. PROVIDE ELECTRICAL GROUNDING AND BONDING SYSTEM INDICATED WITH ASSEMBLY OF MATERIALS, INCLUDING GROUNDING ELECTRODES, BONDING JUMPERS AND ADDITIONAL ACCESSORIES AS REQUIRED FOR A COMPLETE INSTALLATION.
- 3. ALL GROUNDING CONDUCTORS SHALL PROVIDE A STRAIGHT DOWNWARD PATH TO GROUND WITH GRADUAL BEND AS REQUIRED. GROUNDING CONDUCTORS SHALL NOT BE LOOPED OR SHARPLY BENT. ROUTE GROUNDING CONNECTIONS AND CONDUCTORS TO GROUND IN THE SHORTEST AND STRAIGHTEST PATHS POSSIBLE TO MINIMIZE TRANSIENT VOLTAGE RISES.
- 4. BUILDINGS AND/OR NEW TOWERS GREATER THAN 75 FEET IN HEIGHT AND WHERE THE MAIN GROUNDING CONDUCTORS ARE REQUIRED TO BE ROUTED TO GRADE, THE SUBCONTRACTOR SHALL ROUTE TWO GROUNDING CONDUCTORS FROM THE ROOFTOP, TOWERS, AND WATER TOWERS GROUNDING RING, TO THE EXISTING GROUNDING SYSTEM, THE GROUNDING CONDUCTORS SHALL NOT BE SMALLER THAN 2/0 AWG COPPER. ROOFTOP GROUNDING RING SHALL BE BONDED TO THE EXISTING GROUNDING SYSTEM, THE BUILDING STEEL COLUMNS, LIGHTNING PROTECTION SYSTEM, AND BUILDING MAIN WATER LINE (FERROUS OR NONFERROUS METAL PIPING ONLY). SEE STANDARD 6.3.2.2.
- 5. TIGHTEN GROUNDING AND BONDING CONNECTORS, INCLUDING SCREWS AND BOLTS, IN ACCORDANCE WITH MANUFACTURER'S PUBLISHED TORQUE TIGHTENING VALUES FOR CONNECTORS AND BOLTS. WHERE MANUFACTURER'S TORQUING REQUIREMENTS ARE NOT AVAILABLE, TIGHTEN CONNECTIONS TO COMPLY WITH TIGHTENING TORQUE VALUES SPECIFIED IN UL TO ASSURE PERMANENT AND EFFECTIVE GROUNDING.
- 6. SUBCONTRACTOR SHALL VERIFY THE LOCATIONS OF GROUNDING TIE-IN-POINTS TO THE EXISTING GROUNDING SYSTEM. ALL UNDERGROUND GROUNDING CONNECTIONS SHALL BE MADE BY THE EXOTHERMIC WELD PROCESS AND INSTALLED IN ACCORDANCE WITH THE MANUFACTURER'S INSTRUCTIONS.
- 7. ALL GROUNDING CONNECTIONS SHALL BE INSPECTED FOR TIGHTNESS. EXOTHERMIC WELDED CONNECTIONS SHALL BE APPROVED BY THE INSPECTOR HAVING JURISDICTION BEFORE BEING PERMANENTLY CONCEALED.
- 8. APPLY CORROSION-RESISTANCE FINISH TO FIELD CONNECTIONS AND PLACES WHERE FACTORY APPLIED PROTECTIVE COATINGS HAVE BEEN DESTROYED. USE KOPR-SHIELD ANTI-OXIDATION COMPOUND ON ALL COMPRESSION GROUNDING CONNECTIONS.
- 9. A SEPARATE, CONTINUOUS, INSULATED EQUIPMENT GROUNDING CONDUCTOR SHALL BE INSTALLED IN ALL FEEDER AND BRANCH CIRCUITS.
- 10. BOND ALL INSULATED GROUNDING BUSHINGS WITH A BARE 6 AWG GROUNDING CONDUCTOR TO A GROUND BUS.
- 11. DIRECT BURIED GROUNDING CONDUCTORS SHALL BE INSTALLED AT A NOMINAL DEPTH OF 36" MINIMUM BELOW GRADE, OR 6" BELOW THE FROST LINE, USE THE GREATER OF THE TWO DISTANCES.
- 12. ALL GROUNDING CONDUCTORS EMBEDDED IN OR PENETRATING CONCRETE SHALL BE INSTALLED IN SCHEDULE 40 PVC CONDUIT.
- 13. THE INSTALLATION OF CHEMICAL ELECTROLYTIC GROUNDING SYSTEM IN STRICT ACCORDANCE WITH MANUFACTURER'S INSTRUCTIONS. REMOVE SEALING TAPE FROM LEACHING AND BREATHER HOLES. INSTALL PROTECTIVE BOX FLUSH WITH GRADE.
- 14. DRIVE GROUND RODS UNTIL TOPS ARE A MINIMUM DISTANCE OF 36" DEPTH OR 6" BELOW FROST LINE, USING THE GREATER OF THE TWO DISTANCES.
- 15. IF COAX ON THE ICE BRIDGE IS MORE THAN 6 FT. FROM THE GROUNDING BAR AT THE BASE OF THE TOWER, A SECOND GROUNDING BAR WILL BE NEEDED AT THE END OF THE ICE BRIDGE, TO GROUND THE COAX CABLE GROUNDING KITS AND IN-LINE ARRESTERS.
- 16. SUBCONTRACTOR SHALL REPAIR, AND/OR REPLACE, EXISTING GROUNDING SYSTEM COMPONENTS DAMAGED DURING CONSTRUCTION AT THE SUBCONTRACTORS EXPENSE.

3.5 ACCEPTANCE TESTING:

- A. CERTIFIED PERSONNEL USING CERTIFIED EQUIPMENT SHALL PERFORM REQUIRED TESTS AND SUBMIT WRITTEN TEST REPORTS UPON COMPLETION.
- B. WHEN MATERIAL AND/OR WORKMANSHIP IS FOUND NOT TO COMPLY WITH THE SPECIFIED REQUIREMENTS, THE NONCOMPLYING ITEMS SHALL BE REMOVED FROM THE PROJECT SITE AND REPLACED WITH ITEMS COMPLYING WITH THE SPECIFIED REQUIREMENTS PROMPTLY AFTER RECEIPT OF NOTICE FOR NON-COMPLIANCE.
- C. TEST PROCEDURES:
 - 1. ALL FEEDERS SHALL HAVE INSULATION TESTED AFTER INSTALLATION, BEFORE CONNECTION TO DEVICES. THE CONDUCTORS SHALL TEST FREE FROM SHORT CIRCUITS AND GROUNDS. TESTING SHALL BE FOR ONE MINUTE USING 1000V DC. PROVIDE WRITTEN DOCUMENTATION FOR ALL TEST RESULTS.
 - 2. PRIOR TO ENERGIZING CIRCUITRY, TEST WIRING DEVICES FOR ELECTRICAL CONTINUITY AND PROPER POLARITY CONNECTIONS.
 - 3. MEASURE AND RECORD VOLTAGES BETWEEN PHASES AND BETWEEN PHASE CONDUCTORS AND NEUTRALS. SUBMIT A REPORT OF MAXIMUM AND MINIMUM VOLTAGES
 - 4. PERFORM GROUNDING TEST TO MEASURE GROUNDING RESISTANCE OF GROUNDING SYSTEM USING THE IEEE STANDARD 3-POINT "FALL-OF-POTENTIAL" METHOD. PROVIDE PLOTTED TEST VALUES AND LOCATION SKETCH. NOTIFY THE ENGINEER IMMEDIATELY IF MEASURED VALUE IS OVER 5 OHMS.



5001 EXECUTIVE PKWY
SAN RAMON, CA 94583



575 LENNON LANE, SUITE 125
WALNUT CREEK, CA 94598

INFINIGY
ENGINEERING, LLP

26455 RANCHO PARKWAY SOUTH
LAKE FOREST, CALIFORNIA 92630

JOB NUMBER 469-001

REV	DATE	DESCRIPTION
3	06/19/19	CHANGE TO MONOPOLE
2	05/16/19	90% CONSTRUCTION DRAWINGS
1	04/26/19	90% CONSTRUCTION DRAWINGS
0	04/17/19	90% CONSTRUCTION DRAWINGS

IT IS A VIOLATION OF LAW FOR ANY PERSON, UNLESS THEY ARE ACTING UNDER THE DIRECTION OF A LICENSED PROFESSIONAL ENGINEER, TO ALTER THIS DOCUMENT.

CCL04830
CUERVO HOLDINGS
51500 PINE CANYON
KING CITY, CA 93930
TOWER/CWIC

SHEET TITLE
GENERAL NOTES

SHEET NUMBER
GN-3



MARATHON™ Front Terminal Specifications

Model Number	Voltage	Capacity (Ah)		Nominal Dimensions						Nominal Weight	
		8 Hr To 1.75 VPC @ 25°C	10 Hr To 1.80 VPC @ 20°C	Inches		Millimeters		lbs.	Kg		
M12V105FT	12	104	100	20.12	4.33	9.38	511	110	238	79	35.8
M12V125FT	12	125	121	22.00	4.90	11.15	559	124	283	105	47.6
M12V155FT	12	155	150	22.00	4.90	11.15	559	124	283	119	53.8
M12V180FT	12	180	175	22.00	4.90	12.50	559	124	318	133	60.0

MARATHON™ Front Terminal Electrical Data

Model Number	Short Circuit Current	Internal Resistance (mOhms)
M12V105FT	3125	4.0
M12V125FT	3814	3.2
M12V155FT	3883	3.0
M12V180FT	4,147	3.0

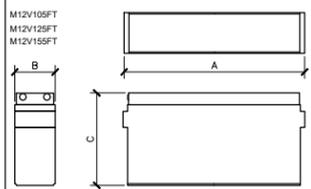

Float Voltage & Charging
Constant voltage charging is recommended.
Recommended float voltage: 27 VPC @ 25°C (77°F)
Float Voltage Range: 25 to 2.20 VPC @ 25°C (77°F)
Equalize voltage: 2.25 VPC for 24 hours

BATTERY SPECIFICATIONS

From the World Leader in VRLA Battery Technology

Designed for durability in Telecommunications, and Electric Utility applications, the GNB FRONT Terminal MARATHON™ series provides high performance and reliability in long duration discharge applications. The location of the terminals on the front (vs. the top) of the battery greatly facilitates the installation and maintenance of the product when placed in a cabinet enclosure or on a standard relay rack tray. The MARATHON™ Front Terminal battery series highlights another example of GNB's extensive experience and world wide leadership in VRLA technology.

"Designed in" Quality Manufacturing

Quality manufacturing processes for the MARATHON™ series batteries incorporate the industry's most advanced technologies including: an automated helium leak detection system, a computer controlled "fill by weight" acid filler, and a temperature controlled water bath formation process. Each and every unit is capacity tested.

High Performance MARATHON™ Series Features

- Flame-retardant reinforced container and cover compliant with UL94 V-0, 28% L.O.I.
- Integrated flash arrester ultrasonically welded into cover.
- Patented "Diamond Side-Wall" design to maintain structural integrity in higher operating temperatures.
- Heat sealed case-to-cover bond to ensure a leak proof seal.
- High-Compression Absorbent Glass Mat (AGM) technology for greater than 99% recombination efficiency.
- High-tin, calcium, silver, lead positive plate design for maximum service float life; 10 year design life @ 25°C (77°F).
- Front Accessible Copper Alloy Terminals & "Easy On/Off" Post Protector.
- Reliable one-way, self-sealing safety vents.
- Integrated Carry Handles.
- Multicell design for faster installation and reduced maintenance.

Applications

MARATHON™ series batteries incorporate GNB's advanced VRLA technology designed for long life and high performance in:

- Telecommunications
- Distributed Power
- PCS
- Cellular
- Broadband

Electric Utility

- Switchgear Control Power
- Communications



UL Recognized Component

IV. FIRE AND EXPLOSION HAZARD DATA

Flash Point: Not Applicable
Thermal Limit: LEL = 4.1% (Hydrogen Gas in air); UEL = 74.2%
Extinguishing media: CO₂; foam; dry chemical
Special Fire Fighting Procedures: Use positive pressure, self-contained breathing apparatus. Beware of acid splatter during water application and wear acid-resistant clothing, gloves, face and eye protection. If batteries are on charge, shut off power to the charging equipment, but, note that strings of series connected batteries may still pose risk of electric shock even when charging equipment is shut down.

Unusual Fire and Explosion Hazards: In operation or when on charge, batteries generate hydrogen and oxygen gases (hydrogen is highly flammable and oxygen supports combustion). They must always be assumed to contain these gases which, if ignited by burning cigarette, naked flame or spark, may cause battery explosion with dispersion of casing fragments and corrosive liquid electrolyte. Carefully follow manufacturer's instructions for installation and service. Keep away all sources of gas ignition, ensure that adequate ventilation is provided, and do not allow metallic articles to simultaneously contact the negative and positive terminals of a battery.

V. REACTIVITY DATA

Stability: Stable X Unstable ___
Conditions to Avoid: Prolonged overcharging and overheating current; sparks and other sources of ignition.

Incompatibility: (materials to avoid)
Electrolyte: Contact of sulfuric acid with combustibles and organic materials may cause fire and explosion. Also reacts violently with strong reducing agents, most metals, carbonates, chlorates, nitrites, and peroxides, sulfur trioxide gas, strong oxidizers, and water. Contact with metals may produce toxic sulfur dioxide fumes and may release flammable hydrogen gas.
Lead compounds: Avoid contact with strong acids, bases, halides, halogenates, potassium nitrate, permanganate, peroxides, nascent hydrogen, potassium, carbonates, sulfides, phosphorus, sulfur and reducing agents.

Hazardous Decomposition Products:
Electrolyte: Sulfur trioxide, carbon monoxide, sulfuric acid mist, sulfur dioxide, hydrogen sulfide, hydrogen.
Lead compounds: Temperatures above the melting point are likely to produce toxic metal fume, vapor, or dust; contact with strong acid or base or presence of nascent hydrogen may generate highly toxic zinc gas.
Hazardous Polymerization: May Occur ___ Will Not Occur X

VI. HEALTH HAZARD DATA

Routes of Entry:
Electrolyte: Harmful by all routes of entry. Under normal conditions of use, sulfuric acid vapors and mist are not generated. Sulfuric acid vapors and mist may be generated when product is overheated, oxidized, or otherwise processed or damaged.
Lead compounds: Under normal conditions lead dust, vapor, and fumes are not generated. Hazardous exposure can occur only when product is heated above the melting point, oxidized or otherwise processed or damaged to create dust, vapor, or fume.

Inhalation:
Electrolyte: Breathing of sulfuric acid vapors or mists may cause severe respiratory irritation.
Lead compounds: Inhalation of lead dust or fumes may cause irritation of upper respiratory tract and lungs.

Ingestion:
Electrolyte: May cause severe irritation of mouth, throat, esophagus, and stomach.
Lead compounds: Acute ingestion may cause abdominal pain, nausea, vomiting, diarrhea, and severe cramping. This may lead rapidly to systemic toxicity. Acute ingestion should be treated by physician.

Skin Contact/Skin Absorption:
Electrolyte: Severe irritation, burns, and ulceration. Sulfuric acid is not readily absorbed through the skin.
Lead compounds: Not readily absorbed through the skin.

Eye Contact:
Electrolyte: Severe irritation, burns, cornea damage, blindness.
Lead compounds: May cause eye irritation.

299-MSDS-MARSPRV Rev. AG 2010-01 Page 2 of 5
ANY PHOTOCOPIY MUST BE OF THIS ENTIRE DOCUMENT

FIRE DEPARTMENT NOTES:

A. FIRE DEPARTMENT FINAL INSPECTION REQUIRED. SCHEDULE INSPECTION 2 DAYS IN ADVANCE.

B. A CFC PERMIT TO OPERATE BATTERY SYSTEMS WITH STATIONARY LEAD-ACID BATTERIES IS NOT REQUIRED FOR THE QUANTITIES ON SITE.

C. A CFC PERMIT MAY BE REQUIRED FOR THE HAZARDOUS MATERIALS ON SITE.

D. A HAZARDOUS MATERIALS IDENTIFICATION SIGN IS REQUIRED FOR ALL ENTRANCES INTO BATTERY STORAGE AREAS. LETTERS MUST BE AT LEAST 1" IN HEIGHT AND IN A COLOR WHICH CONTRASTS TO THE BACKGROUND OF THE SIGN AND LIST THE FOLLOWING:

CLASS 1 WATER REACTIVE LIQUID
TOXIC LIQUID
CORROSIVE LIQUID
OTHER HEALTH HAZARD LIQUID

E. AN APPROVED METHOD TO NEUTRALIZE SPILLED ELECTROLYTE SHALL BE PROVIDED IN THE BATTERY ROOM.

F. BATTERIES SHALL BE PROVIDED WITH SAFETY VENTING CAPS.

G. LOCATIONS AND CLASSIFICATIONS OF EXTINGUISHERS SHALL BE IN ACCORDANCE WITH THE CALIFORNIA FIRE CODE STANDARD 10-1 AND PLACEMENT IS SUBJECT TO APPROVAL OF THE FIRE INSPECTOR.

H. STORAGE, DISPENSING OR USE OF ANY FLAMMABLE AND COMBUSTIBLE LIQUIDS, FLAMMABLE AND COMPRESSED GASES, AND OTHER HAZARDOUS MATERIALS SHALL COMPLY WITH CALIFORNIA FIRE CODE REGULATIONS.

I. EXIST DOORS SHALL BE ABLE TO OPEN FROM THE INSIDE WITHOUT THE USE OF KEY OR ANY SPECIAL KNOWLEDGE OR EFFORT.

J. ADDRESS NUMBERS SHALL BE A MINIMUM 6 INCHES HIGH AND PLAINLY VISIBLE FROM ROADWAY BUILDING IS ADDRESSED ON.

Battery: GNB Marathon 12MV 155FT

	Number of Strings	Modules per String	Total Modules	Unpacked Weight per Module
	2	4	8	119 lbs

Material	Pounds
Lead 74% (avg) per MSDS	74%
Total Lead	704

Material	Gals
Electrolyte per Module (17% by wt.)	2.5
Total Electrolyte	20.2



5001 EXECUTIVE PKWY
SAN RAMON, CA 94583



575 LENNON LANE, SUITE 125
WALNUT CREEK, CA 94598



26455 RANCHO PARKWAY SOUTH
LAKE FOREST, CALIFORNIA 92630

JOB NUMBER 469-001

REV	DATE	DESCRIPTION
3	06/19/19	CHANGE TO MONOPOLE
2	05/16/19	90% CONSTRUCTION DRAWINGS
1	04/26/19	90% CONSTRUCTION DRAWINGS
0	04/17/19	90% CONSTRUCTION DRAWINGS

IT IS A VIOLATION OF LAW FOR ANY PERSON, UNLESS THEY ARE ACTING UNDER THE DIRECTION OF A LICENSED PROFESSIONAL ENGINEER, TO ALTER THIS DOCUMENT.

CCL04830
CUERVO HOLDINGS
51500 PINE CANYON
KING CITY, CA 93930
TOWER/CWIC

SHEET TITLE
FIRE DEPARTMENT /
BATTERY INFO

SHEET NUMBER

F-1

EXIDE TECHNOLOGIES MATERIAL SAFETY DATA SHEET

L. PRODUCT IDENTIFICATION

MANUFACTURER: Exide Technologies Industrial Energy
3950 Sussex Avenue, Aurora, IL 60504-7932

CHEMICAL/TRADE NAME: MARATHON V-0 and SPRINTER V-0 Valve Regulated Lead Acid Battery

FOR INFORMATION: Primary: MACTEC Engineering and Consulting, Inc. Attention: Julian Corham (770) 421-5485
Secondary: Environmental, Safety & Health. Attention: Eric Murray (800) 532-4622 or Fred Gunster (610) 921-4052

FOR EMERGENCY: CHEMTREC (800) 424-9300
24-hour Emergency Response Contact: Ask for Environmental Coordinator

CHEMICAL FAMILY/CLASSIFICATION: Electrical Storage Battery Monoblock type
DATE ISSUED: January 2010

CHEMTREC INTERNATIONAL (703) 527-3887 - Collect

II. HAZARDOUS INGREDIENTS IDENTIFICATION

Components	CAS Number	% by Wt	OSHA	ACGIH	NIOSH
Inorganic components of:					
Lead	7439-92-1	71.76	50	50	50
Antimony Oxide	7440-38-0	< 0.6	350	350	350
Calcinated Clay	N/A	< 1.2	N/A	N/A	N/A
Tin	7440-31-5	0.4-0.6	2000	2000	2000
Copper	7440-50-8	< 0.1	1000	1000	1000
Electrolyte (sulfuric acid)	7664-93-9	16.18	1000	200	1000
Case Material:					
Polypropylene	9003-07-0	6.7	N/A	N/A	N/A
Plate separator material:					
Glass	N/A	2.3	N/A	N/A	N/A

NOTE: Inorganic lead and electrolyte (water and sulfuric acid solution) are the primary components of every battery manufactured by Exide Technologies or its subsidiaries. Other ingredients may be present dependent upon battery type. Polypropylene is the principal case material of automotive and commercial batteries.

III. PHYSICAL DATA

Boiling Point (Electrolyte)	203° F (at 760 mm Hg)	Specific Gravity (H ₂ O=1)	1.230 to 1.350
Melting Point	Not Applicable	Vapor Pressure (mm Hg at 20°C)	10
Solubility in Water	100%	Vapor Density (AIR=1)	Greater than 1
Evaporation Rate (Biphenyl acetone)	Less Than 1	% Volatiles by Weight	Not Applicable
Appearance and Odor	A clear liquid with a sharp, penetrating, pungent odor. A battery is a manufactured article; no apparent odor.		

299-MSDS-MARSPRV Rev. AG 2010-01 Page 3 of 5
ANY PHOTOCOPIY MUST BE OF THIS ENTIRE DOCUMENT

VI. HEALTH HAZARD DATA (CONTINUED)

Effects of Overexposure - Acute:
Electrolyte: Severe skin irritation, burns, damage to cornea may cause blindness, upper respiratory irritation.
Lead compounds: Headache, dizziness, abdominal pain, loss of appetite, nausea, vomiting, diarrhea, muscular aches and weakness, sleep disturbances, and irritability.

Effects of Overexposure - Chronic:
Electrolyte: Possible erosion of tooth enamel; inflammation of nose, throat, and bronchial tubes, and scarring of the cornea.
Lead compounds: Anemia; neuropathy, particularly of the motor nerves, with wrist drop; kidney damage; reproductive changes in both males and females.

Carcinogenicity:
Electrolyte: The National Toxicology Program (NTP) and the International Agency for Research on Cancer (IARC) have classified "strong inorganic acid mist containing sulfuric acid" as a substance that is carcinogenic to humans. This classification does not apply to sulfuric acid solutions in static liquid state or electrolyte in batteries. Batteries subjected to abusive charging at excessively high currents for prolonged periods of time without vent caps in place may create a surrounding atmosphere of the offensive strong inorganic acid mist containing sulfuric acid.
Lead compounds: Listed as a 2B carcinogen, likely in animals at extreme doses. Proof of carcinogenicity in humans is lacking at present.

Medical Conditions Generally Aggravated by Exposure:
Overexposure to sulfuric acid mist may cause lung damage and aggravate pulmonary conditions. Contact of electrolyte (water and sulfuric acid solution) with skin may aggravate skin diseases such as eczema and contact dermatitis. Contact of electrolyte (water and sulfuric acid solution) with eyes may damage cornea and/or cause blindness. Lead and its compounds can aggravate some forms of kidney, liver, and neurologic diseases.

Emergency and First Aid Procedures:
Inhalation:
Electrolyte: Remove to fresh air immediately. If breathing is difficult, give oxygen.
Lead compounds: Remove from exposure, gargle, wash nose, eyes, and lips; consult physician.
Ingestion:
Electrolyte: Give large quantities of water; do not induce vomiting; consult physician.
Lead compounds: Consult physician immediately.
Skin:
Electrolyte: Flush with large amounts of water for at least 15 minutes; remove contaminated clothing completely, including shoes and do not wear clothes again until cleaned. If acid is splashed on shoes, remove and discard if they contain leather.
Lead compounds: Wash immediately with soap and water. Lead compounds are not readily absorbed through the skin.
Eyes:
Electrolyte and Lead compound: Flush immediately with large amounts of water for at least 15 minutes; consult physician immediately.

VII. PRECAUTIONS FOR SAFE HANDLING AND USE

Handling and Storage:
Store batteries under roof in cool, dry, well-ventilated areas that are separated from incompatible materials and from activities which may create flames, sparks, or heat. Keep away from metallic objects that could bridge the terminals on a battery and create a dangerous short-circuit. Single batteries pose no risk of electric shock but there may be increasing risk of electric shock from strings of connected batteries exceeding three 12-volt units.

Charging:
There is a possible risk of electric shock from charging equipment and from strings of series connected batteries, whether or not being charged. Shut-off power to the charger when not in use and before disconnection of any circuit connections. Batteries being charged will generate and release flammable hydrogen gas. Charging space should be ventilated. Keep battery vent caps in position. Prohibit smoking and avoid creation of flames and sparks nearby. Wear face and eye protection when near batteries being charged.

Spill or Leak Procedures:
Remove combustible materials and all sources of ignition. Stop flow of material and contain spill by diking with soda ash, etc. Carefully neutralize spill with soda ash, etc. Make certain mixture is neutral then collect residue and place in a drum or other suitable container with a label specifying "contains hazardous waste" (or if uncertain call distributor regarding proper labeling procedure). Dispose of as hazardous waste. If battery is leaking, place battery in a heavy duty plastic bag. Wear acid resistant boots, face shield, chemical splash goggles and acid resistant gloves. DO NOT RELEASE UNNEUTRALIZED ACID.

299-MSDS-MARSPRV Rev. AG 2010-01 Page 3 of 5
ANY PHOTOCOPIY MUST BE OF THIS ENTIRE DOCUMENT

IX. OTHER REGULATORY INFORMATION (CONTINUED)

CERCLA (Superfund) and EPCRA:
(a) Reportable Quantity (RQ) for spilled 100% sulfuric acid under CERCLA (Superfund) and EPCRA (Emergency Planning and Community Right to Know Act) is 1,000 lbs. State and local reporting quantities for spilled sulfuric acid may vary.
(b) Sulfuric acid is a listed "Extremely Hazardous Substance" under EPCRA, with a Threshold Planning Quantity (TPQ) of 1,000 lbs.
(c) EPCRA Section 302 notification is required if 1,000 lbs or more of sulfuric acid is present at one site. An average automotive/commercial battery contains approximately 5 lbs of sulfuric acid. Contact your Exide representative for additional information.
(d) EPCRA Section 312 Tier Two reporting is required for non-automotive batteries if sulfuric acid is present in quantities of 500 lbs or more and/or if lead is present in quantities of 10,000 lbs or more.
Supplier Notification:
This product contains a toxic chemical or chemicals subject to the reporting requirements of section 313 of (Title) III of the Superfund Amendments and Reauthorization Act of 1986 and 40 CFR Part 372.
Chemical CAS Percent by Weight
Lead (Pb) 7439-92-1 71.76
Electrolyte: Sulfuric Acid 7664-93-9 16.18
If you distribute this product to other manufacturers in SIC Codes 20 through 39, this information must be provided with the first shipment of each calendar year.
Note: The Section 313 supplier notification requirement does not apply to batteries that are "consumer products".
CAA: Exide Technologies supports preventative actions concerning ozone depletion in the atmosphere due to emissions of CFC's and other ozone depleting chemicals (ODCs), defined by the USEPA as Class I substances. Pursuant to Section 611 of the Clean Air Act Amendments (CAAA) of 1990, finalized on January 19, 1993, Exide established a policy to eliminate the use of Class I ODC's prior to the May 15, 1993 deadline.
TSCA: Each ingredient chemical listed in Section II of this MSDS is also listed on the TSCA Registry.
CANADIAN REGULATIONS: All chemical substances in this product are listed on the CEPA DSL/NDSL or are exempt from list requirements.
CALIFORNIA PROPOSITION 65:
"WARNING: This product contains lead, a chemical known to the State of California to cause cancer, or birth defects or other reproductive harm."
PREPARED BY:
EXIDE TECHNOLOGIES INDUSTRIAL ENERGY
3950 SUSSEX AVENUE
AURORA, IL 60504-7932
(800) 672-0471
VENDOR AND THIRD PERSONS ASSUME THE RISK OF INJURY PROXIMATELY CAUSED BY THE MATERIAL IF REASONABLE SAFETY PROCEDURES ARE NOT FOLLOWED AS PROVIDED FOR IN THIS DATA SHEET, AND VENDOR SHALL NOT BE LIABLE FOR INJURY TO VENDOR OR THIRD PERSONS PROXIMATELY CAUSED BY ABNORMAL USE OF THE MATERIAL EVEN IF REASONABLE PROCEDURES ARE FOLLOWED.
ALL PERSONS USING THIS PRODUCT, ALL PERSONS WORKING IN AN AREA WHERE THIS PRODUCT IS USED, AND ALL PERSONS HANDLING THIS PRODUCT SHOULD BE FAMILIAR WITH THE CONTENTS OF THIS DATA SHEET. THIS INFORMATION SHOULD BE EFFECTIVELY COMMUNICATED TO EMPLOYEES AND OTHERS WHO MIGHT COME IN CONTACT WITH THE PRODUCT.
WHILE THE INFORMATION ACCUMULATED AND SET FORTH HEREIN IS BELIEVED TO BE ACCURATE AS OF THE DATE HEREOF, EXIDE TECHNOLOGIES MAKES NO WARRANTY WITH RESPECT THERETO AND DISCLAIMS ALL LIABILITY FROM RELIANCE THEREON. RECIPIENTS ARE ADVISED TO CONFIRM IN ADVANCE OF NEED THAT THE INFORMATION IS CURRENT, APPLICABLE, AND SUITABLE FOR THEIR PARTICULAR CIRCUMSTANCES.

299-MSDS-MARSPRV Rev. AG 2010-01 Page 3 of 5
ANY PHOTOCOPIY MUST BE OF THIS ENTIRE DOCUMENT

VIII. PRECAUTIONS FOR SAFE HANDLING AND USE (CONTINUED)

Waste Disposal Methods:
Sulfuric Acid: Neutralize as described above for a spill, collect residue and place in a container labeled as containing hazardous waste. Dispose of as a hazardous waste. If uncertain about labeling procedures, call your local battery distributor or listed contact. DO NOT FLUSH LEAD CONTAMINATED ACID TO SEWER.
Spent batteries: Send to secondary lead smelter for recycling following applicable federal, state, and local regulations.
Precautionary Labeling:
POISON - CAUSES SEVERE BURNS
DANGER - H2SO4 (SULFURIC ACID)
CORROSIVE - CONTAINS SULFURIC ACID
KEEP AWAY FROM CHILDREN

VIII. CONTROL MEASURES

Engineering Controls and Work Practices:
Store and handle in well-ventilated areas. If mechanical ventilation is used, components must be acid-resistant.
Handle batteries carefully. Make certain vent caps are on securely. If battery case is damaged, avoid bodily contact with internal components. Wear protective clothing, eye and face protection, when charging or handling batteries. Follow all manufacturers' recommendations when stacking or palletizing. Do not allow parallel contacts to simultaneously contact both the positive and negative terminals of the batteries. Use a battery carrier to lift a battery or place hands at opposite corners to avoid spilling acid through the vents. Avoid contact with internal components of the batteries.

Hygiene Practices:
Wash hands thoroughly before eating, drinking or smoking after handling batteries.

Respiratory Protection:
None required under normal conditions. If an overcharging or overheating condition exists and concentrations of sulfuric acid mist are known or suspected to exceed PEL, use NIOSH or MSHA approved respiratory protection.

Protective Clothing:
None required under normal conditions. If battery case is damaged, use rubber or plastic acid-resistant gloves with elbow-length gauntlet, acid-resistant apron, clothing, and boots.

Eye Protection:
None required under normal conditions. If battery case is damaged, chemical goggles or face shield.

Emergency Flashing:
In areas where water and sulfuric acid solutions are handled in concentrations greater than 1%, emergency eyewash stations and showers should be provided, with unlimited water supply.

IX. OTHER REGULATORY INFORMATION

NFPA Hazard Rating for sulfuric acid:
Hazardous by (Red) = 0 Health (Blue) = 3 Reactivity (Yellow) = 2
TRANSPORTATION:
Not regulated pursuant to §173.159(d) of the DOT Hazardous Materials Regulations (49 CFR Part 173.159) provided each package is marked "NON-FLAMMABLE LIQUID". For shipping purposes, reference IATA Dangerous Goods Regulations Special Provision A67. For ocean shipments, reference IMDG Special Provision #28.
Note: Exide Technologies batteries which have met the test requirements for "non-spillable batteries" in shipment must be protected against short circuit and securely packaged.
Label: NONSPILLABLE LIQUID
RCRA: Spent lead acid batteries are not regulated as hazardous waste when recycled. Spilled sulfuric acid is a characteristic hazardous waste; H2A hazardous waste number 3002 (corrosivity).

299-MSDS-MARSPRV Rev. AG 2010-01 Page 4 of 5
ANY PHOTOCOPIY MUST BE OF THIS ENTIRE DOCUMENT

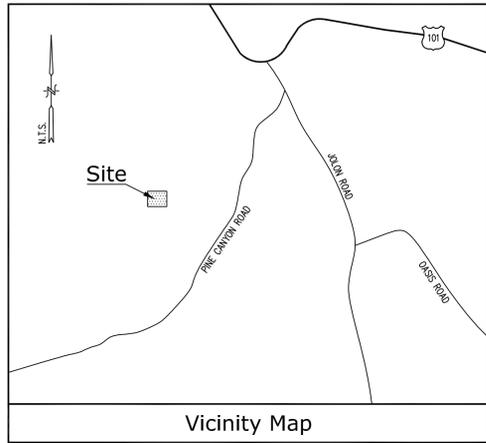

Lease Area Detail
SCALE: 1"=20'

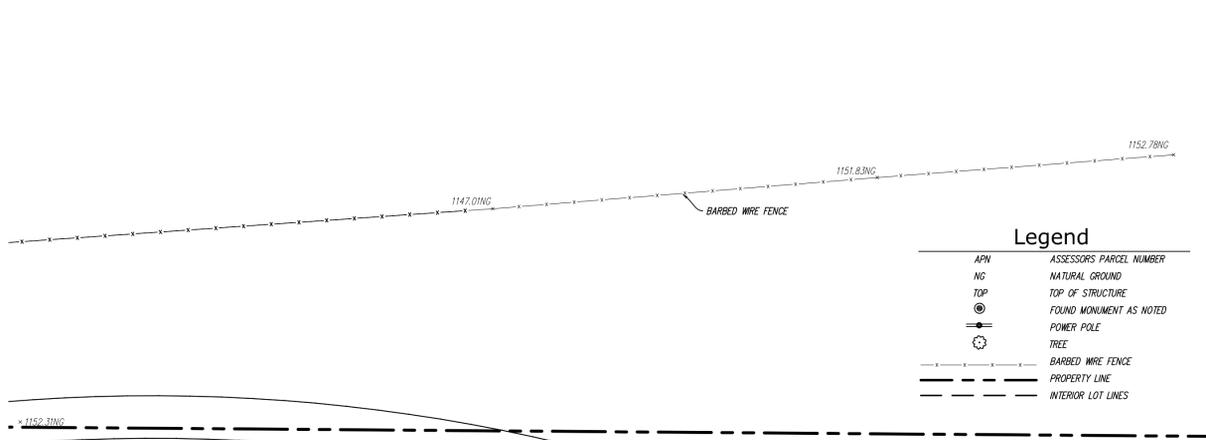

Title Report

PREPARED BY: FIDELITY NATIONAL TITLE INSURANCE COMPANY
ORDER NO.: 27443096
DATED: JUNE 25, 2018

Legal Description

PROPERTY LOCATED IN MONTEREY, CA

A PARCEL OF LAND IN SECTIONS 23, 24 AND 25, TOWNSHIP 20 SOUTH, RANGE 7 EAST 40M, MONTEREY COUNTY, CALIFORNIA BEING THE NE 1/4 OF THE SE 1/4 OF SAID SECTION 23 TOGETHER WITH A PORTION OF THE S 1/2 OF SAID SECTION 24, TOGETHER WITH THE NW 1/4 OF THE NW 1/4 OF SAID SECTION 25, PARTICULARLY DESCRIBED AS FOLLOWS:

BEGINNING AT AN IRON PIPE SET AT THE INTERSECTION OF THE NORTHWEST BOUNDARY OF PINE CANYON ROAD, A COUNTY ROAD 40 FEET WIDE, WITH THE SOUTH BOUNDARY OF THE ABOVE MENTIONED SECTION 24 FROM WHICH POINT AN IRON PIPE FOUND AT THE SOUTHWEST CORNER OF SAID SECTION 24 BEARS ALONG SAID SOUTH BOUNDARY N. 89 DEG. 15' 22" E., 1385.27 FEET AND RUNNING THENCE FROM SAID POINT OF BEGINNING ALONG SAID SOUTH BOUNDARY

(1) S. 89 DEG. 15' 22" W., 2563.81 FEET TO AN IRON PIPE SET AT THE NE CORNER OF THE NW 1/4 OF THE NW 1/4 OF SAID SECTION 25; THENCE LEAVING SAID SOUTH BOUNDARY AND RUNNING ALONG THE EAST BOUNDARY OF SAID NW 1/4 OF THE NW 1/4 OF SECTION 25

(2) S. 0 DEG. 11' 12" W., 1311.37 FEET TO AN IRON PIPE SET AT THE SE CORNER OF THE NW 1/4 OF THE NW 1/4 OF SAID SECTION 25; THENCE LEAVING SAID EAST BOUNDARY AND RUNNING ALONG THE SOUTH BOUNDARY OF SAID NW 1/4 OF THE NW 1/4 OF SAID SECTION 25

(3) S. 88 DEG. 51' 48" W., 1311.60 FEET TO AN IRON PIPE SET AT THE SW CORNER OF THE NW 1/4 OF THE NW 1/4 OF SAID SECTION 25; THENCE LEAVING SAID SOUTH BOUNDARY AND RUNNING ALONG THE WEST BOUNDARY OF SAID SECTION 25

(4) N. 0 DEG. 01' 40" W., 1320.29 FEET TO A 4" X 4" POST FOUND AT THE SW CORNER OF THE ABOVE MENTIONED SECTION 24; THENCE RUNNING ALONG THE WEST BOUNDARY OF SAID SECTION 24

(5) N. 0 DEG. 08' 51" W., 1324.74 FEET TO AN IRON PIPE SET AT THE SE CORNER OF THE NE 1/4 OF THE SE 1/4 OF SAID SECTION 23; THENCE LEAVING SAID WEST BOUNDARY AND RUNNING ALONG THE SOUTH BOUNDARY OF SAID NE 1/4 OF THE SE 1/4 OF SAID SECTION 23

(6) S. 88 DEG. 53' 08" W., 1316.14 FEET TO AN IRON PIPE SET AT THE SW CORNER OF THE NE 1/4 OF THE SE 1/4 OF SAID SECTION 23; THENCE LEAVING SAID SOUTH BOUNDARY AND RUNNING ALONG THE WEST BOUNDARY OF SAID NE 1/4 OF THE SE 1/4 OF SAID SECTION 23

(7) N. 0 DEG. 15' 57" W., 1328.47 FEET TO AN IRON PIPE SET AT THE NW CORNER OF THE NE 1/4 OF THE SE 1/4 OF SAID SECTION 23; THENCE LEAVING SAID WEST BOUNDARY AND RUNNING ALONG THE NORTH BOUNDARY OF SAID NE 1/4 OF THE SE 1/4 OF SAID SECTION 23

(8) N. 89 DEG. 05' 35" E., 1318.85 FEET TO A 3" X 3" POST FOUND AT THE 1/4 SECTION CORNER OF THE ABOVE MENTIONED SECTIONS 23 AND 24; THENCE LEAVING ALONG THE NORTH BOUNDARY OF THE S 1/2 OF THE ABOVE MENTIONED SECTION 24

(9) N. 88 DEG. 54' 52" E., 927.06 FEET TO A SET IRON PIPE; THENCE LEAVING SAID NORTH BOUNDARY AND RUNNING

(10) S. 29 DEG. 58' 13" E., 379.78 FEET, AT 113.54 FEET A SET IRON PIPE, 379.78 FEET TO A SET IRON PIPE; THENCE

(11) S. 48 DEG. 20' 45" E., 321.67 FEET TO A BRASS TAG "LS 3505" SET IN A 12" SCRUB OAK; THENCE

(12) S. 40 DEG. 06' 28" E., 186.47 FEET TO A SET IRON PIPE; THENCE

(13) S. 51 DEG. 08' 14" E., 349.09 FEET TO A SET IRON PIPE; THENCE

(14) S. 38 DEG. 14' 35" E., 323.75 FEET TO A SET IRON PIPE; THENCE

(15) S. 53 DEG. 24' 37" E., 252.85 FEET TO A SET IRON PIPE; THENCE

(16) S. 64 DEG. 50' 51" E., 462.69 FEET TO A SET IRON PIPE; THENCE

(17) S. 71 DEG. 53' 29" E., 154.85 FEET TO A SET IRON PIPE; THENCE

(18) S. 58 DEG. 05' 20" E., 311.80 FEET TO A BRASS TAG "LS 3505" SET IN THE CROTCH OF A DOUBLE 8" SCRUB OAK; THENCE

(19) S. 67 DEG. 57' 34" E., 641.05 FEET, AT 568.46 FEET A POINT HEREIN AFTER TO BE REFERRED TO AS POINT A, 641.05 FEET TO A POINT FROM WHICH A FOUND IRON PIPE BEARS SOUTH 1.50 FEET; THENCE

(20) S. 88 DEG. 38' 29" E., 220.16 FEET TO A SET IRON PIPE; THENCE

(21) N. 88 DEG. 07' 28" E., 205.66 FEET TO A POINT FROM WHICH A FOUND IRON PIPE BEARS SOUTH 1.00 FEET; THENCE

(22) S. 80 DEG. 16' 10" E., 29.17 FEET TO A SET IRON PIPE; THENCE

(23) S. 69 DEG. 20' E., 139.60 FEET TO A POINT FROM WHICH A FOUND IRON PIPE BEARS SOUTH 1.00 FEET; THENCE

(24) S. 85 DEG. 03' 45" E., 63.79 FEET TO AN IRON PIPE SET ON THE ABOVE MENTIONED NORTHWEST BOUNDARY OF PINE CANYON ROAD; THENCE RUNNING ALONG SAID NORTHWEST BOUNDARY

(25) S. 33 DEG. 41' 57" W., 69.32 FEET TO A POINT; THENCE

(26) S. 31 DEG. 23' 35" W., 186.35 FEET TO A POINT; THENCE

(27) S. 27 DEG. 44' 08" W., 328.63 FEET TO THE POINT OF BEGINNING.

EXCEPTING AN UNDIVIDED 1/2 INTEREST IN ALL MINERALS, COALS, OILS, PETROLEUM, GAS AND KINDRED SUBSTANCE UNDER AND IN SAID LAND, BUT WITHOUT RIGHT OF ENTRY OF THE SURFACE THEREOF, BUT WITH THE RIGHT HOWEVER TO DRILL IN, THROUGH OR UNDER SAID LAND OR TO EXPLORE, DEVELOP OR TAKE ALL MINERALS, COALS, OILS, PETROLEUM, GAS AND OTHER KINDRED SUBSTANCES IN AND FROM SAID LAND, ALL SUCH OPERATIONS TO BE CONDUCTED ONLY BELOW A DEPTH OF FIVE HUNDRED (500) FEET BELOW THE SURFACE THEREOF, AS EXCEPTED IN THE DEED FROM STANLEY T. WOOD AND FAYE H. WOOD, HIS WIFE, TO MARVIN G. METCALF, ALLEN L. GILL AND ALBERT J. GILL, DATED MARCH 19, 1965 AND RECORDED APRIL 09, 1965 ON REEL 399 OFFICIAL RECORDS, AT PAGE 673, MONTEREY COUNTY RECORD.

ALSO EXCEPTING UNTO MARVIN G. METCALF, ET AL AN UNDIVIDED 1/2 OF GRANOR'S INTEREST IN ALL MINERALS, COALS, OILS, PETROLEUM, GAS AND KINDRED SUBSTANCES IN, ON AND UNDER SAID LAND BUT WITHOUT RIGHT OF ENTRY OF THE SURFACE THEREOF, BUT WITH THE RIGHT HOWEVER TO DRILL IN, THROUGH OR UNDER SAID LAND OR TO EXPLORE, DEVELOP OR TAKE ALL MINERALS, COALS, OILS, PETROLEUM, GAS AND OTHER KINDRED SUBSTANCES IN AND FROM SAID LAND, ALL SUCH OPERATIONS TO BE CONDUCTED ONLY BELOW A DEPTH OF 500 FEET BELOW THE SURFACE THEREOF, BY DEED RECORDED ON JANUARY 02, 1973, IN REEL 952 OF OFFICIAL RECORDS, PAGE 970.

ALSO EXCEPTING THEREFROM ALL OIL OR MINERAL RIGHTS, TOGETHER WITH THE RIGHT TO PROSPECT FOR, DRILL FOR, MINE AND REMOVE OIL, AND MINERALS, EXCEPT OVER THE SOUTHEAST 1/4 OF SOUTHEAST 1/4 OF SECTION 24, TOWNSHIP 20 SOUTH, RANGE 7 EAST, M.D.B. & M., AS RESERVED BY FRED REICH AND ADA H. REICH IN DEED RECORDED FEBRUARY 16 1939 IN VOLUME 605 OF OFFICIAL RECORDS AT PAGE 314.

ALSO EXCEPTING THEREFROM ANY PORTION THEREOF LYING WITHIN THE BOUNDARIES OF THE COUNTY ROAD, AND BEING THE SAME PROPERTY CONVEYED TO CUERVO HOLDINGS, LP., A CALIFORNIA LIMITED PARTNERSHIP FROM AZZONA HARVESTING, A PARTNERSHIP BY GRANT DEED DATED MARCH 14, 2000 AND RECORDED MARCH 16, 2000 IN INSTRUMENT NO. 2000016991.

Assessor's Parcel No's.
420-071-067 and 420-071-068

Easements
4.— MEMORANDUM OF SEISMIC AGREEMENT AND LEASE OPTION RECORDED ON OCTOBER 17, 2008 RECORDED IN INSTRUMENT NO. 2008068794 (BLANKET IN NATURE).
5.— MEMORANDUM OF SEISMIC AGREEMENT AND LEASE OPTION RECORDED ON OCTOBER 17, 2008 RECORDED IN INSTRUMENT NO. 2008068795 (BLANKET IN NATURE).
6.— MEMORANDUM OF SEISMIC AGREEMENT AND LEASE OPTION RECORDED ON NOVEMBER 21, 2008 RECORDED IN INSTRUMENT NO. 2008076388 (BLANKET IN NATURE).

Utility Route/Lease Area
AS SHOWN

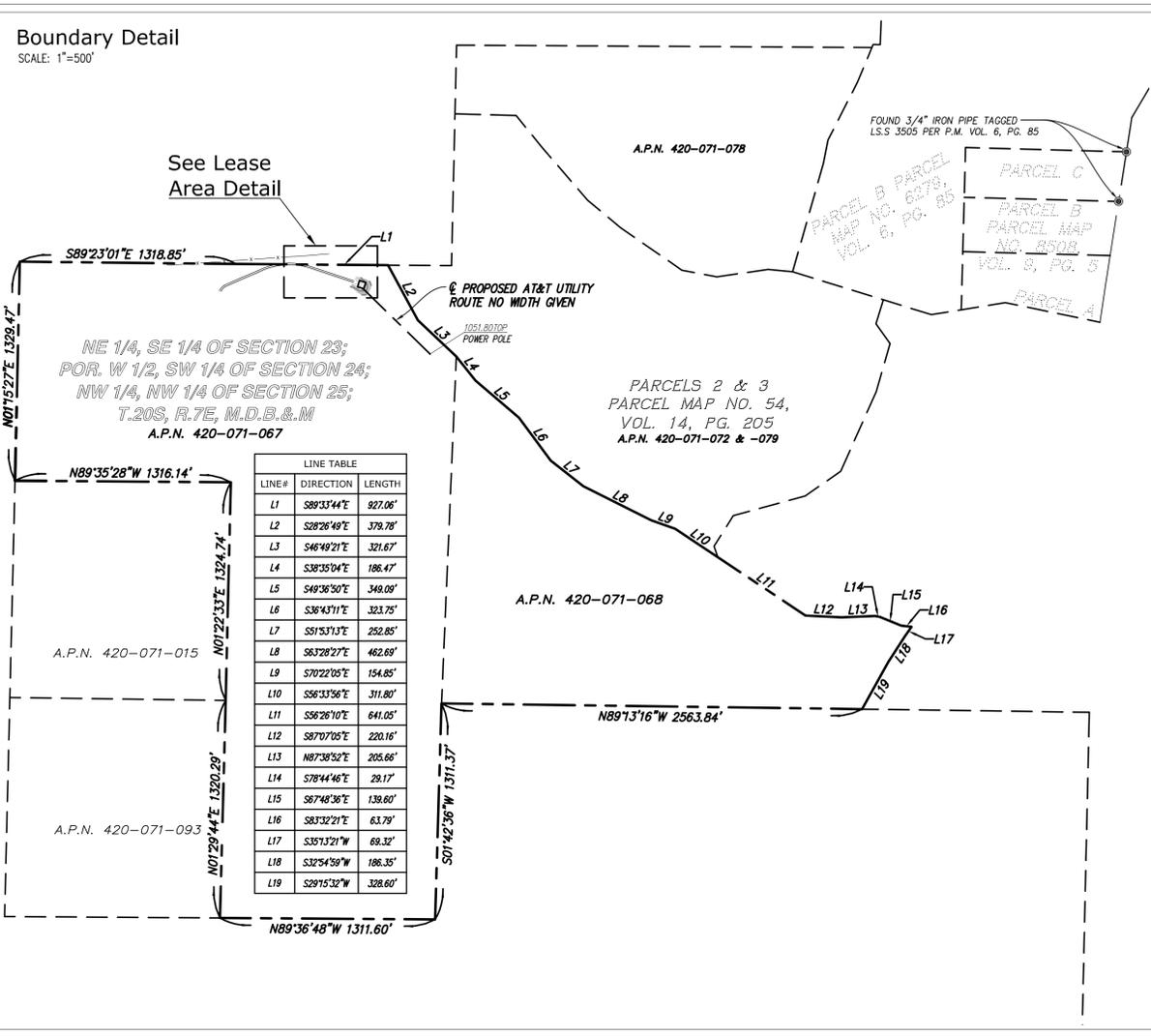

Geographic Coordinates at Self Support Tower

1983 DATUM: LATITUDE: 36° 10' 33.02"N; LONGITUDE 121° 10' 08.09"
ELEVATION = 1176.8 FEET ABOVE MEAN SEA LEVEL.

CERTIFICATION:
THE LATITUDE AND LONGITUDE SHOWN ABOVE ARE ACCURATE TO WITHIN +/- 15 FEET HORIZONTALLY AND THAT THE ELEVATIONS SHOWN ABOVE ARE ACCURATE TO WITHIN +/- 3 FEET VERTICALLY. THE HORIZONTAL DATUM (GEOGRAPHIC COORDINATES) IS IN TERMS OF THE NORTH AMERICAN DATUM OF 1983 (NAD 83) AND IS EXPRESSED IN DEGREES (°), MINUTES (') AND SECONDS ("). TO THE NEAREST HUNDREDTH OF A SECOND. THE VERTICAL DATUM (ELEVATIONS) IS IN TERMS OF THE NORTH AMERICAN VERTICAL DATUM OF 1988 (NAVD 88) AND IS DETERMINED TO THE NEAREST TENTH OF A FOOT.

Basis of Bearings

THE BASIS OF BEARINGS FOR THIS SURVEY IS THE CALIFORNIA COORDINATES SYSTEM (CCS 83), ZONE 5, 1983 DATUM, DEFINED BY SECTIONS 8801 TO 8819 OF THE CALIFORNIA PUBLIC RESOURCES CODE.

Bench Mark

THE CALIFORNIA SPATIAL REFERENCE CENTER C.O.R.S "P174", ELEVATION = 1,232.99 FEET (NAVD 88).

Date of Survey

FEBRUARY 14, 2017

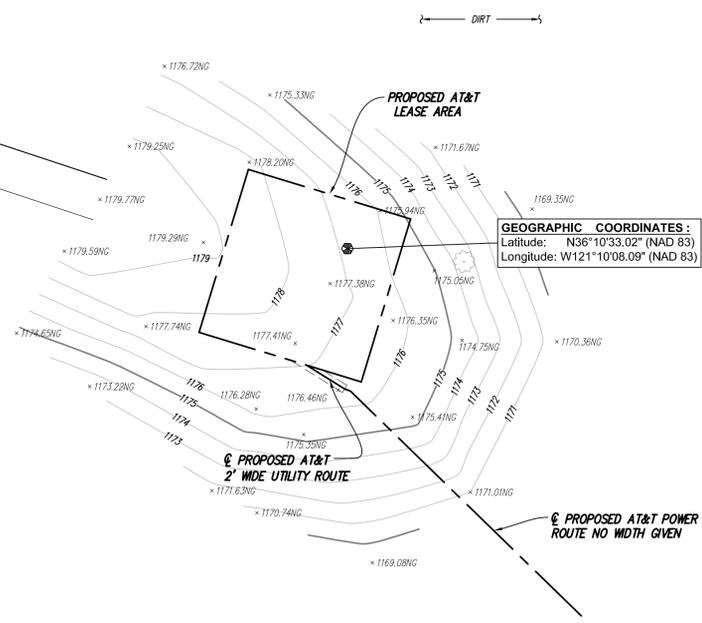

A&E DEVELOPMENT:



CONSULTANT:



LICENSURE:

REVISION:

REVISION:	DATE / BY:	DESCRIPTION:
	06/21/18	FINAL
1	07/03/18	FINAL
	02/11/19	POWER ROUTE
2	02/11/19	MM
	04/26/19	UPDATED DESIGN
3	GBM	

SITE INFORMATION:

SITE NUMBER
CCL04830

SITE NAME
CUERVO HOLDINGS

51500 PINE CANYON KING CITY, CA 93930 MONTEREY COUNTY

SHEET TITLE:
TOPOGRAPHIC SURVEY

SHEET NUMBER:

LS-1
SHEET 1 OF 1

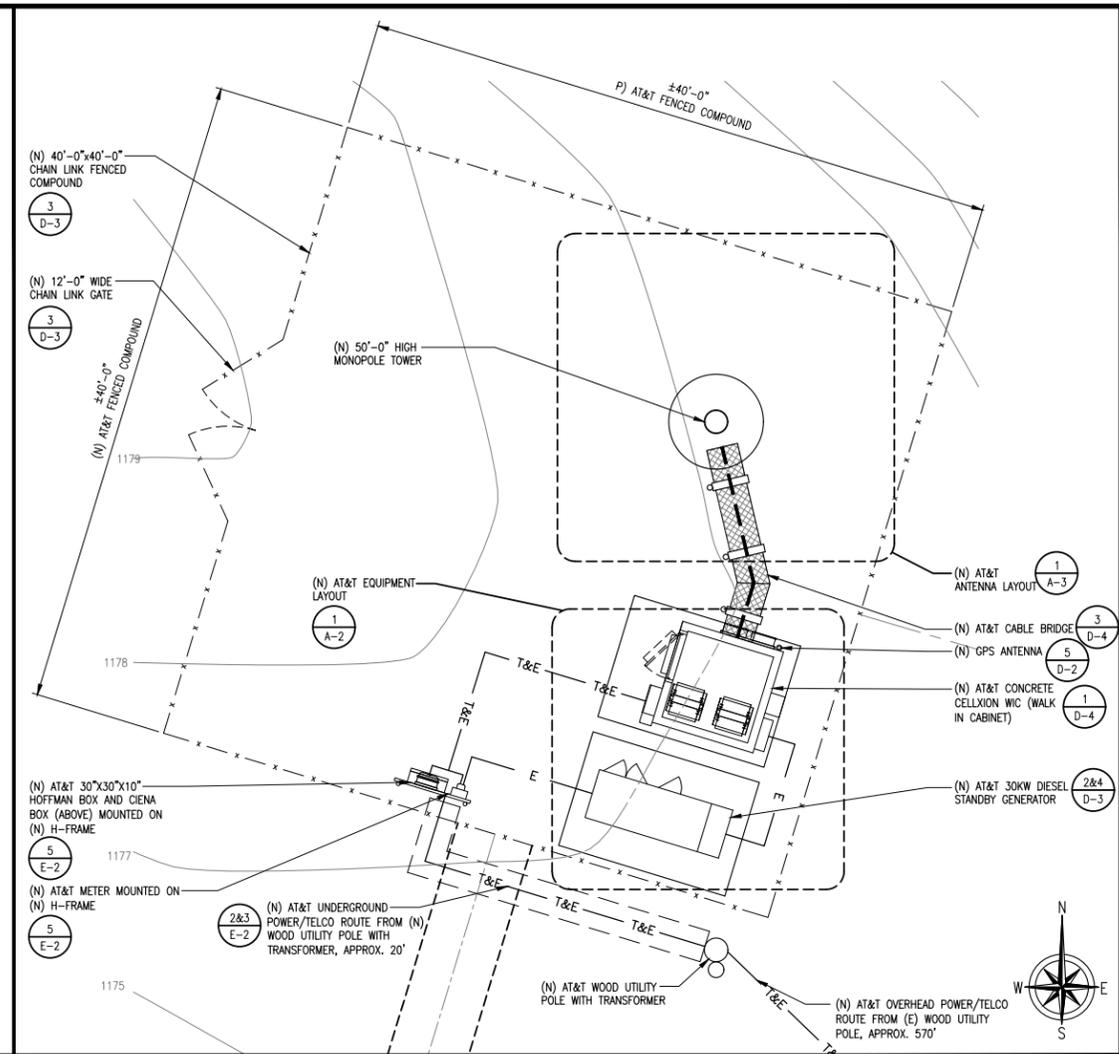
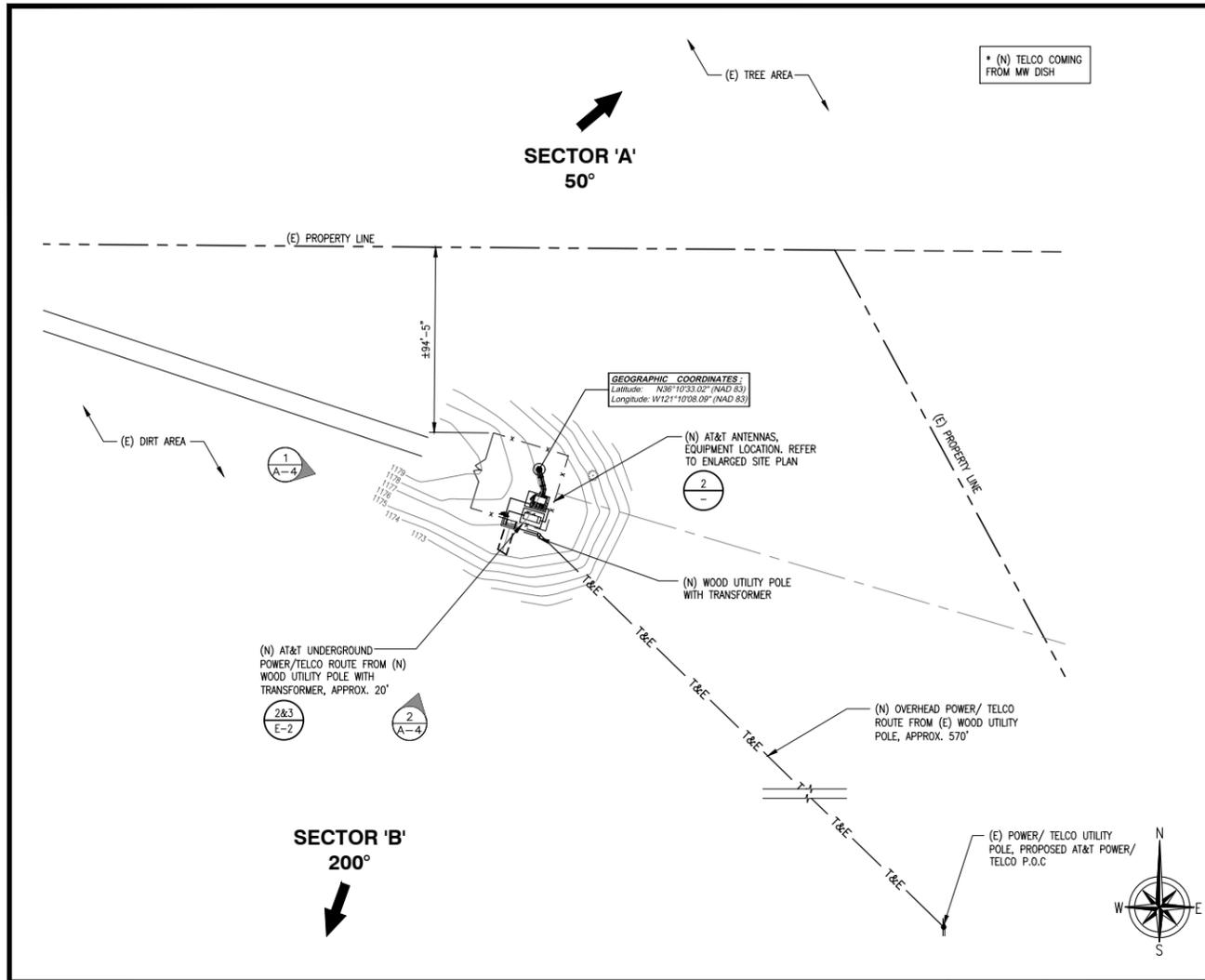

SITE PLAN

SCALE: 1" = 40'-0"
0 20' 40'

ENLARGED SITE PLAN

SCALE: 3/16" = 1'-0"
0 2' 4' 6'

OPTIMUM ANTENNA AND TRANSMISSION CABLE REQUIREMENTS (VERIFY WITH CURRENT RFDS)						
SECTOR	TECHNOLOGY	ANTENNA MODEL	ANTENNA AZIMUTH	RAD CENTER	TRANSMISSION CABLE	
	PROP.	PROPOSED	PROPOSED	PROPOSED	LENGTH	PART NUMBER
ALPHA SECTOR	A1	LTE 700/1900	KATHREIN 800-10965K	50°	47'-0"	80'-0" N/A
	A2	LTE 700	KATHREIN 800-10965K	50°	47'-0"	80'-0" N/A
	A3	LTE 700/850/AWS	KATHREIN 800-10965K	50°	47'-0"	80'-0" N/A
	A4	LTE WCS	CCI BSA-M65R-BUU-H6	50°	47'-0"	80'-0" N/A
BETA SECTOR	B1	LTE 700/1900	KATHREIN 800-10965K	200°	47'-0"	80'-0" N/A
	B2	LTE 700	KATHREIN 800-10965K	200°	47'-0"	80'-0" N/A
	B3	LTE 700/850/AWS	KATHREIN 800-10965K	200°	47'-0"	80'-0" N/A
	B4	LTE WCS	CCI BSA-M65R-BUU-H6	200°	47'-0"	80'-0" N/A

REMOTE RADIO UNITS (RRU'S)								
SECTOR	(N) RRU MODELS	RRU LOCATION (DISTANCE FROM ANTENNA)	MINIMUM CLEARANCES			DC CABLE		
			ABOVE	BELOW	SIDES	QTY.	LENGTH	AWG
ALPHA SECTOR	A1	(1) 4449 B5/B12, (1) 4415 B25	>10'	16"	8"	8"	1	80'-0" 8
	A2	(1) 4478 B14	>10'	16"	8"	8"	1	80'-0" 8
	A3	(1) RRUS-E2 B29, (1) 4426 B66	>10'	16"	8"	8"	1	80'-0" 8
	A4	(2) 4415 B30	>10'	16"	8"	8"	1	80'-0" 8
BETA SECTOR	B1	(1) 4449 B5/B12, (1) 4415 B25	>10'	16"	8"	8"	1	80'-0" 8
	B2	(1) 4478 B14	>10'	16"	8"	8"	1	80'-0" 8
	B3	(1) RRUS-E2 B29, (1) 4426 B66	>10'	16"	8"	8"	1	80'-0" 8
	B4	(2) 4415 B30	>10'	16"	8"	8"	1	80'-0" 8

ANTENNA AND RRU SCHEDULE

3

5001 EXECUTIVE PKWY
SAN RAMON, CA 94583

575 LENNON LANE, SUITE 125
WALNUT CREEK, CA 94598

INFINIGY ENGINEERING, LLP
26455 RANCHO PARKWAY SOUTH
LAKE FOREST, CALIFORNIA 92630
JOB NUMBER 469-001

REV	DATE	DESCRIPTION
3	06/19/19	CHANGE TO MONOPOLE
2	05/16/19	90% CONSTRUCTION DRAWINGS
1	04/26/19	90% CONSTRUCTION DRAWINGS
0	04/17/19	90% CONSTRUCTION DRAWINGS

IT IS A VIOLATION OF LAW FOR ANY PERSON, UNLESS THEY ARE ACTING UNDER THE DIRECTION OF A LICENSED PROFESSIONAL ENGINEER, TO ALTER THIS DOCUMENT.

CCL04830
CUERVO HOLDINGS
51500 PINE CANYON
KING CITY, CA 93930
TOWER/CWIC

SHEET TITLE
SITE PLAN, ENLARGED
SITE PLAN, ANTENNA /
RRU SCHEDULE

SHEET NUMBER
A-1



5001 EXECUTIVE PKWY
SAN RAMON, CA 94583



575 LENNON LANE, SUITE 125
WALNUT CREEK, CA 94598

INFINIGY
ENGINEERING, LLP

26455 RANCHO PARKWAY SOUTH
LAKE FOREST, CALIFORNIA 92630
JOB NUMBER 469-001

REV	DATE	DESCRIPTION
3	06/19/19	CHANGE TO MONOPOLE
2	05/16/19	90% CONSTRUCTION DRAWINGS
1	04/26/19	90% CONSTRUCTION DRAWINGS
0	04/17/19	90% CONSTRUCTION DRAWINGS

IT IS A VIOLATION OF LAW FOR ANY PERSON,
UNLESS THEY ARE ACTING UNDER THE DIRECTION
OF A LICENSED PROFESSIONAL ENGINEER,
TO ALTER THIS DOCUMENT.

CCL04830
CUERVO HOLDINGS
51500 PINE CANYON
KING CITY, CA 93930
TOWER/CWIC

SHEET TITLE
EQUIPMENT LAYOUT

SHEET NUMBER

A-2

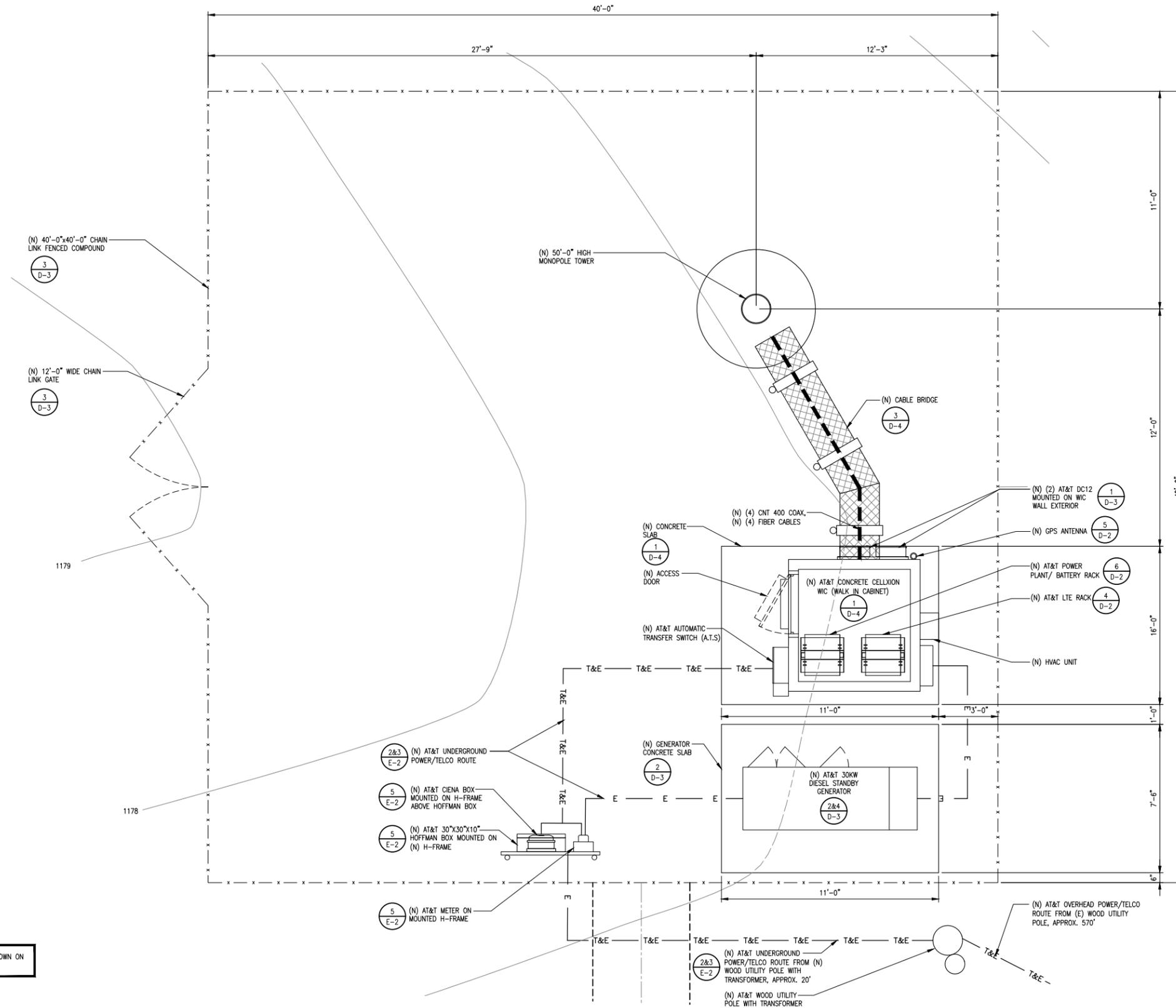

NEW AT&T ANTENNAS & RRUS NOT SHOWN ON THIS LAYOUT FOR CLARITY



SCALE: 3/8"=1'-0" 0 1' 2' 3'

1

NEW EQUIPMENT LAYOUT

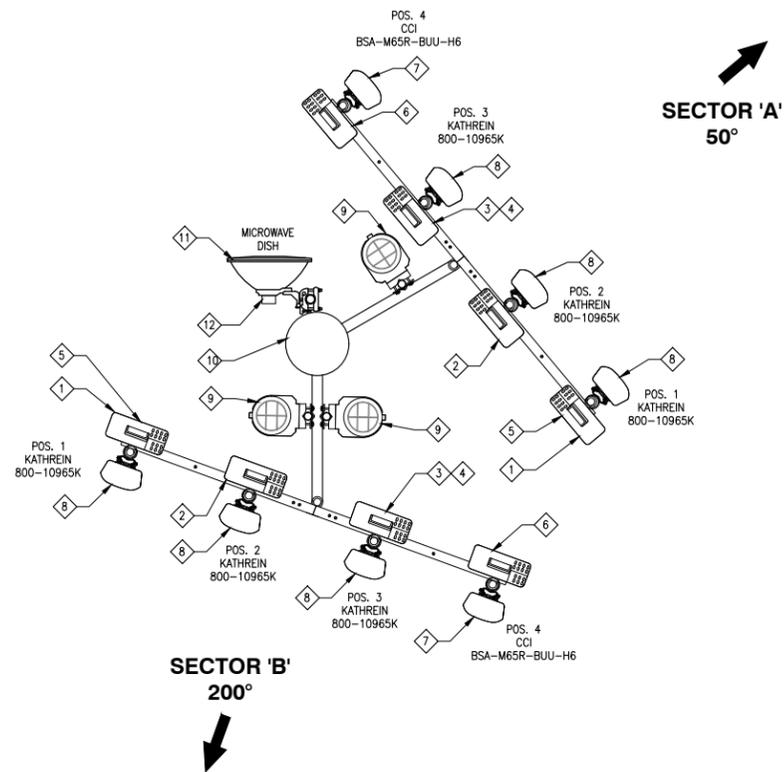

KEY NOTES:

- 1. (N) (1) 4449 B5/B12, TYP. FOR ALL TWO SECTORS, (2) TOTAL $\frac{4}{D-1}$ $\frac{1}{D-2}$
- 2. (N) (1) 4478 B14, TYP. FOR ALL TWO SECTORS, (2) TOTAL $\frac{5}{D-1}$ $\frac{1}{D-2}$
- 3. (N) (1) RRU5-E2 B29, TYP. FOR ALL TWO SECTORS, (2) TOTAL $\frac{6}{D-1}$ $\frac{1}{D-2}$
- 4. (N) (1) 4426 B66, TYP. FOR ALL TWO SECTORS, (2) TOTAL $\frac{8}{D-1}$ $\frac{1}{D-2}$
- 5. (N) (1) 4415 B25, TYP. FOR ALL TWO SECTORS, (2) TOTAL $\frac{9}{D-1}$ $\frac{1}{D-2}$
- 6. (N) (2) 4415 B30, TYP. FOR ALL TWO SECTORS, (4) TOTAL $\frac{7}{D-1}$ $\frac{1}{D-2}$
- 7. (N) (1) CCI PANEL ANTENNA MOUNTED TO (N) PIPE MOUNT, TYP. FOR ALL TWO SECTORS, (2) TOTAL $\frac{2}{D-1}$ $\frac{3}{D-1}$
- 8. (N) (3) KATHREIN 80010965K PANEL ANTENNA MOUNTED TO (N) PIPE MOUNT, TYP. FOR ALL TWO SECTORS, (6) TOTAL $\frac{1}{D-1}$ $\frac{3}{D-1}$
- 9. (N) DC-6 SQUID SURGE PROTECTION, TYP. FOR ALL TWO SECTORS, (3) TOTAL $\frac{3}{D-2}$
- 10. (N) 50'-0" HIGH MONOPOLE TOWER
- 11. (N) (1) 4' MICROWAVE DISH $\frac{4}{D-4}$
- 12. (N) (4) NOKIA HQAM ODU'S



PROPOSED ANTENNA LAYOUT

SCALE:
1/2"=1'-0"

1

NOT USED

2

5001 EXECUTIVE PKWY
SAN RAMON, CA 94583

575 LENNON LANE, SUITE 125
WALNUT CREEK, CA 94598

INFINIGY
ENGINEERING, LLP

26455 RANCHO PARKWAY SOUTH
LAKE FOREST, CALIFORNIA 92630

JOB NUMBER 469-001

REV	DATE	DESCRIPTION
3	06/19/19	CHANGE TO MONOPOLE
2	05/16/19	90% CONSTRUCTION DRAWINGS
1	04/26/19	90% CONSTRUCTION DRAWINGS
0	04/17/19	90% CONSTRUCTION DRAWINGS

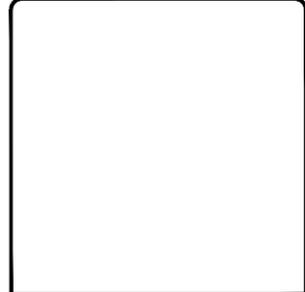

IT IS A VIOLATION OF LAW FOR ANY PERSON, UNLESS THEY ARE ACTING UNDER THE DIRECTION OF A LICENSED PROFESSIONAL ENGINEER, TO ALTER THIS DOCUMENT.

CCL04830
CUERVO HOLDINGS
51500 PINE CANYON
KING CITY, CA 93930
TOWER/CWIC

SHEET TITLE
ANTENNA LAYOUTS

SHEET NUMBER
A-3



5001 EXECUTIVE PKWY
SAN RAMON, CA 94583



575 LENNON LANE, SUITE 125
WALNUT CREEK, CA 94598

INFINIGY
ENGINEERING, LLP

26455 RANCHO PARKWAY SOUTH
LAKE FOREST, CALIFORNIA 92630

JOB NUMBER 469-001

REV	DATE	DESCRIPTION
3	06/19/19	CHANGE TO MONOPOLE
2	05/16/19	90% CONSTRUCTION DRAWINGS
1	04/26/19	90% CONSTRUCTION DRAWINGS
0	04/17/19	90% CONSTRUCTION DRAWINGS

IT IS A VIOLATION OF LAW FOR ANY PERSON,
UNLESS THEY ARE ACTING UNDER THE DIRECTION
OF A LICENSED PROFESSIONAL ENGINEER,
TO ALTER THIS DOCUMENT.

CCL04830
CUERVO HOLDINGS
51500 PINE CANYON
KING CITY, CA 93930
TOWER/CWIC

SHEET TITLE

ELEVATIONS

SHEET NUMBER

A-4

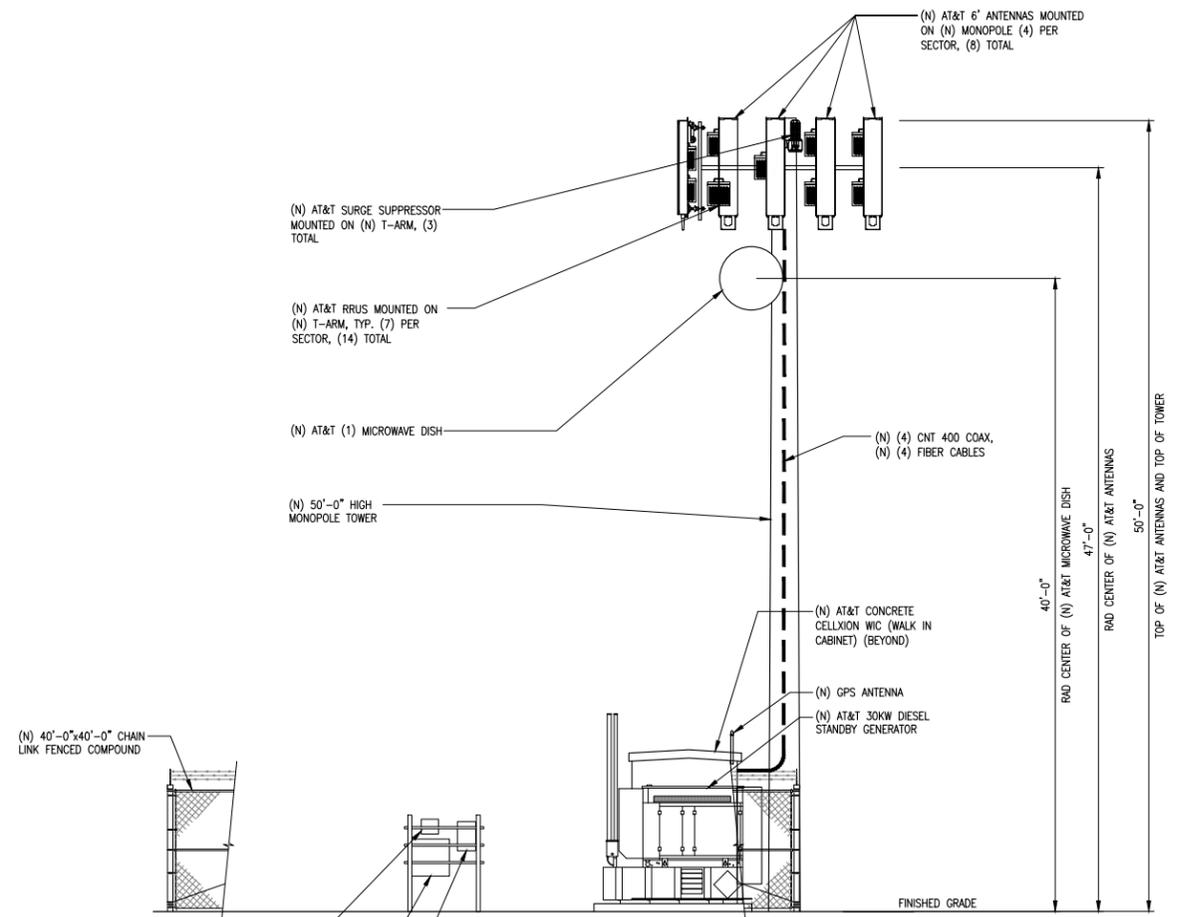
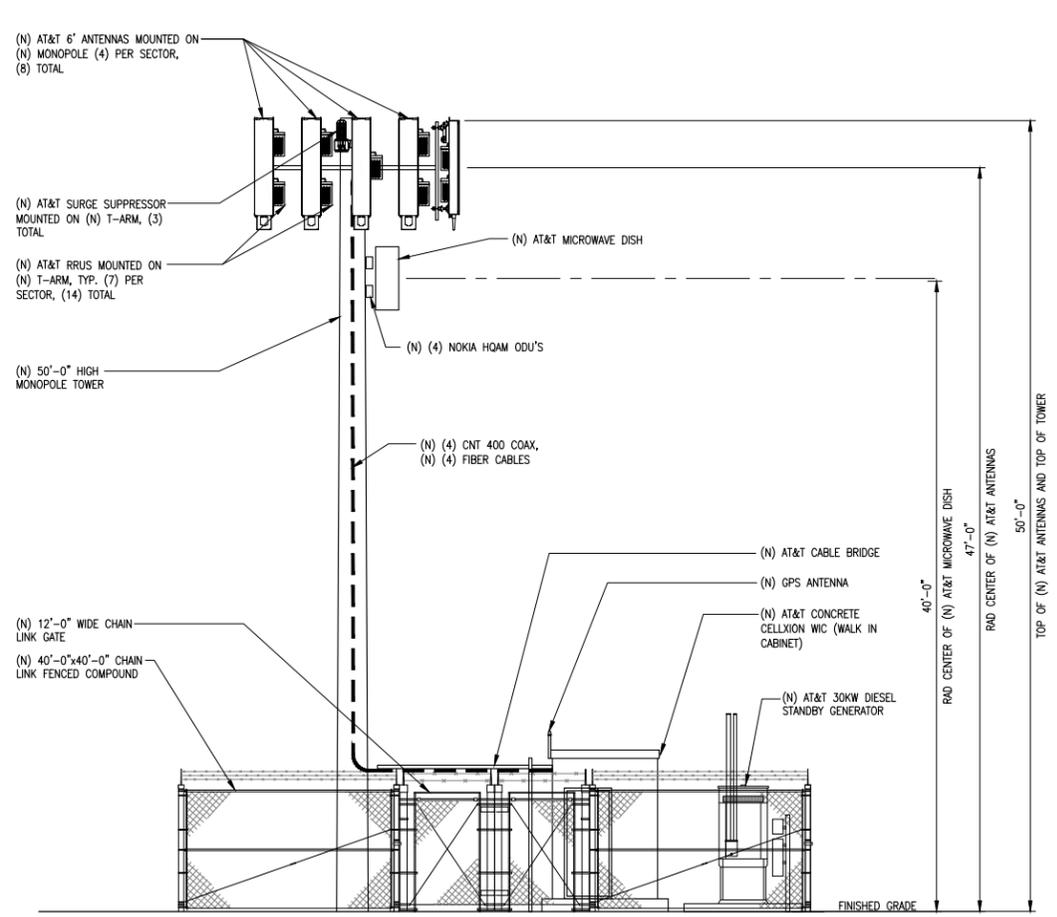

PROPOSED NORTHWEST ELEVATION

SCALE:
3/16"=1'-0"

1

PROPOSED SOUTHWEST ELEVATION

SCALE:
3/16"=1'-0"

2

ERICSSON RRUS-4415 B30

DIMENSIONS, WxDxH: 13.4"x5.9"x16.5"
 POWER CONSUMPTION: 200 WATTS
 TOTAL WEIGHT: 46 lbs
 TEMPERATURE: -40° TO 55° C

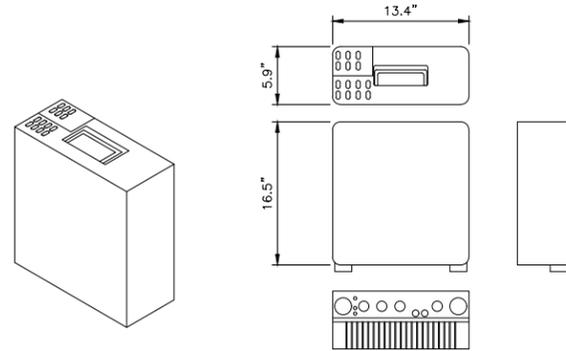

ERICSSON RRUS 4449 B5/B12

DIMENSIONS, HxWxD: 17.9"x13.19"x9.44"
 POWER CONSUMPTION: 1440 WATTS
 TOTAL WEIGHT: 71 lbs

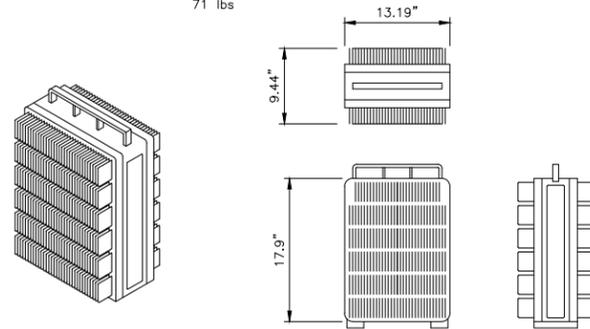

KATHREIN 6'-0" 8 PORT ANTENNA: 800-10965K
 DIMENSIONS (H X W X D): 78.7" X 20" X 6.9"
 WEIGHT: 44.3 KG / 97.6 LBS.
 W/O RET OR MOUNTING HARDWARE

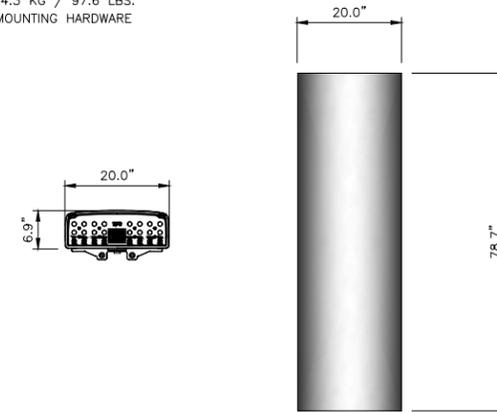

RRUS-4415 B30 SPECIFICATIONS

SCALE: NONE 7

RRUS-4449 B5/B12 SPECIFICATIONS

SCALE: NONE 4

800-10965K SPECS

SCALE: NONE 1

ERICSSON RRUS-4426 B66

DIMENSIONS, WxDxH: 13.19"x5.8"x14.96"
 POWER CONSUMPTION: 200 WATTS
 TOTAL WEIGHT: 48.4 lbs
 TEMPERATURE: -40° TO 55° C

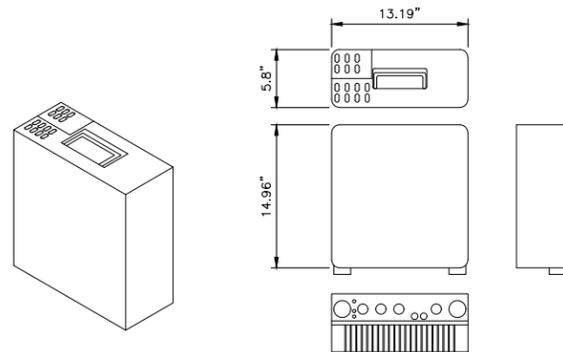

ERICSSON RRUS-4478 B14

DIMENSIONS, HxWxD: 16.5"x13.4"x7.7"
 POWER CONSUMPTION: 670 WATTS
 TOTAL WEIGHT: 59.9 lbs
 TEMPERATURE: -40° TO 55° C

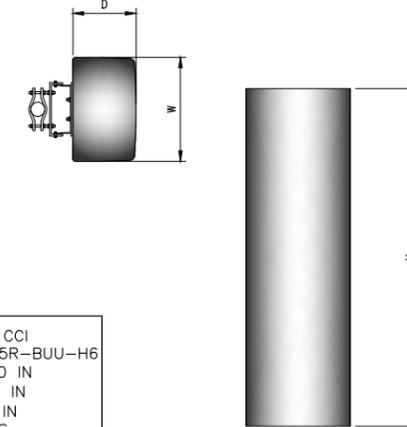
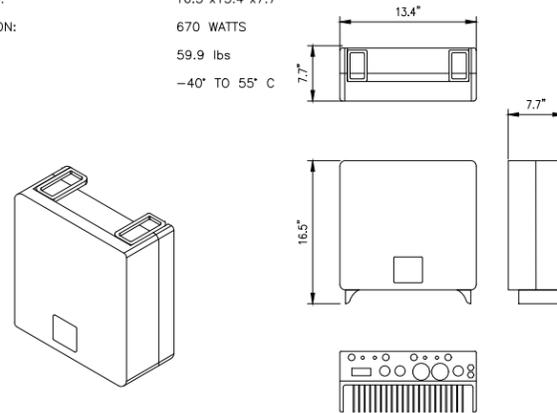

MANUFACTURER: CCI
 MODEL: BSA-M65R-BUU-H6
 HEIGHT (H): 72.0 IN
 WIDTH (W): 28.5 IN
 DEPTH (D): 9.7 IN
 WEIGHT: 101 LBS

RRUS-4426 B66 SPECIFICATIONS

SCALE: NONE 8

RRUS- 4478 B14 SPECS

SCALE: NONE 5

BSA-M65R-BUU-H6 SPECS

SCALE: NONE 2

ERICSSON RRUS-4415 B25

DIMENSIONS, WxDxH: 13.4"x5.9"x16.5"
 POWER CONSUMPTION: 200 WATTS
 TOTAL WEIGHT: 46 lbs
 TEMPERATURE: -40° TO 55° C

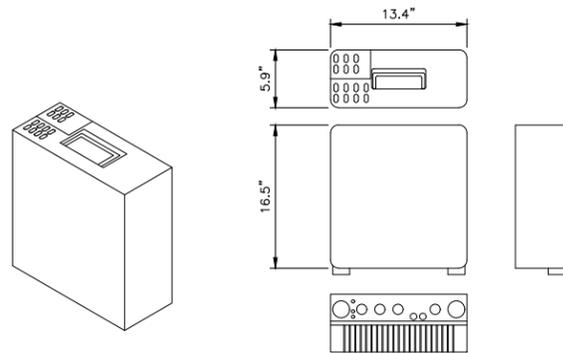

ERICSSON RRUS-E2 B29

DIMENSIONS, WxDxH: 18.5"x7.5"x20.4"
 POWER CONSUMPTION: 200 WATTS
 TOTAL WEIGHT: 53 lbs
 TEMPERATURE: -40° TO 55° C

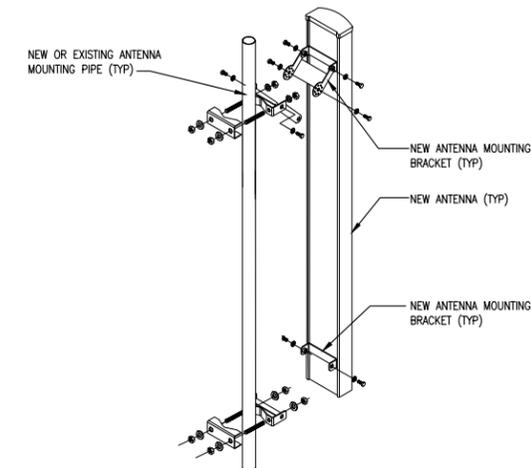
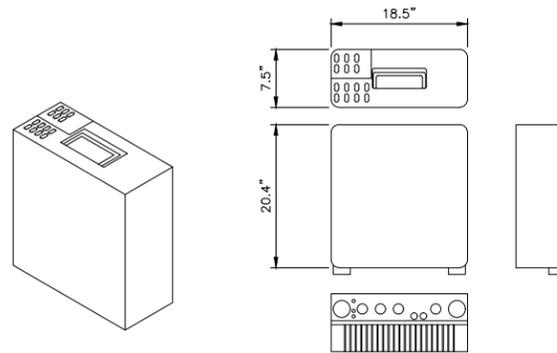

RRUS-4415 B25 SPECIFICATIONS

SCALE: NONE 9

RRUS-E2 B29 SPECIFICATIONS

SCALE: NONE 6

ANTENNA MOUNTING DETAIL

SCALE: NONE 3



5001 EXECUTIVE PKWY
 SAN RAMON, CA 94583



575 LENNON LANE, SUITE 125
 WALNUT CREEK, CA 94598

INFINIGY ENGINEERING, LLP

26455 RANCHO PARKWAY SOUTH
 LAKE FOREST, CALIFORNIA 92630
 JOB NUMBER 469-001

REV	DATE	DESCRIPTION
3	06/19/19	CHANGE TO MONOPOLE
2	05/16/19	90% CONSTRUCTION DRAWINGS
1	04/26/19	90% CONSTRUCTION DRAWINGS
0	04/17/19	90% CONSTRUCTION DRAWINGS

IT IS A VIOLATION OF LAW FOR ANY PERSON, UNLESS THEY ARE ACTING UNDER THE DIRECTION OF A LICENSED PROFESSIONAL ENGINEER, TO ALTER THIS DOCUMENT.

CCL04830
 CUERVO HOLDINGS
 51500 PINE CANYON
 KING CITY, CA 93930
 TOWER/CWIC

SHEET TITLE
**EQUIPMENT SPECS
 & DETAILS**

SHEET NUMBER
D-1

NOTE:
SPECIAL INSPECTION IS
REQUIRED FOR EXPANSION
ANCHOR INSTALLATION IN
CONCRETE PER CBC 1704.

FRAME GROUNDING CONNECTION POINTS
(1/4" ON 5/8" CENTER)

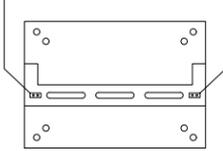

TOP VIEW
EQUIPMENT NOT SHOWN FOR CLARITY

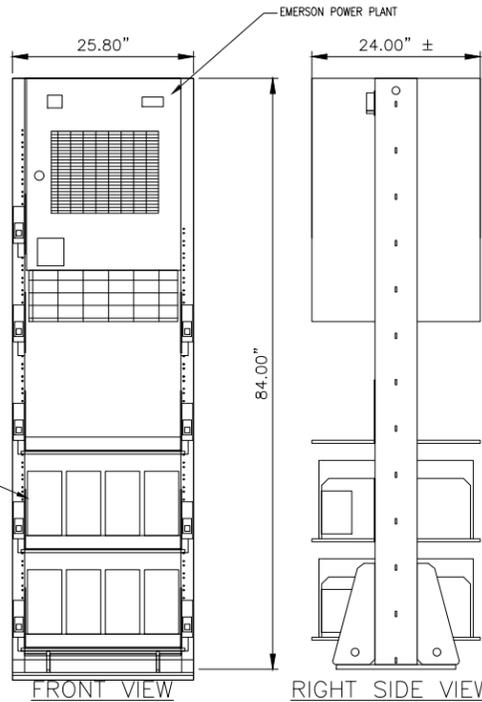

RACK WEIGHT W/O BATTERIES = 600lbs
W/(8) GNB MARATHON M12V180FT BATTERIES

SEISMIC ZONE 4 COMPLIANT

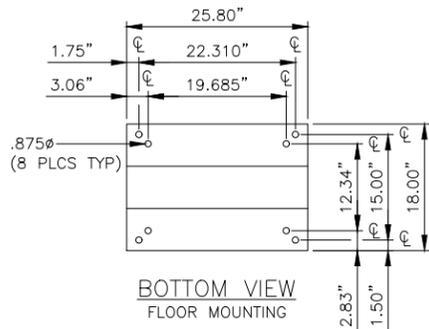

BOTTOM VIEW
FLOOR MOUNTING

EMERSON POWER PLANT DETAIL

SCALE:
NONE 6

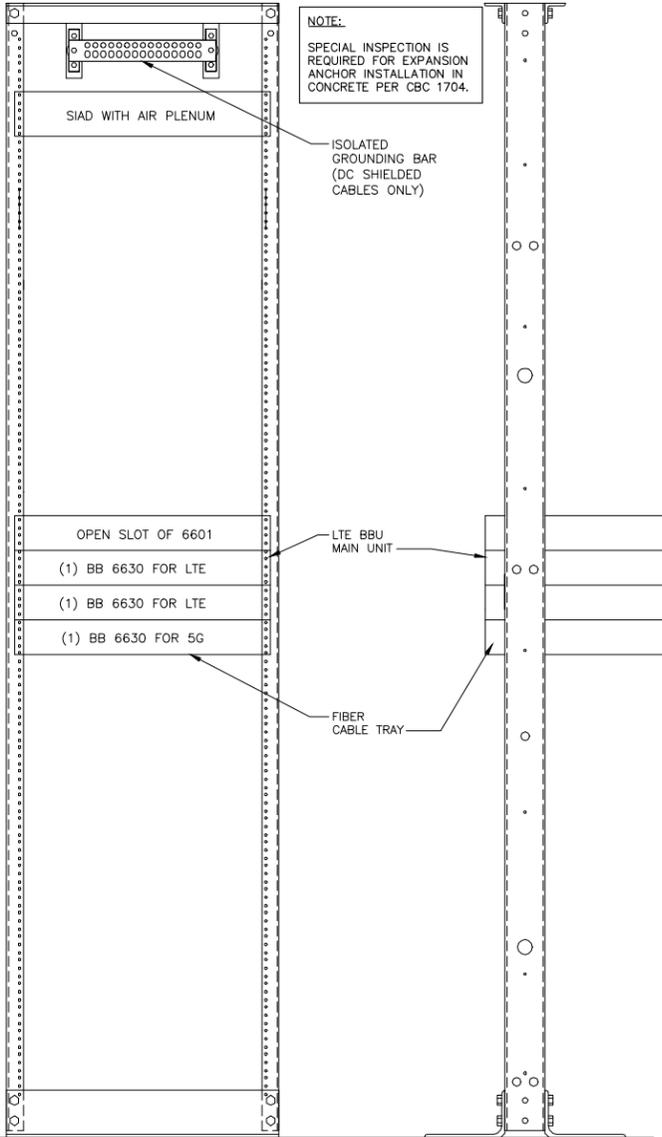

LTE RACK

SCALE:
NONE 4

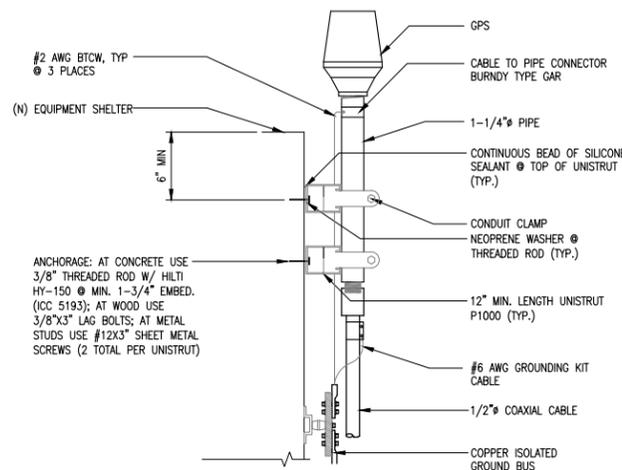

GPS DETAIL

SCALE:
NONE 5

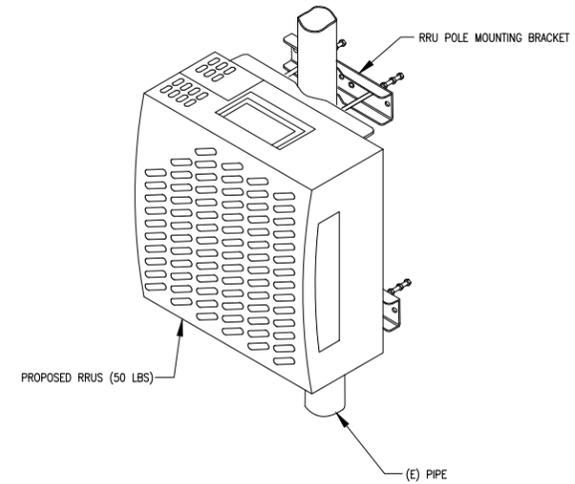

RRU MOUNTING DETAIL

SCALE:
NONE 1

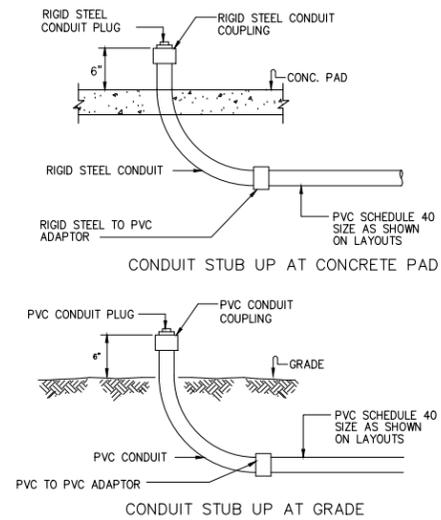

CONDUIT STUB UP

NO SCALE 2

SURGE PROTECTOR DETAIL
 • PROTECTS UP TO 6 REMOTE RADIO HEADS
 • INCLUDED FIBER CONNECTIONS FOR UP TO 18 PAIRS OF FIBER
 • 60 KA OF SURGE CURRENT CAPACITY
 • IT IS RECOMMENDED THAT UNIT BE INSTALLED WITHIN 6 FEET OF THE RADIO
 • TOTAL WEIGHT IS UNDER 20 LBS

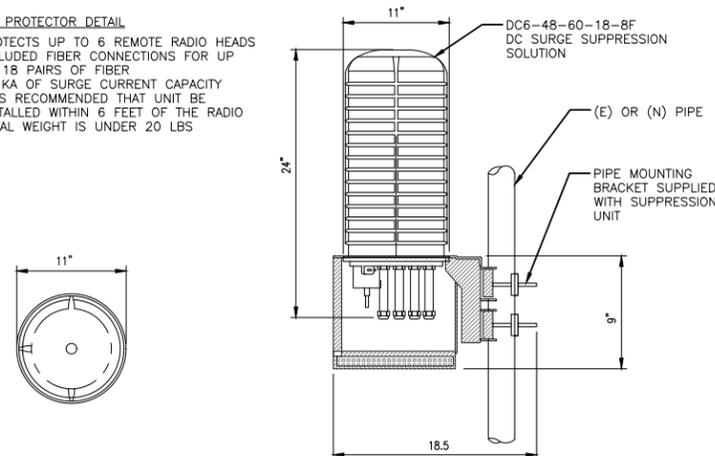

DC-6 SURGE PROTECTOR DETAIL

SCALE:
NONE 3



5001 EXECUTIVE PKWY
SAN RAMON, CA 94583



575 LENNON LANE, SUITE 125
WALNUT CREEK, CA 94598

INFINIGY
ENGINEERING, LLP

26455 RANCHO PARKWAY SOUTH
LAKE FOREST, CALIFORNIA 92630
JOB NUMBER 469-001

REV	DATE	DESCRIPTION
3	06/19/19	CHANGE TO MONOPOLE
2	05/16/19	90% CONSTRUCTION DRAWINGS
1	04/26/19	90% CONSTRUCTION DRAWINGS
0	04/17/19	90% CONSTRUCTION DRAWINGS

IT IS A VIOLATION OF LAW FOR ANY PERSON,
UNLESS THEY ARE ACTING UNDER THE DIRECTION
OF A LICENSED PROFESSIONAL ENGINEER,
TO ALTER THIS DOCUMENT.

CCL04830
CUERVO HOLDINGS
51500 PINE CANYON
KING CITY, CA 93930
TOWER/CWIC

SHEET TITLE
EQUIPMENT SPECS
& DETAILS

SHEET NUMBER

D-2

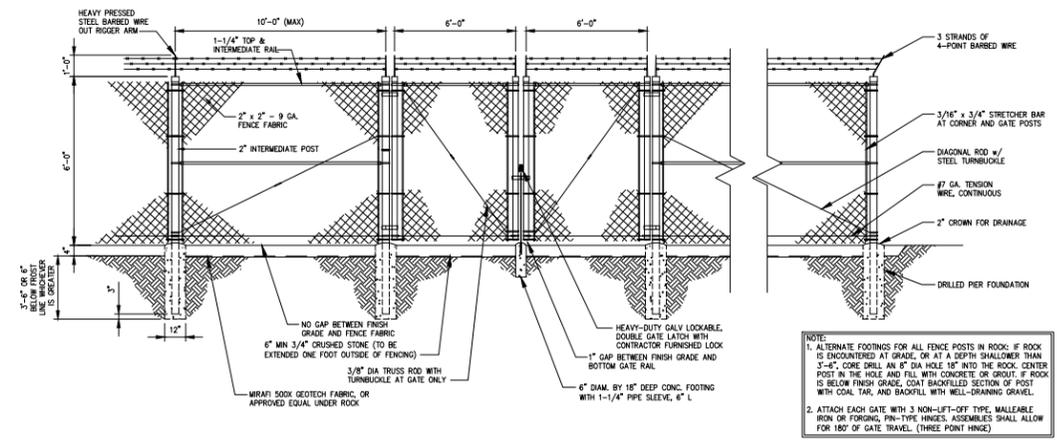

CHAIN LINK FENCE & GATE DETAIL

SCALE: NONE 3

DC SURGE PROTECTION SOLUTIONS DC12-48-60-0-25E

DIMENSIONS, HxWxD: 24.00"x24.00"x8.00"
 VOLTAGE PROTECTION RATING (VPR): 400V
 VOLTAGE PROTECTION RATING [Up]: 410V
 TOTAL WEIGHT: 56.3 lbs

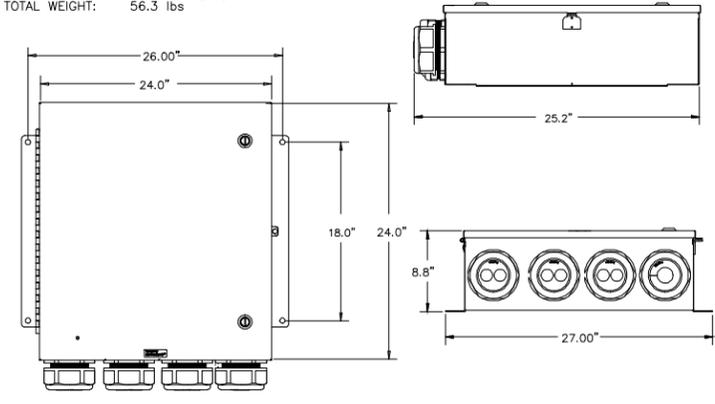

DC-12 SURGE SUPPRESSOR

SCALE: NONE 1



5001 EXECUTIVE PKWY
 SAN RAMON, CA 94583



575 LENNON LANE, SUITE 125
 WALNUT CREEK, CA 94598

OJ7500D-ATT

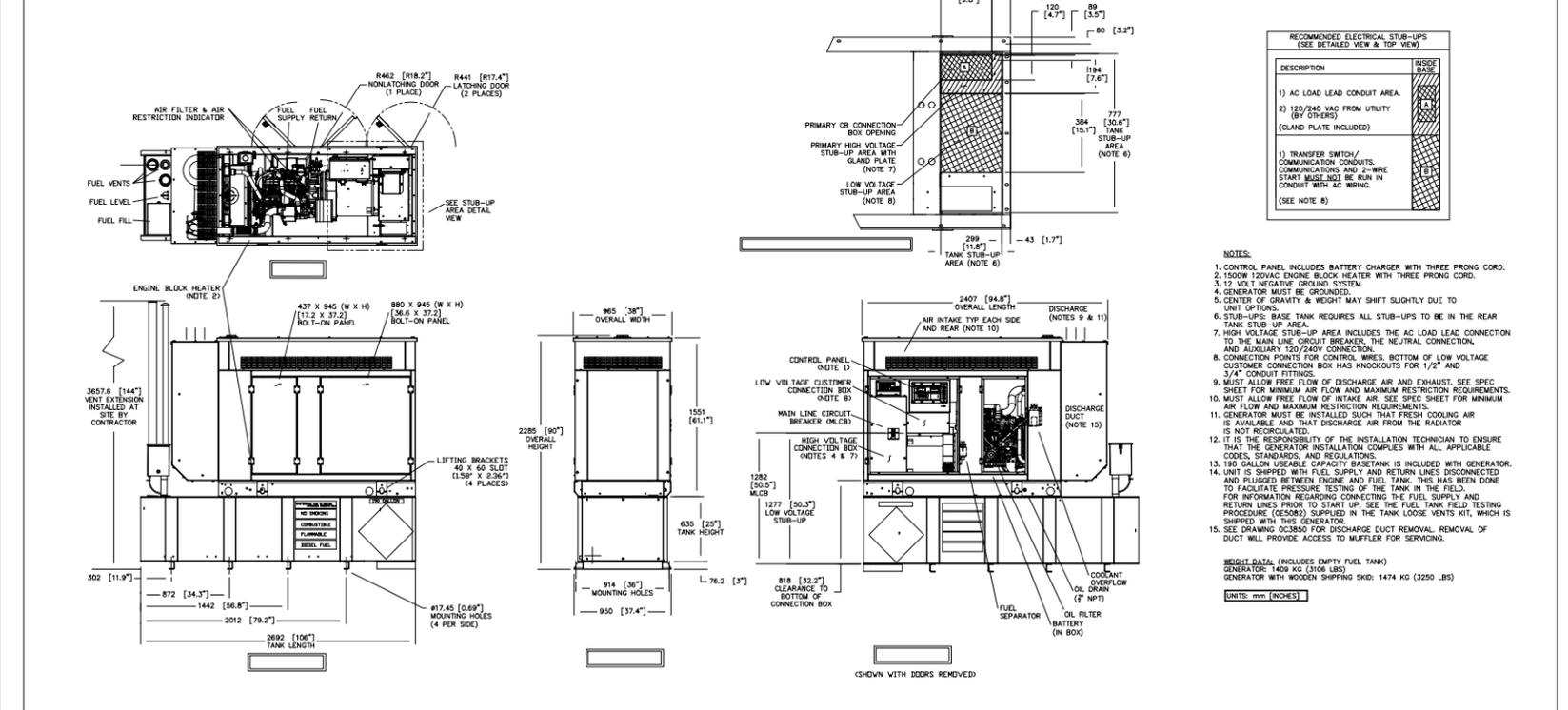

INSTALLATION DRAWING

INSTALL SD030 DIESEL 2.4L G16 L2A Y02 SSM 190 GAL EXT VNT/FILL BASETANK		GENERAC POWER SYSTEMS Waukesha P.O. BOX 8 WAUKESHA, WIS. 53187	
FILE NAME	SIZE B	SCALE	FIRST USE CALIFORNIA
DWG NO.	REV A		
OJ7500D			

SD030 GENERATOR INSTALLATION DRAWING

SCALE: NONE 4

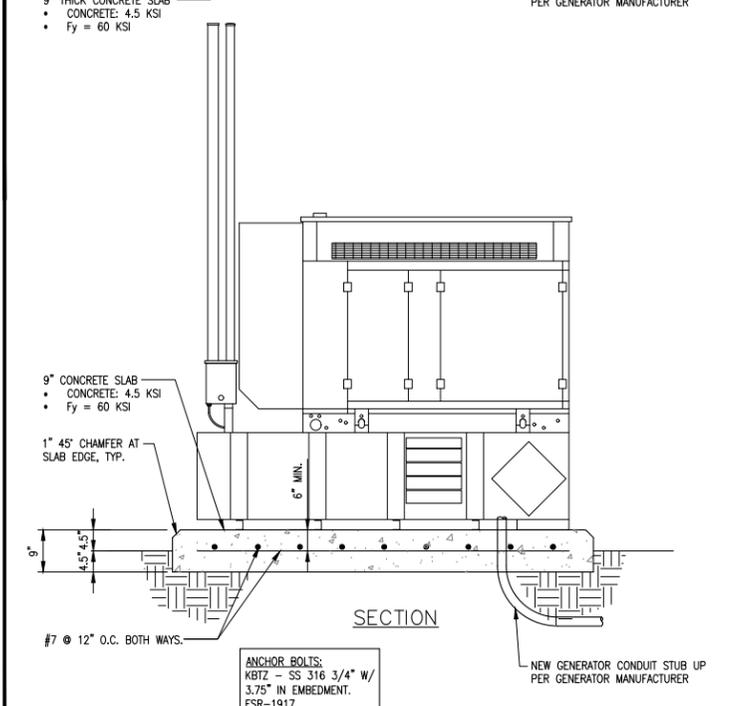
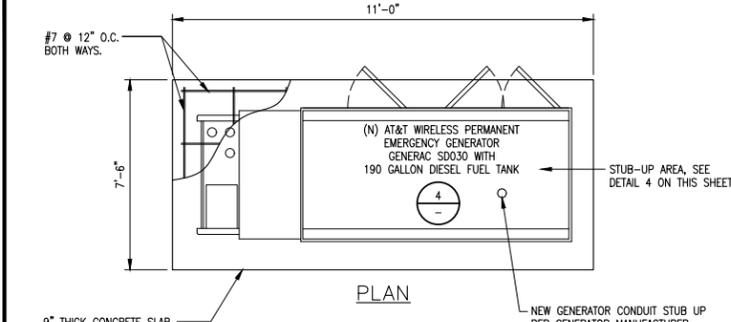

GENERATOR ON CONCRETE SLAB

SCALE: NONE 2

INFINIGY ENGINEERING, LLP

26455 RANCHO PARKWAY SOUTH
 LAKE FOREST, CALIFORNIA 92630
 JOB NUMBER 469-001

REV	DATE	DESCRIPTION
3	06/19/19	CHANGE TO MONOPOLE
2	05/16/19	90% CONSTRUCTION DRAWINGS
1	04/26/19	90% CONSTRUCTION DRAWINGS
0	04/17/19	90% CONSTRUCTION DRAWINGS

IT IS A VIOLATION OF LAW FOR ANY PERSON, UNLESS THEY ARE ACTING UNDER THE DIRECTION OF A LICENSED PROFESSIONAL ENGINEER, TO ALTER THIS DOCUMENT.

CCL04830
 CUERVO HOLDINGS
 51500 PINE CANYON
 KING CITY, CA 93930
 TOWER/CWIC

SHEET TITLE
EQUIPMENT SPECS & DETAILS

SHEET NUMBER
D-3

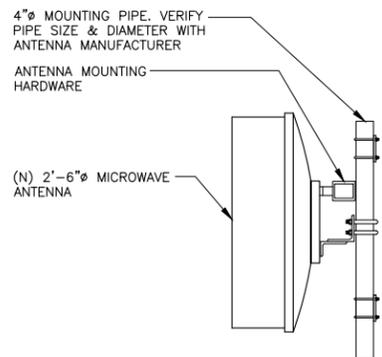

MICROWAVE DISH DETAIL

SCALE: NONE 4

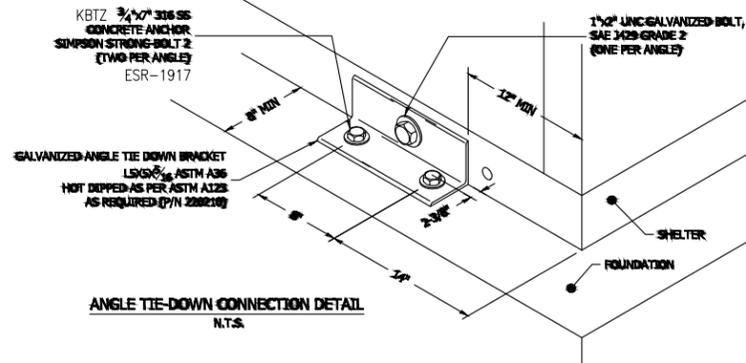

SHELTER TIE DOWN DETAILS

NO SCALE 2

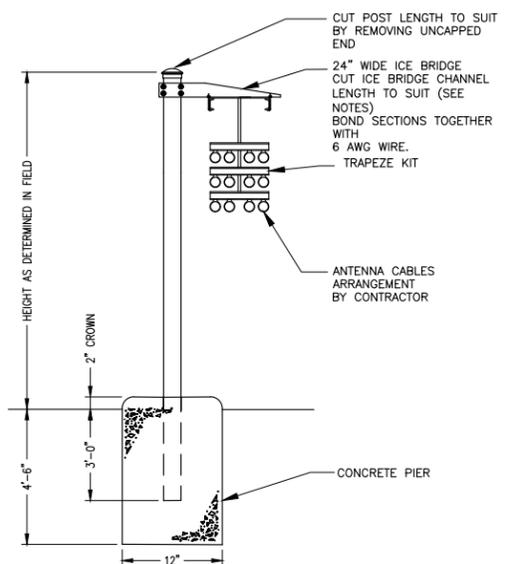
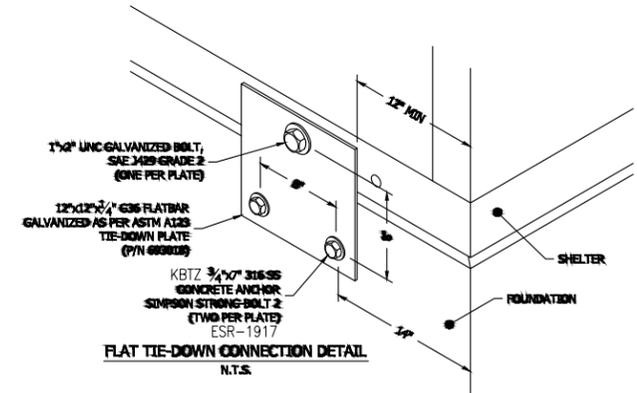

- NOTES:
1. WHEN USING COMPONENTS AS SHOWN IN STANDARD DETAILS, MAXIMUM ALLOWABLE SPAN BETWEEN SUPPORTS ON A CONTINUOUS SINGLE SECTION OF BRIDGE CHANNEL SHALL BE 9 FEET FOR 10 FEET BRIDGE CHANNEL.
 2. WHEN USING COMPONENTS FOR SPLICING BRIDGE CHANNEL SECTIONS, THE SPLICE SHOULD BE PROVIDED AT THE SUPPORT, IF POSSIBLE, OR AT A MAXIMUM OF 2 FEET FROM THE SUPPORT.
 3. WHEN USING COMPONENTS, SUPPORT SHOULD BE PROVIDED AS CLOSE AS POSSIBLE TO THE ENDS OF ICE BRIDGES, WITH A MAXIMUM CANTILEVER DISTANCE OF 2 FEET FROM THE SUPPORT TO THE FREE END OF THE ICE BRIDGE.
 4. CUT BRIDGE CHANNEL SECTIONS SHALL HAVE RAW EDGES TREATED WITH A MATERIAL TO RESTORE THESE EDGES TO THE ORIGINAL CHANNEL, OR EQUIVALENT, FINISH.
 5. ICE BRIDGES MAY BE CONSTRUCTED WITH COMPONENTS FROM OTHER MANUFACTURERS, PROVIDED THE MANUFACTURER'S INSTALLATION GUIDELINES ARE FOLLOWED.
 6. DEVIATIONS FROM STANDARDS FOR COMPONENT INSTALLATIONS ARE PERMITTED WITH THE RESPECTIVE MANUFACTURER'S APPROVAL.
 7. DEVIATIONS FROM ICE BRIDGE FOUNDATIONS REQUIRE ENGINEERING APPROVAL.
 8. THE DESIGN IS BASED ON ASCE 7-98, 3 SECOND GUST WIND SPEED OF 110 MPH, EXPOSURE C, ELEVATION AT GRADE.
 9. THIS DESIGN IS BASED ON 24" WIDE ICE BRIDGE AND (12) 1 5/8" DIA COAX CABLES AND MAX. POST SUPPORT SPACING OF 10'-0".

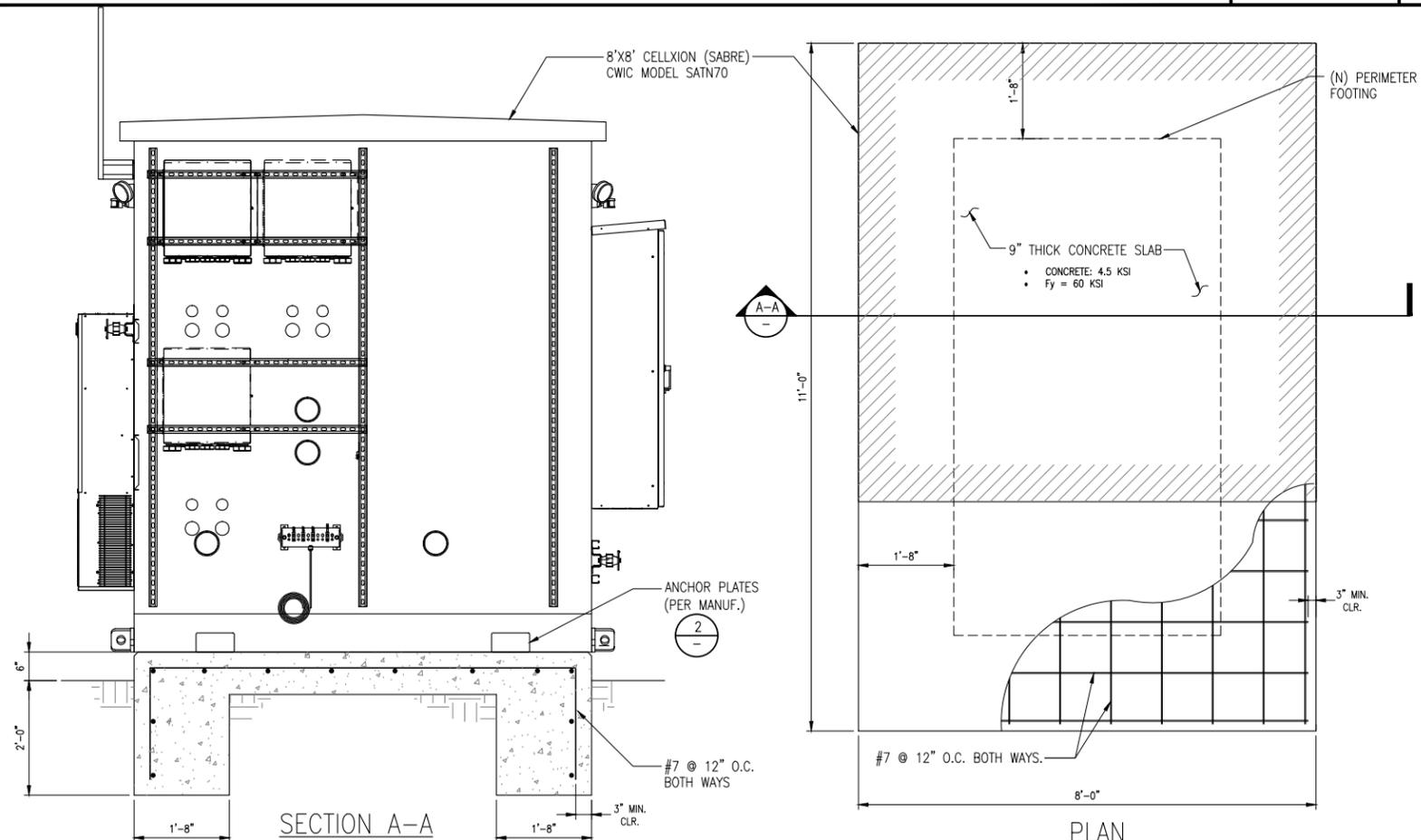

- NOTES:
1. ALL CONCRETE SHALL HAVE A MINIMUM COMPRESSIVE STRENGTH OF 4500 PSI AT 28 DAYS WITH TYPE V CEMENT AND A CEMENT/WATER RATIO OF 0.45 OR LESS
 2. ALL CONCRETE SHALL BE CONSOLIDATED BY INTERNAL VIBRATION IN ACCORDANCE WITH A.C.I. STANDARDS 309-72 RECOMMENDED PRACTICE FOR CONSOLIDATION OF CONCRETE.
 3. ALL COLD WEATHER/HOT WEATHER CONCRETE PLACEMENT SHALL BE IN ACCORDANCE WITH A.C.I. 305 AND 306.
 4. FOUNDATION FOR SHELTER BASED ON 1500PSF (MIN) BEARING VALUE. PER THE 2016 C.B.C.
 5. PROVIDE CONCRETE TEST CYLINDERS: 1 AT 7 DAYS, 2 AT 28 DAYS. SUBMIT TEST DATA TO CONSTRUCTION MANAGER FOR REVIEW & APPROVAL.
 6. SAWCUT AND REMOVE INTERFERING PAVEMENT AS NECESSARY FOR FOUNDATION CONSTRUCTION.
 7. PLACE 6 MIL VISQUEEN MOISTURE BARRIER AND COVER WITH 2" OF CLEAN SAND.
- REINFORCING STEEL:
1. ALL REINFORCING STEEL SHALL BE ASTM A615 GRADE 60 BARS
 2. ALL DETAILING, FABRICATION, PLACING AND SUPPORTS SHALL BE IN ACCORDANCE WITH A.C.I. 318-89 AND C.R.S.I.

ANCHOR BOLTS:
KBTZ - SS 316 3/4" W/
3.75" IN EMBEDMENT.
ESR-1917

CONTRACTOR TO VERIFY AND
COORDINATE PROPER GRADE WITH
CONSTRUCTION MANAGER



5001 EXECUTIVE PKWY
SAN RAMON, CA 94583



575 LENNON LANE, SUITE 125
WALNUT CREEK, CA 94598



26455 RANCHO PARKWAY SOUTH
LAKE FOREST, CALIFORNIA 92630
JOB NUMBER 469-001

REV	DATE	DESCRIPTION
3	06/19/19	CHANGE TO MONOPOLE
2	05/16/19	90% CONSTRUCTION DRAWINGS
1	04/26/19	90% CONSTRUCTION DRAWINGS
0	04/17/19	90% CONSTRUCTION DRAWINGS

IT IS A VIOLATION OF LAW FOR ANY PERSON,
UNLESS THEY ARE ACTING UNDER THE DIRECTION
OF A LICENSED PROFESSIONAL ENGINEER,
TO ALTER THIS DOCUMENT.

CCL04830
CUERVO HOLDINGS
51500 PINE CANYON
KING CITY, CA 93930
TOWER/CWIC

SHEET TITLE
EQUIPMENT SPECS
& DETAILS

SHEET NUMBER

D-4

ICE BRIDGE W/ BURIAL POSTS

SCALE: NONE 3

CWIC ON CONC PAD

SCALE: NONE 1

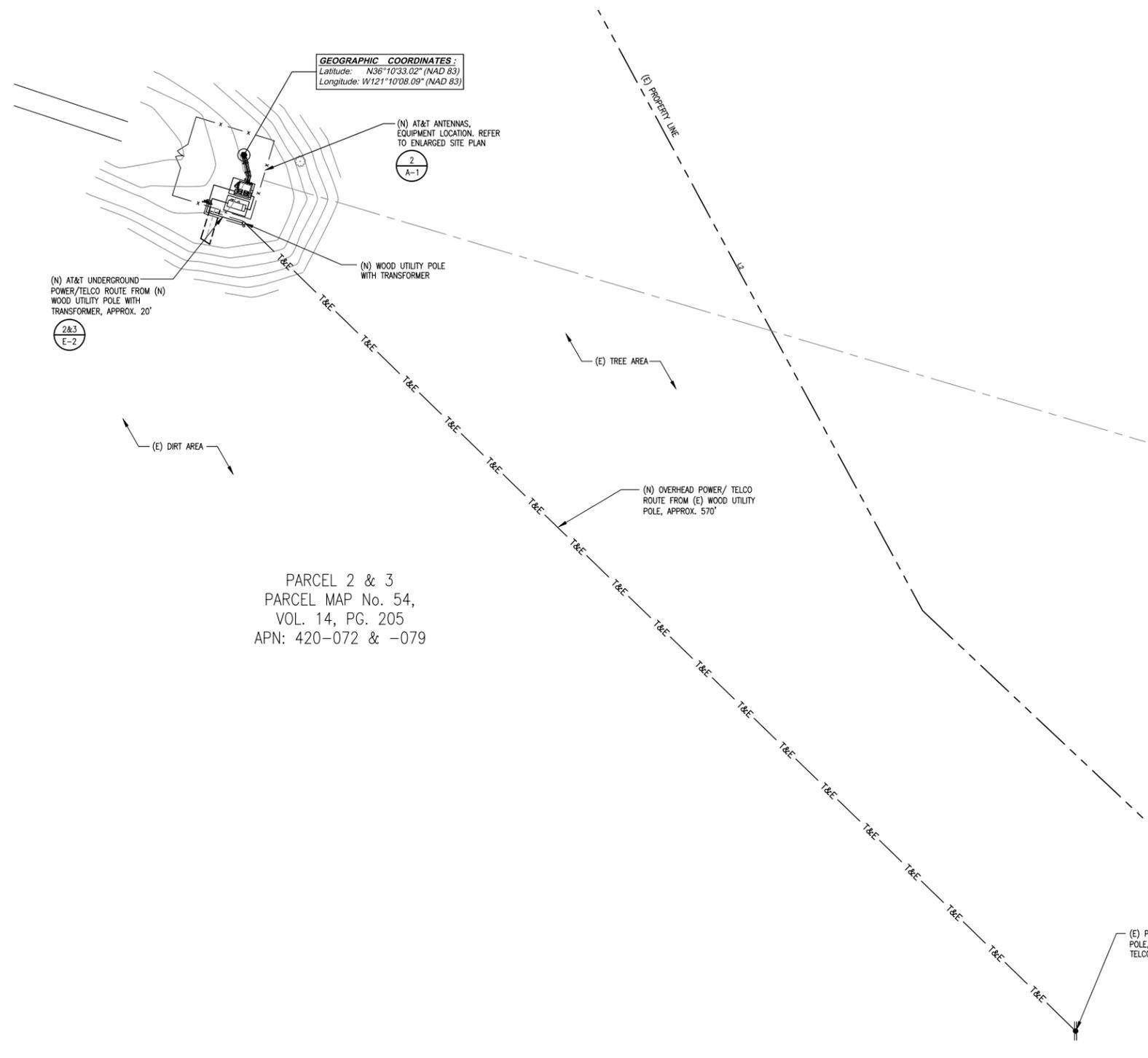

PARCEL 2 & 3
 PARCEL MAP No. 54,
 VOL. 14, PG. 205
 APN: 420-072 & -079

NOTES

1. THE CONDUIT ROUTING ARE DIAGRAMMATICALLY SHOWN ON THE PLANS AND ARE ONLY APPROXIMATIONS. THE EXACT LOCATION AND ROUTING SHALL BE FIELD VERIFIED.
2. ALL ELECTRICAL EQUIPMENT AND CONTROLLING DEVICES SHALL BE PROVIDED WITH ENGRAVED LAMICOID NAMEPLATES, INDICATING THE CIRCUITS ORIGIN AND ALL EQUIPMENT TERMINATIONS.
3. SUBCONTRACTOR SHALL PROVIDE STRAIN-RELIEF AND CABLE SUPPORTS FOR ALL CABLE ASSEMBLIES, COAX CABLES, AND RET CONTROL CABLES. CABLE STRAIN-RELIEFS, CABLE SUPPORTS SHALL BE APPROVED FOR THE PURPOSE. INSTALLATION SHALL BE IN ACCORDANCE WITH THE MANUFACTURER'S SPECIFICATIONS AND RECOMMENDATIONS.
4. SUBCONTRACTOR SHALL PROVIDE ALL BREAKERS, CONDUITS, CABLE TRAY, AND CIRCUIT CONDUCTORS, AS REQUIRED FOR A COMPLETED SYSTEM AND SHALL BE IN COMPLIANCE WITH THE MANUFACTURER'S SPECIFICATIONS.

ABBREVIATIONS

- AC ALTERNATING CURRENT
- AIC AMPERAGE INTERRUPTION CAPACITY
- ATS AUTOMATIC TRANSFER SWITCH
- AWG AMERICAN WIRE GAUGE
- BTC BARE TINNED COPPER CONDUCTOR
- BATT BATTERY
- CHG CHARGING
- COMM COMMON
- DC DIRECT CURRENT
- DIA DIAMETER
- DWG DRAWING
- EC ELECTRICAL CONDUCTOR
- EMT ELECTRICAL METALLIC TUBING
- FIF FACILITY INTERFACE FRAME
- GEN GENERATOR
- GPS GLOBAL POSITIONING SYSTEM
- HVAC HEAT/VENTILATION/AIR CONDITIONING
- IGR INTERIOR GROUNDING RING (HALO)
- MGB MASTER GROUNDING BAR
- MIN MINIMUM
- M/W MICROWAVE
- MTS MANUAL TRANSFER SWITCH
- NEC NATIONAL ELECTRICAL CODE
- OC ON CENTER
- PP POLARIZING PRESERVING
- PCU PRIMARY CONTROL UNIT
- PDU PROTOCOL DATA UNIT
- RECT RECTIFIER
- RMC RIGID METALLIC CONDUIT
- RRH REMOTE RADIO HEAD
- RWY RACEWAY
- SIAD SMART INTEGRATED ACCESS DEVICE
- TVSS TRANSIENT VOLTAGE SUPPRESSION SYSTEM
- TYP TYPICAL
- UMTS UNIVERSAL MOBILE TELECOMMUNICATION SYSTEM
- UPS UNINTERRUPTIBLE POWER SOURCE (DC POWER PLANT)



5001 EXECUTIVE PKWY
 SAN RAMON, CA 94583



575 LENNON LANE, SUITE 125
 WALNUT CREEK, CA 94598



26455 RANCHO PARKWAY SOUTH
 LAKE FOREST, CALIFORNIA 92630
 JOB NUMBER 469-001

REV	DATE	DESCRIPTION
3	06/19/19	CHANGE TO MONOPOLE
2	05/16/19	90% CONSTRUCTION DRAWINGS
1	04/26/19	90% CONSTRUCTION DRAWINGS
0	04/17/19	90% CONSTRUCTION DRAWINGS

IT IS A VIOLATION OF LAW FOR ANY PERSON, UNLESS THEY ARE ACTING UNDER THE DIRECTION OF A LICENSED PROFESSIONAL ENGINEER, TO ALTER THIS DOCUMENT.

CCL04830
 CUERVO HOLDINGS
 51500 PINE CANYON
 KING CITY, CA 93930
 TOWER/CWIC

SHEET TITLE
**ELECTRICAL
 SITE PLAN**

SHEET NUMBER
E-1

ELECTRICAL SITE PLAN

SCALE:
 1" = 30' - 0"
 0 15' 30' 1

OVERHEAD POWER — OHP — OHP — OHP — OHP —	OVERHEAD UTILITIES — OHU — OHU — OHU — OHU —	UNDERGROUND DUCT — UGD — UGD — UGD — UGD —	ABOVE GROUND TELCO — AGT — AGT — AGT — AGT —
UNDERGROUND POWER — UGP — UGP — UGP — UGP —	UNDERGROUND TELCO — UGT — UGT — UGT — UGT —	ABOVE GROUND POWER — AGP — AGP — AGP — AGP —	ABOVE GROUND TELCO/POWER — AGT/P — AGT/P —

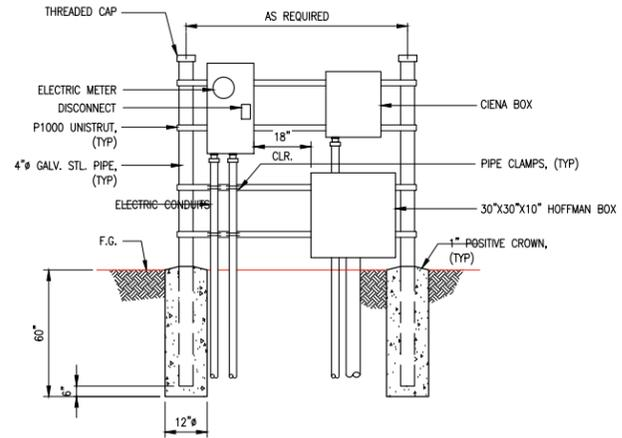

UTILITY H-FRAME

NO SCALE 5

PANEL 'A' SCHEDULE											
120/240V, 1 PHASE, 3W						INTERSECT # MP1220042-3R-B					
200A BUS, 42 KAIC						200A MAIN BKR (COMMERCIAL PWR) 42 KAIC SERIES RATED					
UL LISTED SERVICE ENTRANCE EQUIPMENT											
MAIN BREAKER RATING (A): 200						SYSTEM VOLTAGE (V): 240					
DESCRIPTION	VA	chc	BKR	POSN	L1	L2	POSN	BKR	chc	VA	DESCRIPTION
RECTIFIER #1	1752	NC	30	1	1802	2	15	C	50	150	SMOKE DETECTOR
	1752	NC	30	3	1902	4	20	C	150	150	LIGHTING
RECTIFIER #2	1752	NC	30	5	2472	6	20	NC	720	720	CONV OUTLETS
	1752	NC	30	7	1902	8	15	NC	150	150	EMERGENCY LTG
RECTIFIER #3	1752	NC	30	9	3496	10	40	NC	1744	1744	HVAC #1
	1752	NC	30	11	3496	12	40	NC	1744	1744	HVAC #1
RECTIFIER #4	1752	NC	30	13	2247	14	15	NC	495	495	FCU #1
	1752	NC	30	15	2247	16	15	NC	495	495	FCU #1
RECTIFIER #5	1752	NC	30	17	1752	18	40	NC	0	0	HVAC #2 (NOTE 2)
	1752	NC	30	19	1752	20	40	NC	0	0	HVAC #2 (NOTE 2)
RECTIFIER #6	1752	NC	30	21	1752	22	15	NC	0	0	FCU #2 (NOTE 2)
	1752	NC	30	23	1752	24	15	NC	0	0	FCU #2 (NOTE 2)
RECTIFIER #7	1752	NC	30	25	1932	26	15	NC	180	180	G.F.I. (W.P.)
	1752	NC	30	27	2232	28	20	NC	480	480	GEN BAT CHARGER
SPACE				29	600	30	20	NC	600	600	GENERATOR HEATER
				31	0	32					SPACE
				33	0	34					SPACE
				35	0	36					SPACE
				37	0	38					SPACE
				39	0	40					SPACE
				41	0	42	30	NC	-	-	SURGE ARRESTOR
PHASE TOTALS (VA):					16053	15243					
CURRENT PER PHASE (A):					129	123	Amperes/phase cannot exceed main breaker rating				
PANEL TOTAL (VA):					30256						
PANEL CAPACITY (kVA):					48.0						
PANEL LOADING (100% non-cont. load) (kVA):					30.1						
PANEL LOADING (125% continuous load) (kVA):					0.3						
PANEL LOADING (TOTAL) (kVA):					30.4						
SPARE CAPACITY (kVA):					17.6						

NOTES:
 1. MAIN (COMMERCIAL) BREAKER IS SQUARE D # QGL22200 WHICH IS RATED 65 KAIC. BRANCH BREAKERS SHALL BE SQUARE D TYPE QO RATED 10 KAIC. ALL BREAKERS PROVIDED BY GC.
 2. REDUNDANT AICs INTERLOCKED WITH LEAD-LAG CONTROLLER TO PREVENT SIMULTANEOUS OPERATION OF BOTH SYSTEMS. (OMIT FROM OPERATING LOAD)
 3. LIGHTING ARE DESIGNED & INSTALLED BY WIC MANUFACTURER
 4. PROVIDE ARC FLASHING WARNING MARKING PER CEC 110.16

PANEL SCHEDULE

NO SCALE 6

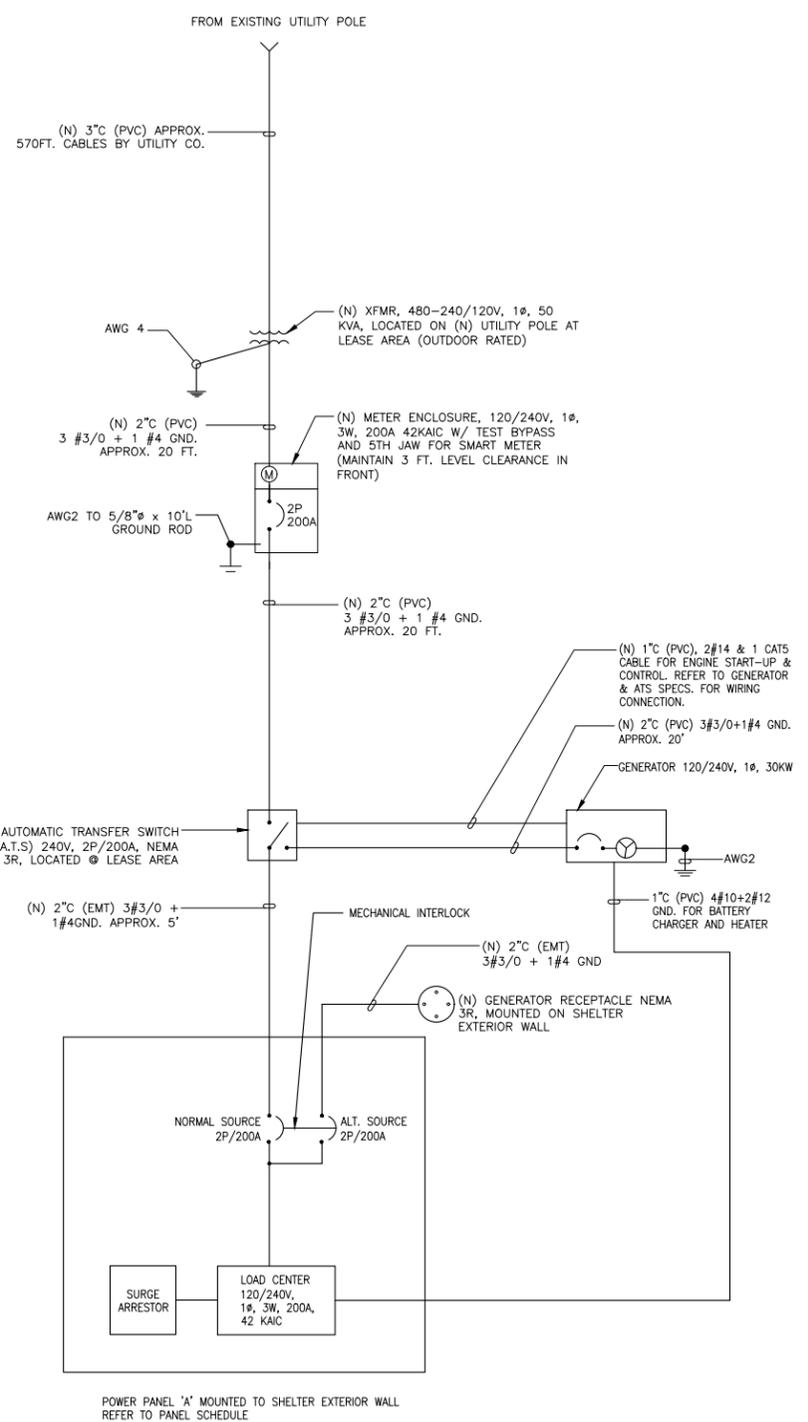

SINGLE LINE DIAGRAM

NO SCALE 4

ELECTRICAL GENERAL NOTES

1. THE ELECTRICAL CONTRACTOR SHALL PAY ALL ELECTRICAL FEES FOR PERMITS, AND BE RESPONSIBLE FOR OBTAINING SAID PERMITS AND COORDINATING ALL ELECTRICAL INSPECTIONS.
2. ALL ELECTRICAL WORK SHALL CONFORM TO THE REQUIREMENTS SET FORTH IN THE N.E.C. IN ADDITION TO ALL APPLICABLE LOCAL CODES.
3. ALL ELECTRICAL COMPONENTS SHALL BE U.L. LISTED.
4. CONTRACTOR SHALL EXAMINE ALL GENERAL CONSTRUCTION DRAWINGS AND VISIT CONSTRUCTION SITE TO BE FAMILIAR WITH EXISTING CONDITIONS UNDER WHICH THEY WILL HAVE TO OPERATE AND WHICH WILL IN ANY WAY AFFECT THE WORK UNDER THIS CONTRACT.
5. PROVIDE A PULL ROPE AND GREENLEE CONDUIT MEASURING TAPE IN TELEPHONE CONDUIT FOR BTS #1 REGARDLESS OF WHETHER CABLE IS INSTALLED OR NOT.
6. ALL PANELS, DISCONNECT SWITCHES, ETC. SHALL BE SUPPLIED WITH A LOCKABLE DEVICE PER AT&T REQUIREMENTS.
7. WET RATED CONDUCTORS SHALL BE USED FOR UNDERGROUND LOCATIONS.

NOTES

1

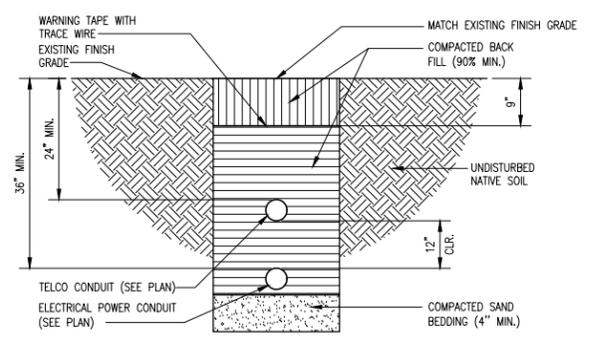

JOINT TRENCH DETAIL

2

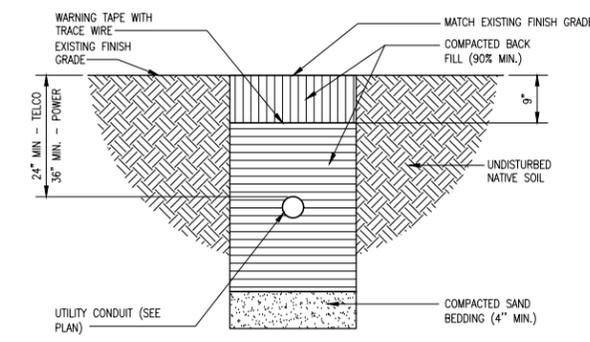

TRENCH DETAIL

NO SCALE 3



5001 EXECUTIVE PKWY
SAN RAMON, CA 94583



575 LENNON LANE, SUITE 125
WALNUT CREEK, CA 94598



26455 RANCHO PARKWAY SOUTH
LAKE FOREST, CALIFORNIA 92630
JOB NUMBER 469-001

REV	DATE	DESCRIPTION
3	06/19/19	CHANGE TO MONOPOLE
2	05/16/19	90% CONSTRUCTION DRAWINGS
1	04/26/19	90% CONSTRUCTION DRAWINGS
0	04/17/19	90% CONSTRUCTION DRAWINGS

IT IS A VIOLATION OF LAW FOR ANY PERSON, UNLESS THEY ARE ACTING UNDER THE DIRECTION OF A LICENSED PROFESSIONAL ENGINEER, TO ALTER THIS DOCUMENT.

CCL04830
CUERVO HOLDINGS
51500 PINE CANYON
KING CITY, CA 93930
TOWER/CWIC

SHEET TITLE
SINGLE LINE DIAGRAM,
PANEL SCHEDULE, NOTES
& DETAILS

SHEET NUMBER
E-2

ALL WORK SHALL BE IN ACCORDANCE TO THE AT&T GROUNDING STANDARDS MORE SPECIFICALLY, ALL CONNECTIONS SHALL BE MADE WITH AN EXOTHERMIC WELD PROCESS. WHERE EXOTHERMIC WELDS ARE NOT POSSIBLE, A 2-HOLE COMPRESSION TYP LUG IS PERMITTED

SYMBOL LEGEND
 ■ EXOTHERMIC CONNECTION
 ▲ MECHANICAL CONNECTION

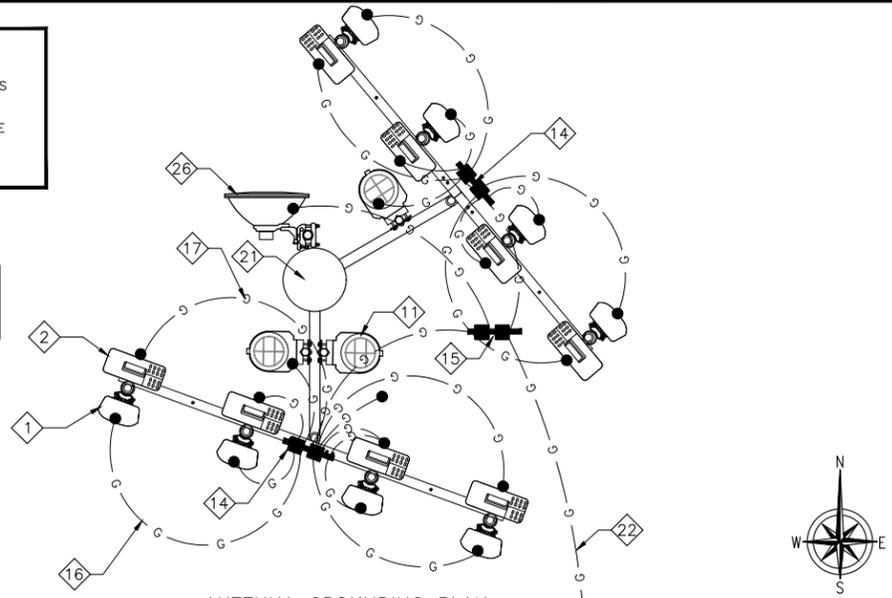

ANTENNA GROUNDING PLAN

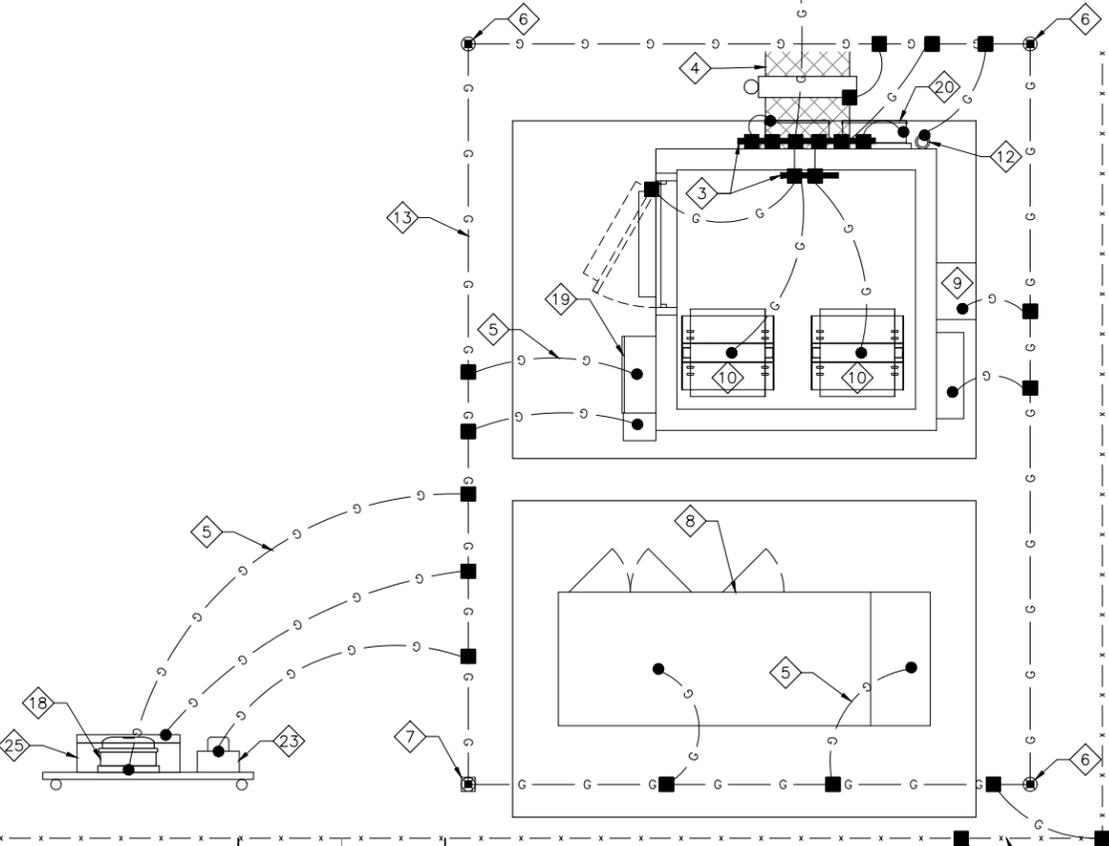

EQUIPMENT GROUNDING PLAN

GENERAL NOTES:

1. PLAN DRAWINGS SHOWN HEREIN ARE DIAGRAMMATIC AND DOES NOT NECESSARILY DEPICT THE EXACT EQUIPMENT QUANTITIES, LOCATION, LAYOUT AND CONFIGURATION. REFER TO ARCHITECTURAL PLANS FOR EXACT EQUIPMENT LOCATION, LAYOUT AND CONFIGURATION.
2. PLAN DRAWINGS SHOWN HEREIN DO NOT NECESSARILY DEPICT ELECTRICAL REQUIREMENTS OF INDIVIDUAL EQUIPMENT AND DEVICES SUCH AS THE EQUIPMENT GROUNDING REQUIREMENTS, POWER REQUIREMENTS AND TELCO RACEWAY REQUIREMENTS.
3. REFER TO ARCHITECTURAL PLANS FOR THE LOCATION OF POWER AND TELCO POINT OF CONNECTIONS, THE DISTANCE OF THE RUN AND THE SUGGESTED CONDUIT ROUTING. FIELD VERIFY EXISTING CONDITIONS SPECIFICALLY FOR CONDUIT ROUTING PRIOR TO BID.
4. ALL NEW GROUNDING WORK SHALL BE IN ACCORDANCE TO THE AT&T GROUNDING STANDARDS

KEY NOTES

- 1 (N) AT&T PANEL ANTENNAS
- 2 (N) AT&T RRU'S
- 3 (N) MASTER GROUND BUS BARS AT SHELTER
- 4 (N) CABLE ICE BRIDGE
- 5 #2 AWG BARE COPPER WIRE (UNLESS OTHERWISE SPECIFIED).
- 6 GROUND ROD
- 7 GROUND TEST WELL
- 8 (N) 30KW DIESEL GENERATOR
- 9 (N) HVAC UNIT
- 10 (N) EQUIPMENT RACK LOCATED INSIDE CWIC (WALK IN CABINET)
- 11 (N) DC-6 SURGE SUPPRESSOR
- 12 (N) GPS ANTENNA
- 13 (N) GROUND RING AWG #2 BARE STRANDED COPPER WIRE BURIED 30" BELOW GRADE
- 14 ANTENNA GROUND BAR AT EACH SECTOR
- 15 ANTENNA GROUND BUS BAR AT TOP AND BOTTOM OF TOWER
- 16 #6 AWG INSULATED, COPPER WIRE FROM ANTENNA GROUND KIT TO ANTENNA GROUND BAR
- 17 #2 AWG INSULATED, COPPER WIRE (UNLESS OTHERWISE SPECIFIED) FROM RRU, DC6 TO ANTENNA GROUND BAR
- 18 (N) CIENNA BOX
- 19 (N) AT&T 200A ATS
- 20 (N) (2) AT&T DC12 MOUNTED ON CWIC WALL EXTERIOR
- 21 (N) TOWER
- 22 (N) AWG2 INSULATED COPPER GROUND WIRE FROM ANTENNA GROUND BAR @ BOTTOM OF POLE TO MASTER GROUND BUS BAR @ SHELTER
- 23 (N) METER MOUNTED ON H-FRAME
- 24 (N) CHAIN LINK FENCE/ GATES
- 25 (N) 30"x30"x10" HOFFMAN BOX
- 26 (N) MICROWAVE DISH
- 27 (N) AT&T WOOD UTILITY POLE WITH TRANSFORMER

LEGEND

- MECHANICAL CONNECTION
- EXOTHERMIC WELD (CADWELD/THERMOWELD) CONNECTION.
- ⊗ 5/8"Ø x 10'-0" COPPER, OR COPPER CLAD STEEL GROUND ROD AT 10'-0" O.C. (MAX)
- ⊗ GROUND ROD INSPECTION WELL
- G- #2 OR #6 AWG BARE COPPER

KEY NOTES & LEGEND

1. COMPRESSION CONNECTIONS (2), 2 AWG BARE TINNED SOLID COPPER CONDUCTORS TO GROUNDING BAR. ROUTE CONDUCTORS TO BURIED GROUNDING RING AND PROVIDE PARALLEL EXOTHERMIC WELD.
2. ZEC SHALL USE PERMANENT MARKER TO DRAW THE LINES BETWEEN EACH SECTION AND LABEL EACH SECTION ("P", "A", "N", "I") WITH 1" HIGH LETTERS.
3. ALL HARDWARE 18-8 STAINLESS STEEL, INCLUDING LOCK WASHERS, COAT ALL SURFACES WITH AN ANTI-OXIDANT COMPOUND BEFORE MATING. ALL HARDWARE SHALL BE STAINLESS STEEL 3/8" INCH DIAMETER OR LARGER.
4. FOR GROUND BOND TO STEEL ONLY: INSERT A CADMIUM FLAT WASHER BETWEEN LUG AND STEEL, COAT ALL SURFACES WITH AN ANTI-OXIDANT COMPOUND BEFORE MATING.
5. NUT & WASHER SHALL BE PLACED ON THE FRONT SIDE OF THE GROUNDING BAR AND BOLTED ON THE BACK SIDE. INSTALL BLACK HEAT-SHRINKING TUBE, 600 VOLT INSULATION, ON ALL GROUNDING TERMINATIONS. THE INTENT IS TO WEATHERPROOF THE COMPRESSION CONNECTION.
6. NUMBER OF GROUNDING BARS MAY VARY DEPENDING ON THE TYPE OF TOWER, ANTENNA LOCATION, AND CONNECTION ORIENTATION. PROVIDE AS REQUIRED.
7. GROUNDING KIT SHALL BE TYPE AND PART NUMBER AS SUPPLIED OR RECOMMENDED BY CABLE MANUFACTURER.
8. WEATHERPROOFING SHALL BE TYPE AND PART NUMBER AS SUPPLIED OR RECOMMENDED BY CABLE MANUFACTURER.
9. SUPPLIED AND INSTALLED BY CONTRACTOR.
10. WHEN THE SCOPE OF WORK REQUIRES THE ADDITION OF A GROUNDING BAR TO AN EXISTING TOWER, THE SUBCONTRACTOR SHALL OBTAIN APPROVAL FROM THE TOWER OWNER PRIOR TO MOUNTING THE GROUNDING BAR TO THE TOWER.
11. EXTEND TWO (2) 2 AWG TINNED CU CONDUCTOR FROM BURIED GROUNDING RING AND CONNECT TO THE PROPOSED TOWER. FOLLOW MANUFACTURER'S RECOMMENDATIONS FOR GROUNDING CONNECTIONS TO THE TOWER. (APPLICABLE TO NEW TOWERS ONLY.)
12. NUMBER OF GROUNDING BARS MAY VARY DEPENDING ON THE TYPE OF TOWER, ANTENNA LOCATION, AND CONNECTION ORIENTATION. THE SUBCONTRACTOR SHALL BE RESPONSIBLE FOR INSTALLING ADDITIONAL GROUNDING BARS AS REQUIRED, PROVIDING 50% SPARE CONNECTION POINTS.
13. BUILDINGS AND/OR NEW TOWERS GREATER THAN 75 FEET IN HEIGHT AND THE MAIN GROUNDING CONDUCTORS ARE REQUIRED TO BE ROUTED TO GRADE. THE SUBCONTRACTOR SHALL ROUTE TWO GROUNDING CONDUCTORS FROM THE ROOFTOP, TOWERS, AND WATER TOWERS GROUNDING RING, TO THE EXISTING GROUNDING SYSTEM. THE GROUNDING CONDUCTORS SHALL NOT BE SMALLER THAN 2/0 AWG COPPER. ROOFTOP GROUNDING RING SHALL BE BONDED TO THE EXISTING GROUNDING SYSTEM, THE BUILDING STEEL COLUMNS, LIGHTNING PROTECTION SYSTEM, AND BUILDING MAIN WATER LINE (FERROUS OR NONFERROUS METAL PIPING ONLY). SEE AT&T GROUNDING AND BONDING STANDARDS TP-76416 SPECIFICATION 6.3.2.2.
14. ALL GROUNDING BARS SHALL BE STAMPED IN TO THE METAL "IF STOLEN DO NOT RECYCLE." THE SUBCONTRACTOR SHALL USE PERMANENT MARKER TO DRAW THE LINES BETWEEN EACH SECTION AND LABEL EACH SECTION ("P", "A", "N", "I") WITH 1" HIGH LETTERS.
15. THE SUBCONTRACTOR SHALL BE RESPONSIBLE TO PROVIDE TWO APPROVED "FALL OF POTENTIAL" TESTS. THE FIRST, WILL BE CONDUCTED PRIOR TO MAKING CONNECTIONS AND THE SECOND WILL BE CONDUCTED AFTER THE FINAL CONNECTIONS HAVE BEEN MADE TO PROPOSED EQUIPMENT. THE SUPPLEMENTAL GROUNDING SYSTEM, AND THE EXISTING GROUNDING SYSTEM, THESE TESTS SHALL BE PERFORMED BY A QUALIFIED AND CERTIFIED TESTING AGENT. PROVIDE INDEPENDENT TEST RESULTS TO THE PROJECT MANAGER FOR REVIEW. THE GROUNDING SYSTEM RESISTANCE TO EARTH GROUNDING SHALL NOT EXCEED (5) OHMS. IF THE GROUNDING TEST EXCEEDS THE MAXIMUM OF (5) OHMS, THE SUBCONTRACTOR SHALL BE RESPONSIBLE TO PROVIDE ADDITIONAL GROUNDING RODS AND CONNECTIONS AS REQUIRED TO MEET THE (5) OHMS' MAXIMUM.
16. THE INSPECTOR HAVING JURISDICTION SHALL INSPECT ALL GROUNDING CONNECTIONS FOR TIGHTNESS. EXOTHERMIC WELDED CONNECTIONS SHALL BE APPROVED BEFORE BEING PERMANENTLY CONCEALED.
17. FOR ALL CONNECTIONS TO THE GROUNDING RING, SEE THE SHELTER MANUFACTURER'S DRAWINGS.
18. WHEN AN EXISTING METER RACK IS BEING UTILIZED AND A NEW METER IS INSTALLED IN THE EXISTING METER RACK, THE GROUNDING ROD, AND GROUNDING CONDUCTORS OF THE EXISTING GROUNDING RING SHALL BE EXTENDED TO THE PROPOSED GROUNDING RING AND BECOME A COMPLETE GROUNDING SYSTEM.
19. FOR ROOFTOP INSTALLATIONS, ROUTE GROUNDING CONDUCTORS ON THE SHELTER'S EXTERIOR SUPPORTING STRUCTURE. WHEN A SUPPORT PLATFORM STRUCTURE IS EMPLOYED, ROUTE GROUNDING CONDUCTORS UNDERNEATH AND ON THE SUPPORTING MEMBERS, USING APPROVED STRAPS OR SCHEDULE 40 PVC CONDUITS AS REQUIRED IN ARTICLE 6.4.1.7.
20. FOR GROUNDING INSTALLATIONS, WHICH HAVE A LIMITED AREA AND ARE REQUIRED TO BE INSTALLED WITHIN THE LEASE AREA ONLY, THE GROUNDING RING CONDUCTORS CAN BE INSTALLED UNDER THE SHELTER'S FOOTINGS.
21. SUBCONTRACTOR SHALL PROVIDE STRAIN-RELIEF AND CABLE SUPPORTS FOR ALL CABLE ASSEMBLIES, COAX CABLES, AND RET CONTROL CABLES. CABLE STRAIN-RELIEFS AND CABLE SUPPORTS SHALL BE APPROVED FOR THE PURPOSE. INSTALLATION SHALL BE IN ACCORDANCE WITH MANUFACTURER'S SPECIFICATIONS AND RECOMMENDATIONS.
22. SUBCONTRACTOR SHALL GROUND ALL EQUIPMENT, INCLUDING ANTENNAS, RET MOTORS, TMA'S, COAX CABLES, AND RET CONTROL CABLES AS A COMPLETE SYSTEM. GROUNDING SHALL BE EXECUTED BY QUALIFIED WIREMEN IN COMPLIANCE WITH MANUFACTURER'S SPECIFICATIONS AND RECOMMENDATIONS.

SCALE: 1/2"=1'-0" 0 1 2' 2



REV	DATE	DESCRIPTION
3	06/19/19	CHANGE TO MONOPOLE
2	05/16/19	90% CONSTRUCTION DRAWINGS
1	04/26/19	90% CONSTRUCTION DRAWINGS
0	04/17/19	90% CONSTRUCTION DRAWINGS

IT IS A VIOLATION OF LAW FOR ANY PERSON, UNLESS THEY ARE ACTING UNDER THE DIRECTION OF A LICENSED PROFESSIONAL ENGINEER, TO ALTER THIS DOCUMENT.

CCL04830
 CUERVO HOLDINGS
 51500 PINE CANYON
 KING CITY, CA 93930
 TOWER/CWIC

SHEET TITLE
 GROUNDING LAYOUT, KEY NOTES, LEGEND & DETAILS

SHEET NUMBER
 G-1

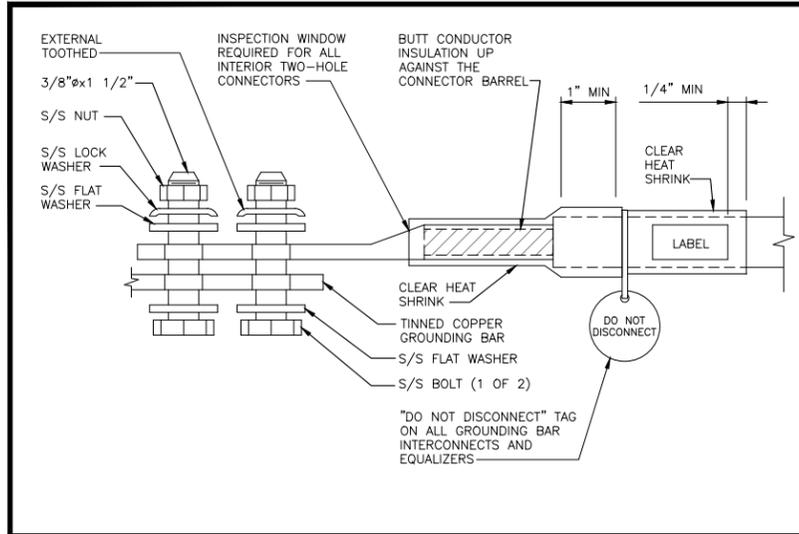

INTERIOR TWO HOLE LUG

NO SCALE

1

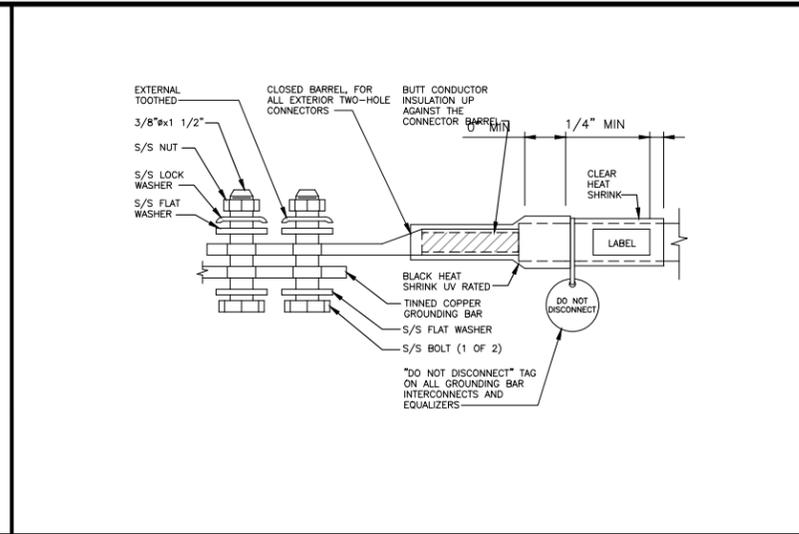

EXTERIOR TWO HOLE LUG

NO SCALE

2

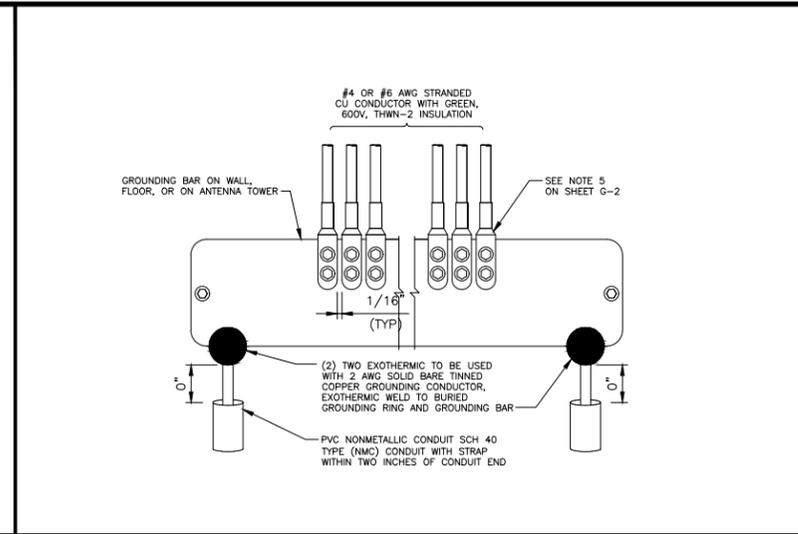

INSTALLATION OF GROUNDING CONDUCTOR TO GROUNDING BAR

NO SCALE

3

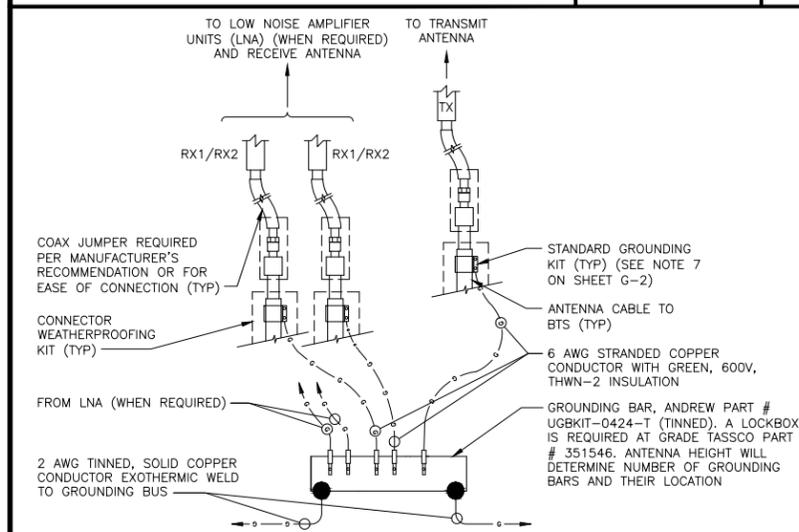

ANTENNA GROUNDING BAR

NO SCALE

4

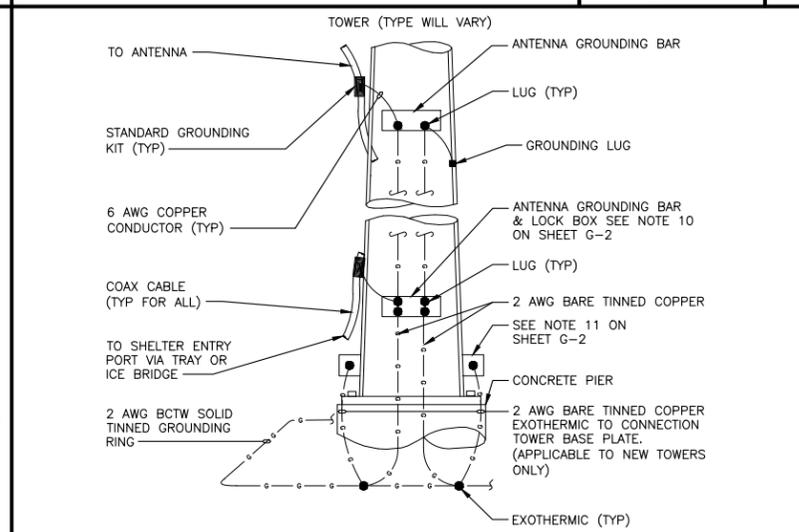

ANTENNA CABLE GROUNDING

NO SCALE

5

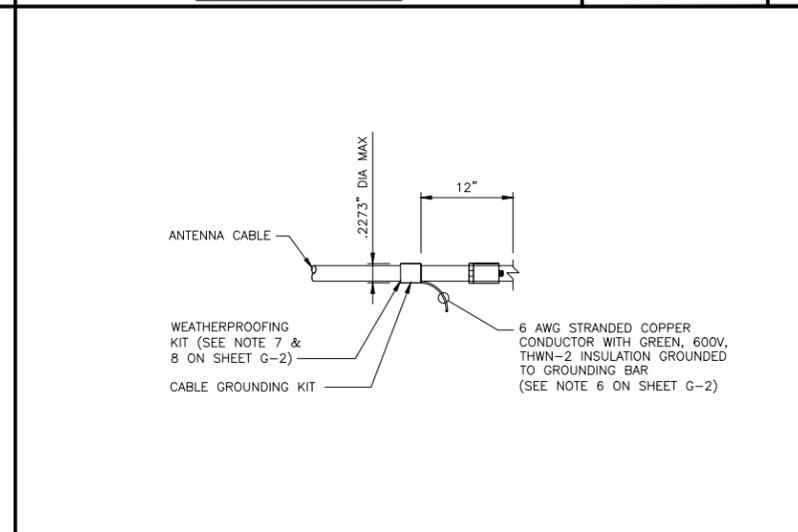

CONNECTION OF CABLE GROUNDING KIT TO ANTENNA CABLE

NO SCALE

6

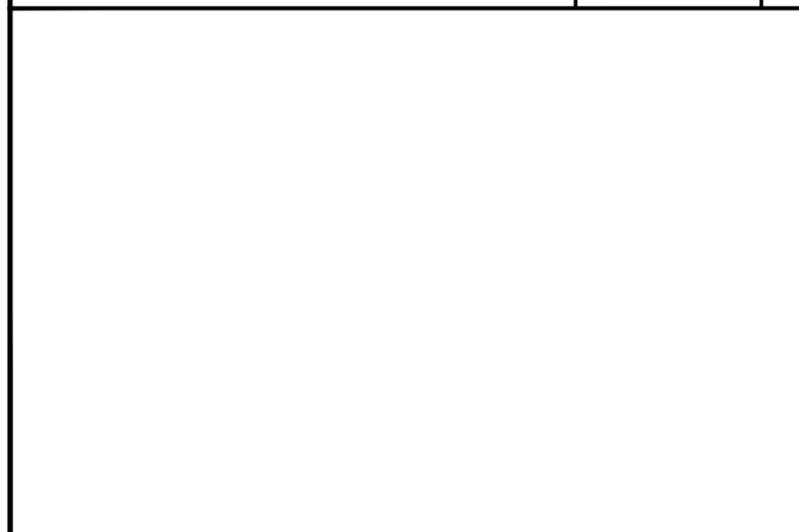

NOT USED

NO SCALE

7



NOT USED

NO SCALE

8

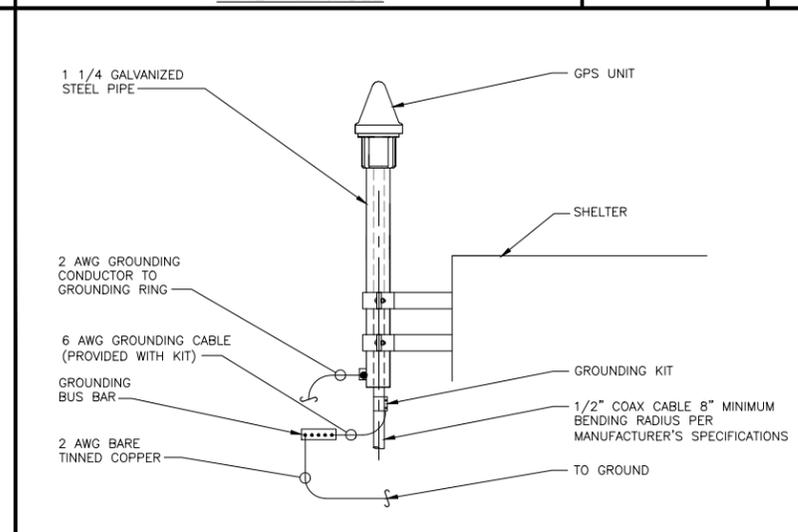

GPS GROUNDING

NO SCALE

9

5001 EXECUTIVE PKWY
SAN RAMON, CA 94583

575 LENNON LANE, SUITE 125
WALNUT CREEK, CA 94598

INFINIGY
ENGINEERING, LLP

26455 RANCHO PARKWAY SOUTH
LAKE FOREST, CALIFORNIA 92630

JOB NUMBER 469-001

REV	DATE	DESCRIPTION
3	06/19/19	CHANGE TO MONOPOLE
2	05/16/19	90% CONSTRUCTION DRAWINGS
1	04/26/19	90% CONSTRUCTION DRAWINGS
0	04/17/19	90% CONSTRUCTION DRAWINGS

IT IS A VIOLATION OF LAW FOR ANY PERSON, UNLESS THEY ARE ACTING UNDER THE DIRECTION OF A LICENSED PROFESSIONAL ENGINEER, TO ALTER THIS DOCUMENT.

CCL04830
CUERVO HOLDINGS
51500 PINE CANYON
KING CITY, CA 93930
TOWER/CWIC

SHEET TITLE
GROUNDING DETAILS
& NOTES

SHEET NUMBER
G-2