

# Exhibit A

This page intentionally left blank.



**MONTEREY COUNTY  
HOUSING AND COMMUNITY DEVELOPMENT**

HOUSING, PLANNING, BUILDING, ENGINEERING, ENVIRONMENTAL SERVICES  
1441 Schilling Place, South 2<sup>nd</sup> Floor (831)755-5025  
Salinas, California 93901-4527 www.co.monterey.ca.us

**INLAND DESIGN APPROVAL APPLICATION FORM**

ASSESSOR'S PARCEL NUMBER: 416-261-023-000

PROJECT ADDRESS: 148 San Benancio Road

PROPERTY OWNER: Courtland Evers Telephone: 831 601-6678  
Address: POBox 1749 Fax: \_\_\_\_\_  
City/State/Zip: Monterey, CA 93942 Email: courtlandevers@gmail.com

APPLICANT: Darren Davis Telephone: 831 646-5986  
Address: 2150 Garden Road, B3 Fax: \_\_\_\_\_  
City/State/Zip: Monterey, CA 93940 Email: darren@draftect.com

AGENT: same as applicant Telephone: \_\_\_\_\_  
Address: \_\_\_\_\_ Fax: \_\_\_\_\_  
City/State/Zip: \_\_\_\_\_ Email: \_\_\_\_\_

Mail Notices to:  Owner  Applicant  Agent  
(Check only one)

**PROJECT DESCRIPTION:** New 2 story SFD w/ 1991 s.f. main floor, 13711 s.f. unfinished lower floor, 720 sf. Attached garage, 123 s.f. covered front porch, 386 s.f. deck, 1670 s.f. driveway, dvm't on 25% slopes 496 s.f. (11% of development), 2-5000 gal water tanks q/ 240 s.f. shed roof. Cut 62 c.y., Fill 97 c.y.

**MATERIALS TO BE USED:** Hardie Panel Board and Batt siding, Trex decking, Stainless Steel cable guardrail, Alum Clad windows.

**COLORS TO BE USED:** Roof: GAF Barkwood, Body: Sherwin Williams #SW704 Snowbound, Trim, Fascia, Windows: Sherwin Williams #SW7041 Van Dyke Brown, Deck: Redwood Trex

I acknowledge that I will need a building permit and must comply with the Monterey County Building Ordinance and that this approval is for design of the structures and compliance with zoning regulations only. For properties served by Onsite Wastewater Treatment System (OWTS), the Environmental Health Bureau (EHB) will not review this application but may need to require redesign of the project in the subsequent construction permit application to address impacts related to the existing OWTS or future standby area. A project redesign may require a subsequent Design Approval application and additional fees.

PROPERTY OWNER/AGENT SIGNATURE: [Signature] DATE: 9-3-2024  
REV. 12-3-2025

**FOR DEPARTMENT USE ONLY**

ZONING: \_\_\_\_\_ AREA PLAN: \_\_\_\_\_  
ADVISORY COMMITTEE: \_\_\_\_\_ RELATED PERMITS: \_\_\_\_\_  
PLANNER: \_\_\_\_\_  
WITHIN ARCH BUFFER ZONE?  YES  NO ON SEPTIC SYSTEM (OWTS)?  YES  NO  
LEGAL LOT: \_\_\_\_\_  YES  NO DOES THIS CORRECT A VIOLATION?  YES  NO

**FINDINGS:**  
 The project is consistent with the 2010 General Plan, the applicable Area Plan, and meets the regulations in Title 21 (Zoning Ordinance-Inland); and  
 The design of the proposed project assures protection of the public viewshed, is consistent with neighborhood character, and assures visual integrity without imposing undue restrictions on private property because: \_\_\_\_\_

DECISION:  OVER-THE-COUNTER  ADMINISTRATIVE  
ACTION:  APPROVED  DENIED  
CONDITIONS:  ATTACHED  NONE  
APPROVED BY: \_\_\_\_\_ DATE: \_\_\_\_\_  
COPY TO APPLICANT:  IN PERSON OR  MAILED DATE: \_\_\_\_\_

## General Plan Policy Consistency Checklist For Design Approvals (Inland Only) To Be Completed By Applicants

PLN 240262

<b>Land Use Designation:</b> <div style="text-align: center; font-size: 1.2em; font-weight: bold;">LDR/5-D</div>	<b>AD#: 416-261-023-000</b>	<b>Planning Number:</b> <div style="text-align: center; font-size: 1.2em; font-weight: bold;">DA240218</div>
<b>Area Plan:</b> <input type="checkbox"/> Cachagua Area Plan <input type="checkbox"/> Carmel Valley Master Plan <input type="checkbox"/> Central Salinas Valley Area Plan <input type="checkbox"/> Fort Ord Master Plan <input type="checkbox"/> Greater Monterey Peninsula Area Plan <input type="checkbox"/> Greater Salinas Area Plan <input type="checkbox"/> North County Area Plan <input type="checkbox"/> South County Area Plan <input checked="" type="checkbox"/> Toro Area Plan <input type="checkbox"/> Agriculture & Winery Corridor Plan	<b>Project Description:</b> New 2 story SFD w/ 1991 s.f. main floor, 13711 s.f. unfinished lower floor, 720 sf. Attached garage, 123 s.f. covered front porch, 386 s.f. deck, 1670 s.f. driveway, dvm't on 25% slopes 496 s.f. (11% of development), 2- 5000 gal water tanks q/ 240 s.f. shed roof. Cut 62 c.y., Fill 97 c.y.	

Please Answer Each Question Based On The Description Of The Project (See Back Of Questionnaire For Policy References)	
	*The Project Is For: <input checked="" type="checkbox"/> Residential <input type="checkbox"/> Commercial <input type="checkbox"/> Agricultural <input type="checkbox"/> Public Or Quasi-Public <input type="checkbox"/> Industrial Use
<input type="checkbox"/> Yes <input checked="" type="checkbox"/> No	The Project Proposes A Cell-Site, Telecom (Digital) Communication Facility/Site?
<input checked="" type="checkbox"/> Yes <input type="checkbox"/> No	The Project Includes The Construction Of A New Structure?
<input type="checkbox"/> Yes <input checked="" type="checkbox"/> No	The Project Includes The Enlarging, Altering, Repairing, Moving, Improving, Or Removing Of Existing Structures? If "Yes", Describe _____
<input type="checkbox"/> Yes <input checked="" type="checkbox"/> No	The Project Includes Demolition Work? If "Yes", Describe _____
<input type="checkbox"/> Yes <input checked="" type="checkbox"/> No	Project Includes The Use Of Roofing Materials That Are Different In Type and/or Color From The Original Materials?
<input type="checkbox"/> Yes <input checked="" type="checkbox"/> No	Project Includes Replacement and/or Repair Of (50%) Or More Of The Exterior Walls Of A Structure?
<input type="checkbox"/> Yes <input checked="" type="checkbox"/> No	Project Includes Historical Structure Or A Structure More Than Fifty (50) Years Old?
<input type="checkbox"/> Yes <input checked="" type="checkbox"/> No	Project Includes An Accessory Structure(S)? If "Yes", Describe: _____
<input type="checkbox"/> Yes <input checked="" type="checkbox"/> No	Project Includes The Placement Of A Manufactured Home, Mobile Home, Modular Or Prefabricated Unit? <input type="checkbox"/> Private Property <input type="checkbox"/> Park Installation _____ (Mobile Home Park)
<input type="checkbox"/> Yes <input checked="" type="checkbox"/> No	Project Includes Retaining Walls?
<input type="checkbox"/> Yes <input checked="" type="checkbox"/> No	Project Involves New, Change Or Modifications To Existing Utilities and/or Power Lines?
<input type="checkbox"/> Yes <input checked="" type="checkbox"/> No	Project Is Change Or Modification To An Approved Application.
<input type="checkbox"/> Yes <input checked="" type="checkbox"/> No	Does The Project Propose A Lot Line Adjustment Or Subdivision?
<input type="checkbox"/> Yes <input checked="" type="checkbox"/> No	Does The Project Include Subdivision Creating Five Or More Lots, Or New Commercial/Industrial Use That Creates Intensity Equal To Or Greater Than Five Residences?
<input type="checkbox"/> Yes <input checked="" type="checkbox"/> No	Is The Project Located Near An Incorporated Area (City)?
<input type="checkbox"/> Yes <input checked="" type="checkbox"/> No	Is The Project Located Within A Community Area Or Rural Center?
<input type="checkbox"/> Yes <input checked="" type="checkbox"/> No	Is The Project Located Within ¼ Mile Of A Public Airport?
<input checked="" type="checkbox"/> Yes <input type="checkbox"/> No	Is This The First Residence On A Property?
<input type="checkbox"/> Yes <input checked="" type="checkbox"/> No	Does The Project Propose A Secondary Unit?
<input type="checkbox"/> Yes <input checked="" type="checkbox"/> No	Would Native Vegetation Be Removed With This Project?
<input type="checkbox"/> Yes <input checked="" type="checkbox"/> No	Would Proposed Development Occur Within 100 Feet A Creek/Drainage (Including Seasonal) Or River? <span style="margin-left: 150px;">SEPARATE PERMIT</span>
<input type="checkbox"/> Yes <input checked="" type="checkbox"/> No	Does The Project Propose Any Tree Removal? If "Yes" Type _____ Size _____ Number _____
<input type="checkbox"/> Yes <input type="checkbox"/> No	Project Includes Grading, Dirt Importation, Dirt Removal, And/or Drainage Changes.
<input checked="" type="checkbox"/> Yes <input type="checkbox"/> No	Would The Project Be Connected To An Existing Well Or Private Water System?
<input type="checkbox"/> Yes <input checked="" type="checkbox"/> No	The Project Includes Constructing, Enlarging, Altering, Repairing, Moving, Improving Or Removing A Well.
<input type="checkbox"/> Yes <input checked="" type="checkbox"/> No	Project Is Associated With A New Or Improvements To A Water System. _____ Water System _____ Number of Connections
<input checked="" type="checkbox"/> Yes <input type="checkbox"/> No	Does The Project Include A New Individual Or Existing Wastewater System (E.G. Septic)?
<input checked="" type="checkbox"/> Yes <input type="checkbox"/> No	The Project Includes Constructing, Enlarging, Altering, Repairing, Moving, Improving Or Removing A Septic Tank/System?
<input type="checkbox"/> Yes <input type="checkbox"/> No	Does The Project Propose Development On Slopes Over 25%?
<input type="checkbox"/> Yes <input checked="" type="checkbox"/> No	Is The Project 50 Feet From A Bluff?
<input type="checkbox"/> Yes <input type="checkbox"/> No	Project Is Located Within 100 Feet Of Seasonal Or Permanent Drainage, Lake, Marsh, Ocean, Pond, Slough, Stream, Wetlands. If "Yes", Describe _____
<input type="checkbox"/> Yes <input checked="" type="checkbox"/> No	Does The Project Include Cultivation Of Land That Is Currently Not Cultivated?
<input type="checkbox"/> Yes <input checked="" type="checkbox"/> No	Does The Project Propose Non-Agricultural Uses Adjacent To Agricultural Uses?
<input type="checkbox"/> Yes <input checked="" type="checkbox"/> No	Is The Project Located Within The Winery Corridor?
<input type="checkbox"/> Yes <input type="checkbox"/> No	Would Any Portion Of The Proposed Development Be Visible From A Public Road, Designated Vista Point, Or Public Park? If Yes, Is It Located On A Slope Or Near The Top Of A Hill? Yes _____ No _____

<input type="checkbox"/> Yes <input checked="" type="checkbox"/> No	Does The Project Propose Or Require Affordable Housing?
<input type="checkbox"/> Yes <input checked="" type="checkbox"/> No	Does The Project Require A General Plan Amendment?
<input type="checkbox"/> Yes <input checked="" type="checkbox"/> No	Is The Project Located Within A Special Treatment Area?
<input type="checkbox"/> Yes <input checked="" type="checkbox"/> No	Is The Project Located Within A Study Area?
<input type="checkbox"/> Yes <input checked="" type="checkbox"/> No	Project Involves Or Includes An Existing Or Proposed Trail Or Easement.

I, The Undersigned, Have Authority To Submit Application For A Permit On The Subject Property. I Have Completed This Questionnaire Accurately Based On The Proposed Project Description. It Is My Interpretation That The Project Is Consistent With The 2010 Monterey County General Plan. I Understand That Monterey County May Require Project Changes Or Some Other Permit/Entitlement If The Project Is Found To Be Inconsistent With Any General Plan Policy.

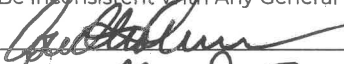
Signature:  OWNER Date: 7/24/2024  
 Print Name: Carl Alair Ewers

**Please remember to provide photos, colors, and materials, as these are mandatory.**

This page intentionally left blank

# DRAFT RESOLUTION

## Before the Zoning Administrator in and for the County of Monterey, State of California

In the matter of the application of:

**EVERS COURTLAND F TR (PLN240262)**

**RESOLUTION NO. 26-**

Resolution by the Monterey County Zoning  
Administrator:

- 1) Finding that the project qualifies as a Class 3 Categorical Exemption pursuant to Section 15303 of the CEQA Guidelines and there are no exceptions pursuant to Section 15300.2; and
- 2) Approving a Design Approval to allow the construction of a two-story 1,991 square foot single-family dwelling with 1,371 square foot unfinished basement, 720 square foot attached garage, and associated site improvements including 509 square feet of covered porches and decks, (2) five-thousand gallon water tanks, and a 1,670 square foot driveway.

[PLN240262] [Courtland Evers], [148 San Benancio, Salinas], [Toro Area Plan] (Assessor's Parcel Number 416-261-023-000)]

**The EVERS application (PLN240262) came on for a public hearing before the Monterey County Zoning Administrator on April 30, 2026. Having considered all the written and documentary evidence, the administrative record, the staff report, oral testimony, and other evidence presented, the Zoning Administrator finds and decides as follows:**

### RECITALS

**WHEREAS**, the proposed project PLN240262, located at 148 San Benancio Road, Salinas, Toro Area Plan. (APN: 416-261-023-000), is consistent with the policies of the Monterey County 2010 General Plan, Toro Area Plan, and the Monterey County Zoning Ordinance (Title 21);

**WHEREAS**, the subject parcel is zoned Low Density Residential, with 5 acres per unit density, and Design Control overlay which allows for construction of a single-family dwelling and accessory structures, subject to the granting of a Design Approval pursuant to Chapter 21.44;

**WHEREAS**, as proposed, the project consists of construction to allow a new two-story 1,991 square foot single-family dwelling with 1,371 square foot unfinished basement, 720 square foot attached garage, and associated site improvements including 509 square feet of covered porches and decks, (2) five-thousand gallon water tanks, and a 1,670 square foot driveway.

**WHEREAS**, as detailed in the attached plans, the proposed project meets all required development standards established in Monterey County Code (MCC) Section 21.14.060.C and 2010 General Plan Policy LU-2.2, (see attached plans);

**WHEREAS**, as proposed, the project includes 394 square feet of development on slopes exceeding 25 percent, and the development on slopes does not exceed ten percent (10%), or 500 square feet of the total development footprint (whichever is less), a Use Permit shall not be required, and therefore is consistent with Open Space Policy 3.5 of the 2010 General Plan;

**WHEREAS**, the proposed colors and materials consist of light cream board and batten siding with brown roofing materials, and natural redwood decking and guardrails. The colors and materials, and bulk and mass blend with the surrounding environment, are consistent with the surrounding residential neighborhood character, and other dwellings in the neighborhood;

**WHEREAS**, the proposed project is not located in an area of high visual sensitivity and as sited, designed, and conditioned, will not result in adverse visual impacts. Further, the project is

consistent with the applicable scenic resource policies of the 2010 General Plan and the Toro Area Plan;

**WHEREAS**, the proposed project does include the removal of 3 Coast Live Oaks (TRM260056) that are within the building footprint, and is consistent with Title 16 section 16.60.040 for the removal of 3 or less protected trees in a one-year period;

**WHEREAS**, in accordance with 2010 General Plan Policy and MCC Section 21.66.050, a Phase 1 Archaeological Report (LIB260040) was prepared. The Phase 1 Archaeological Report concluded no cultural or archaeological resources were discovered during field pedestrian survey on or about the project site. Therefore, County standard Condition No. 3 has been added to require construction be halted in the event resources are uncovered at the site, to allow an archaeological evaluate and determine appropriate next measures;

**WHEREAS**, the subject property (5 acres) is identified as Parcel 1 (Document No. 2018040207) of Volume 36 Page 4 in Record of Survey, recorded April 5, 2022, and is therefore recognized by the County as legal lot of record;

**WHEREAS**, Monterey County HCD-Planning and HCD-Building Services records were reviewed, and the County is not aware of any violations existing on subject property;

**WHEREAS**, the project was referred to the Toro Land Use Advisory Committee pursuant to Board of Supervisors adopted LUAC Guidelines, on March 9, 2026. The voting outcome and the LUAC minutes will be provided at hearing in a staff errata;

**WHEREAS**, California Environmental Quality Act (CEQA) Guidelines Section 15303 categorically exempts new construction of single-family dwellings and accessory structures, and as proposed the project includes construction of new two-story single-family dwelling with unfinished basement, and attached two-car garage. Therefore, the proposed development is consistent with CEQA Guidelines Section 15303 and none of the exceptions under CEQA Guidelines Section 15300.2 apply to this project; and

**WHEREAS**, pursuant to MCC Section 21.80.040.B, the Planning Commission shall consider appeals from the discretionary decisions of the Zoning Administrator and the decision of the Planning Commission would be final and may not be appealed.

**NOW, THEREFORE BE IT RESOLVED**, based on the above recitals, the Monterey County Zoning Administrator does hereby:

- 1) Find that the project qualifies as a Class 3 Categorical Exemption pursuant to Section 15303 of the CEQA Guidelines and there are no exceptions pursuant to Section 15300.2; and
- 2) Approve a Design Approval to allow the construction of a two-story 1,991 square foot single-family dwelling with 1,371 square foot unfinished basement, 720 square foot attached garage, and associated site improvements including 509 square feet of covered porches and decks, (2) five-thousand gallon water tanks, and a 1,670 square foot driveway.

**PASSED AND ADOPTED** this 30<sup>th</sup> day of April , 2026.

---

Mike Novo, Zoning Administrator

COPY OF THIS DECISION MAILED TO APPLICANT ON DATE.

THIS APPLICATION IS APPEALABLE TO THE PLANNING COMMISSION. IF ANYONE WISHES TO APPEAL THIS DECISION, AN APPEAL FORM MUST BE COMPLETED AND SUBMITTED TO THE SECRETARY OF THE PLANNING COMMISSION ALONG WITH THE APPROPRIATE FILING FEE ON OR BEFORE DATE.

This decision, if this is the final administrative decision, is subject to judicial review pursuant to California Code of Civil Procedure Sections 1094.5 and 1094.6. Any Petition for Writ of Mandate must be filed with the Court no later than the 90th day following the date on which this decision becomes final.

#### NOTES

1. You will need a building permit and must comply with the Monterey County Building Ordinance in every respect.
2. Additionally, the Zoning Ordinance provides that no building permit shall be issued, nor any use conducted, otherwise than in accordance with the conditions and terms of the permit granted or until ten days after the mailing of notice of the granting of the permit by the appropriate authority, or after granting of the permit by the Board of Supervisors in the event of appeal.
3. Do not start any construction or occupy any building until you have obtained the necessary permits and use clearances from Monterey County HCD-Planning and HCD-Building Services Department office in Salinas.

This page intentionally left blank

# County of Monterey HCD Planning

## DRAFT Conditions of Approval/Implementation Plan/Mitigation Monitoring and Reporting Plan

PLN240262

### 1. PD001 - SPECIFIC USES ONLY

**Responsible Department:** Planning

**Condition/Mitigation Monitoring Measure:** This Design Approval permit (PLN240262) allows construction of a two-story 1,991 square foot single-family dwelling with 1,371 square foot unfinished basement, 720 square foot attached garage, and associated site improvements including 509 square feet of covered porches and decks, (2) five-thousand gallon water tanks, and a 1,670 square foot driveway. The property is located at 148 San Benancio (Assessor's Parcel Number 416-261-023-000), Toro Area Plan. This permit was approved in accordance with County ordinances and land use regulations subject to the terms and conditions described in the project file. Neither the uses nor the construction allowed by this permit shall commence unless and until all of the conditions of this permit are met to the satisfaction of the Director of HCD - Planning. Any use or construction not in substantial conformance with the terms and conditions of this permit is a violation of County regulations and may result in modification or revocation of this permit and subsequent legal action. No use or construction other than that specified by this permit is allowed unless additional permits are approved by the appropriate authorities. To the extent that the County has delegated any condition compliance or mitigation monitoring to the Monterey County Water Resources Agency, the Water Resources Agency shall provide all information requested by the County and the County shall bear ultimate responsibility to ensure that conditions and mitigation measures are properly fulfilled. (HCD - Planning)

**Compliance or Monitoring Action to be Performed:** The Owner/Applicant shall adhere to conditions and uses specified in the permit on an on-going basis unless otherwise stated.

### 2. PD002 - NOTICE PERMIT APPROVAL

**Responsible Department:** Planning

**Condition/Mitigation Monitoring Measure:** The applicant shall record a Permit Approval Notice. This notice shall state:  
"A Design Approval (Resolution Number \_\_\_\_\_) was approved by Zoning Administrator for Assessor's Parcel Number 416-261-023-000 on April 30, 2026. The permit was granted subject to 7 conditions of approval which run with the land. A copy of the permit is on file with Monterey County HCD - Planning."

Proof of recordation of this notice shall be furnished to the Director of HCD - Planning prior to issuance of grading and building permits, Certificates of Compliance, or commencement of use, whichever occurs first and as applicable. (HCD - Planning)

**Compliance or Monitoring Action to be Performed:** Prior to the issuance of grading and building permits, certificates of compliance, or commencement of use, whichever occurs first and as applicable, the Owner/Applicant shall provide proof of recordation of this notice to the HCD - Planning.

### 3. PD003(A) - CULTURAL RESOURCES NEGATIVE ARCHAEOLOGICAL REPORT

**Responsible Department:** Planning

**Condition/Mitigation Monitoring Measure:** If, during the course of construction, cultural, archaeological, historical or paleontological resources are uncovered at the site (surface or subsurface resources) work shall be halted immediately within 50 meters (165 feet) of the find until a qualified professional archaeologist can evaluate it. Monterey County HCD - Planning and a qualified archaeologist (i.e., an archaeologist registered with the Register of Professional Archaeologists) shall be immediately contacted by the responsible individual present on-site. When contacted, the project planner and the archaeologist shall immediately visit the site to determine the extent of the resources and to develop proper mitigation measures required for recovery.  
(HCD - Planning)

**Compliance or Monitoring Action to be Performed:** The Owner/Applicant shall adhere to this condition on an on-going basis.

Prior to the issuance of grading or building permits and/or prior to the recordation of the final/parcel map, whichever occurs first, the Owner/Applicant shall include requirements of this condition as a note on all grading and building plans. The note shall state "Stop work within 50 meters (165 feet) of uncovered resource and contact Monterey County HCD - Planning and a qualified archaeologist immediately if cultural, archaeological, historical or paleontological resources are uncovered."

When contacted, the project planner and the archaeologist shall immediately visit the site to determine the extent of the resources and to develop proper mitigation measures required for the discovery.

### 4. PD014(A) - LIGHTING - EXTERIOR LIGHTING PLAN

**Responsible Department:** Planning

**Condition/Mitigation Monitoring Measure:** All exterior lighting shall be unobtrusive, down-lit, harmonious with the local area, and constructed or located so that only the intended area is illuminated and off-site glare is fully controlled. The lighting source shall be shielded and recessed into the fixture. The applicant shall submit three (3) copies of an exterior lighting plan which shall indicate the location, type, and wattage of all light fixtures and include catalog sheets for each fixture. The lighting shall comply with the requirements of the California Energy Code set forth in California Code of Regulations Title 24 Part 6. The exterior lighting plan shall be subject to approval by the Director of HCD - Planning, prior to the issuance of building permits.  
(HCD - Planning)

**Compliance or Monitoring Action to be Performed:** Prior to the issuance of building permits, the Owner/Applicant shall submit three copies of the lighting plans to HCD - Planning for review and approval. Approved lighting plans shall be incorporated into final building plans.

Prior to final/occupancy, the Owner/Applicant/Contractor shall submit written and photographic evidence demonstrating that the lighting has been installed according to the approved plan.

On an on-going basis, the Owner/Applicant shall ensure that the lighting is installed and maintained in accordance with the approved plan.

## 5. PW0043 - REGIONAL DEVELOPMENT IMPACT FEE

**Responsible Department:** Public Works

**Condition/Mitigation Monitoring Measure:** Prior to issuance of building permits, applicant shall pay the Regional Development Impact Fee (RDIF) pursuant to Monterey Code Chapter 12.90. The fee amount shall be determined based on the parameters adopted in the current fee schedule. Fee schedule can be found here: [https://www.tamcmonterey.org/files/53eb01ba3/2025-0701Fee\\_Implementation\\_Worksheet.xlsx](https://www.tamcmonterey.org/files/53eb01ba3/2025-0701Fee_Implementation_Worksheet.xlsx)

**Compliance or Monitoring Action to be Performed:** Prior to issuance of Building Permits Owner/Applicant shall pay Monterey County Building Services Department the traffic mitigation fee. Owner/Applicant shall submit proof of payment to the HCD-Engineering Services.

## 6. PW0045 – COUNTYWIDE TRAFFIC FEE

**Responsible Department:** Public Works

**Condition/Mitigation Monitoring Measure:** Prior to issuance of building permits, the Owner/Applicant shall pay the Countywide Traffic Fee or the ad hoc fee pursuant to General Plan Policy C-1.8. The fee amount shall be determined based on the parameters in the current fee schedule. The fee schedule can be found here: <https://www.countyofmonterey.gov/home/showpublisheddocument/138985/638884451861730000>

**Compliance or Monitoring Action to be Performed:** Prior to issuance of Building Permits, the Owner/Applicant shall pay Monterey County HCD-Building Services the traffic mitigation fee. The Owner/Applicant shall submit proof of payment to HCD-Engineering Services.

## 7. PD011 - TREE AND ROOT PROTECTION

**Responsible Department:** Planning

**Condition/Mitigation Monitoring Measure:** Trees which are located close to construction site(s) shall be protected from inadvertent damage from construction equipment by fencing off the canopy driplines and/or critical root zones (whichever is greater) with protective materials, wrapping trunks with protective materials, avoiding fill of any type against the base of the trunks and avoiding an increase in soil depth at the feeding zone or drip-line of the retained trees. Said protection, approved by certified arborist, shall be demonstrated prior to issuance of building permits subject to the approval of HCD - Director of Planning. If there is any potential for damage, all work must stop in the area and a report, with mitigation measures, shall be submitted by certified arborist. Should any additional trees not included in this permit be harmed, during grading or construction activities, in such a way where removal is required, the owner/applicant shall obtain required permits. (HCD - Planning)

**Compliance or Monitoring Action to be Performed:** Prior to issuance of grading and/or building permits, the Owner/Applicant shall submit evidence of tree protection to HCD - Planning for review and approval.

During construction, the Owner/Applicant/Arborist shall submit on-going evidence that tree protection measures are in place through out grading and construction phases. If damage is possible, submit an interim report prepared by a certified arborist.

Prior to final inspection, the Owner/Applicant shall submit photos of the trees on the property to HCD-Planning after construction to document that tree protection has been successful or if follow-up remediation or additional permits are required.

REVISIONS	BY
12-2-25	D
12-22-25	D
1-7-26	D

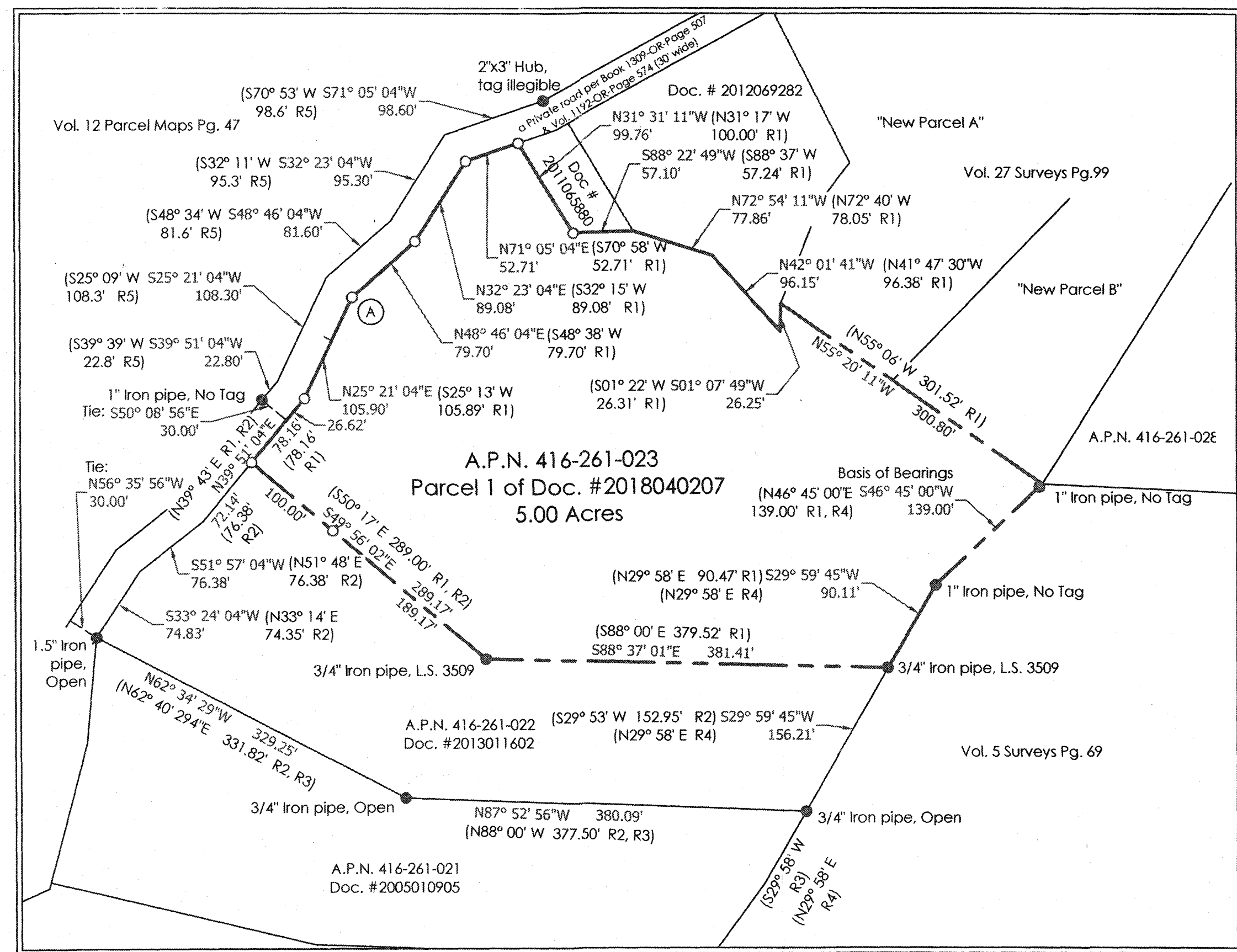

PROPERTY BOUNDARY - SCALE: 1" = 100'

**LEGEND**

- FOUND MONUMENT, AS NOTED
- SET 1" IRON PIPE TAGGED L.S. 5321, UNLESS NOTED OTHERWISE
- ⊙ WELL
- ⊗ UTILITY POLE
- GUY WIRE
- TREE, TYPE AND DIAMETER SPECIFIED
- R1 RECORD DATA PER DOCUMENT #2018040207
- R2 RECORD DATA PER DOCUMENT #2013011602
- R3 RECORD DATA PER DOCUMENT #2005010905
- R4 RECORD DATA PER VOLUME 5 OF SURVEYS AT PAGE 69
- R5 RECORD DATA PER VOLUME 12 OF PARCEL MAPS AT PAGE 47
- PROPERTY LINE
- LOT LINE
- WIRE FENCE LINE
- EDGE OF DIRT ROAD
- EDGE OF PAVEMENT
- ⓐ Found 3/4" Rebar, no tag, leaning severely replaced with 1" iron pipe, L.S. 5321
- ⓑ BENCHMARK, SET REBAR ELEVATION = 100.00'

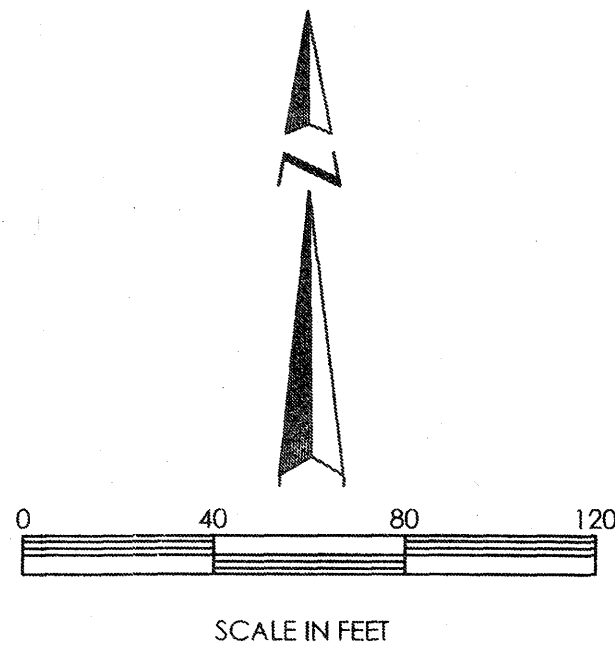

**BASIS OF BEARINGS**

THE BEARING OF S 46°45'00" W ALONG THE NORTHWESTERLY BOUNDARY LINE OF THE 5.00 ACRE PARCEL, AS SHOWN ON THE MAP RECORDED IN VOLUME 5 OF SURVEYS AT PAGE 69 AS FOUND MONUMENTED, WAS TAKEN AS BASIS OF BEARINGS SHOWN UPON THIS MAP.

**NOTES**

- DISTANCES ARE EXPRESSED IN FEET AND DECIMALS THEREOF.
- ELEVATIONS ARE BASED ON A ASSUMED DATUM. BENCHMARK TAKEN AS SET REBAR SHOWN HEREON, ELEVATION = 100.00'. CONTOUR INTERVAL = 1'.
- RECORD OF SURVEY TO BE PREPARED AND FILED WITH THE COUNTY SURVEYOR.

**SITE PLAN**  
of  
PARCEL 1 OF DOCUMENT #2018040207, OFFICIAL RECORDS OF MONTEREY COUNTY, BEING A PORTION OF THE NW 1/4 OF SECTION 12, TOWNSHIP 16 SOUTH, RANGE 2 EAST, M.D.B.&M.

1 inch = 316.84 feet

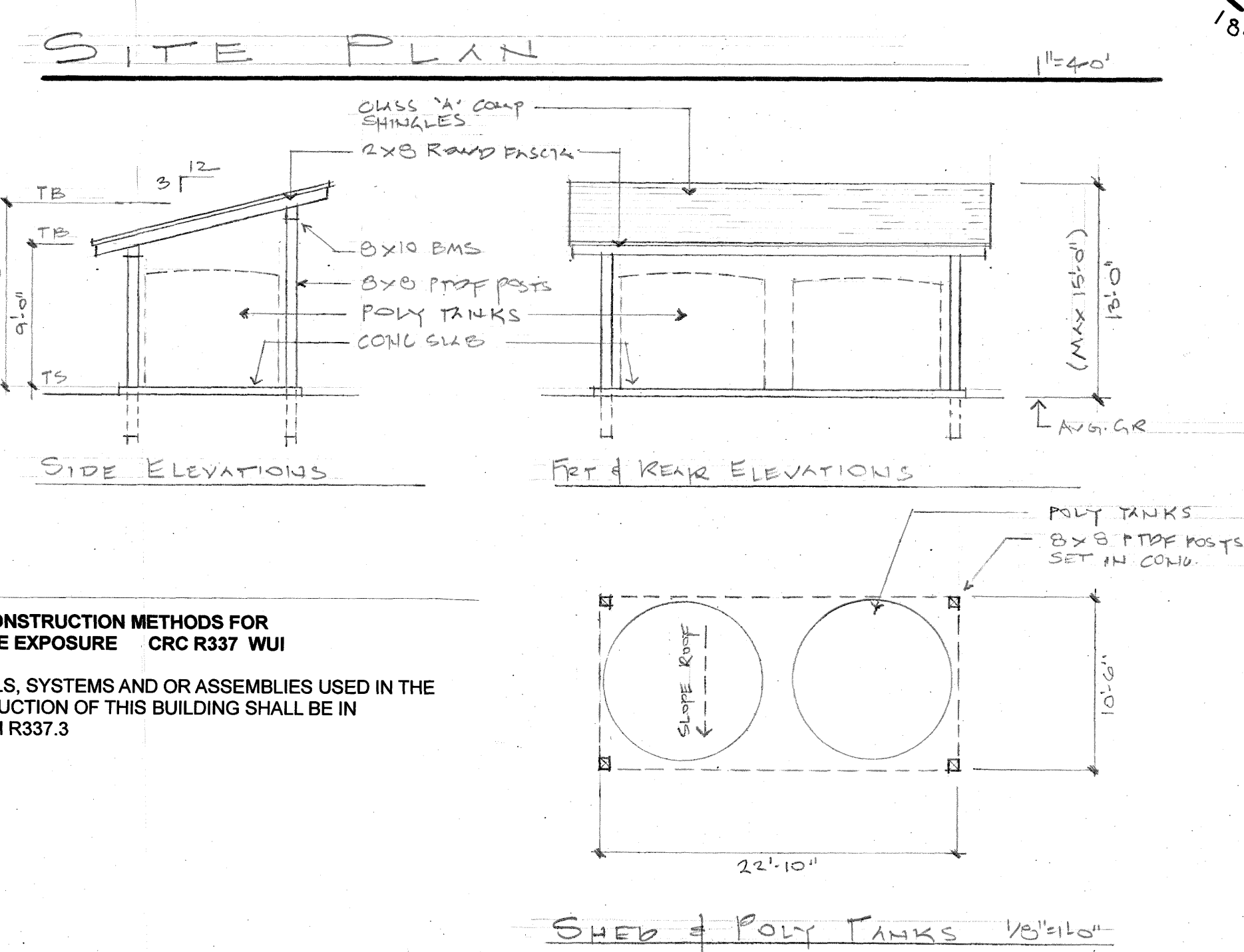
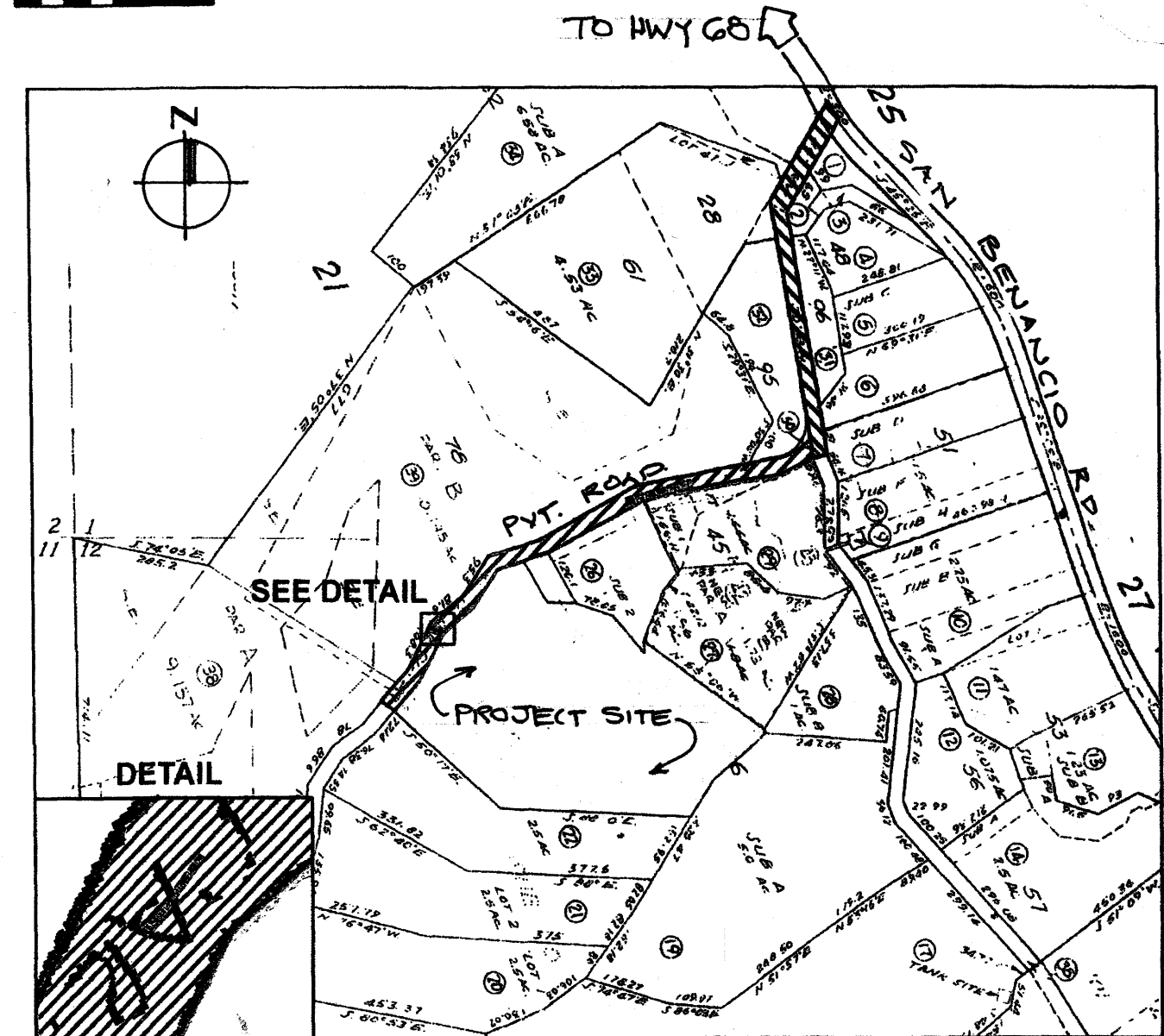
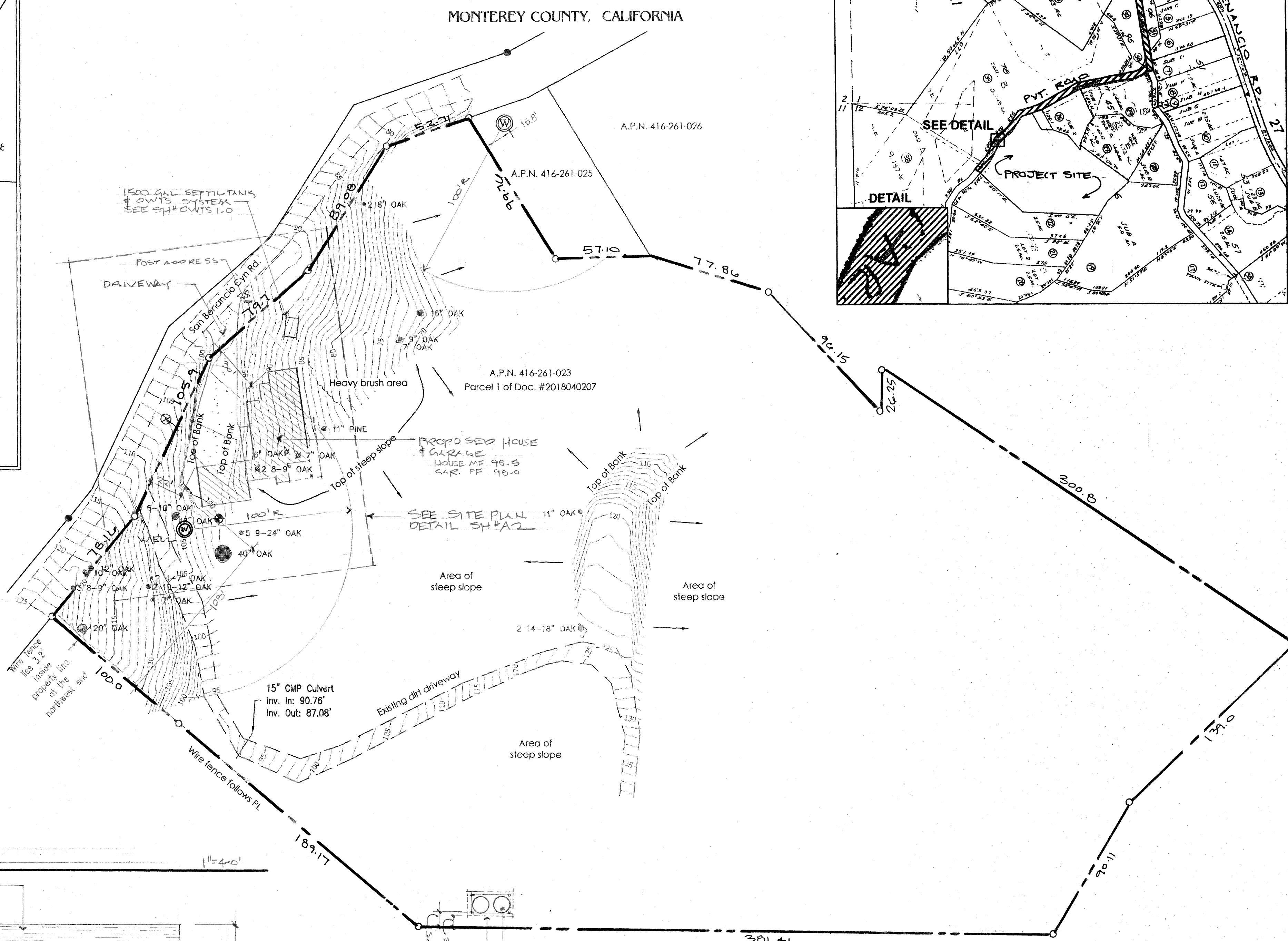

**MATERIALS AND CONSTRUCTION METHODS FOR EXTERIOR WILDFIRE EXPOSURE CRC R337 WUI**

BUILDING MATERIALS, SYSTEMS AND OR ASSEMBLIES USED IN THE EXTERIOR CONSTRUCTION OF THIS BUILDING SHALL BE IN ACCORDANCE WITH R337.3

**BUILDING CLASSIFICATION**

OCCUPANCY GROUP: R-3/U  
 CONSTRUCTION TYPE: V-B SPRINKLERED  
 STORIES: 2 HEIGHT: 22'-0"  
 CODES: 2022 CALIFORNIA CODES  
 WUI: CRC R337 MATERIALS AND CONSTRUCTION METHODS FOR EXTERIOR WILDFIRE EXPOSURE  
 SCOPE OF WORK: New two story residence with 1991 s.f. main floor and 1371 s.f. unfinished lower floor (daylight basement), 720 s.f. attached garage, 123 s.f. covered front porch, 386 s.f. uncovered deck, 1670 s.f. driveway. Excavate 62 c.y., Fill 97 c.y. Development on slopes exceeding 25% = 374 s.f.  
 (2) 5000 gal water tanks w/ 240 s.f. shed roof exempt from permit from building permit.  
 TREE REMOVAL: Tree removal being processed under TRM25  
 GROUND DISTURBANCE: 4504 S.F.  
 SEWER SYSTEM: SEPTIC OWTS WATER SYSTEM: PRIVATE WELL  
 FLOOR AREA: PROPOSED HOUSE MAIN FLR 1991 S.F.  
 LWR FLR 1371 S.F.  
 ATTACHED GARAGE 720 S.F.  
 COVERED FRONT PORCH 123 S.F.  
 UNCOVERED DECK 386 S.F.

ZONING: LDR-5-D  
 OWNER: Courtland Evers, PO Box 1749, Monterey, CA 93942, PH 831 601-6678  
 email: courtlandevers@gmail.com  
 DESIGNER: Draftect - Darren Davis, 2150 Garden Rd., Monterey, CA 93942, PH: 831 646-5986 email: darren@draftect.com

**Draftect**  
 BUILDING DESIGN & CONSULTING  
 2150 GARDEN RD., SUITE B3 / MONTEREY, CA 93940  
 (831) 646-5986

**Darren A. Davis**  
 Designer

**EVERS RESIDENCE**  
 148 SAN BENANCIO ROAD  
 SALINAS, CALIFORNIA 93908  
 APN: 416-261-023-000 PH: 831 601-6675

Date	11-8-25
Scale	
Drawn	
Job	33-2025
Sheet	AI
Of	9 Sheets

**DRAINAGE NOTES (SEE SH. C1 FOR GRADING NOTES)**

- Roof drain downspouts shall be installed on all roof gutters, and shall discharge onto concrete splash blocks or pavement, and drain away from structure as noted below, or shall connect to a 4 inch dia solid NDS underground conduit per plan. The conduit shall slope at a 1% gradient minimum and discharge into a cobble energy dissipators shown on plan.
- Area Drains to be connected to closed 4" solid NDS conduit and discharged into a cobble energy dissipator shown on plan. Install distribution boxes as needed.
- Foundation sub drains and retaining wall drains shall be installed on the uphill side of foundations in accordance to plan and details. Drain conduit to be a 4" dia perf. NDS pipe or equal, connected to a 4" dia. solid NDS pipe sloping at a 1% gradient minimum and discharge into cobble dissipators shown on plan.
- All finish grades including patios, and driveways shall be contoured to slope away from proposed structures:
  - Site Grading (CRC 401.3):** Surface Drainage shall be diverted to a storm sewer conveyance or other approved point of collection that does not create a hazard. Lots shall be graded to drain surface water away from foundation walls. The grade shall fall a minimum of 6 inches within the first 10 feet. **Exception:** Where lot lines, walls, slopes, or other physical barriers prohibit 6 inches of fall within 10 feet, drains or swales shall be constructed to ensure drainage away from the structure. Impervious surface (pavers, etc.) within 10 feet of the building foundation shall slope a minimum of 2 percent away from the building.
- All drainage facilities should be checked and maintained periodically to remove obstructions and assure proper function.
- See sheet #C2-C3 for erosion control and BMP's.
- See sheet #C1 for additional grading and drainage notes and details.

**MATERIALS AND CONSTRUCTION METHODS FOR EXTERIOR WILDFIRE EXPOSURE CRC R337 WUI**

BUILDING MATERIALS, SYSTEMS AND OR ASSEMBLIES USED IN THE EXTERIOR CONSTRUCTION OF THIS BUILDING SHALL BE IN ACCORDANCE WITH R337.3

**CONSULTANTS**

**SOILS ENGINEER, SEPTIC ENGINEER:** GRICE ENGINEERING  
 SAM GRICE, RCE 66857  
 FILE #7278-20.08, DATE: OCT 29, 2020  
 561-A BRUNKEN AVENUE  
 SALINAS, CA 93901  
 831 375-1198

FLOOR AREA:	PROPOSED HOUSE	MAIN FLR	1991 S.F.
		LWR FLR	1371 S.F.
		<b>TOTAL</b>	<b>3362 S.F.</b>
NEW GARAGE			720 S.F.

SITE COVERAGE:	PROPOSED HOUSE	1991 S.F.
	NEW GARAGE	720 S.F.
	COVERED FRONT PORCH	123 S.F.
	UNCOVERED DECK	386 S.F.
	<b>TOTAL COVERAGE</b>	<b>3220 S.F.</b>
LOT AREA	5 ACRES	= > 2%

**DEVELOPMENT ON SLOPES EXCEEDING 25%**

DEVELOPMENT ON SLOPES EXCEEDING 25%	496 S.F.
FOOTPRINT OF DEVELOPED AREA	
HOUSE & GARAGE	2711 S.F.
PORCH & DRIVEWAY	1793 S.F.
<b>TOTAL</b>	<b>4504 S.F.</b>
RATIO 496 / 4505 = 11%	

**NOTES:**

- ✕ DENOTES TREES REMOVED: 6", 7", 9" COASTAL LIVE OAKS - SEPARATE PERMIT
- ⊕ DENOTES DARK SKY EXTERIOR LIGHTS ON MOTION SENSORS

**FIRE SAFETY FUEL MANAGEMENT PLAN**

**"GREEN ZONE":** Grassland within 30 feet of house and deck shall be mowed at least once annually in late spring, or more as needed to control fuel hazard.

- All annual grassland should be mowed in late spring to a minimum height of 4 inches during the summer.
- To promote native perennial grasses and wildflower stands which are less flammable, it is best to avoid mowing more frequently than 60 days. Ideal mowing time is shortly after they have set seed.

Flammable shrubs within 30 feet of house and deck shall be removed.

**"MANAGEMENT ZONE":** Grassland 30 feet to 100 feet from house and deck shall be mowed as follows:

- All grass growing under trees, out to 6 feet beyond the driplines of the trees, should be mowed in early summer to a height of four inches.
- Within 30-100 feet of structures away from trees need not be mowed unless determined by owner or fire marshal.

**"TREE PRUNING"** Coastal Live Oak Trees within 100 feet of house and deck shall be pruned or maintained to reduce fire hazards as follows:

- All branches, living or dead, less than 3 inches diameter in width and less than either 8 feet from the ground or three times the height of any understory shrubs whichever is greater, shall be removed.
- Dead limbs less than 8 feet in height shall be removed.
- Healthy tree branches less than 3 inches in diameter or 8 inches diameter if split or diseased, should be removed to 8 feet above understory plants.
- Tree Service Co. shall determine additional pruning or trimming during maintenance.

**Note:** Fuel Management requirements are limited to project site within the property lines. No fuel management work is required outside project property lines.

**"EMERGENCY VEHICLE ACCESS"** Existing private roadway from San Benancio Rd., and proposed chip & seal driveway designed accommodate fire apparatus in accordance with Monterey County Fire Marshal.

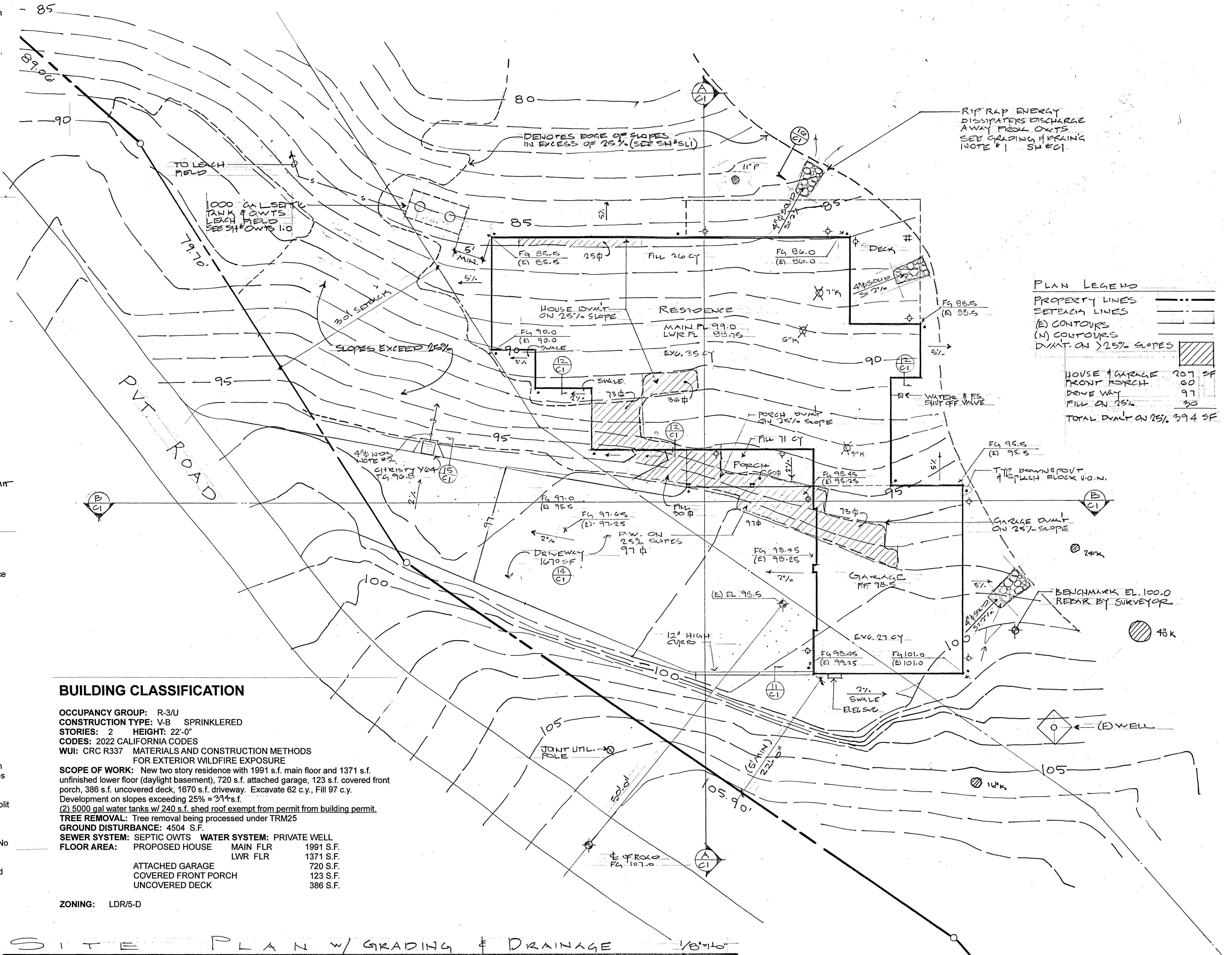

**BUILDING CLASSIFICATION**

**OCCUPANCY GROUP:** R-3/U  
**CONSTRUCTION TYPE:** V-B SPRINKLERED  
**STORIES:** 2 **HEIGHT:** 22'-0"  
**CODES:** 2022 CALIFORNIA CODES  
**WUI:** CRC R337 MATERIALS AND CONSTRUCTION METHODS FOR EXTERIOR WILDFIRE EXPOSURE  
**SCOPE OF WORK:** New two story residence with 1991 s.f. main floor and 1371 s.f. unfinished lower floor (daylight basement), 720 s.f. attached garage, 123 s.f. covered front porch, 386 s.f. uncovered deck, 1670 s.f. driveway. Excavate 62 c.y., Fill 97 c.y. Development on slopes exceeding 25% = 314 s.f.  
**(2) 5000 gal water tanks w/ 240 s.f. shed roof exempt from permit from building permit.**  
**TREE REMOVAL:** Tree removal being processed under TRM25  
**GROUND DISTURBANCE:** 4504 S.F.  
**SEWER SYSTEM:** SEPTIC OWTS **WATER SYSTEM:** PRIVATE WELL  
**FLOOR AREA:** PROPOSED HOUSE MAIN FLR 1991 S.F.  
 LWR FLR 1371 S.F.  
 ATTACHED GARAGE 720 S.F.  
 COVERED FRONT PORCH 123 S.F.  
 UNCOVERED DECK 386 S.F.

**ZONING:** LDR/S-D

**SITE PLAN W/ GRADING & DRAINAGE**

**PLAN LEGEND**

- PROPERTY LINES
  - SETBACK LINES
  - (E) CONTOURS
  - (N) CONTOURS
  - DWMT ON >25% SLOPES
- HOUSE & GARAGE 207 SF  
 FRONT PORCH 60  
 DRIVEWAY 97  
 DECK 386  
**TOTAL DWMT ON 25% 394 SF**

REVISIONS	BY
10-10-25	D
10-29-25	D
11-8-25	D
12-3-25	D
12-22-25	D
1-7-26	D
2-22-26	D

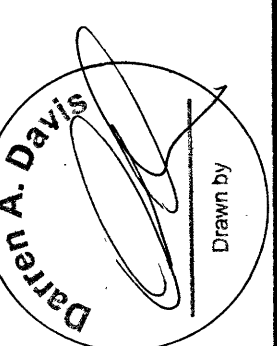
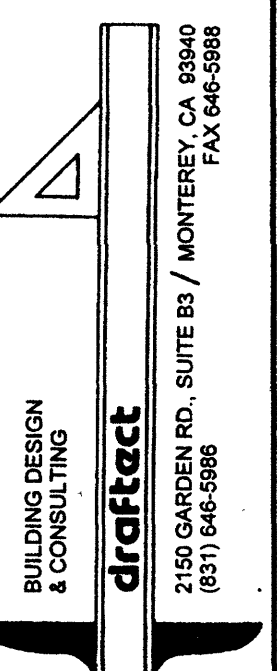

**EVERS RESIDENCE**  
 148 SAN BENANCIO ROAD  
 SALINAS, CALIFORNIA 93908  
 APN: 416-261-023-000 PH: 831 601-6675

Date	10-6-25
Scale	
Drawn	
Job	33-2025
Sheet	A2
Of	Sheets

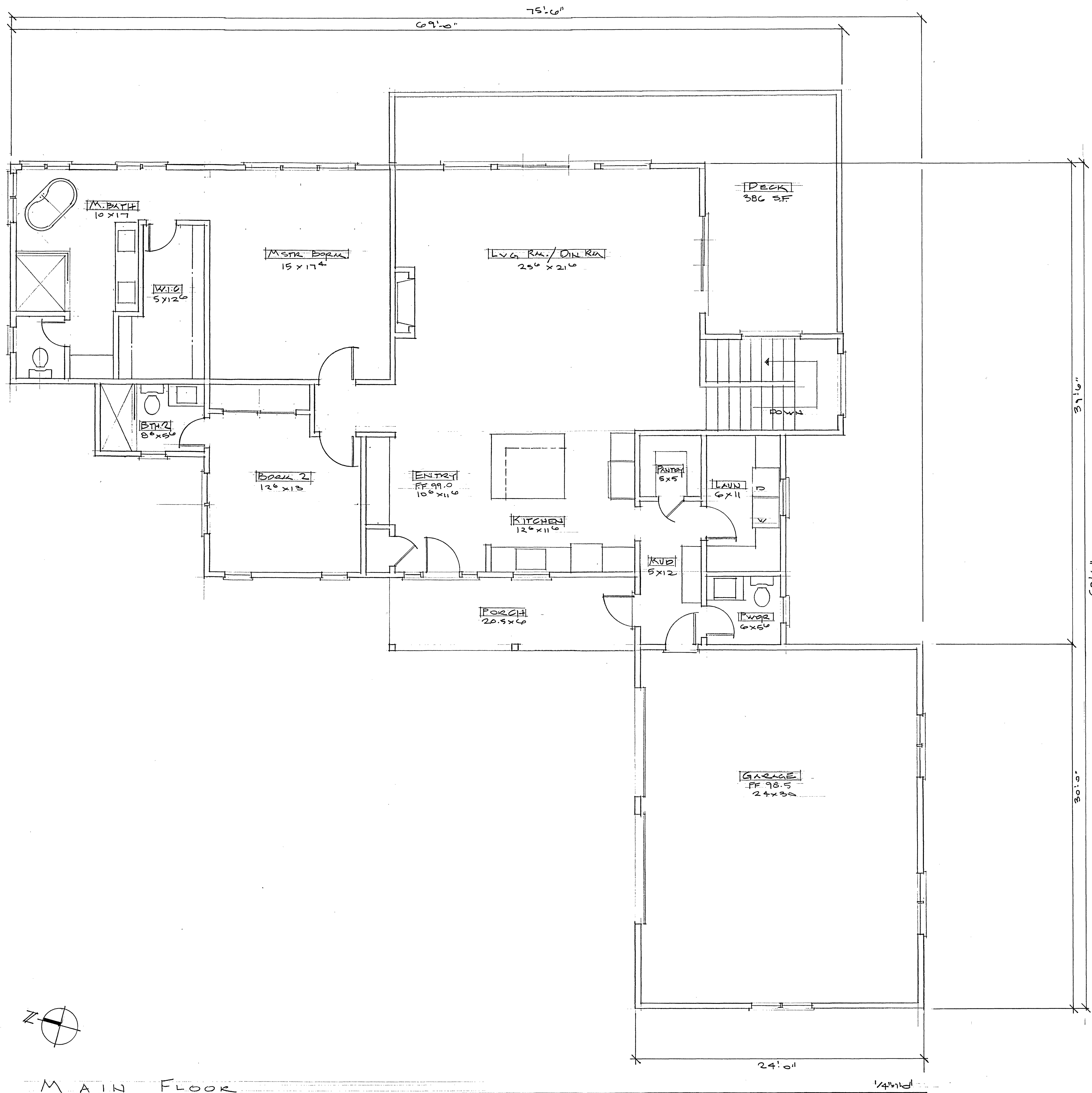

MAIN FLOOR

REVISIONS	BY
10-29-25	0
11-8-25	0

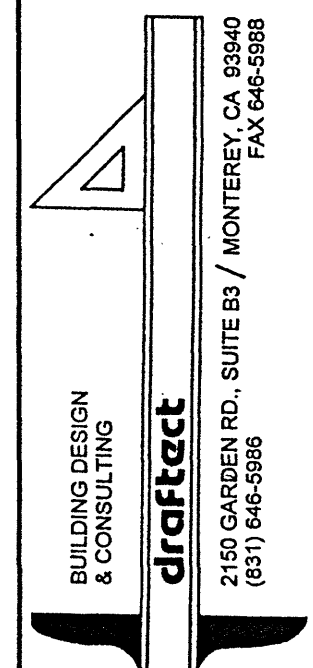

EVERS RESIDENCE  
 148 SAN BENANCIO ROAD  
 SALINAS, CALIFORNIA 93908  
 APN: 416-261-023-000 PH: 831 601-6675

Date	10-10-25
Scale	
Drawn	
Job	23-2025
Sheet	A3
Of	Sheets

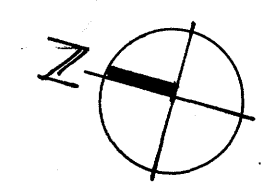
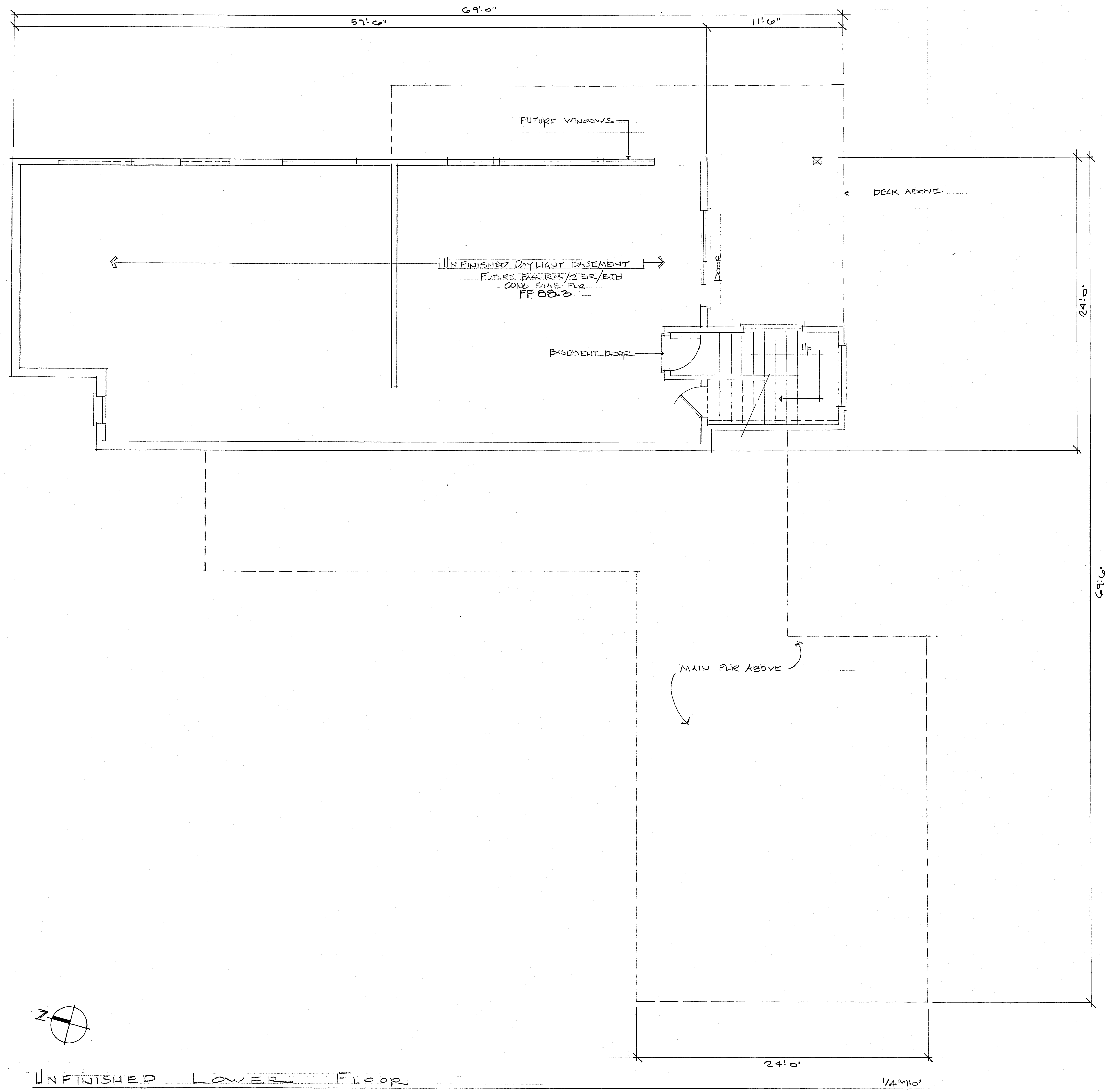

UNFINISHED LOWER FLOOR

24'-0"

1/4"=1'-0"

REVISIONS	BY

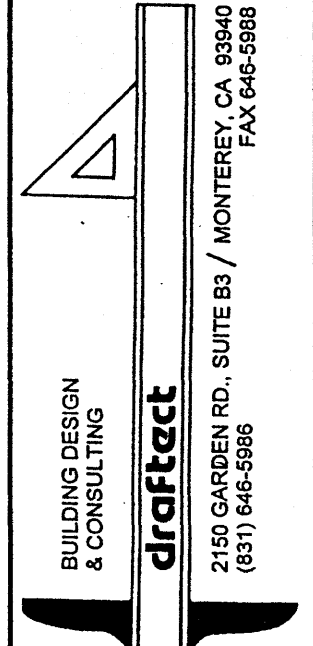

**EVERS RESIDENCE**  
 148 SAN BENANCIO ROAD  
 SALINAS, CALIFORNIA 93908  
 APN: 416-261-023-000 PH: 831 601-6675

Date 11-8-25

Scale

Drawn

Job 33-2025

Sheet

Of 4 Sheets

REVISIONS	BY
11-8-25	0

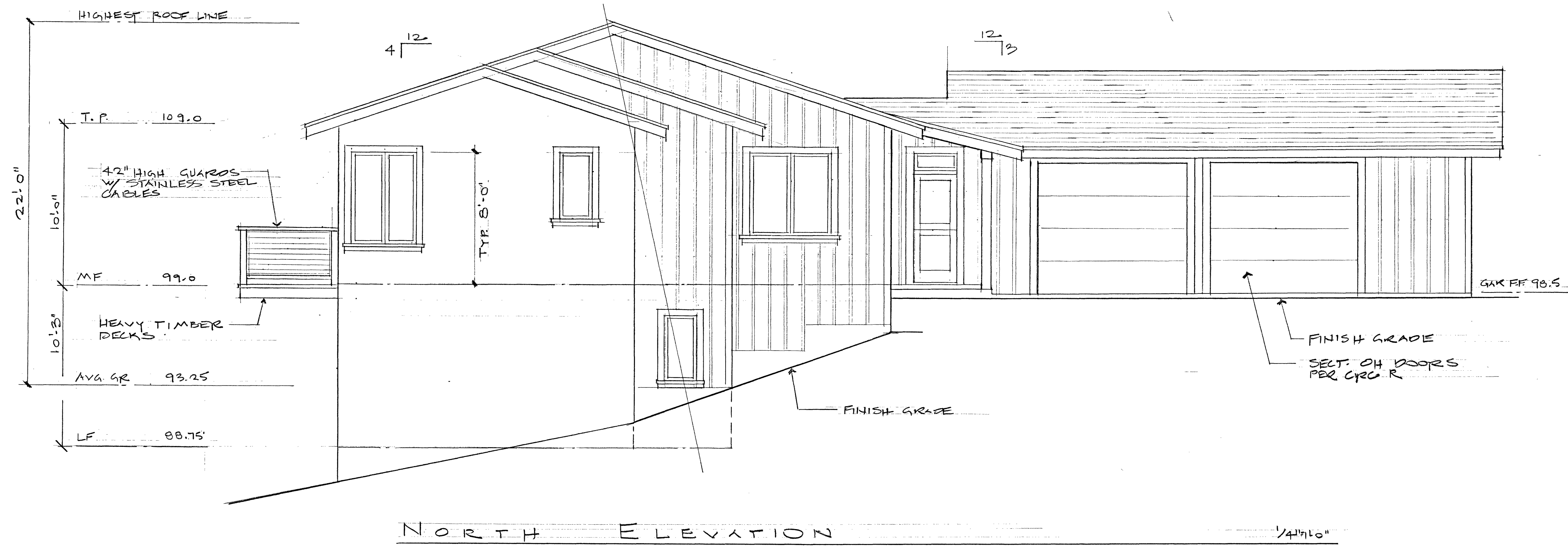

NORTH ELEVATION 1/4"=1'-0"

**MATERIALS AND CONSTRUCTION METHODS FOR EXTERIOR WILDFIRE EXPOSURE CRC R337 WUI**

BUILDING MATERIALS, SYSTEMS AND OR ASSEMBLIES USED IN THE EXTERIOR CONSTRUCTION OF THIS BUILDING SHALL BE IN ACCORDANCE WITH R337.3

SEE SHEET FOR SUMMARY AND SCHEMATIC OF EXTERIOR MATERIAL REQUIREMENTS



WEST ELEVATION 1/4"=1'-0"

BUILDING DESIGN & CONSULTING  
**draft**  
 2150 GARDEN RD., SUITE B3 / MONTEREY, CA 93940  
 (831) 646-9988

**EVERS RESIDENCE**  
 148 SAN BENANCIO ROAD  
 SALINAS, CALIFORNIA 93908  
 APN: 416-261-023-000 PH: 831 601-6675

Date 10-29-25  
 Scale  
 Drawn  
 Job 33-2025  
 Sheet  
**A5**  
 Of Sheets

REVISIONS	BY
11-8-25	0

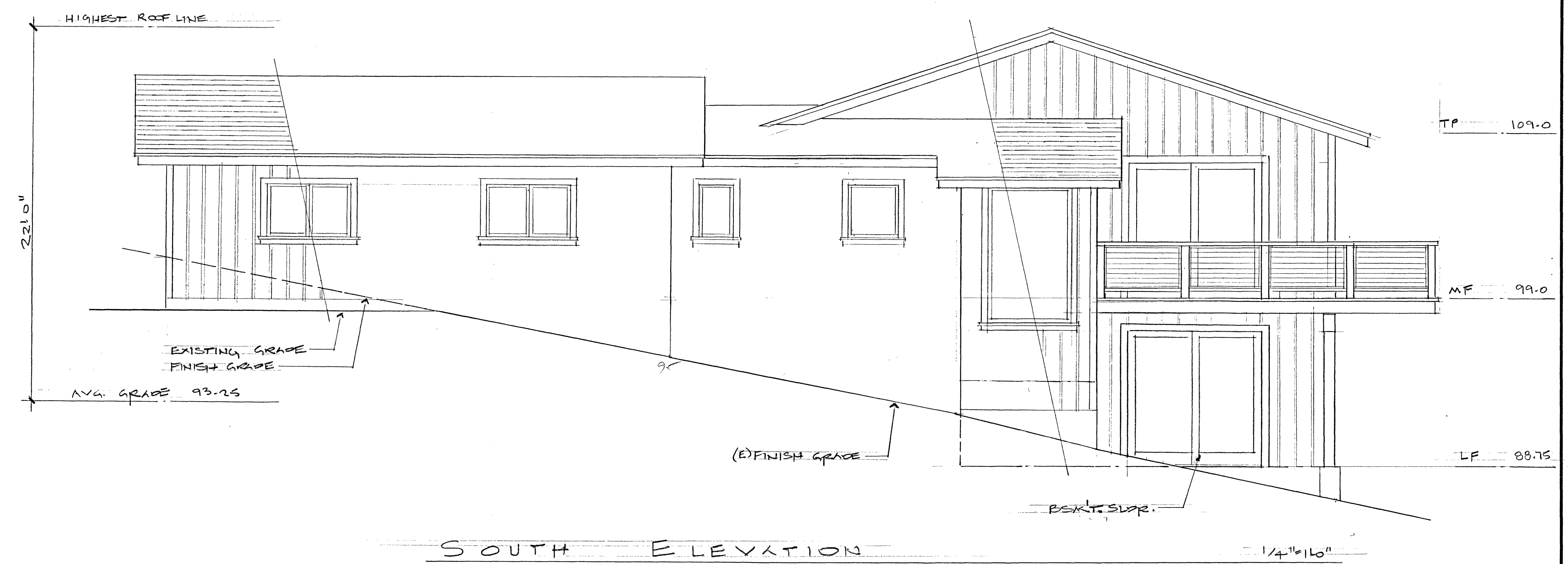

SOUTH ELEVATION

1/4"=1'-0"

MATERIALS AND CONSTRUCTION METHODS FOR EXTERIOR WILDFIRE EXPOSURE CRC R337 WUI  
 BUILDING MATERIALS, SYSTEMS AND OR ASSEMBLIES USED IN THE EXTERIOR CONSTRUCTION OF THIS BUILDING SHALL BE IN ACCORDANCE WITH R337.3  
 SEE SHEET FOR SUMMARY AND SCHEMATIC OF EXTERIOR MATERIAL REQUIREMENTS

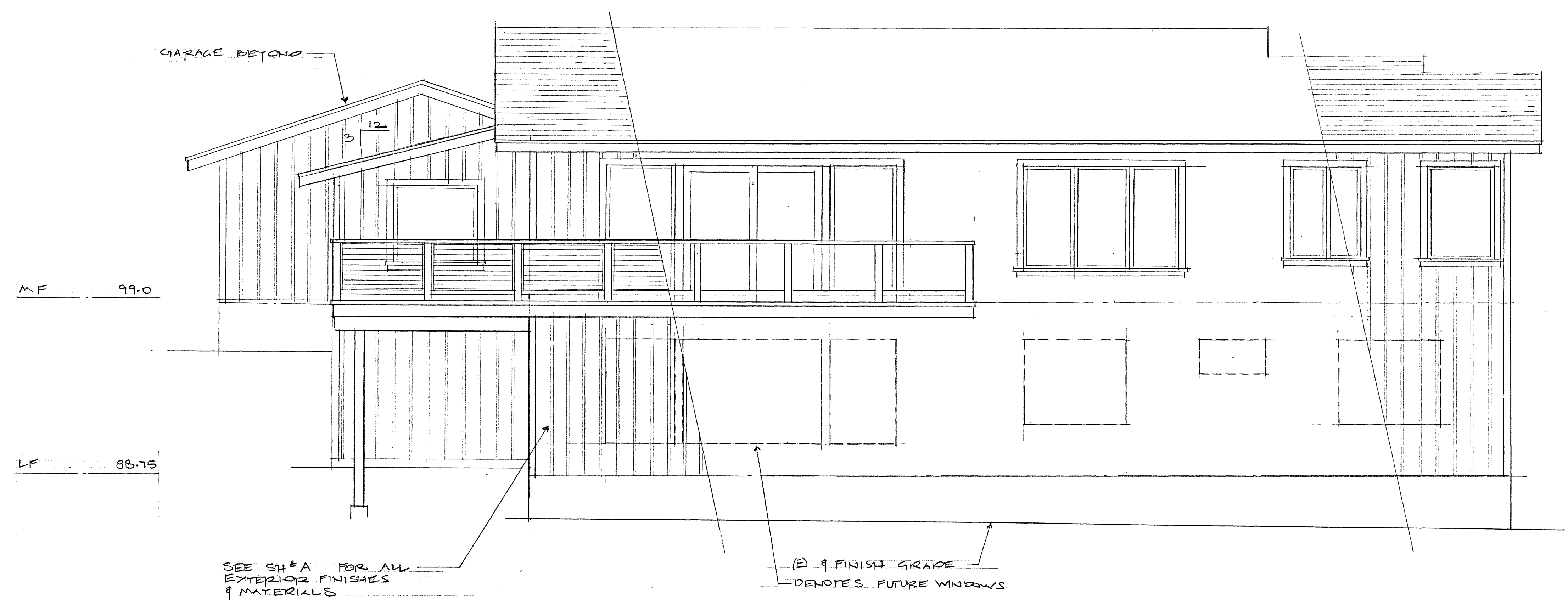

EAST ELEVATION

1/4"=1'-0"

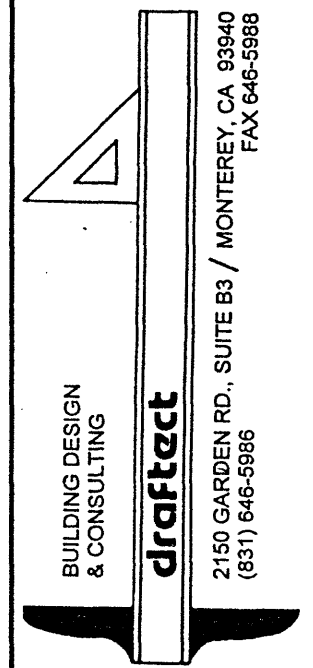

EVERS RESIDENCE  
 148 SAN BENANCIO ROAD  
 SALINAS, CALIFORNIA 93908  
 APN: 416-261-023-000 PH: 831 601-6675

Date 10-29-25

Scale

Drawn

Job 33-2025

Sheet

Of 6 Sheets

REVISIONS	BY
11-8-25	0

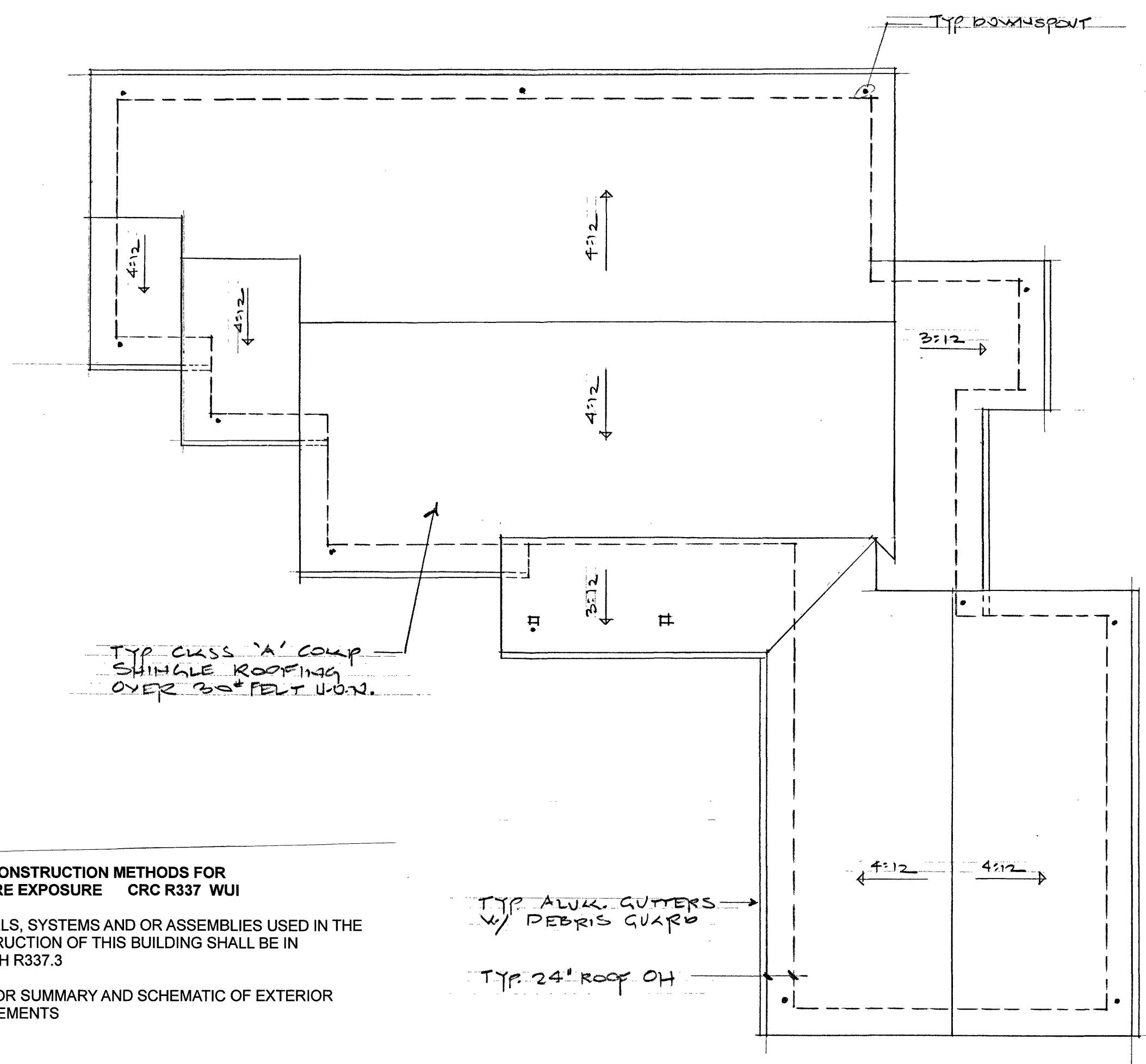
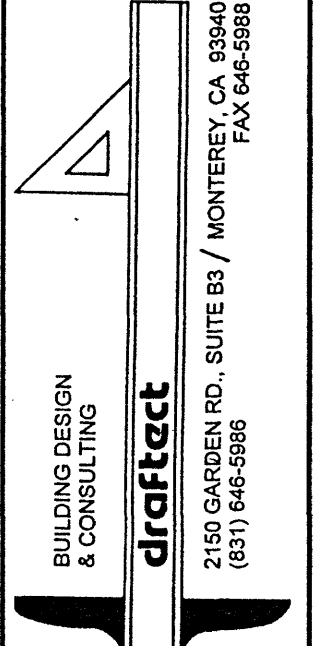

MATERIALS AND CONSTRUCTION METHODS FOR  
EXTERIOR WILDFIRE EXPOSURE CRC R337 WUI

BUILDING MATERIALS, SYSTEMS AND OR ASSEMBLIES USED IN THE  
EXTERIOR CONSTRUCTION OF THIS BUILDING SHALL BE IN  
ACCORDANCE WITH R337.3

SEE SHEET FOR SUMMARY AND SCHEMATIC OF EXTERIOR  
MATERIAL REQUIREMENTS

ROOF PLAN 1/8/2025

EVERS RESIDENCE  
148 SAN BENANCIO ROAD  
SALINAS, CALIFORNIA 93908  
APN: 416-261-023-000 PH: 831 601-6675

Date	10-29-25
Scale	
Drawn	
Job	23-2025
Sheet	A7
Of	Sheets

REVISIONS	BY
10-10-25	B
10-29-25	B
11-8-25	B
2-22-26	B

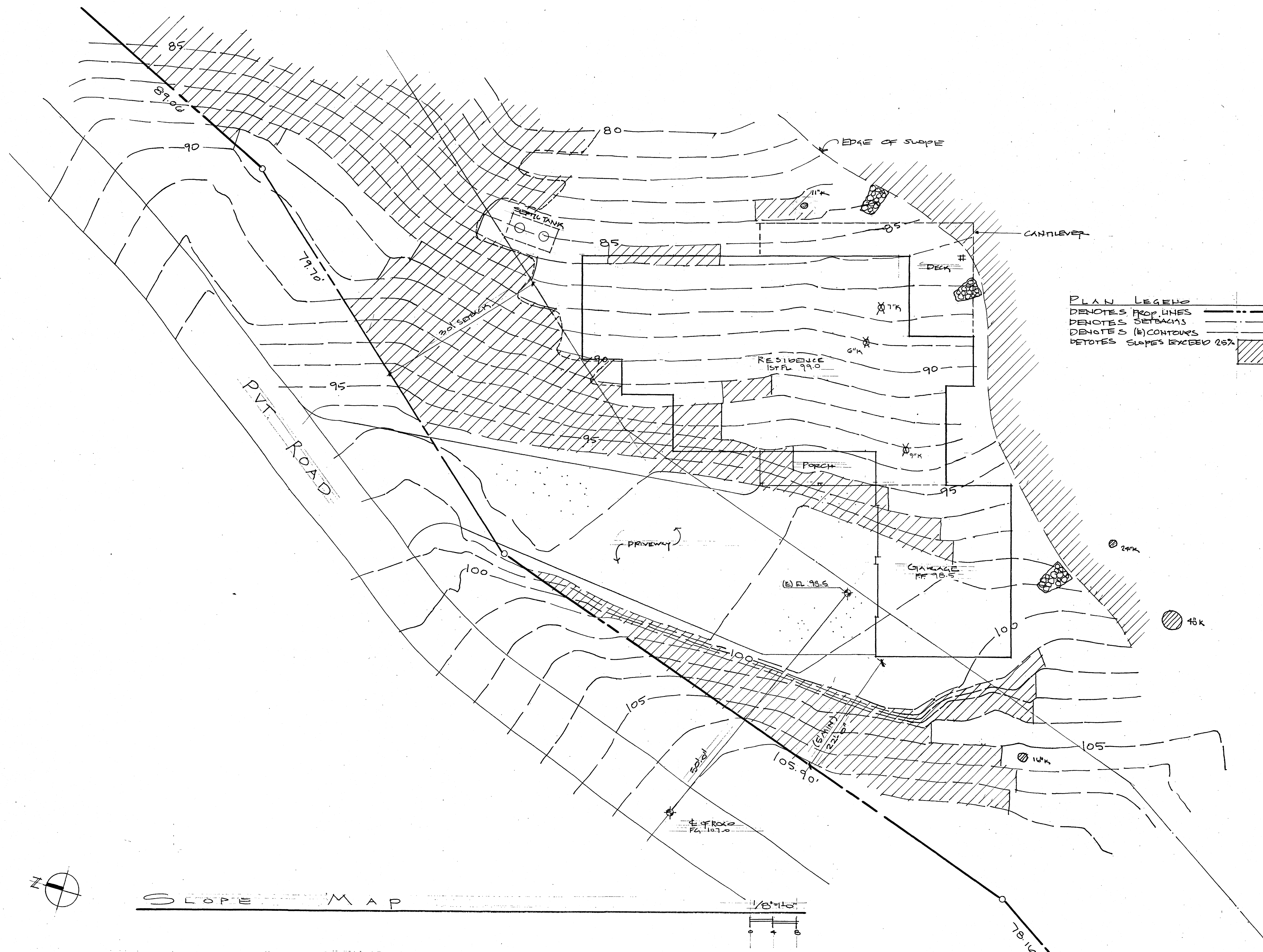
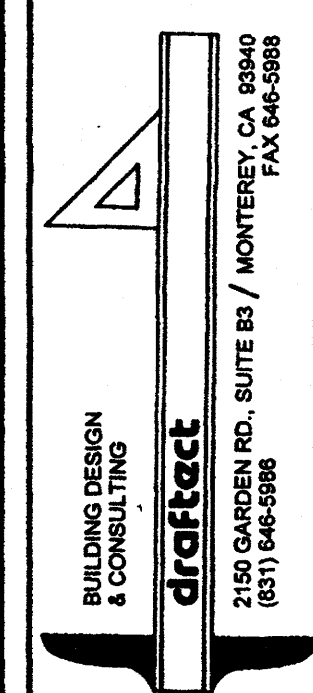

SLOPE MAP

EVERS RESIDENCE  
 148 SAN BENANCIO ROAD  
 SALINAS, CALIFORNIA 93908  
 APN: 416-261-023-000 PH: 831 601-6675

Date 10-6-25  
 Scale  
 Drawn  
 Job 33-2025  
 Sheet  
 Of 1 Sheets

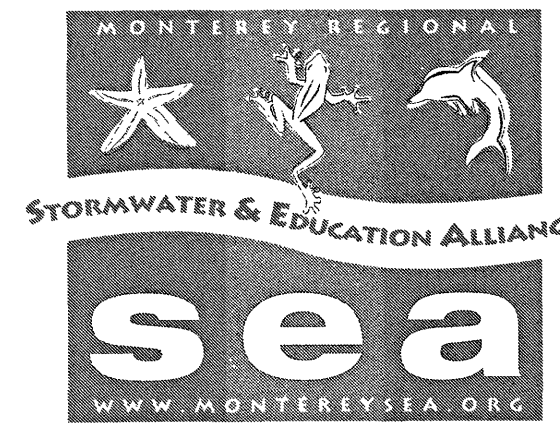

# CONSTRUCTION BEST MANAGEMENT PRACTICES (BMPs)

Construction Projects Are Required to Implement the Stormwater Best Management Practices (BMP) on this Page, as they Apply to Your Project, All Year Long

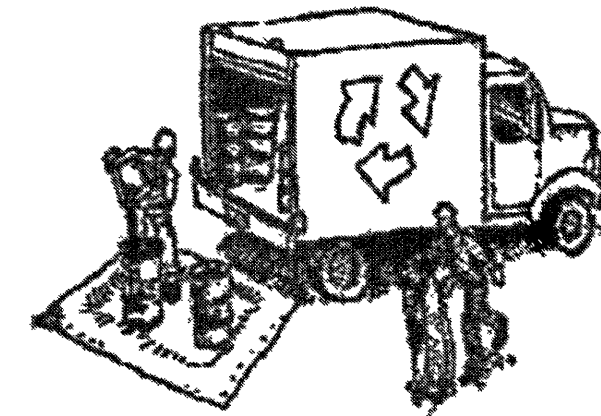

## MATERIALS & WASTE MANAGEMENT

### Non-Hazardous Materials

- Berm and cover stockpiles of sand, dirt or other construction material with tarps when rain is forecast or if not actively being used within 14 days.
- Use (but don't overuse) reclaimed water for dust control.

### Hazardous Materials

- Label all hazardous materials and hazardous wastes (such as pesticides, paints, thinners, solvents, fuel, oil, and antifreeze) in accordance with city, county, state and federal regulations.
- Store hazardous materials and wastes in water tight containers, store in appropriate secondary containment, and cover them at the end of every work day or during wet weather or when rain is forecast.
- Follow manufacturer's application instructions for hazardous materials and be careful not to use more than necessary. Do not apply chemicals outdoors when rain is forecast within 24 hours.
- Arrange for appropriate disposal of all hazardous wastes.

### Waste Management

- Cover waste disposal containers securely with tarps at the end of every work day and during wet weather.
- Check waste disposal containers frequently for leaks and to make sure they are not overfilled. Never hose down a dumpster on the construction site.
- Clean or replace portable toilets, and inspect them frequently for leaks and spills.
- Dispose of all wastes and debris properly. Recycle materials and wastes that can be recycled (such as asphalt, concrete, aggregate base materials, wood, gyp board, pipe, etc.)
- Dispose of liquid residues from paints, thinners, solvents, glues, and cleaning fluids as hazardous waste.

### Construction Entrances and Perimeter

- Establish and maintain effective perimeter controls and stabilize all construction entrances and exits to sufficiently control erosion and sediment discharges from site and tracking off site.
- Sweep or vacuum any street tracking immediately and secure sediment source to prevent further tracking. Never hose down streets to clean up tracking.

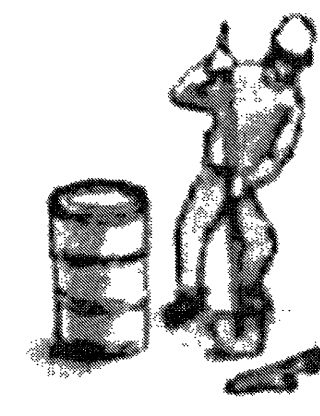

## EQUIPMENT MANAGEMENT & SPILL CONTROL

### Maintenance and Parking

- Designate an area, fitted with appropriate BMPs, for vehicle and equipment parking and storage.
- Perform major maintenance, repair jobs, and vehicle and equipment washing off site.
- If refueling or vehicle maintenance must be done onsite, work in a bermed area away from storm drains and over a drip pan big enough to collect fluids. Recycle or dispose of fluids as hazardous waste.
- If vehicle or equipment cleaning must be done onsite, clean with water only in a bermed area that will not allow rinse water to run into gutters, streets, storm drains, or surface waters.
- Do not clean vehicle or equipment onsite using soaps, solvents, degreasers, steam cleaning equipment, etc.

### Spill Prevention and Control

- Keep spill cleanup materials (rags, absorbents, etc.) available at the construction site at all times.
- Inspect vehicles and equipment frequently for and repair leaks promptly. Use drip pans to catch leaks until repairs are made.
- Clean up spills or leaks immediately and dispose of cleanup materials properly.
- Do not hose down surfaces where fluids have spilled. Use dry cleanup methods (absorbent materials, cat litter, and/or rags).
- Sweep up spilled dry materials immediately. Do not try to wash them away with water, or bury them.
- Clean up spills on dirt areas by digging up and properly disposing of contaminated soil.
- Report significant spills immediately. You are required by law to report all significant releases of hazardous materials, including oil. To report a spill: 1) Dial 911 or your local emergency response number, 2) Call the Governor's Office of Emergency Services Warning Center, (800) 852-7550 (24 hours).



## EARTHWORK & CONTAMINATED SOILS

### Erosion Control

- Schedule grading and excavation work for dry weather only.
- Stabilize all denuded areas, install and maintain temporary erosion controls (such as erosion control fabric or bonded fiber matrix) until vegetation is established.
- Seed or plant vegetation for erosion control on slopes or where construction is not immediately planned.

### Sediment Control

- Protect storm drain inlets, gutters, ditches, and drainage courses with appropriate BMPs, such as gravel bags, fiber rolls, berms, etc.
- Prevent sediment from migrating offsite by installing and maintaining sediment controls, such as fiber rolls, silt fences, or sediment basins.
- Keep excavated soil on the site where it will not collect into the street.
- Transfer excavated materials to dump trucks on the site, not in the street.
- Contaminated Soils
- If any of the following conditions are observed, test for contamination and contact the Regional Water Quality Control Board:
  - Unusual soil conditions, discoloration, or odor.
  - Abandoned underground tanks
  - Abandoned wells
  - Buried barrels, debris, or trash.

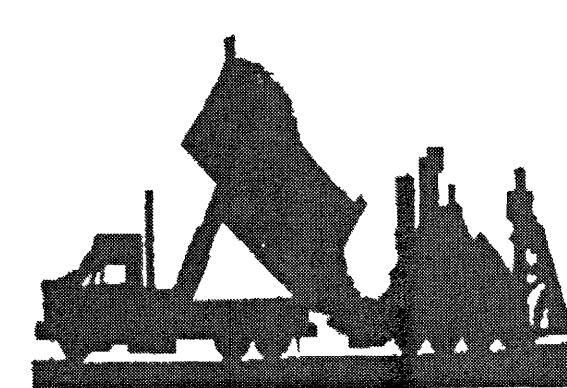

## PAVING/ASPHALT WORK

- Avoid paving and seal coating in wet weather, or when rain is forecast before fresh pavement will have time to cure.
- Cover storm drain inlets and manholes when applying seal coat, tack coat, slurry seal, fog seal, etc.
- Collect and recycle or appropriately dispose of excess abrasive gravel or sand. Do NOT sweep or wash it into gutters.
- Do not use water to wash down fresh asphalt concrete pavement.

### Sawcutting & Asphalt/Concrete Removal

- Completely cover or barricade storm drain inlets when saw cutting. Use filter fabric, catch basin inlet filters, or gravel bags to keep slurry out of the storm drain system.
- Shovel, absorb, or vacuum saw-cut slurry and dispose of all waste as soon as you are finished in one location or at the end of each work day (whichever is sooner!)
- If sawcut slurry enters a catch basin, clean it up immediately.

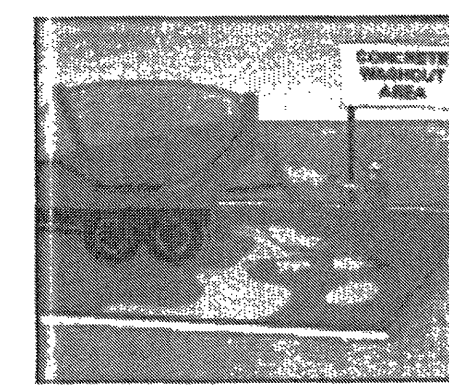

## CONCRETE, GROUT & MORTAR APPLICATION

- Store concrete, grout and mortar under cover, on pallets and away from drainage areas. These materials must never reach a storm drain.
- Wash out concrete equipment/trucks offsite or in a contained area, so there is no discharge into the underlying soil or onto surrounding areas. Let concrete harden and dispose of as garbage.
- Collect the wash water from washing exposed aggregate concrete and remove it for appropriate disposal offsite.



## LANDSCAPE MATERIALS

- Contain stockpiled landscaping materials by storing them under tarps when they are not actively being used.
- Stack erodible landscape material on pallets. Cover or store these materials when they are not actively being used or applied.
- Discontinue application of any erodible landscape material within 2 days before a forecast rain event or during wet weather.

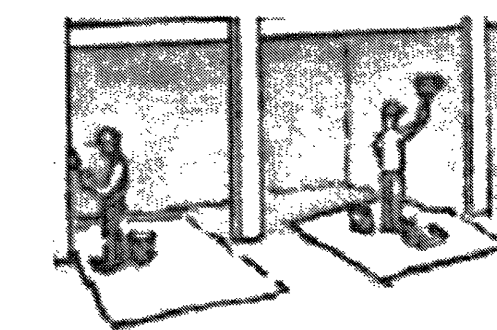

## PAINTING & PAINT REMOVAL

### Painting cleanup

- Never clean brushes or rinse paint containers into a street, gutter, storm drain, or surface waters.
- For water-based paints, paint out brushes to the extent possible. Rinse to the sanitary sewer once you have gained permission from the local wastewater treatment authority. Never pour paint down a drain.
- For oil-based paints, paint out brushes to the extent possible and clean with thinner or solvent in a proper container. Filter and reuse thinners and solvents. Dispose of residue and unusable thinner/solvents as hazardous waste.

### Paint Removal

- Chemical paint stripping residue and chips and dust from marine paints or paints containing lead or tributyltin must be disposed of as hazardous waste.
- Paint chips and dust from non-hazardous dry stripping and sand blasting may be swept up or collected in plastic drop cloths and disposed of as trash.

To Report a Spill: Call 911 or (831) 394-6811

If you see paint, cement, motor oil, antifreeze or other hazardous materials flowing into or being dumped into a storm drain, immediately call 911 to report it.

### Additional Contact Numbers (Non-Emergency):

- City of Carmel-by-the-Sea: (831) 620-2000
- City of Del Rey Oaks: (831) 394-8511
- City of Monterey: (831) 646-3921
- City of Pacific Grove: (831) 648-5722
- City of Sand City: (831) 394-3054
- City of Seaside: (831) 899-6825
- County of Monterey: (831) 755-4800

\* Adapted with permission from the San Mateo Countywide Water Pollution Prevention Program

**STORM DRAIN POLLUTERS MAY BE LIABLE FOR FINES OF UP TO \$10,000 PER DAY!**

REVISIONS	BY

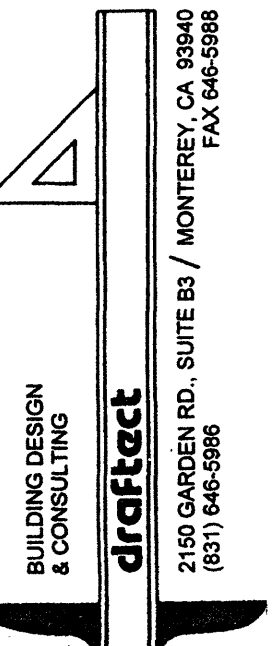

**EVERS RESIDENCE**  
**148 SAN BENANCIO ROAD**  
**SALINAS, CALIFORNIA 93908**  
**APN: 416-261-023-000 PH: 831 601-6675**

Date	11.20.25
Scale	
Drawn	
Job	33-2025
Sheet	
Of	2 Sheets

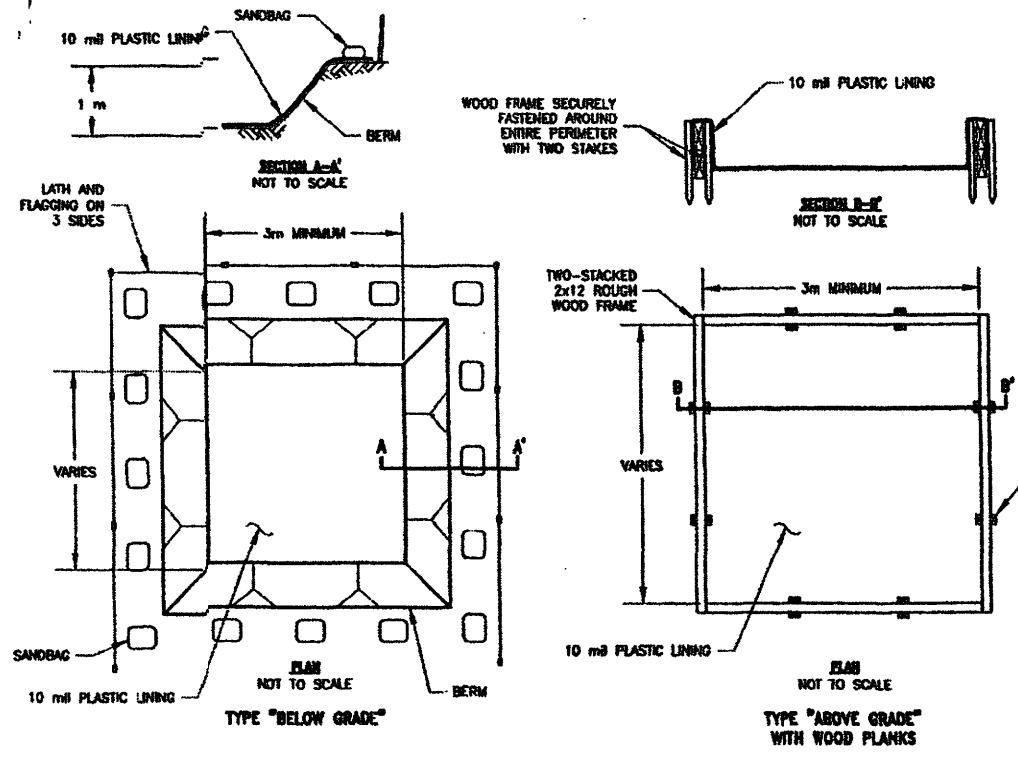

**CONCRETE WASTE MANAGEMENT WM-8**

5

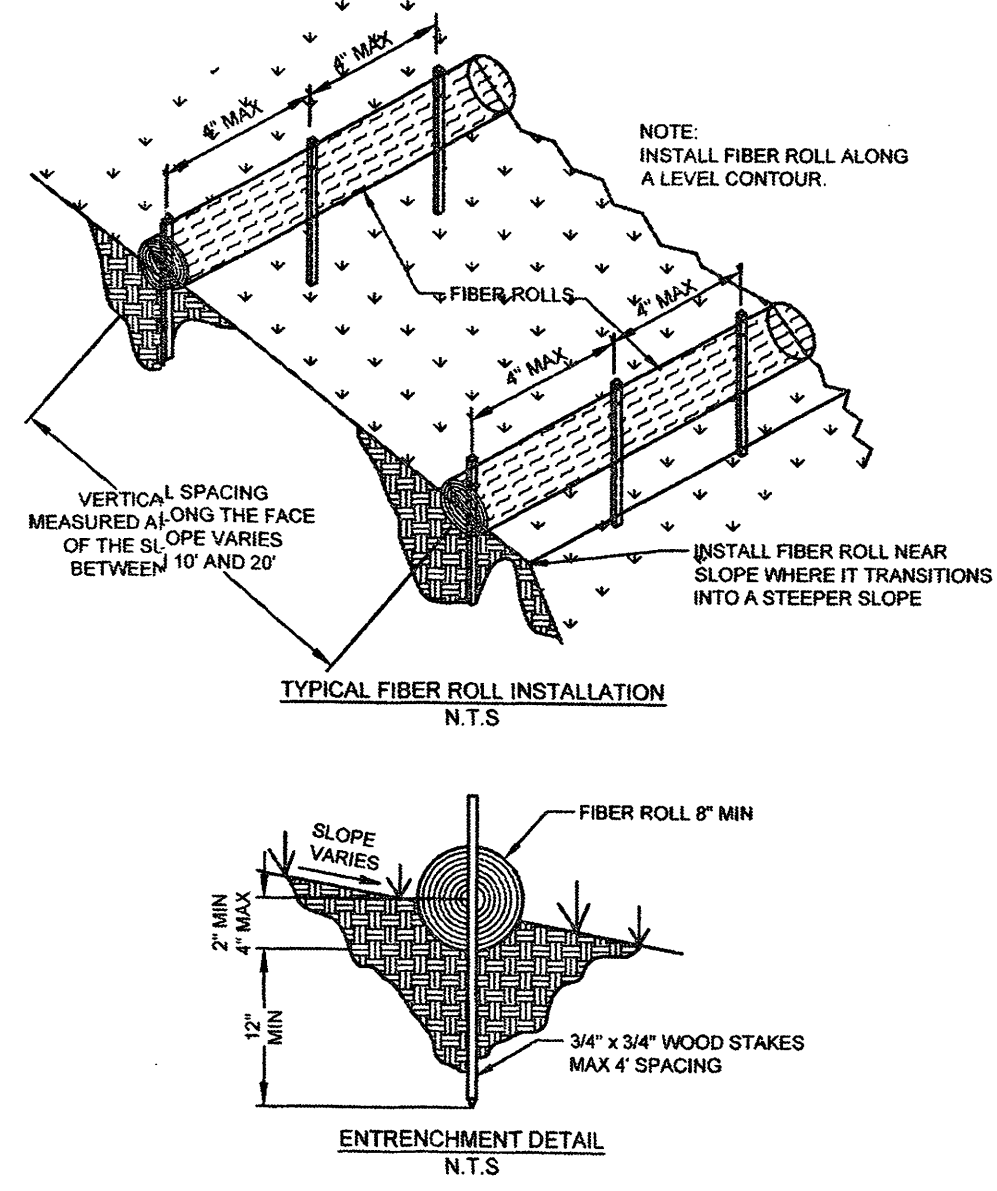

**FIBER ROLLS**

NTS

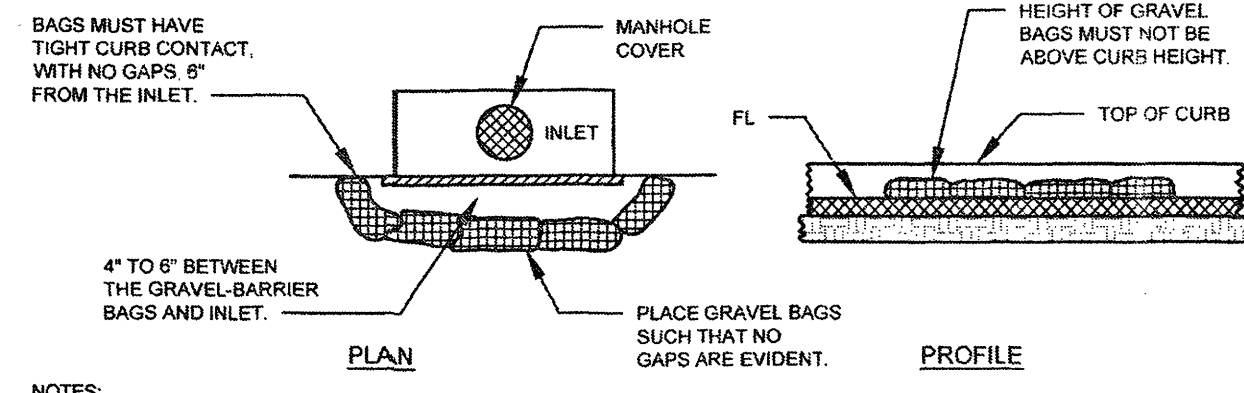

**DRAIN INLET BARRIER**

NTS

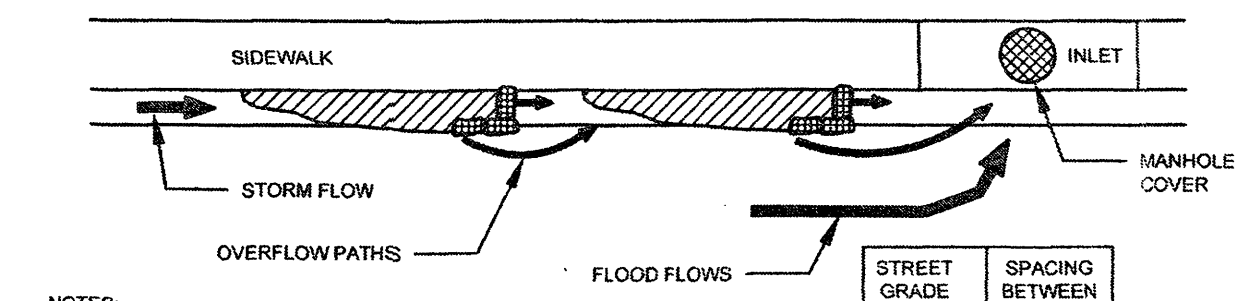

**CURB AND GUTTER CONTAINMENT**

NTS

STREET GRADE (ft)	SPACING BETWEEN BAGS (ft)
0.5	100
1.0	50
2.0	25
3.0	16
4.0	13
5.0	10

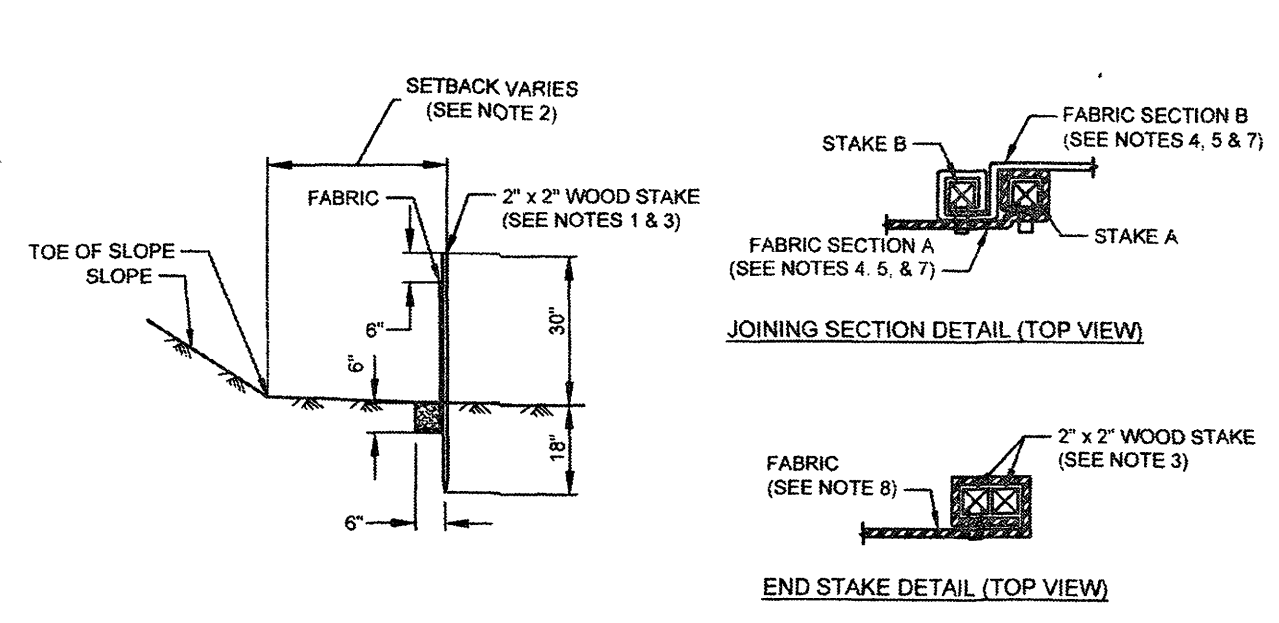

**SILT FENCE**

NTS

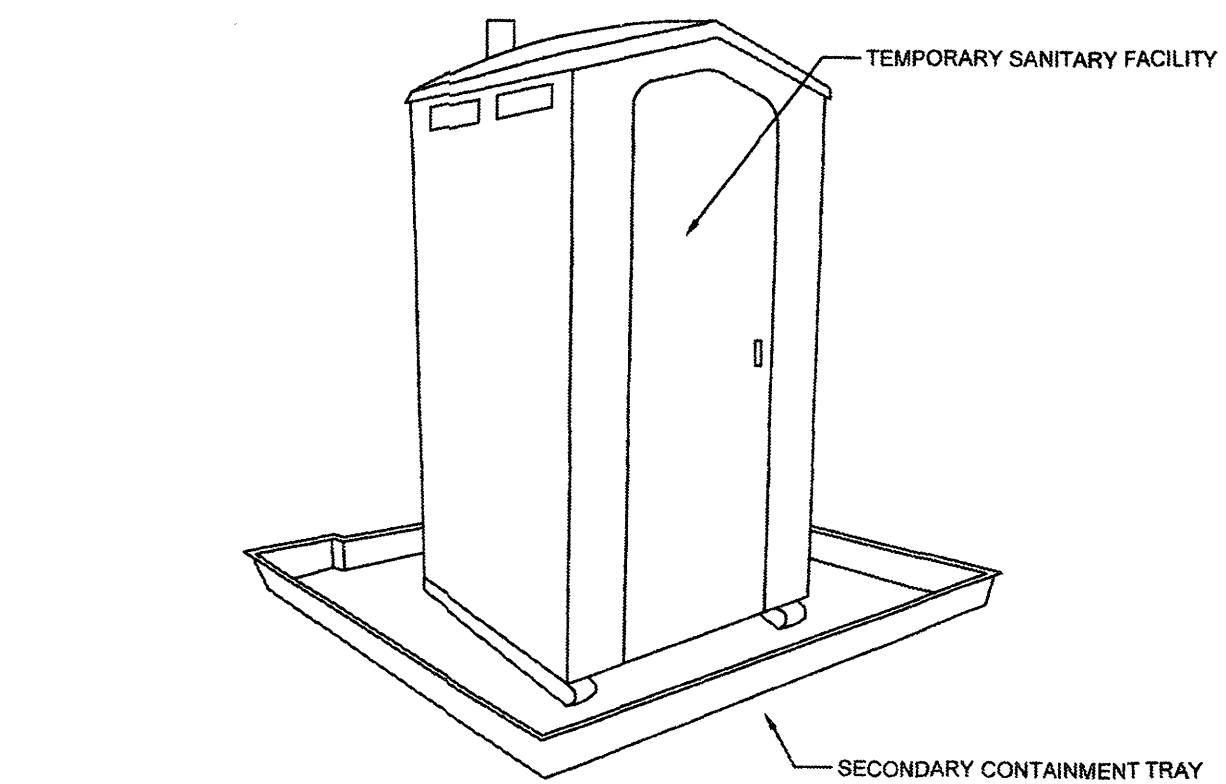

**STORAGE AND DISPOSAL PROCEDURES**

- TEMPORARY SANITARY FACILITIES SHOULD BE LOCATED AWAY FROM DRAINAGE FACILITIES, WATERCOURSES, AND FROM TRAFFIC CIRCULATION. IF SITE CONDITIONS ALLOW, PLACE PORTABLE FACILITIES A MINIMUM OF 50 FEET FROM DRAINAGE CONVEYANCES AND TRAFFIC AREAS.
- WHEN SUBJECTED TO HIGH WINDS OR RISK OF HIGH WINDS, TEMPORARY SANITARY FACILITIES SHOULD BE SECURED TO PREVENT OVERTURNING.
- TEMPORARY SANITARY FACILITIES MUST BE EQUIPPED WITH SECONDARY CONTAINMENT TRAYS TO PREVENT DISCHARGE OF POLLUTANTS TO THE STORMWATER DRAINAGE SYSTEM OF THE RECEIVING WATER.
- ARRANGE FOR REGULAR WASTE COLLECTION, DO NOT ALLOW SANITARY FACILITY TO BECOME OVERFULL.

**SANITARY WASTE MANAGEMENT**

NTS

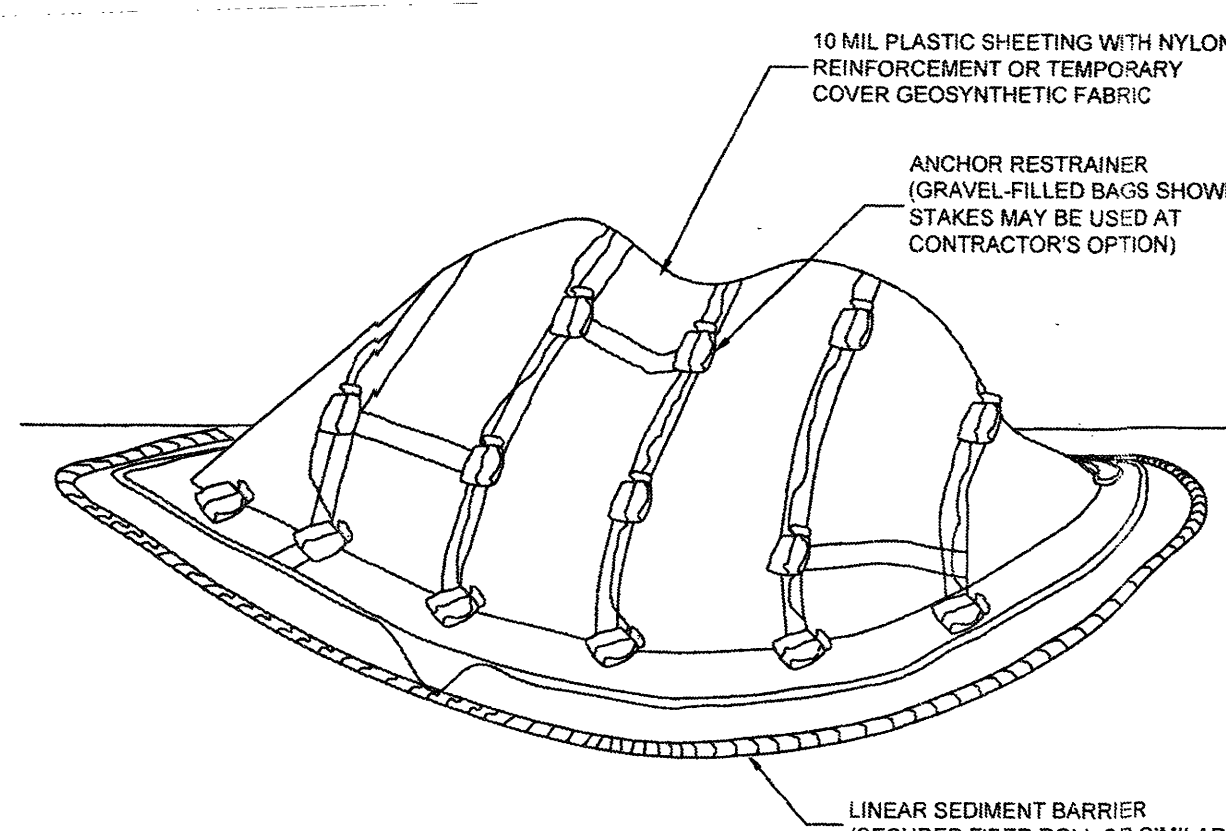

**TEMPORARY COVER ON STOCKPILE**

**TEMPORARY COVER ON STOCKPILE**

NTS

7

**HCD - ENVIRONMENTAL SERVICES NOTES**

- All or part of the construction of this project is expected to occur during the winter season (October 15<sup>th</sup> through April 15<sup>th</sup>) ? YES / NO
- All grading shall conform to the Monterey County Grading Ordinance #2535, Erosion Control Ordinance #2806, and California Building Code.
- It shall be the responsibility of the owner and the permittee to ensure that erosion does not occur from an activity during or after project construction. Additional measures, beyond those specified, may be required as deemed necessary to control accelerated erosion (MCC 16.12.100).
- Temporary erosion control to be installed between October 15 and April 15.
- Vegetation removal between October 15 and April 15 shall not precede subsequent grading or construction by more than 15 days. During this period, erosion and sediment control measures shall be in place at the end of each working day.
- During construction the applicant shall schedule an inspection with HCD-Environmental Services to inspect drainage device installation, review the maintenance and effectiveness of BMPs installed, and to verify that pollutants of concern are not discharged from the site. At the time of the inspection, the applicant shall provide certification that all necessary geotechnical inspections have been completed to that point.
- Dust from grading operations must be controlled. The owner or contractor may be required to keep adequate equipment on the grading site to prevent dust problems.
- The Director of Building Inspection (Building Official) shall stop operations during periods of inclement weather if he or she determines that erosion problems are not being controlled adequately.
- Prior to commencement of any land disturbance, the owner/applicant shall schedule an inspection with HCD-Environmental Services to ensure all necessary sediment controls are in place and the project is compliant with Monterey County grading and erosion control regulations.

**Prior to Building Final:**

- Prior to final inspection, the owner/applicant shall schedule and inspection with HCD-Environmental Services to conduct a Final Grading Inspection, collect Final Geotechnical Letter of Conformance, ensure that all disturbed areas have been stabilized and that all temporary erosion and sediment control measures that are no longer needed have been removed.

**Erosion Control Legend**

- (A) **Tracking Control:** Prevent tracking dirt offsite. Use gravel and corrugated steel plates or equal to provide a stabilized entrance and exit for vehicles. Clean plates regularly and replace gravel when no longer effective. Maintain dust control and implement street sweeping and vacuuming as needed
- (B) **Solid Waste Management:** 3 c.y. container with lid
- (C) **Sanitary/Septic Waste Management:** Portable Bathroom w/ containment underneath (WM-9)
- (D) **Concrete Washout (WM-8)**
- (E) **Stockpile Management -** Fiber rolls or gravel bags around with visqueen cover and gravel bags on top to secure visqueen (WM-3)
- (F) **Perimeter Control:** Fiber Rolls or Silt Fencing
- (G) **Earth moving Equipment w/ containment underneath**
- (H) **Material Delivery and Storage, cover when not in use (WM-1)**
- (J) **Crew Parking**

**Notes:** 1) Earth moving equipment, trailers, and pickup trucks may be parked on shoulder of private easement road as long as 12' clear right-of-way is provided for through traffic to neighboring houses. No parking on public roads. 2) See sheet C1 for BMP's

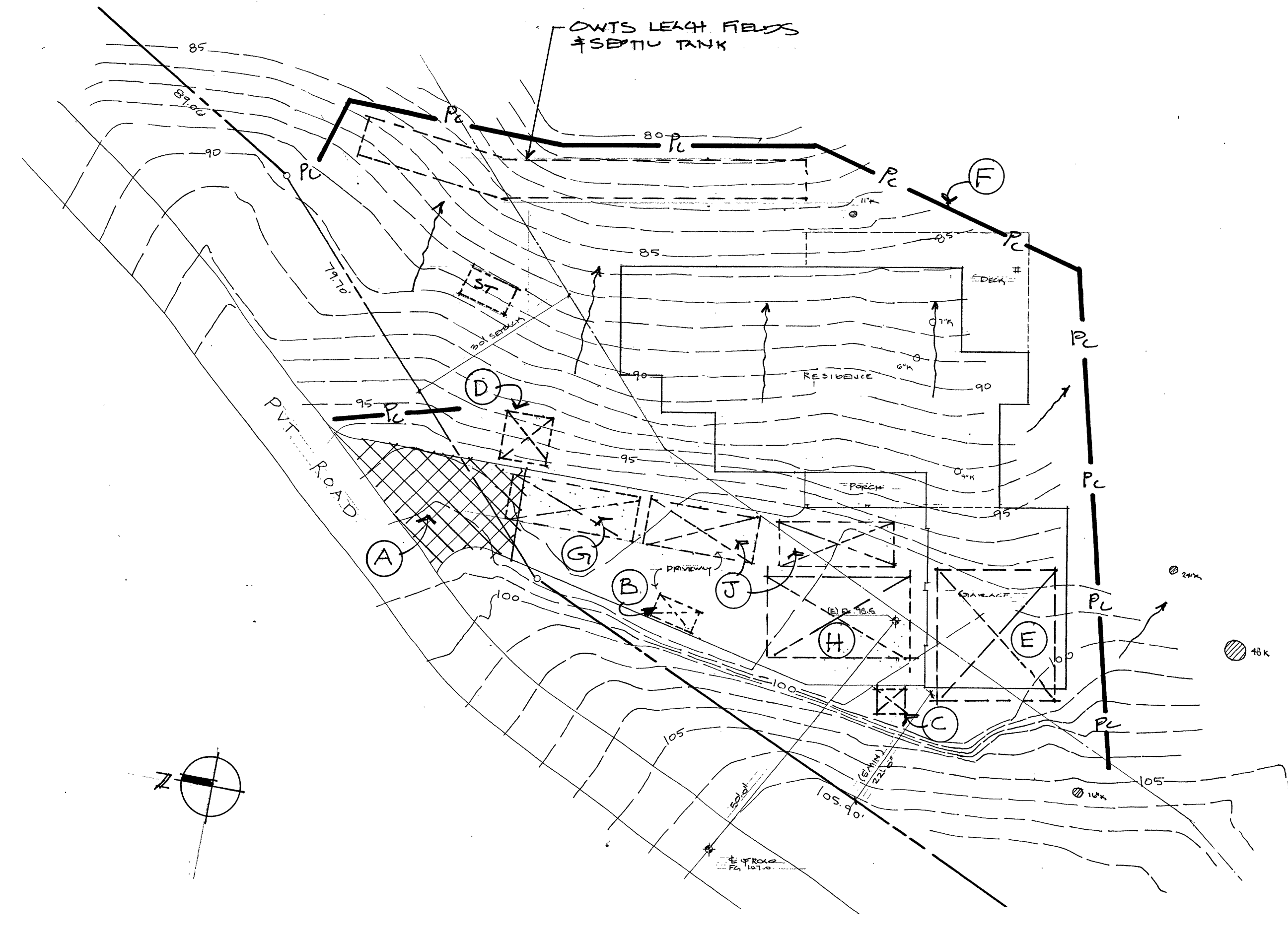

**EROSION CONTROL PLAN**

REVISIONS	BY

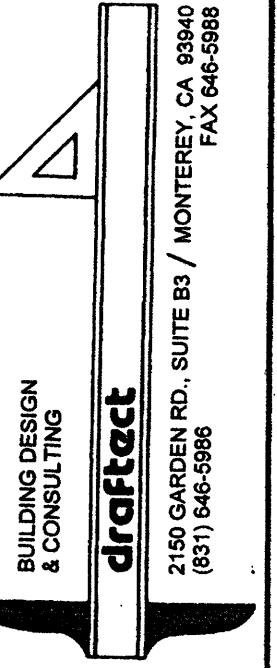

**EVERS RESIDENCE**  
**148 SAN BENANCIO ROAD**  
**SALINAS, CALIFORNIA 93908**  
**APN: 416-261-023-000 PH: 831 601-6675**

Date	11-2-25
Scale	
Drawn	
Job	33-2025
Sheet	
Of	

**Project:** Evers Residence  
148 San Benancio Road  
Salinas, CA

## Colors and Materials

**Roofing:** GAF Class "A" Comp Shingles  
Color: Barkwood



**Body:** Sherwin-Williams  
#SW704 Snowbound

SW 7004  
Snowbound

Exterior  
paint

**Trim:** Sherwin-Williams  
#SW 7041 Van Dyke Brown

SW 7041  
Van Dyke  
Brown

Exterior  
trim and  
fascia

**Siding:** Hardie Panel Board & Batt  
Ignition Resistant Fiber  
Cement Siding & Batts



**Decking & Guardrail:**  
Decking - Trex Ignition Resistant  
Redwood Color

Guard – Redwood Posts and  
Top Rail, stainless steel cables

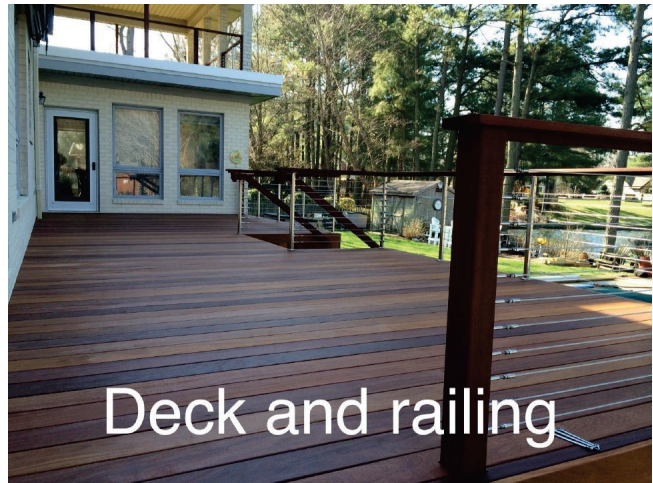

City Streets 10" Wide Sand Coal Black  
Modern LED Outdoor Wall Light



Technical Specifications

Height	7.50 inches
Width	10.00 inches
Weight	1.19 pounds
Max Wattage	8 watts
#of Bulbs	1

Dark Sky listed down light

This page intentionally left blank